



element14

---

**EN** - For pricing and availability in your local country please visit one of the below links:

**DE** - Informationen zu Preisen und Verfügbarkeit in Ihrem Land erhalten Sie über die unten aufgeführten Links:

**FR** - Pour connaître les tarifs et la disponibilité dans votre pays, cliquez sur l'un des liens suivants:

[VZA4015FAA](#)

[VZA40P2BAA](#)

[VZA40P4BAA](#)

[VZA42P2BAA](#)

[VZA44P0BAA](#)

[VZA45P5FAA](#)

[VZA47P5FAA](#)

[VZAB0P2BAA](#)

[VZAB0P4BAA](#)

[VZAB0P7BAA](#)

[VZAB2P2BAA](#)

[VZAB4P0BAA](#)

**EN**

This Datasheet is presented by  
the manufacturer

**DE**

Dieses Datenblatt wird vom  
Hersteller bereitgestellt

**FR**

Cette fiche technique est  
présentée par le fabricant

VZ

# V1000

### More performance & Quality in less space

- Current vector control
- High starting torque (200% / 0.5 Hz)
- 1:100 speed control range
- Double rating ND 120%/1min and HD 150%/1 min
- IM&PM motor control
- Online Tuning
- Low-noise Low carrier technology
- 10 years lifetime design
- Built-in filter
- Screw-less terminals
- Control Terminals with memory backup
- Fieldbus communications: Modbus, Profibus, CANopen, DeviceNet, LONworks, CompoNet, Ethernet, ML-II, PROFINET and EtherCAT
- Safety embedded: EN954-1 safety cat. 3, EN6158 SIL II and EN60204-1 Stop category 0
- CE, UL, cUL and TUV

### Ratings

- 200 V Class single-phase 0.1 to 4 kW
- 200 V Class three-phase 0.1 to 15 kW
- 400 V Class three-phase 0.2 to 15 kW



### System configuration

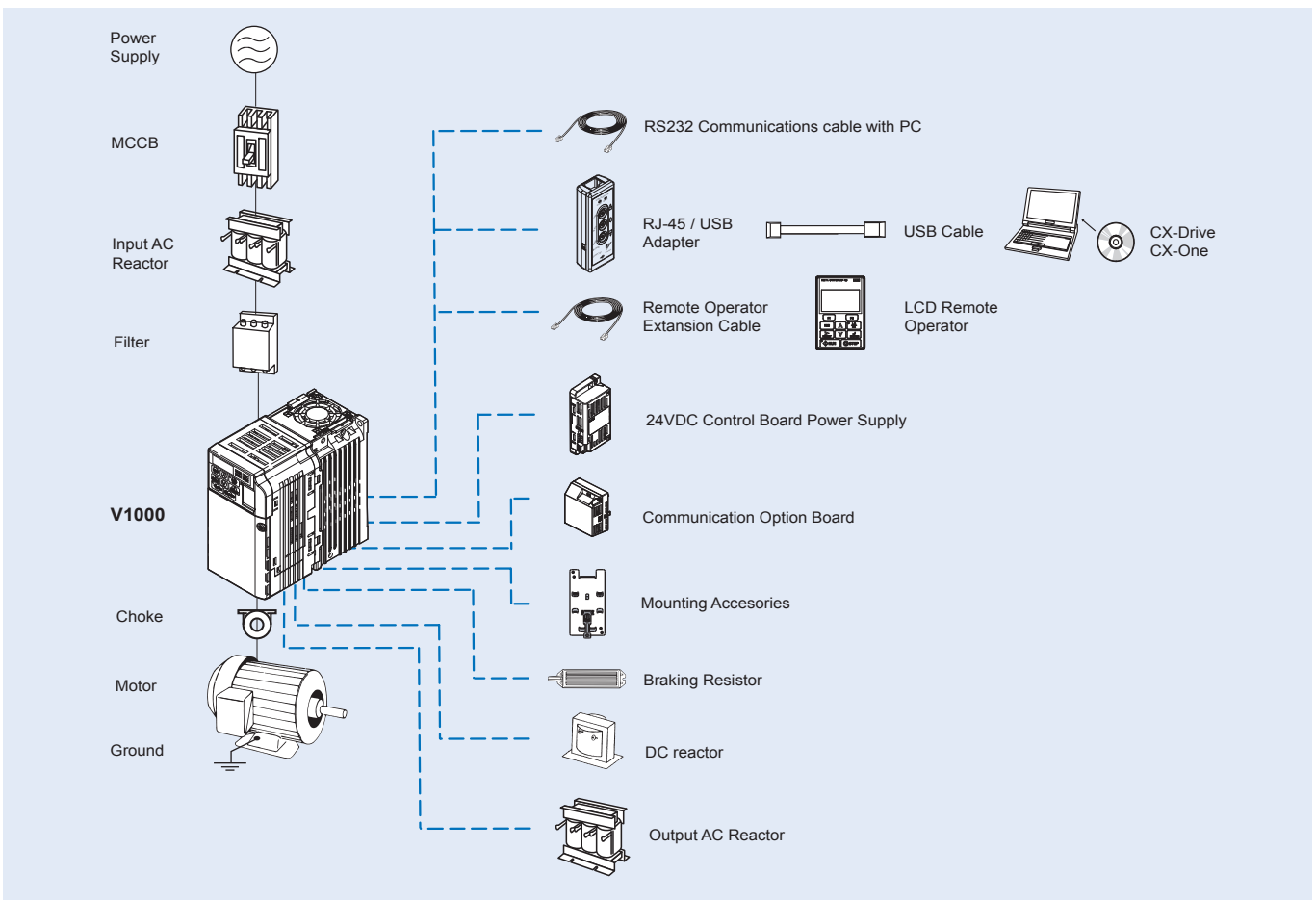

Specifications

Type designation

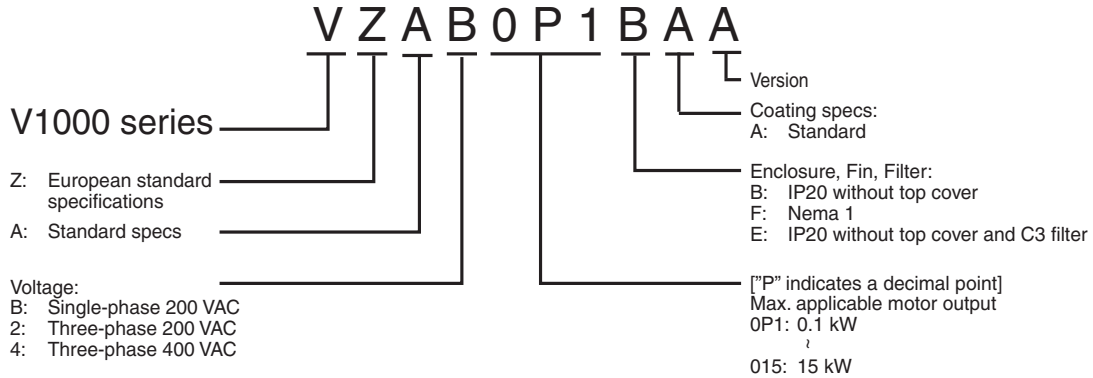

200 V class

Single-phase: VZA□		B0P1	B0P2	B0P4	B0P7	B1P5	B2P2	B4P0 <sup>1</sup>	-	-	-	-
Three-phase: VZA□		20P1	20P2	20P4	20P7	21P5	22P2	24P0	25P5	27P5	2011	2015
Motor kW <sup>2</sup>	For HD setting	0.12	0.25	0.4	1.1	1.5	2.2	4.0	5.5	7.5	11	15
	For ND setting	0.18	0.37	0.55	1.1	2.2	3.0	5.5 <sup>1</sup>	7.5	11	15	18.5
Output characteristics	Inverter capacity kVA	0.3	0.6	1.1	1.9	3.0	4.2	6.7	9.5	13	18	23
	Rated output current (A) at HD	0.8	1.6	3.0	5.0	8.0	11.0	17.5	25.0	33.0	47.0	60.0
	Rated output current (A) at ND	1.2	1.9	3.5	6.0	9.6	12.0	19.6	30.0	40.0	56.0	69.0
	Max. output voltage	Proportional to input voltage: 0..240 V										
	Max. output frequency	400 Hz										
Power supply	Rated input voltage and frequency	Single-phase 200..240 V 50/60 Hz 3-phase 200..240 V 50/60 Hz										
	Allowable voltage fluctuation	-15%..+10%										
	Allowable frequency fluctuation	+5%										

1. Only HD settings is available for this model
2. Based on a standard 4-pole motor for maximum applicable motor output:  
Heavy Duty (HD) mode with a 150% overload capacity  
Normal Duty (ND) mode with a 120% overload capacity

400 V class

Three-phase: VZA□		40P2	40P4	40P7	41P5	42P2	43P0	44P0	45P5	47P5	4011	4015
Motor kW <sup>1</sup>	For HD setting	0.37	0.55	1.10	1.5	2.2	3.0	4.0	5.5	7.5	11	15
	For ND setting	0.37	0.75	1.5	2.2	3.0	4.0	5.5	7.5	11	15	18.5
Output characteristics	Inverter capacity kVA	0.9	1.4	2.6	3.7	4.2	5.5	7.2	9.2	14.8	18	24
	Rated output current (A) at HD	1.2	1.8	3.4	4.8	5.5	7.2	9.2	14.8	18.0	24	31
	Rated output current (A) at ND	1.2	2.1	4.1	5.4	6.9	8.8	11.1	17.5	23	31	38
	Max. output voltage	0..480 V (proportional to input voltage)										
	Max. output frequency	400 Hz										
Power supply	Rated input voltage and frequency	3-phase 380..480 VAC, 50/60 Hz										
	Allowable voltage fluctuation	-15%..+10%										
	Allowable frequency fluctuation	+5%										

1. Based on a standard 4-pole motor for maximum applicable motor output:  
Heavy Duty (HD) mode with a 150% overload capacity  
Normal Duty (ND) mode with a 120% overload capacity

## Specifications

### Common specifications

Model number VZA□		Specifications
Control functions	Control methods	Sine wave PWM (V/f control, sensorless current vector control)
	Output frequency range	0.1..400 Hz
	Frequency tolerance	Digital set value: ±0.01% (-10..+50 °C)
		Analogue set value: ±0.1% (25 ±10 °C)
	Resolution of frequency set value	Digital set value: 0.01 Hz (<100 Hz), 0.1 Hz (>100 Hz)
		Analogue set value: 1/1000 of maximum frequency
	Resolution of output frequency	0.01 Hz
	Overload capability	Heavy duty use: 150% rated output current for one minute Normal duty use: 120% rated output current for one minute
	Frequency set value	0..10 V (20 kΩ), 4..20 mA (250 Ω), 0..20 mA (250 Ω) Pulse train input, frequency setting value (selectable)
	Braking torque (short term peak torque)	Short-term average deceleration torque: 150% (up 1.5 kW), 100% (for 1.5 kW), 50% (for 2.2 kW), 20% (for bigger size) Continuous regenerative torque: Approx 20% (125% with optional braking resistor, 10%ED, 10 s, braking transistor built in)
V/f Characteristics	Possible to program any V/f pattern	
Functionality	Inputs signals	Seven of the following input signals are selectable: Forward/reverse run (3-wire sequence), fault reset, external fault (NO/NC contact input), multi-step speed operation, Jog command, accel/decel time select, external baseblock, speed search command, UP/DOWN command, accel/decel hold command, LOCAL/REMOTE selection, communication/control circuit terminal selection, emergency stop fault, emergency stop alarm, self test
	Output signals	Following output signals are selectable (NO/NC contact output, 2 photo-coupler outputs): Fault, running, zero speed, speed agree, frequency detection (output frequency ≤ = ≥ set value), during overtorque detection, minor error, during baseblock, operation mode, inverter run ready, during fault retry, during undervoltage detection, reverse running, during speed search, data output through communication.
	Standard functions	Open-loop vector control, full-range automatic torque boost, slip compensation, 17-step speed operation (max.), restart after momentary power loss, DC injection braking current at stop/start (50% of inverter rated current, 0.5 sec, or less), frequency reference bias/gain, MEMOBUS communications (RS-485/422, max. 115K bps), fault retry, speed search, frequency upper/lower limit setting, overtorque detection, frequency jump, accel/decel time switch, accel/decel prohibited, S-curve accel/decel, PID control, energy-saving control, constant copy.
	Analogue inputs	2 analogue inputs, 0..10 V, 4..20 mA, 0..20 mA
	Braking/acceleration times	0.01..6000 s
	Display	Optionally frequency, current or set value Error and status LED
Protection functions	Motor overload protection	Electronic thermal overload relay
	Instantaneous overcurrent	Motor coasts to a stop at approx. 250% of inverter rated current
	Overload	Heavy Duty: Motor coasts to a stop after 1 minute at 150% of inverter rated output current Normal Duty: Motor coasts to a stop after 1 minute at 120% of inverter rated output current
	Overvoltage	Motor coasts to a stop if DC bus voltage exceed 410 V (double for 400 V class)
	Undervoltage	Stops when DC bus voltage is approx. 190 V or less (double for 400 V class) (approx. 150 V or less for single-phase series)
	Momentary power loss	Following items are selectable: not provided (stop if power loss is 15 ms or longer), continuous operation if power loss is approx. 0.5 s or shorter, continuous operation
	Cooling fin overheat	Protected by thermistor
	Stall prevention level	Stall prevention during acceleration/deceleration and constant speed operation
	Ground fault	Protected by electronic circuit (operation level is approx. 250% of rated output current)
Power charge indication	Indicates until the main circuit voltage reaches 50 V.	
Ambient conditions	Degree of protection	IP20, NEMA1
	Cooling	Cooling fan is provided for 200 V, 0.75 kW (1HP) (3/single-phase) 400 V, 1.5 kW (2HP) (3-phase), others are self-cooling
	Ambient humidity	95% RH or less (without condensation)
	Storage temperature	-20 °C..+60 °C (short-term temperature during transportation)
	Installation	Indoor (no corrosive gas, dust, etc.)
	Installation height	Max. 1000 m
Vibration	Up to 9.8 m/s <sup>2</sup> at 10 to less than 20 Hz, Up to 6.37 m/s <sup>2</sup> at 20 to 50 Hz	

Dimensions

IP20 type

Figure 1

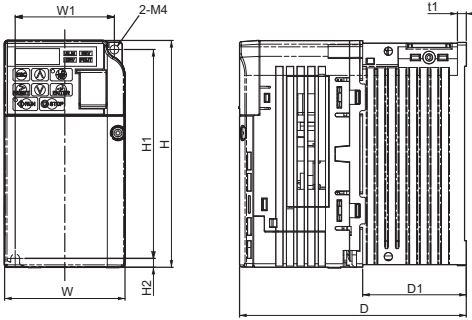
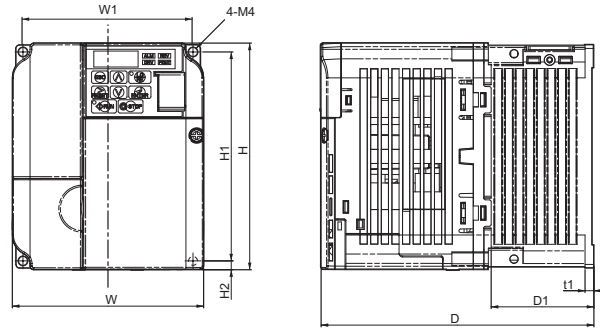
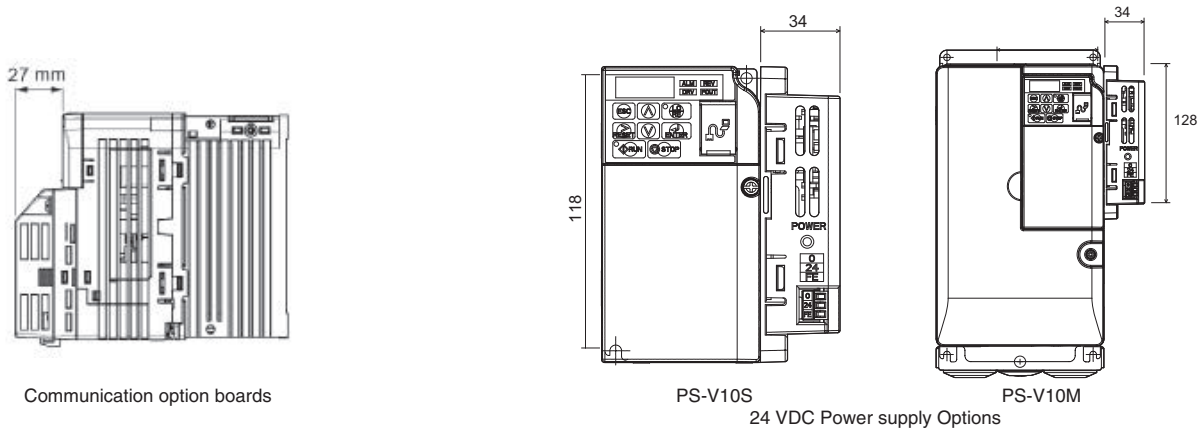

Figure 2



Voltage class	Max. applicable motor output kW	Inverter model VZA□	Figure	Dimensions in mm										Weight kg											
				W1	H1	W	H	D	t1	H2	D1	H3	H4												
Single-phase 200 V	0.12	B0P1	1	56	118	68	128	76	3	5	6.5	-	-	0.6											
	0.25	B0P2						108			38.5			0.7											
	0.55	B0P4						137.5			58			1.0											
	1.1	B0P7	2	96	108	140	154	163	180	5	65	-	-	1.7											
	1.5	B1P5												2.4											
	2.2	B2P2												3.0											
Three-phase 200 V	4.0	B4P0	1	56	118	68	128	76	3	5	6.5	-	-	0.6											
	0.12	20P1						108			38.5			0.6											
	0.25	20P2						128			58			0.9											
	0.55	20P4	2	96	108	140	129	137.5	143	5	65	-	-	1.1											
	1.1	20P7												1.3											
	1.5	21P5												1.4											
	2.2	22P2	3	128	140	254	163	187	-	6	55	13	6.2	2.1											
	4.0	24P0												3.8											
	5.5	25P5												3.8											
	7.5	27P5	3	122	248	180	290	143	-	8	75	15	7.2	5.5											
	11	2011												9.2											
	15	2015																							
Three-phase 400 V	0.37	40P2	2	96	118	108	128	81	5	5	10	-	-	0.8											
	0.55	40P4						99			28			1.0											
	1.1	40P7						137.5			58			1.4											
	1.5	41P5						154			65			1.5											
	2.2	42P2						143						1.5											
	3.0	43P0												2.1											
	4.0	44P0	3	122	248	140	254	140	-	6	55	13	6	3.8											
	5.5	45P5												6.2											
	7.5	47P5												3.8											
	11	4011												8	160	284	180	290	143	-	8	75	15	6	5.2
	15	4015																							5.5

V1000 + Option board (Communication and 24 VDC power supply)



Communication option boards

PS-V10S

24 VDC Power supply Options

PS-V10M

Built-in filter

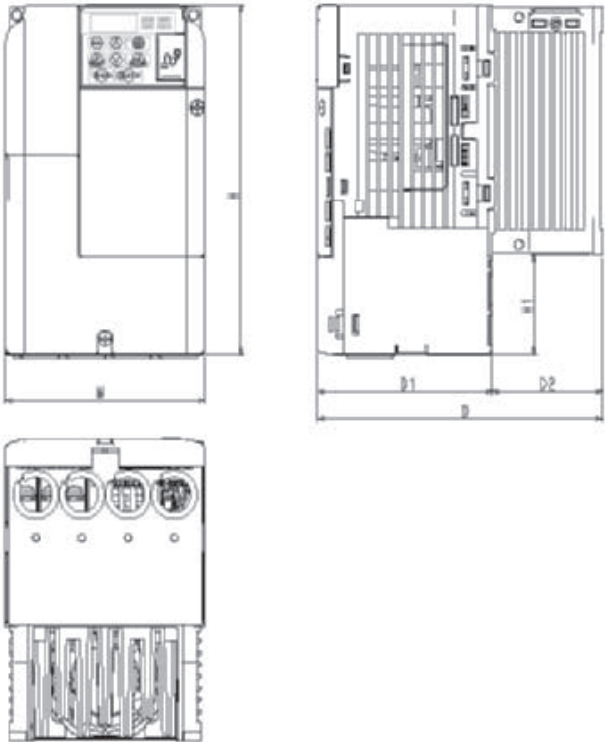

VZA□	Dimensions in mm					
	W	H	H1	D1	D2	D
B0P1	68+	178	50	69.5	6.5	76
B0P2				79.5	38.5	118
B0P4				77.9	59.6	137.5
B0P7	108			89.4	64.6	154
B1P5						
B2P2	140	183	55	96.4	66.6	163
40P2	108	178	50	69.4	11.6	81
40P4					29.6	99
40P7				77.9		137.5
41P5						
42P2				94.4	59.6	154
43P0						
44P0	140	183	55	76.4	66.6	143

Schaffner footprint filters

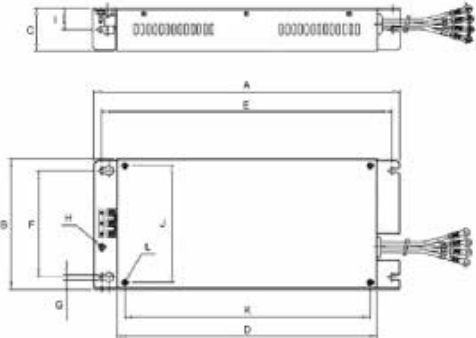

Schaffner standard model		Dimensions in mm												Weight kg
		A	B	C	D	E	F	G	H	I	J	K	L	
1x200 V	A1000-FIV1010-SE	169	71	45	135	156	51	5.3	M5	22	56	118	M4	0.44
	A1000-FIV1020-SE	169	111	50	135	156	91	5.3	M5	25	96	118	M4	0.8
	A1000-FIV1030-SE	174	144	50	135	161	120	5.3	M5	25	128	118	M4	1.2
	A1000-FIV1040-SE	174	174	50	135	161	150	5.3	M5	25	158	118	M4	1.6
3x200 V	A1000-FIV2010-SE	194	82	40	135	181	62	5.5	M5	20.5	56	118	M4	0.4
	A1000-FIV2020-SE	169	111	45	135	156	91	5.3	M5	22	96	118	M4	0.58
	A1000-FIV2030-SE	174	144	50	135	161	120	5.3	M5	25	128	118	M4	0.9
	A1000-FIV2060-SE	305	144	56	264	289	122	6.5	M5	28	122	248	M5	2.0
	A1000-FIV2080-SE	345	182	65	300	325	160	6.5	M6	32.5	160	285	M5	2.6
3x400 V	A1000-FIV2100-SE	394	214	65	353	378	192	6.5	M8	32.5	192	336	M6	3.1
	A1000-FIV3005-SE	169	111	45	135	156	91	5.3	M5	22	96	118	M4	0.5
	A1000-FIV3010-SE	169	111	45	135	156	91	5.3	M5	22	96	118	M4	0.7
	A1000-FIV3020-SE	174	144	50	135	161	120	5.3	M5	25	128	118	M4	0.9
	A1000-FIV3030-SE	305	144	56	264	289	122	6.5	M5	28	122	248	M5	1.8
A1000-FIV3050-SE	341	182	65	300	325	160	6.5	M6	32.5	160	285	M5	2.7	

Schaffner low leakage model		Dimensions in mm												Weight kg
		A	B	C	D	E	F	G	H	I	J	K	L	
1x200 V	A1000-FIV1010-SE-LL	166	70	40	130	156	51	5.3	M5	20	56	118	M4	0.33
	A1000-FIV1020-SE-LL	166	110	50	130	156	91	5.3	M5	25	96	118	M4	0.72
	A1000-FIV1030-SE-LL	170	142	50	130	161	120	5.3	M5	25	128	118	M4	0.92
	A1000-FIV1040-SE-LL	173	176	50	135	161	150	5.3	M5	25	158	118	M4	1.4
3x200 V	A1000-FIV2010-SE-LL	191	80	40	130	181	62	5.3	M5	20	56	118	M4	0.35
	A1000-FIV2020-SE-LL	166	110	50	130	156	91	5.3	M5	25	96	118	M4	0.65
	A1000-FIV2030-SE-LL	172	142	50	130	161	120	5.3	M5	25	128	118	M4	0.92
3x400 V	A1000-FIV3005-SE-LL	166	110	45	130	156	91	5.3	M5	22.5	96	118	M4	0.5
	A1000-FIV3010-SE-LL	166	110	45	130	156	91	5.3	M5	22.5	96	118	M4	0.66
	A1000-FIV3020-SE-LL	171	142	45	130	161	120	5.3	M5	22.5	128	118	M4	0.85
	A1000-FIV3030-SE-LL	304	140	55	263	290	122	6.5	M5	27.5	122	248	M5	1.85
	A1000-FIV3050-SE-LL	344	180	55	300	330	160	6.5	M6	27.5	160	285	M5	2.65

Rasmi footprint filters

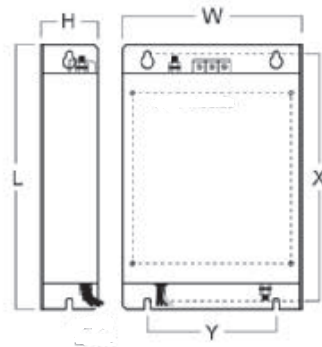

Rasmi standard and low leakage model		Dimensions in mm						Weight kg
		W	H	L	X	Y	M	
1x200 V	A1000-FIV1010-RE□	71	45	169	156	51	M4	0.6
	A1000-FIV1020-RE□	111	50	169	156	91	M4	1.0
	A1000-FIV1030-RE□	144	50	174	161	120	M4	1.2
	A1000-FIV1040-RE□	174	50	174	161	150	M4	1.5
3x200 V	A1000-FIV2010-RE□	82	50	194	181	62	M4	1.0
	A1000-FIV2020-RE□	111	50	169	156	91	M4	1.1
	A1000-FIV2030-RE□	144	50	174	161	120	M4	1.2
	A1000-FIV2060-RE□	150	52	320	290	122	M5	2.8
	A1000-FIV2080-RE□	188	62	362	330	160	M5	4.5
	A1000-FIV2100-RE□	220	62	415	380	192	M6	4.5
3x400 V	A1000-FIV3005-RE□	111	45	169	156	91	M4	1.0
	A1000-FIV3010-RE□	111	45	169	156	91	M4	1.0
	A1000-FIV3020-RE□	144	50	174	161	120	M4	1.7
	A1000-FIV3030-RE□	150	52	306	290	122	M5	2.0
	A1000-FIV3050-RE□	182	62	357	330	160	M5	2.8

Remote LCD operator

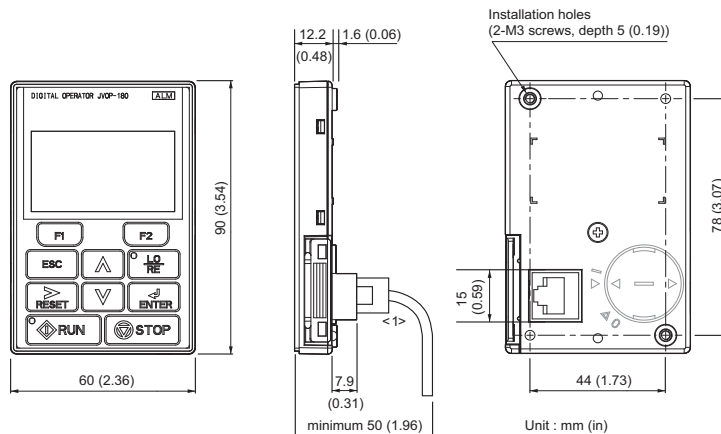

Input AC Reactor

Single-phase

Voltage	Reference	Dimensions								Weight kg
		A	B	C	D	E	F	G	H	
200 V	AX-RAI02000070-DE	84	113	96	101	66	5	7.5	2	1.22
	AX-RAI01700140-DE	84	113	116	101	66	5	7.5	2	1.95
	AX-RAI01200200-DE	84	113	131	101	66	5	7.5	2	2.55
	AX-RAI00630240-DE	84	113	116	101	66	5	7.5	2	1.95

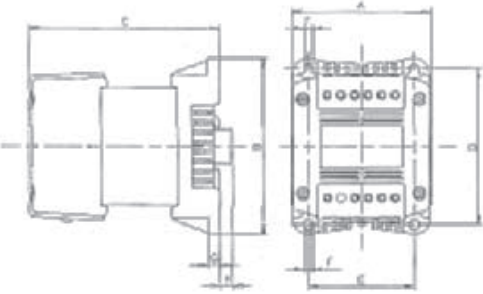

Three-phase

Voltage	Reference	Dimensions						Weight kg
		A	B2	C2	D	E	F	
200 V	AX-RAI02800080-DE	120	70	120	80	52	5.5	1.78
	AX-RAI00880200-DE	120	80	120	80	62	5.5	2.35
	AX-RAI00350335-DE	180	85	190	140	55	6	5.5
	AX-RAI00180670-DE	180	85	190	140	55	6	5.5
400 V	AX-RAI07700050-DE	120	70	120	80	52	5.5	1.78
	AX-RAI03500100-DE	120	80	120	80	62	5.5	2.35
	AX-RAI01300170-DE	120	80	120	80	62	5.5	2.50
	AX-RAI00740335-DE	180	85	190	140	55	6	5.5

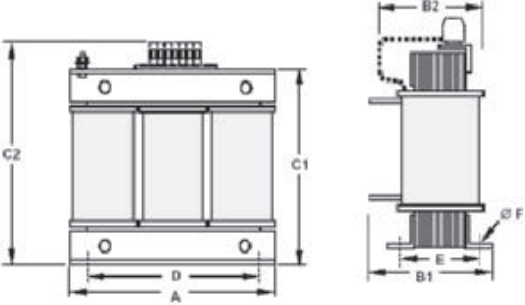

DC Reactor

Voltage	Reference	Dimensions								Weight kg	
		A	B	C	D	E	F	G	H		
200 V	AX-RC21400016-DE	84	113	96	101	66	5	7.5	2	1.22	
	AX-RC10700032-DE			105							1.60
	AX-RC06750061-DE			116							1.95
	AX-RC03510093-DE			116							1.95
	AX-RC01600223-DE	108	135	124	120	82	6.5	9.5	9.5	3.20	
	AX-RC01110309-DE	120	152	136	135	94	7			5.20	
	AX-RC00840437-DE			146				6.00			
	AX-RC00590614-DE	150	177	160	160	115	7	2	11.4		
	AX-RC00440859-DE			182.6					14.3		
400 V	AX-RC43000020-DE	84	113	96	101	66	5	7.5	2	1.22	
	AX-RC27000030-DE			105							1.60
	AX-RC14000047-DE			116							1.95
	AX-RC10100069-DE			131							2.65
	AX-RC08250093-DE	108	135	133	120	82	6.5	9.5	9.5	3.70	
	AX-RC06400116-DE	120	152	136	135	94	7			5.20	
	AX-RC04410167-DE			146				6.00			
	AX-RC03350219-DE	150	177	160	160	115	7	2	11.4		
	AX-RC02330307-DE			182.6					14.3		
	AX-RC01750430-DE			182.6					14.3		

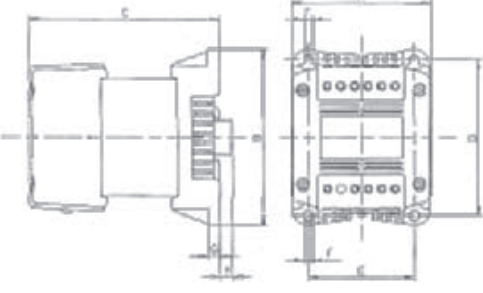



## Output AC Reactor

Voltage	Reference	Dimensions						Weight kg
		A	B2	C2	D	E	F	
200 V	AX-RAO11500026-DE	120	70	120	80	52	5.5	1.78
	AX-RAO07600042-DE	120	70	120	80	52	5.5	1.78
	AX-RAO04100075-DE	120	80	120	80	62	5.5	2.35
	AX-RAO03000105-DE	120	80	120	80	62	5.5	2.35
	AX-RAO01830180-DE	180	85	190	140	55	6	5.5
	AX-RAO01150220-DE	180	85	190	140	55	6	5.5
	AX-RAO00950320-DE	180	85	205	140	55	6	6.5
	AX-RAO00630430-DE	180	95	205	140	65	6	9.1
	AX-RAO00490640-DE	180	95	205	140	65	6	9.1
400 V	AX-RAO16300038-DE	120	70	120	80	52	5.5	1.78
	AX-RAO11800053-DE	120	80	120	80	52	5.5	2.35
	AX-RAO07300080-DE	120	80	120	80	62	5.5	2.35
	AX-RAO04600110-DE	180	85	190	140	55	6	5.5
	AX-RAO03600160-DE	180	85	205	140	55	6	6.5
	AX-RAO02500220-DE	180	95	205	140	55	6	9.1
	AX-RAO02000320-DE	180	105	205	140	85	6	11.7

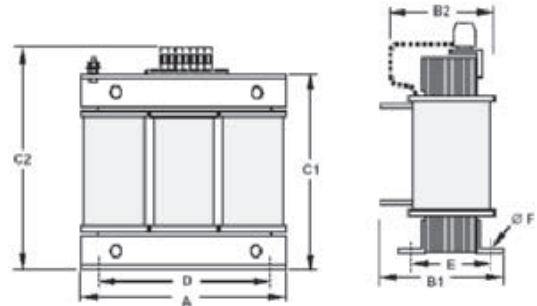

## Chokes

Description	D diameter	Motor KW	Dimensions in mm						Weight kg
			L	W	H	X	Y	m	
AX-FER2102-RE	21	< 2.2	85	22	46	70	-	5	0.1
AX-FER2515-RE	25	< 15	105	25	62	90	-	5	0.2
AX-FER5045-RE	50	< 45	150	50	110	125	30	5	0.7

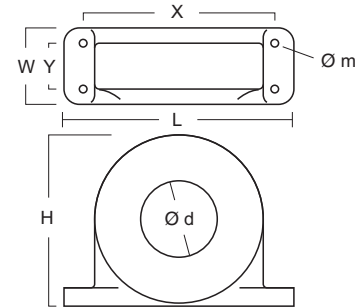

## Resistor Dimensions

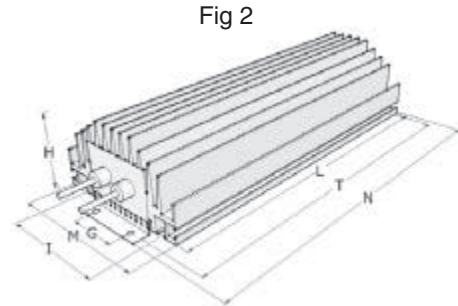
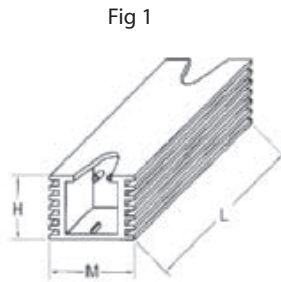
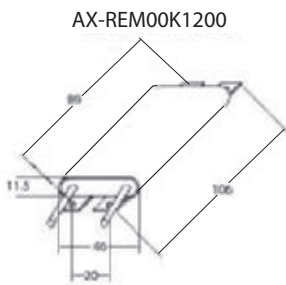

Type	Fig.	Dimensions in mm							Weight kg
		L	H	M	I	T	G	N	
AX-REM00K1400-IE	1	105	27	36	94	-	-	-	0.2
AX-REM00K2070-IE									
AX-REM00K2120-IE									
AX-REM00K2200-IE									
AX-REM00K4035-IE	2	200	61	100	74	211	40	230	0.425
AX-REM00K6035-IE									0.73
AX-REM00K9020-IE									1.41
AX-REM00K9017-IE									

DIN rail mounting bracket

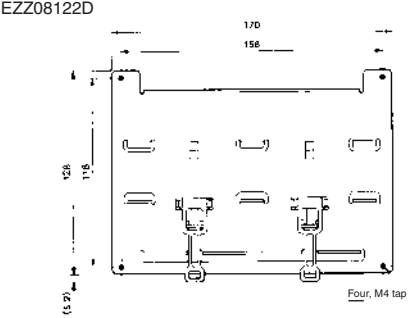
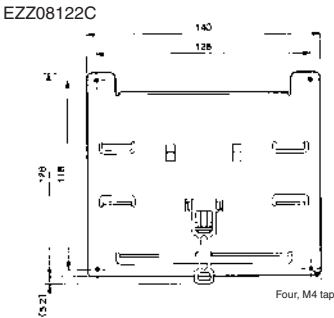
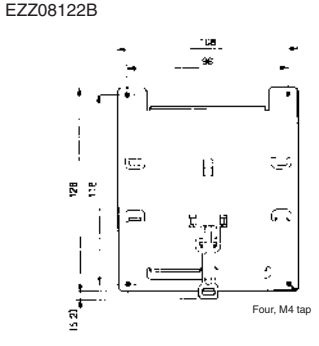
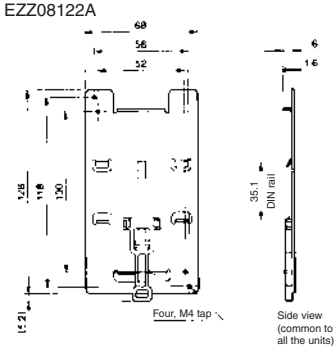

Inverter VZA□		DIN rail mounting bracket
1-phase 200 VAC	B0P1/ B0P2/ B0P4	EZZ08122A
	B0P7/ B1P5	EZZ08122B
	B2P2	EZZ08122C
	B4P0	EZZ08122D
3-phase 200 VAC	20P1/ 20P2 / 20P4/ 20P7	EZZ08122A
	21P5/ 22P2	EZZ08122B
	24P0	EZZ08122C
3-phase 400 VAC	40P2/ 40P4/ 40P7/ 41P5/ 42P2	EZZ08122B
	44P0	EZZ08122C

Heatsink attachment and Panel cut dimensions

Heatsink External Mounting Attachment

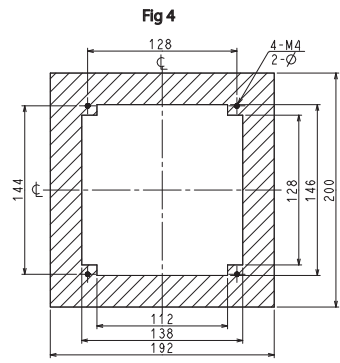
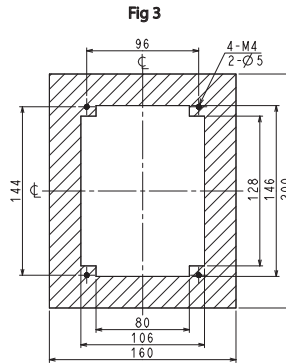
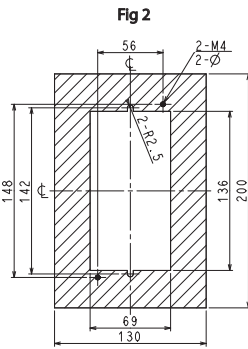
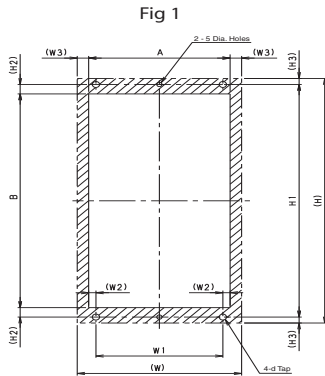
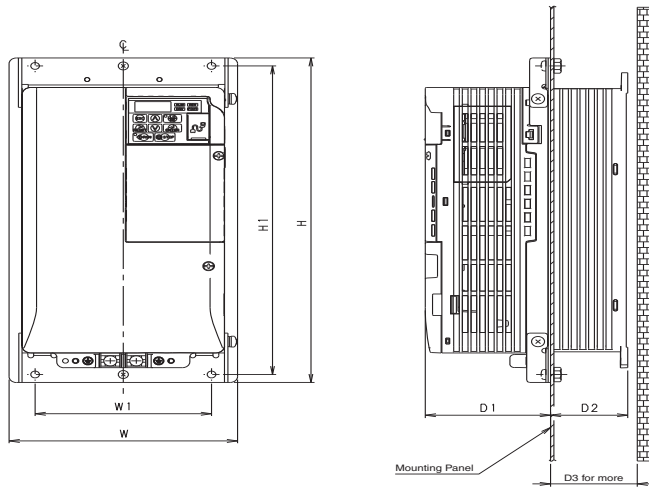

VZA□	Reference	Frame							Panel Cutting												
		W	H	W1	H1	D1	D2	D3	Fig	(W2)	(W3)	(H2)	(H3)	A	B						
1X200 V	B0P1	100-034-075	68	128	56	118	69.2	12	30	2											
	B0P2																				
	B0P4						79.2	42	50												
	B0P7	100-034-076	108	128	96	118	79.5	58	70	3											
	B1P5	100-034-079					96														
	B2P2	100-034-080					98	65													
B4P0	100-036-357	170		158		115			4												
3x200 V	20P1	100-034-075	68	128	56	118	69.2	12	30						2						
	20P2																				
	20P4							42	50												
	20P7	100-034-077	108	128	96	118	71	58	70	3											
	21P5	79.5																			
	22P2	100-034-079					86.5	53.5	60												
	24P0	100-034-080	140		128					4											
	25P5	100-036-300	158	286	122	272	86.6	53.4	60	1						9	9	8.5	7	140	255
	27P5															10		10.5		180	287
	2011										100-036-301	198	322	160	308	89.6	73.4	80	14	10.5	10.5
2015	100-036-302	241	380	192	362	110.6	76.4	85													
3X400 V	40P2	100-034-078	108	128	96	118	71	13.2	30							3					
	40P4																				
	40P7						79.5	28	40												
	41P5	100-034-079	108	128	96	118	96	58	70	4											
	42P2																				
	43P0																				
	44P0	100-034-080	140		128		78	65		4											
	45P5	100-036-300	158	286	122	272	86.6	53.4	60	1						9		8.5		140	255
	47P5															10	9	10.5	7	180	287
	4011										198	322	160	308	73.4	80					
4015	100-036-301																				

Installation

Standard connections

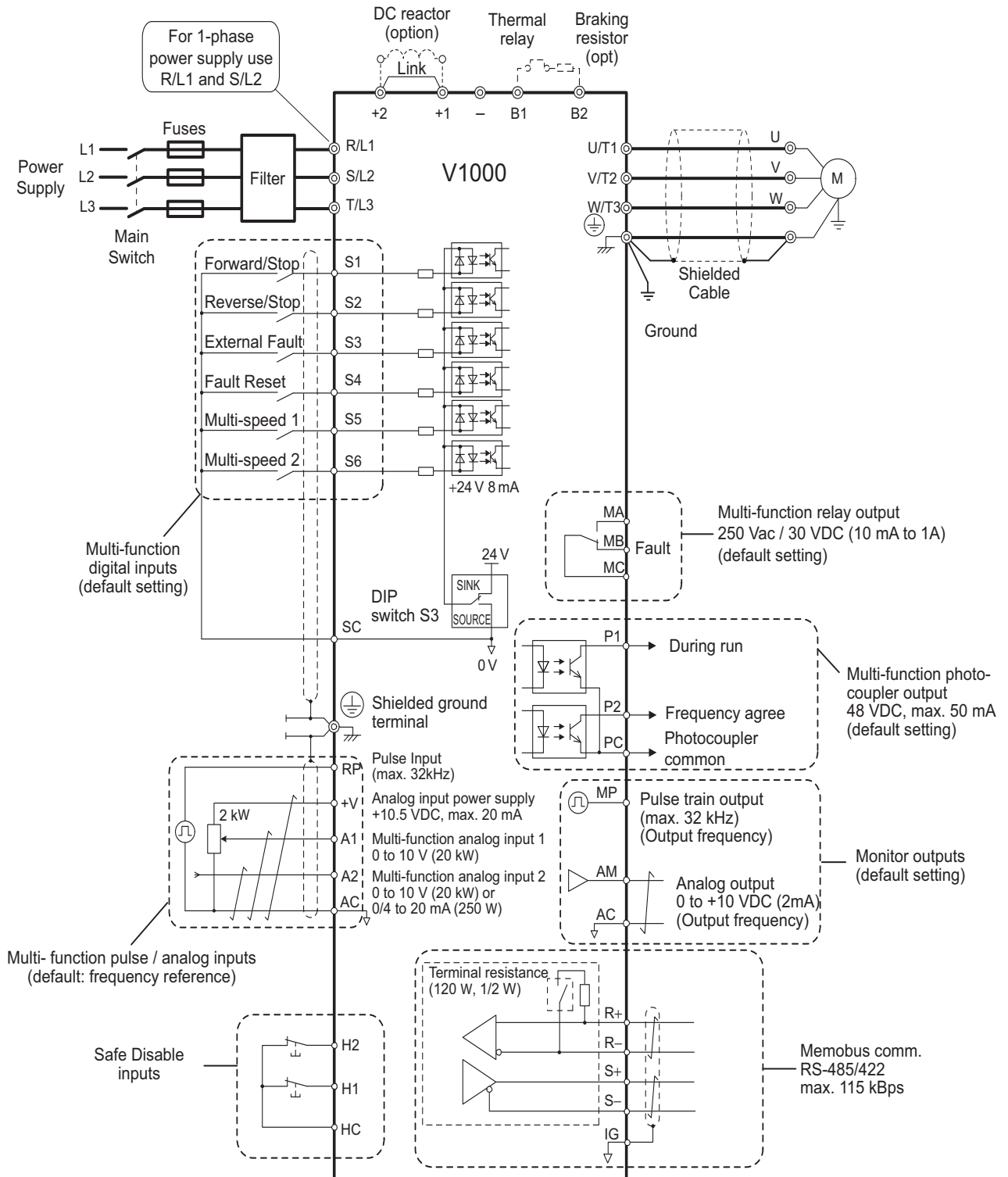

Symbols:

- ⊗ Use twisted pair cables
- ⊗ Indicates a main circuit terminal
- ⊗ Use shielded twisted pair cables
- Indicates a control circuit terminal.

Main circuit

Terminal	Name	Function (signal level)
R/L1, S/L2, T/L3	Main circuit power supply input	Used to connect line power to the drive. Drives with single-phase 200 V input power use only terminals R/L1 and S/L2 (T/L3 is not connected to anything)
U/T1, V/T2, W/T3	Inverter output	Used to connect the motor
B1, B2	Braking resistor connection	Available for connecting a braking resistor or the braking resistor unit option.
+2, +1	DC reactor connection	Remove the short bar between +2 and +1 when connecting DC reactor (option)
+1, -	DC power supply input	For power supply input (+1: positive electrode; - : negative electrode)
⊕	Grounding	For grounding (grounding should conform to the local grounding code.)

Control Circuit

Type	No.	Signal name	Function	Signal level
Digital input signals	S1	Multi-function input selection 1	Factory setting: runs when CLOSED, stops when OPEN.	24 VDC, 8 mA photocoupler insulation
	S2	Multi-function input selection 2	Factory setting: runs when CLOSED, stops when OPEN.	
	S3	Multi-function input selection 3	Factory setting: External Fault (N.O.)	
	S4	Multi-function input selection 4	Factory setting: Fault reset	
	S5	Multi-function input selection 5	Factory setting: Multi-step speed cmd 1	
	S6	Multi-function input selection 6	Factory setting: Multi-step speed cmd 2	
	SC	Multi-function input selection Common	Common for control signal	
Analog input signals	RP	Main Speed Cmd Pulse Train Input	32 kHz max.	
	FS	Power Supply for Frequency Setting	+10 V (allowable max current 20 mA)	
	FR1	Main Speed Freq Ref	Voltage input or current input 0 to +10 VDC (20 kΩ) (resolution 1/1000)	
	FR2		4 to 20 mA (250 Ω) or 0 to 20 mA (250 Ω) Resolution: 1/500	
	FC	Frequency reference common	0 V	
Fast Stop Cmd	HC	Power Supply Fast Stop Cmd	+24 V (max allowable current 10 mA)	
	H1	Special Digital input	Open: Fast Stop Closed: Normal Operation	
	H2	Special Digital input		
Digital output signals	MA	NO contact output	Factory setting: "fault"	Contact capacity 250 VAC, 1 A or less 30 VDC, 1 A or less
	MB	NC Output		
	MC	Relay Output common		
	P1	Photocoupler output 1	Factory setting: During run	Photocoupler output: +48 VDC, 50 mA or less
	P2	Photocoupler output 2	Factory setting: Frequency Agree	
	PC	Photocoupler output common	0 V	
Analog output signals	PM	Pulse train Output	max 33 kHz	
	AM	Analog monitor output	Factory setting: "output frequency" 0 to +10 V output Resolution: 1/1000	0 to 10 V 2 mA or less Resolution: 8 bits
	AC	Analog monitor common	0 V	
RS-485/422	R+	Communication input (+)	For MEMOBUS communication operation by RS-485 or RS-422 communication is available.	RS-485/422 MEMOBUS protocol
	R-	Communication input (-)		
	S+	Communication output (+)		
	S-	Communication output (-)		

a: Space required differs by model:  
Up to 3.7 kW: minimum 30 mm  
5.5 kW and above: minimum 50 mm

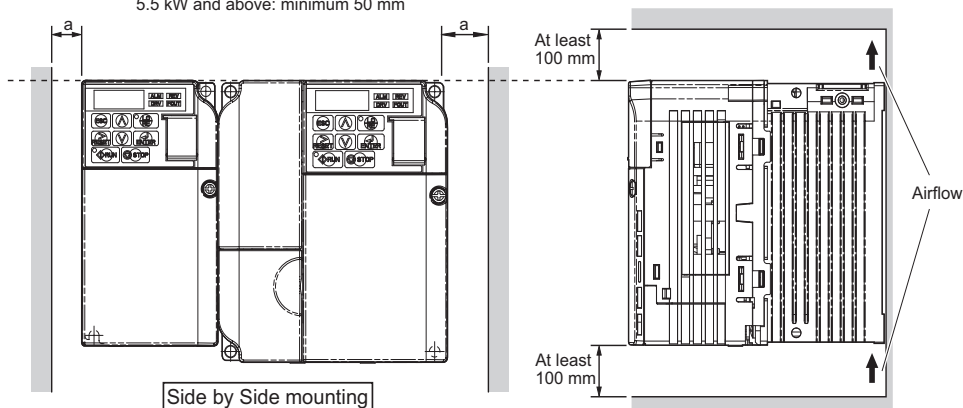

**Inverter heat loss**

**Single-phase 200 V class**

Model VZA		B0P1	B0P2	B0P4	B0P7	B1P5	B2P2	B4P0	
Inverter capacity kVA		0.3	0.6	1.1	1.9	3.0	4.2	6.7	
Rated current (A) at HD		0.8	1.6	3	5	8	11	17.5	
Rated current (A) at ND		1.2	1.9	3.5	6.0	9.6	12.0	-	
Heat loss W HD	Fin	4.3	7.9	16.1	42.5	54.8	70.7	110.5	
	Inside unit	7.4	8.9	11.5	19.0	25.9	34.1	51.4	
	Total heat loss	11.7	16.7	27.7	61.5	80.7	104.8	161.9	
Heat loss W ND	Fin	4.7	7.2	15.1	26.2	48.6	57.9	93.3	
	Inside unit	8.4	9.6	14.3	20.8	29.0	36.3	58.5	
	Total heat loss	13.1	16.8	28.3	56.5	77.6	94.2	151.8	
Cooling Method		Self Cooled				Fan Cooled			

**Three-phase 200 V class**

Model VZA		20P1	20P2	20P4	20P7	21P5	22P2	24P0	25P5	27P5	2011	2015	
Inverter capacity kVA		0.3	0.6	1.1	1.9	3.0	4.2	6.7	9.5	13	18	23	
Rated current (A) at HD		0.8	1.6	3	5	8	11	17.5	25	33	47.0	60.0	
Rated current (A) at ND		1.2	1.9	3.5	6.0	9.6	12.0	19.6	30.0	40.0	56.0	69.0	
Heat loss W HD	Fin	4.3	7.9	16.1	27.4	54.8	70.7	110.5	231.5	239.5	347.6	437.7	
	Inside unit	7.3	8.8	11.5	15.9	23.8	30.0	43.3	72.2	81.8	117.6	151.4	
	Total heat loss	11.6	16.7	27.7	43.3	78.6	100.6	153.8	303.7	321.3	465.2	589.1	
Heat loss W ND	Fin	4.7	7.2	14.0	35.6	48.6	57.9	93.3	236.8	258.8	342.8	448.5	
	Inside unit	7.9	9.4	13.4	16.9	25.0	29.6	45.0	87.2	11.4	149.1	182.2	
	Total heat loss	12.6	16.6	28.5	43.1	73.6	87.5	138.2	324.0	370.3	491.9	630.7	
Cooling Method		Self Cooled				Fan Cooled							

**Three-phase 400 V class**

Model VZA		40P2	40P4	40P7	41P5	42P2	43P0	44P0	45P5	47P5	4011	4015	
Inverter capacity kVA		0.9	1.4	2.6	3.7	4.2	5.5	7.2	9.2	14.8	18	24	
Rated current (A) at HD		1.2	1.8	3.4	4.8	5.5	7.2	9.2	14.8	18.0	24	31	
Rated current (A) at ND		1.2	2.1	4.1	5.4	6.9	8.8	11.1	17.5	23	31	38	
Heat loss W HD	Fin	19.2	28.9	42.3	70.7	81.0	84.6	107.2	166.0	207.1	266.9	319.1	
	Inside unit	11.4	14.9	17.9	26.2	30.7	32.9	41.5	62.7	78.1	105.9	126.6	
	Total heat loss	30.6	43.7	60.2	96.9	111.7	117.5	148.7	228.7	285.2	372.7	445.8	
Heat loss W ND	Fin	8.2	15.5	26.4	37.5	49.7	55.7	71.9	170.3	199.5	268.6	298.7	
	Inside unit	9.2	13.1	15.8	20.0	26.3	29.4	43.6	78.1	105.3	142.8	152.2	
	Total heat loss	17.4	28.6	42.2	57.5	76.0	85.1	115.5	248.4	304.8	411.4	450.9	
Cooling Method		Self Cooled				Fan Cooled							

## Connections for braking resistor

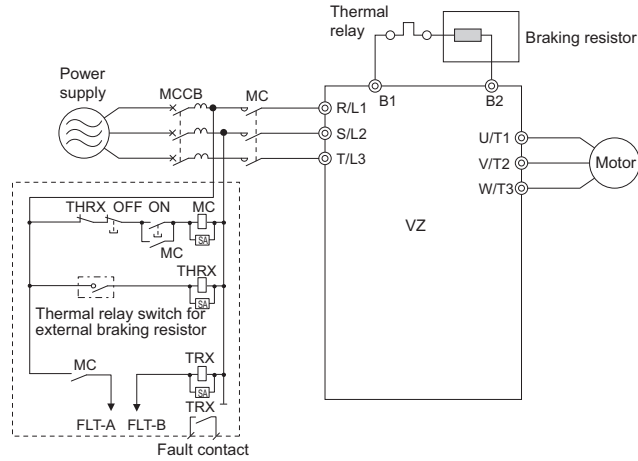

## Input AC Reactor

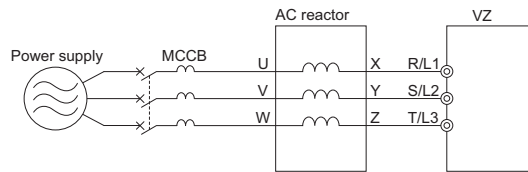

1 phase 200 V class				3 phase 200 V class				400 V class			
Max. applicable motor output kW	Reference	Current value A	Inductance mH	Max. applicable motor output kW	Reference	Current value A	Inductance mH	Max. applicable motor output kW	Reference	Current value A	Inductance mH
0.4	AX-RAI02000070-DE	7.0	2.0	1.5	AX-RAI02800080-DE	8.0	2.8	1.5	AX-RAI07700050-DE	5.0	7.7
0.75	AX-RAI01700140-DE	14.0	1.7	3.7	AX-RAI00880200-DE	20.0	0.88	4.0	AX-RAI03500100-DE	10.0	3.5
1.5	AX-RAI01200200-DE	20.0	1.2	7.5	AX-RAI00350335-DE	33.5	0.35	7.5	AX-RAI01300170-DE	17.0	1.3
2.2	AX-RAI00630240-DE	24.0	0.63	11	AX-RAI00180670-DE	67.0	0.18	11	AX-RAI00740335-DE	33.5	0.74
-	-	-	-	15	AX-RAI00091000-DE	100.0	0.09	15	AX-RAI00360500-DE	50.0	0.36

## DC Reactor

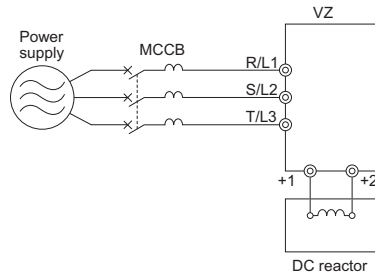

200 V class				400 V class			
Max. applicable motor output kW	Reference	Current value A	Inductance mH	Max. applicable motor output kW	Reference	Current value A	Inductance mH
0.2	AX-RC21400016-DE	1.6	21.4	0.4	AX-RC43000020-DE	2.0	43.0
0.4	AX-RC10700032-DE	3.2	10.7	0.7	AX-RC27000030-DE	3.0	27.0
0.7	AX-RC06750061-DE	6.1	6.75	1.5	AX-RC14000047-DE	4.7	14.0
1.5	AX-RC03510093-DE	9.3	3.51	2.2	AX-RC10100069-DE	6.9	10.1
2.2	AX-RC02510138-DE	13.8	2.51	3.0	AX-RC08250093-DE	9.3	8.25
3.7	AX-RC01600223-DE	22.3	1.60	4.0	AX-RC06400116-DE	11.6	6.40
5.5	AX-RC01110309-DE	30.9	1.11	5.5	AX-RC04410167-DE	16.7	4.41
7.5	AX-RC00840437-DE	43.7	0.84	7.5	AX-RC03350219-DE	21.9	3.35
11.0	AX-RC00590614-DE	61.4	0.59	11.0	AX-RC02330307-DE	30.7	2.33
15.0	AX-RC00440859-DE	85.9	0.44	15.0	AX-RC01750430-DE	43.0	1.75

## Output AC Reactor

200 V class				400 V class			
Max. applicable motor output kW	Reference	Current value A	Inductance mH	Max. applicable motor output kW	Reference	Current value A	Inductance mH
0.4	AX-RAO11500026-DE	2.6	11.50	1.5	AX-RAO16300038-DE	3.8	16.30
0.75	AX-RAO07600042-DE	4.2	7.60				
1.5	AX-RAO04100075-DE	7.5	4.10				
2.2	AX-RAO03000105-DE	10.5	3.00	2.2	AX-RAO11800053-DE	5.3	11.80
3.7	AX-RAO01830160-DE	16.0	1.83	4.0	AX-RAO07300080-DE	8.0	7.30
5.5	AX-RAO01150220-DE	22.0	1.15	5.5	AX-RAO04600110-DE	11.0	4.60
7.5	AX-RAO00950320-DE	32.0	0.95	7.5	AX-RAO03600160-DE	16.0	3.60
11	AX-RAO00630430-DE	43.0	0.63	11	AX-RAO02500220-DE	22.0	2.50
15	AX-RAO00490640-DE	64.0	0.49	15	AX-RAO02000320-DE	32.0	2.00

Safety System

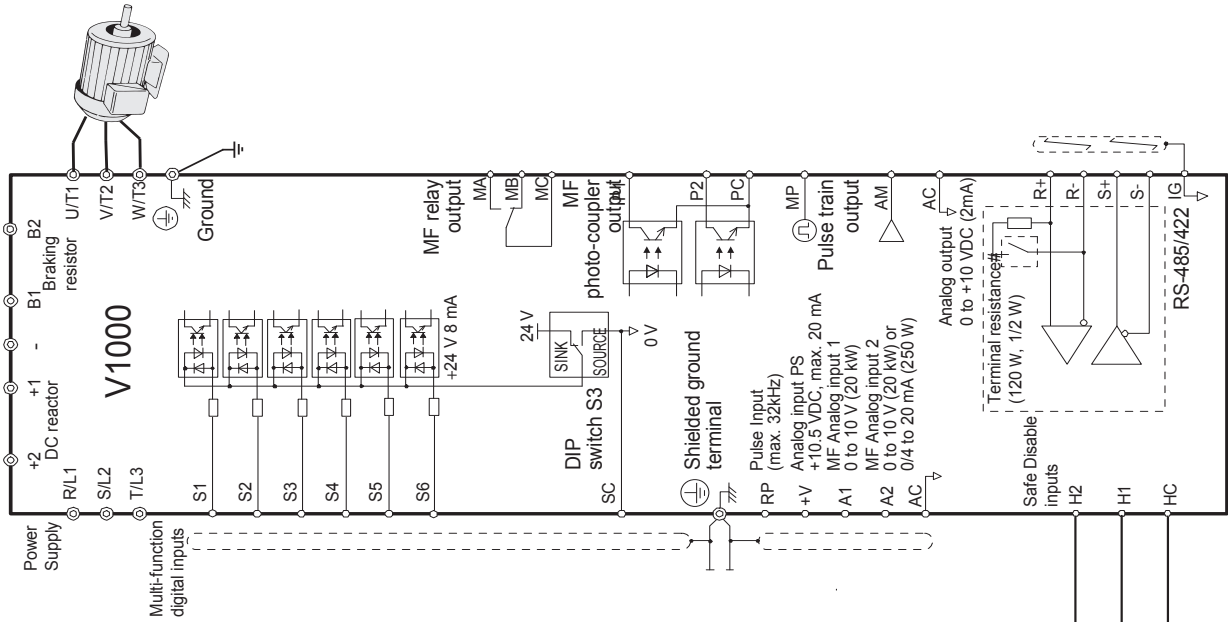

V1000 safe stop application using OMRON G9SB safety relay unit complies to safety category 3 according EN 954-1 / Stop category 0 according EN60204  
 Ensure V1000 and safety relay are mounted in the same cabinet to exclude cross circuit between H1 and H2

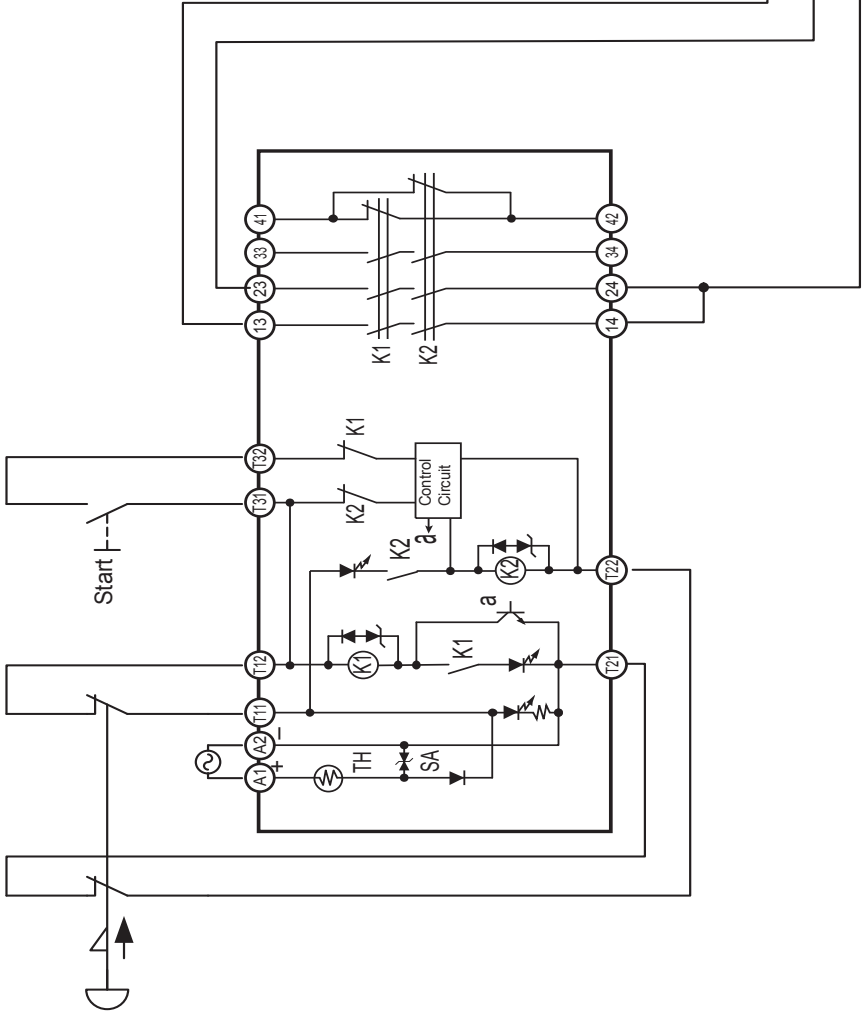



Ordering information

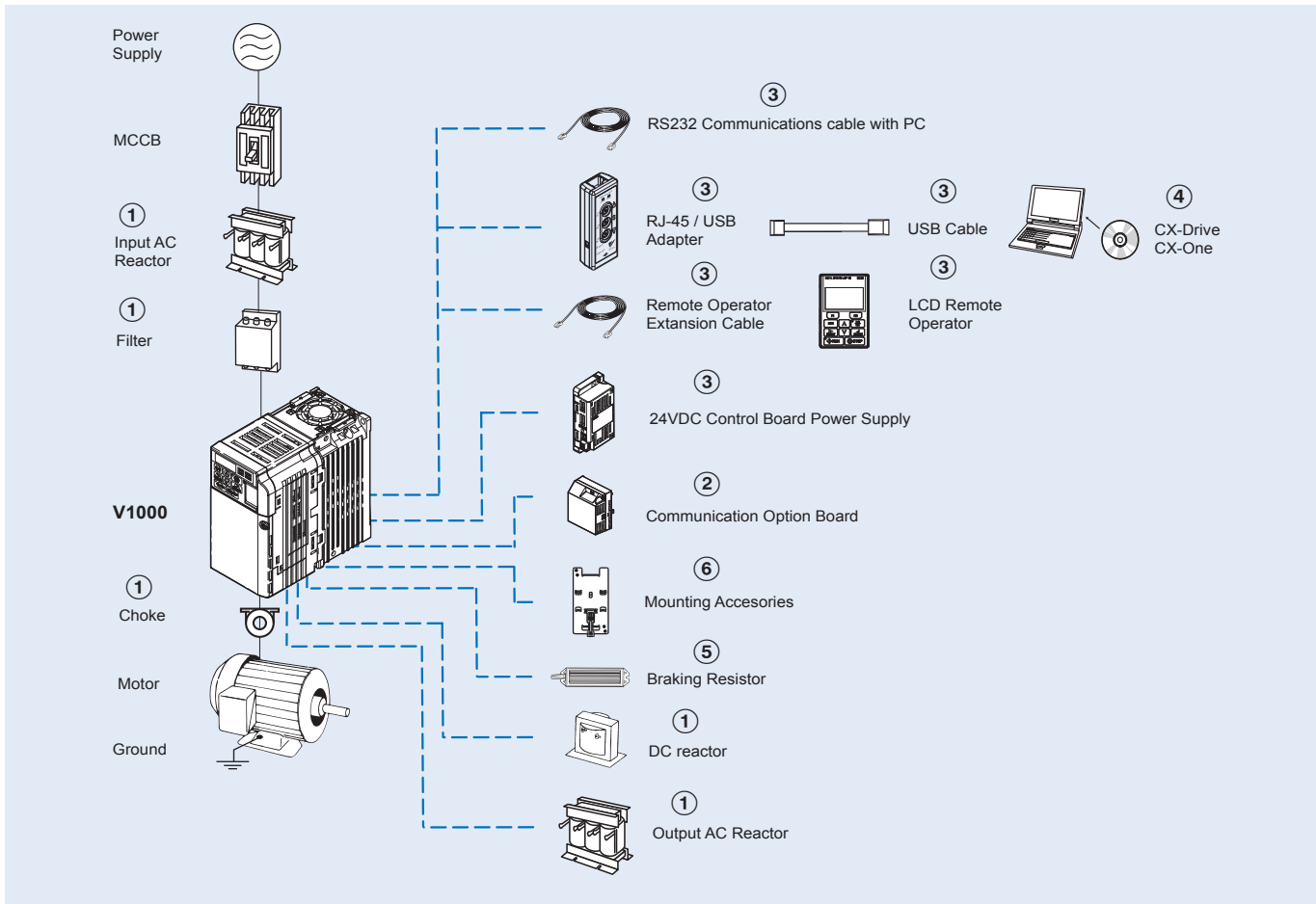

V1000

	Specifications				Model	
	Heavy Duty		Normal Duty		Standard	Built-in filter
1x200 V	0.12 kW	0.8 A	0.18 kW	0.8 A	VZAB0P1BAA	VZAB0P1EAA
	0.25 kW	1.6 A	0.37 kW	1.6 A	VZAB0P2BAA	VZAB0P2EAA
	0.55 kW	3.0 A	0.75 kW	3.5 A	VZAB0P4BAA	VZAB0P4EAA
	1.1 kW	5.0 A	1.1 kW	6.0 A	VZAB0P7BAA	VZAB0P7EAA
	1.5 kW	8.0 A	2.2 kW	9.6 A	VZAB1P5BAA	VZAB1P5EAA
	2.2 kW	11.0 A	3.0 kW	12.0 A	VZAB2P2BAA	VZAB2P2EAA
3x200 V	4.0 kW	17.5 A	5.5 kW	21.0 A	VZAB4P0BAA	-
	0.12 kW	0.8 A	0.18 kW	0.8 A	VZA20P1BAA	-
	0.25 kW	1.6 A	0.37 kW	1.6 A	VZA20P2BAA	-
	0.55 kW	3.0 A	0.75 kW	3.5 A	VZA20P4BAA	-
	1.1 kW	5.0 A	1.1 kW	6.0 A	VZA20P7BAA	-
	1.5 kW	8.0 A	2.2 kW	9.6 A	VZA21P5BAA	-
	2.2 kW	11.0 A	3.0 kW	12.0 A	VZA22P2BAA	-
	4.0 kW	17.5 A	5.5 kW	21.0 A	VZA24P0BAA	-
	5.5 kW	25.0 A	7.5 kW	30.0 A	VZA25P5FAA	-
3x400 V	7.5 kW	33.0 A	11.0 kW	40.0 A	VZA27P5FAA	-
	11 kW	47.0 A	15.0 kW	56.0 A	VZA2011FAA	-
	15 kW	60.0 A	18.5 kW	69.0 A	VZA2015FAA	-
	0.37 kW	1.2 A	0.37 kW	1.2 A	VZA40P2BAA	VZA40P2EAA
	0.55 kW	1.8 A	0.75 kW	2.1 A	VZA40P4BAA	VZA40P4EAA
	1.1 kW	3.4 A	1.5 kW	4.1 A	VZA40P7BAA	VZA40P7EAA
	1.5 kW	4.8 A	2.2 kW	5.4 A	VZA41P5BAA	VZA41P5EAA
	2.2 kW	5.5 A	3.0 kW	6.9 A	VZA42P2BAA	VZA42P2EAA
	3.0 kW	7.2 A	4.0 kW	8.8 A	VZA43P0BAA	VZA43P0EAA
	4.0 kW	9.2 A	5.5 kW	11.1 A	VZA44P0BAA	VZA44P0EAA
5.5 kW	14.8 A	7.5 kW	17.5 A	VZA45P5FAA	-	
7.5 kW	18.0 A	11.0 kW	23.0 A	VZA47P5FAA	-	
11 kW	24.0 A	15.0 kW	31.0 A	VZA4011FAA	-	
15 kW	31.0 A	18.5 kW	38.0 A	VZA4015FAA	-	

① Line filters

Inverter		Standard line filter				Low leakage line filter			
		Schaffner		Rasmi		Schaffner		Rasmi	
Voltage	Model VZA□	Reference A1000-FIV	Current (A)	Reference A1000-FIV	Current (A)	Reference A1000-FIV	Current (A)	Reference A1000-FIV	Current (A)
1-Phase 200 VAC	B0P1 / B0P2 / B0P4	1010-SE	10	1010-RE	10	1010-SE-LL	10	1010-RE-LL	10
	B0P7 / B1P5	1020-SE	20	1020-RE	20	1020-SE-LL	20	1020-RE-LL	20
	B2P2	1030-SE	30	1030-RE	30	1030-SE-LL	24	1030-RE-LL	30
	B4P0	1040-SE	40	1040-RE	40	1040-SE-LL	40	1040-RE-LL	40
3-Phase 200 VAC	20P1 / 20P2 / 20P4 / 20P7	2010-SE	8	2010-RE	10	2010-SE-LL	10	2010-RE-LL	10
	21P5 / 22P2	2020-SE	14	2020-RE	16	2020-SE-LL	20	2020-RE-LL	16
	24P0	2030-SE	24	2030-RE	26	2030-SE-LL	30	2030-RE-LL	26
	25P5 / 27P5	2060-SE	52	2060-RE	60	-	-	2060-RE-LL	60
	2011	2080-SE	68	2080-RE	80	-	-	2080-RE-LL	80
2015	2100-SE	80	2100-RE	100	-	-	2100-RE-LL	100	
3-Phase 400 VAC	40P2 / 40P4	3005-SE	5	3005-RE	5	3005-SE-LL	5	3005-RE-LL	5
	40P7 / 41P5 / 42P2 / 43P0	3010-SE	10	3010-RE	10	3010-SE-LL	10	3010-RE-LL	10
	44P0	3020-SE	15	3020-RE	15	3020-SE-LL	15	3020-RE-LL	15
	45P5 / 47P5	3030-SE	30	3030-RE	30	3030-SE-LL	30	3030-RE-LL	30
	4011 / 4015	3050-SE	50	3050-RE	50	3050-SE-LL	50	3050-RE-LL	50

① Input AC reactors

Inverter		AC Reactor
Voltage	Model VZA□	Reference
1-Phase 200 VAC	B0P1 / B0P2 / B0P4	AX-RAI02000070-DE
	B0P7	AX-RAI01700140-DE
	B1P5	AX-RAI01200200-DE
	B2P2	AX-RAI00630240-DE
	B4P0	-
3-Phase 200 VAC	20P1 / 20P2 / 20P4 / 20P7	AX-RAI02800080-DE
	21P5 / 22P2 / 24P0	AX-RAI00880200-DE
	25P5 / 27P5	AX-RAI00350335-DE
	2011 / 2015	AX-RAI00180670-DE
3-Phase 400 VAC	40P2 / 40P4 / 40P7 / 41P5	AX-RAI07700050-DE
	42P2 / 43P0 / 44P0	AX-RAI03500100-DE
	45P5 / 47P5	AX-RAI01300170-DE
	4011 / 4015	AX-RAI00740335-DE

① DC reactors

200V 1-phase		200V 3-phase		400V 3-phase	
Model VZA□	DC Reactor	Model VZA□	DC Reactor	Model VZA□	DC Reactor
B0P1	AX-RC10700032-DE	20P1	AX-RC21400016-DE	40P2 / 40P4	AX-RC43000020-DE
B0P2		20P2		40P7	AX-RC27000030-DE
B0P4	AX-RC06750061-DE	20P4	AX-RC10700032-DE	41P5	AX-RC14000047-DE
B0P7	AX-RC03510093-DE	20P7	AX-RC06750061-DE	42P2	AX-RC10100069-DE
B1P5	AX-RC02510138-DE	21P5	AX-RC03510093-DE	43P0	AX-RC08250093-DE
B2P2	AX-RC01600223-DE	22P2	AX-RC02510138-DE	44P0	AX-RC06400116-DE
B4P0	-	24P0	AX-RC01600223-DE	45P5	AX-RC04410167-DE
-	-	25P5	AX-RC01110309-DE	47P5	AX-RC03350219-DE
		27P5	AX-RC00840437-DE	4011	AX-RC02330307-DE
		2011	AX-RC00590614-DE	4015	AX-RC01750430-DE
		2015	AX-RC00440859-DE	-	-

## ① Chokes

Model	Diameter	Description
AX-FER2102-RE	21	For 2.2 KW motors or below
AX-FER2515-RE	25	For 15 KW motors or below
AX-FER5045-RE	50	For 45 KW motors or below

## ① Output AC reactor

Inverter		AC Reactor
Voltage	Model VZA□	Reference
200 VAC	B0P1 / B0P2 / B0P4 20P1 / 20P2 / 20P4	AX-RAO11500026-DE
	B0P7 / 20P7	AX-RAO07600042-DE
	B1P5 / 21P5	AX-RAO04100075-DE
	B2P2 / 22P2	AX-RAO03000105-DE
	B4P0 / 24P0	AX-RAO01830160-DE
	25P5	AX-RAO01150220-DE
	27P5	AX-RAO00950320-DE
	2011	AX-RAO00630430-DE
400 VAC	2015	AX-RAO00490640-DE
	40P2 / 40P4 / 40P7 / 41P5	AX-RAO16300038-DE
	42P2	AX-RAO11800053-DE
	43P0 / 44P0	AX-RAO07300080-DE
	45P5	AX-RAO04600110-DE
	47P5	AX-RAO03600160-DE
	4011	AX-RAO02500220-DE
4015	AX-RAO02000320-DE	

## ② Communication cards

Type	Model	Description	Function
Communication option board	SI-N3/V	DeviceNet option card	• Used for running or stopping the inverter, setting or referencing parameters, and monitoring output frequency, output current, or similar items through DeviceNet communication with the host controller.
	SI-P3/V	PROFIBUS-DP option card	• Used for running or stopping the inverter, setting or referencing parameters, and monitoring output frequency, output current, or similar items through PROFIBUS-DP communication with the host controller.
	SI-S3/V	CANopen option card	• Used for running or stopping the inverter, setting or referencing parameters, and monitoring output frequency, output current, or similar items through CANopen communication with the host controller.
	SI-T3/V	MECHATROLINK-II option card	• Used for running or stopping the inverter, setting or referencing parameters, and monitoring output frequency, output current, or similar items through MECHATROLINK-II communication with the host controller.
	SI-ES3/V	EtherCAT option card	• Used for running or stopping the inverter, setting or referencing parameters, and monitoring output frequency, output current, or similar items through EtherCAT communication with the host controller.
	SI-EP3/V	PROFINET option card	• Used for running or stopping the inverter, setting or referencing parameters, and monitoring output frequency, output current, or similar items through PROFINET communication with the host controller.

## ③ Accessories

Types	Model	Description	Functions
Digital operator	JVOP-180	LCD remote operator	LCD Display operator with language support
	A1000-CAVOP300-EE	Remote operator cable	3 meters cable for connecting remote operator
Accessories	JVOP-181	USB converter / USB cable	USB converter unit with copy and backup function
	PS-V10S	24 VDC option board	24VDC control board power supply VZA-B/2/4 from 0.1 to 4 KW
	PS-V10M		24VDC control board power supply VZA-2/4 from 5.5 to 15 KW
	A1000-CAVPC232-EE	PC connection cable	RS232 PC tool connection cable

## ④ Computer software

Types	Model	Description	Installation
Software	CX-Drive	Computer software	Configuration and monitoring software tool
	CX-One	Computer software	Configuration and monitoring software tool

⑤ Braking unit, braking resistor unit

Voltage	Max. motor kW	Inverter		Connectable min. resistance Ω	Braking resistor unit		Braking torque %
		Inverter model VZA□			Inverter mounted type (3 %ED, 10 sec max)		
		1-phase	3-phase		Type AX-	Resist Ω	
200 V (single-/three-phase)	0.12	B0P1	20P1	300	REM00K1400-IE	400	135
	0.25	B0P2	20P2				120
	0.55	B0P4	20P4	200	REM00K1200-IE	200	120
	1.1	B0P7	20P7				70
	1.5	B1P5	21P5	60	REM00K2070-IE	70	190
	2.2	B2P2	22P2				120
	4.0	B4P0	24P0	32	REM00K4035-IE	35	135
	5.5	-	25P5				75
	7.5	-	27P5	9.6	REM00K6035-IE	35	55
	11	-	2011				40
15	-	2015	55				
400 V (three-phase)	0.37	-	40P2	750	2 x REM00K1400-IE	800	270
	0.55	-	40P4				270
	1.1	-	40P7	510	REM00K1400-IE	400	270
	1.5	-	41P5	240			130
	2.2	-	42P2	200	REM00K2200-IE	200	130
	3.0	-	43P0				215
	4.0	-	44P0	100	REM00K2120-IE	120	160
	5.5	-	45P5				140
	7.5	-	47P5	32	REM00K4035-IE	35	80
	11	-	4011				50
15	-	4015	20				55
					REM00K9020-IE	20	

⑥ Mounting accessories

Types	Model	Description	Applicable models VZA□
DIN Rail	EZZ08122A	Necessary to mount the inverter on a DIN rail	B0P1/B0P2/B0P4 20P1/20P2/20P4/20P7
	EZZ08122B		B0P7/B1P5 21P5/22P2 40P2/40P4/40P7/41P5/42P2
	EZZ08122C		B2P2 24P0 44P0
	EZZ08122D		B4P0
Heatsink external mounting attachment	100-034-075	Additional items to mount the inverter with the heatsink out of the panel	B0P1/B0P2 20P1/20P2
	100-034-076		B0P4 20P4
	100-034-077		20P7
	100-034-078		40P2
	100-034-079		B1P5 21P5/22P2 41P5/42P2/43P0
	100-034-080		B2P2 24P0 44P0
	100-036-357		B4P0
	100-036-418		B0P7 40P2/40P4
	100-036-300		25P5/27P5 45P5/47P5
	100-036-301		2011 4011/4015
	100-036-302		2015

ALL DIMENSIONS SHOWN ARE IN MILLIMETERS.  
To convert millimeters into inches, multiply by 0.03937. To convert grams into ounces, multiply by 0.03527.



element14

---

**EN** - For pricing and availability in your local country please visit one of the below links:

**DE** - Informationen zu Preisen und Verfügbarkeit in Ihrem Land erhalten Sie über die unten aufgeführten Links:

**FR** - Pour connaître les tarifs et la disponibilité dans votre pays, cliquez sur l'un des liens suivants:

[VZA4015FAA](#)

[VZA40P2BAA](#)

[VZA40P4BAA](#)

[VZA42P2BAA](#)

[VZA44P0BAA](#)

[VZA45P5FAA](#)

[VZA47P5FAA](#)

[VZAB0P2BAA](#)

[VZAB0P4BAA](#)

[VZAB0P7BAA](#)

[VZAB2P2BAA](#)

[VZAB4P0BAA](#)

**EN**

This Datasheet is presented by  
the manufacturer

**DE**

Dieses Datenblatt wird vom  
Hersteller bereitgestellt

**FR**

Cette fiche technique est  
présentée par le fabricant