

SINAMICS G130

Voltage Sensing Module 10 (VSM10)

Operating Instructions · 03/2013

SINAMICS

SIEMENS

SIEMENS

SINAMICS

SINAMICS G130 Voltage Sensing Module 10 (VSM10)

Operating Instructions

Safety information

1

General

2

Mechanical installation

3

Electrical installation

4

Technical specifications

5

Control version V4.6



03/2013

A5E02142235A

Legal information

Warning notice system

This manual contains notices you have to observe in order to ensure your personal safety, as well as to prevent damage to property. The notices referring to your personal safety are highlighted in the manual by a safety alert symbol, notices referring only to property damage have no safety alert symbol. These notices shown below are graded according to the degree of danger.

 DANGER
indicates that death or severe personal injury will result if proper precautions are not taken.
 WARNING
indicates that death or severe personal injury may result if proper precautions are not taken.
 CAUTION
indicates that minor personal injury can result if proper precautions are not taken.
NOTICE
indicates that property damage can result if proper precautions are not taken.

If more than one degree of danger is present, the warning notice representing the highest degree of danger will be used. A notice warning of injury to persons with a safety alert symbol may also include a warning relating to property damage.

Qualified Personnel

The product/system described in this documentation may be operated only by **personnel qualified** for the specific task in accordance with the relevant documentation, in particular its warning notices and safety instructions. Qualified personnel are those who, based on their training and experience, are capable of identifying risks and avoiding potential hazards when working with these products/systems.

Proper use of Siemens products

Note the following:

 WARNING
Siemens products may only be used for the applications described in the catalog and in the relevant technical documentation. If products and components from other manufacturers are used, these must be recommended or approved by Siemens. Proper transport, storage, installation, assembly, commissioning, operation and maintenance are required to ensure that the products operate safely and without any problems. The permissible ambient conditions must be complied with. The information in the relevant documentation must be observed.

Trademarks

All names identified by ® are registered trademarks of Siemens AG. The remaining trademarks in this publication may be trademarks whose use by third parties for their own purposes could violate the rights of the owner.

Disclaimer of Liability

We have reviewed the contents of this publication to ensure consistency with the hardware and software described. Since variance cannot be precluded entirely, we cannot guarantee full consistency. However, the information in this publication is reviewed regularly and any necessary corrections are included in subsequent editions.

Table of contents

1	Safety information	5
1.1	Warnings	5
1.2	Safety and application instructions	6
1.3	Components that can be destroyed by electrostatic discharge (ESD)	7
2	General	9
2.1	Safety information	9
3	Mechanical installation	11
4	Electrical installation	13
4.1	Overview	13
4.2	Connection diagram.....	14
4.3	Interface description.....	16
4.3.1	Electronics power supply X524.....	16
4.3.2	DRIVE-CLiQ interface X500	16
4.3.3	X520 analog inputs/temperature sensor.....	17
4.3.4	X521 three-phase line supply voltage sensing up to 100 V (phase-to-phase)	18
4.3.5	X522 three-phase line supply voltage sensing up to 690 V (phase-to-phase)	18
4.3.6	X530 neutral point grounding.....	19
4.3.7	Operating on an ungrounded line supply (IT system).....	20
4.3.8	Significance of the LEDs for the Voltage Sensing Module VSM10	20
5	Technical specifications	21

Safety information

1.1 Warnings

**⚠ WARNING****Dangerous electrical voltage**

Hazardous voltages are present when electrical equipment is in operation. Severe personal injury or substantial material damage may result if these warnings are not observed.

Only qualified personnel are permitted to work on or around the equipment.

These personnel must be thoroughly familiar with all the warnings and maintenance procedures described in these operating instructions.

The successful and safe operation of this device is dependent on correct transport, proper storage and installation, as well as careful operation and maintenance.

National safety guidelines must be observed.

**⚠ DANGER****Five safety rules**

When carrying out any kind of work on electrical devices, the "five safety rules" according to EN 50110 must always be observed:

1. Disconnect the system.
2. Protect against reconnection.
3. Make sure that the equipment is de-energized.
4. Ground and short-circuit.
5. Cover or enclose adjacent components that are still live.

Note**Use of copper cables for a UL-approved system**

For a UL-approved system use 60/75°C copper conductors only.

1.2 Safety and application instructions



 **DANGER**

Dangerous electrical voltage

This equipment is used in industrial high-voltage installations. During operation, this equipment contains live, bare parts. For this reason, they could cause severe injury or significant material damage if the required covers are removed, if they are used or operated incorrectly, or have not been properly maintained.

When the machines are used in non-industrial areas, the installation location must be protected against unauthorized access (protective fencing, appropriate signs).

Preconditions

The persons responsible for the safety of the plant must ensure that the following conditions are met:

- Basic planning work for the system and all work relating to transportation, assembly, installation, commissioning, maintenance and repairs is carried out by qualified personnel and checked by responsible, suitably skilled personnel.
- The Operating Instructions and machine documentation are always available.
- The technical specifications regarding the applicable installation, connection, environmental, and operating conditions are always observed.
- The plant-specific assembly and safety guidelines are observed and personal protection equipment is used.
- Unqualified personnel are forbidden from using these machines and working near them.

These Operating Instructions are intended for qualified personnel and only contain information and notes relating to the intended purpose of the machines.

The Operating Instructions and machine documentation are written in different languages as specified in the delivery contracts.

Note

Support by SIEMENS service centers

We recommend engaging the support and services of your local Siemens service center for all planning, installation, commissioning and maintenance work.

1.3 Components that can be destroyed by electrostatic discharge (ESD)

 CAUTION
<p>Components sensitive to electrostatic charge</p> <p>The board contains components that can be destroyed by electrostatic discharge. These components can be easily destroyed if not handled properly. If you do have to use electronic boards, however, please observe the following:</p> <ul style="list-style-type: none"> • You should only touch electronic boards if absolutely necessary. • When you touch boards, however, your body must be electrically discharged beforehand. • Boards must not come into contact with highly insulating materials (such as plastic parts, insulated desktops, articles of clothing manufactured from man-made fibers). • Boards must only be placed on conductive surfaces. • Boards and components should only be stored and transported in conductive packaging (such as metalized plastic boxes or metal containers). • If the packaging material is not conductive, the boards must be wrapped with a conductive packaging material (such as conductive foam rubber or household aluminum foil).

The necessary ESD protective measures are clearly illustrated in the following diagram:

- a = conductive floor surface
- b = ESD table
- c = ESD shoes
- d = ESD overall
- e = ESD wristband
- f = cabinet ground connection
- g = contact with conductive flooring

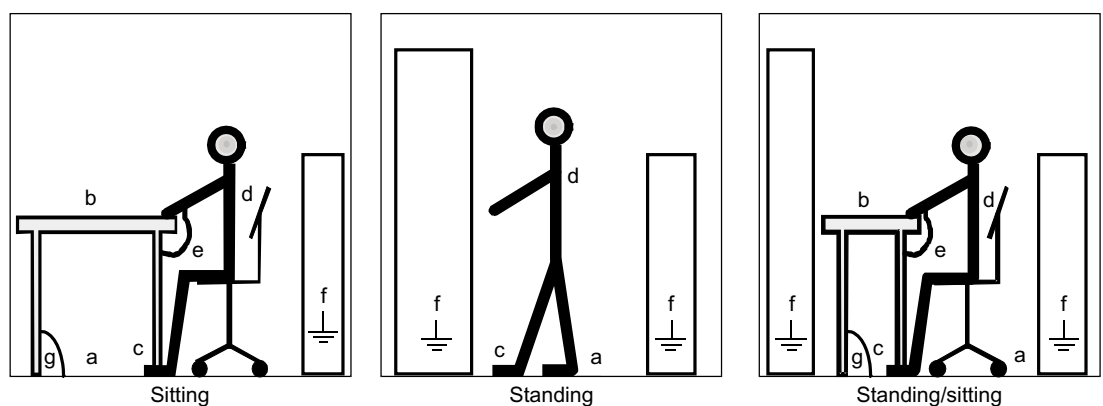



Figure 1-1 ESD protective measures

1.3 Components that can be destroyed by electrostatic discharge (ESD)

The Voltage Sensing Module VSM10 is used to operate a permanent-magnet synchronous machine without encoder with the requirement for switching to a machine which is already running (flying restart function).

To commission the function, the permanent-field synchronous machine without encoder must be input and "Flying restart" activated with p1200.

2.1 Safety information

 WARNING
Maintain ventilation clearances
The ventilation clearances of 50 mm above and below the components must be observed.

Note

Terminal blocks for voltage sensing

The VSM10 has two terminal blocks to sense the three-phase line supply voltage (X521 and X522). The voltage strength of terminal X521 is a maximum of 100 V (phase-to-phase) and is used for voltage sensing via a potential transformer. A maximum voltage to be sensed of up to 690 V (phase-to-phase) can be directly connected to terminal X522. Only one of the two terminals X521 and X522 may be used. Nothing may be connected to the unused terminal.

NOTICE
Using shielded cables
Temperature sensors must always be connected up using shielded cables. The cable shield must be connected to the chassis potential at both ends over a large surface area. Temperature sensor cables that are routed together with the motor cable must be twisted in pairs and shielded separately.

Mechanical installation

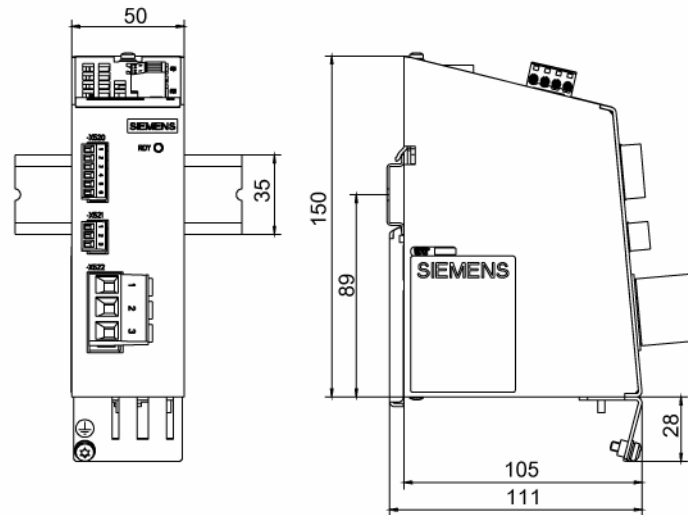

Figure 3-1 Dimension drawing of Voltage Sensing Module VSM10

Note

Mounting space

The VSM10 is installed near the Power Module on a mounting rail which must be provided by the customer.

Electrical installation

4.1 Overview

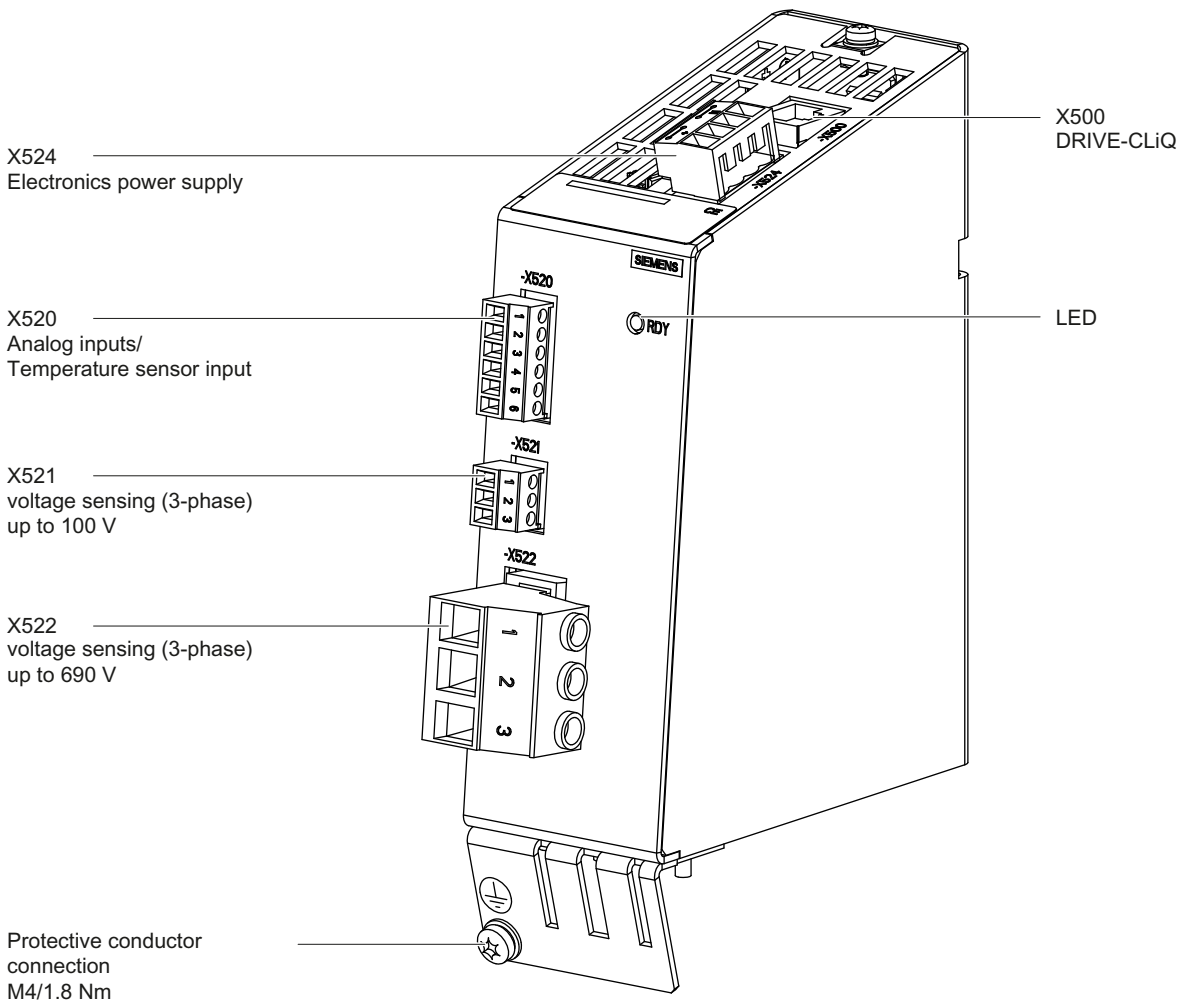

Figure 4-1 Voltage Sensing Module VSM10

4.2 Connection diagram

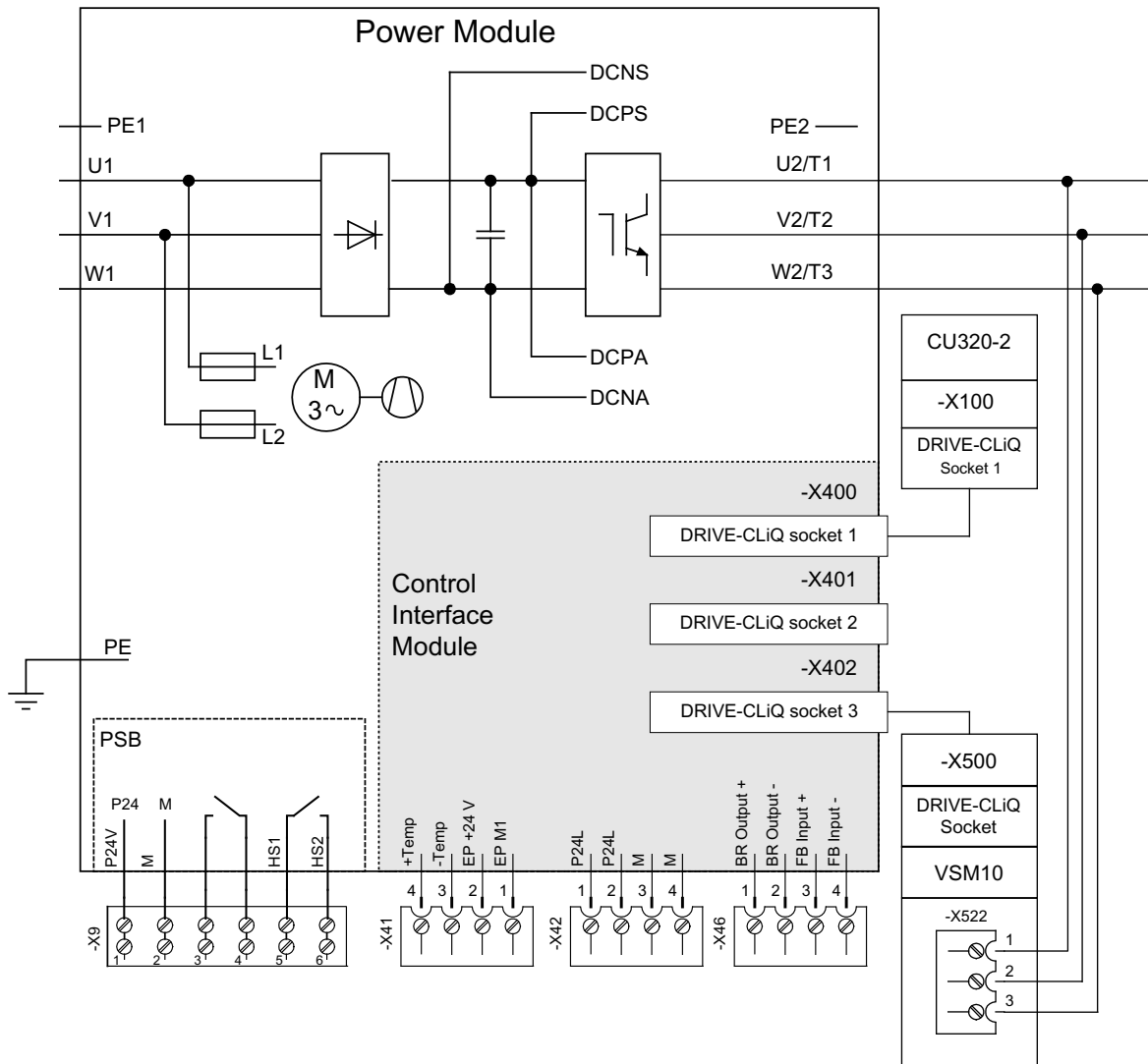

Figure 4-2 Connection example VSM10 for sensorless operation of a permanent-magnet synchronous machine

NOTICE

Pick-off for the cable to terminal -X522

The pick-offs for the cable to terminal -X522 must be located on the load side of an optional reactor or dV/dt filter, if possible directly at the motor connection terminals.

 **WARNING**

Risk of fire and damage to equipment due to short-circuit/ground fault

The cable to terminal -X522 must be installed in such a way that a ground fault or short circuit can be ruled out. A ground fault can result in fire with the associated smoke.

- Protect the cables from mechanical damage.
- Comply with local installation regulations that enable this fault to be ruled out.

In addition, apply one of the following measures:

- Use cables with double insulation.
- Maintain adequate clearance, using spacers, for example.
- Route the cables in separate cable ducts or pipes.

4.3 Interface description

4.3.1 Electronics power supply X524

Table 4- 1 Terminal strip for the electronics power supply X524

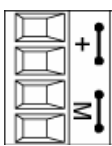
	Terminal	Designation	Technical specifications
	+	Electronic power supply	Voltage: 24 V DC (20.4 V – 28.8 V) Current consumption: Max. 0.2 A Max. current via jumper in connector: 20 A at 55°C
	+	Electronic power supply	
	M	Electronic ground	
	M	Electronic ground	

Max. connectable cross-section: 2.5 mm²

Note

Looping through the supply voltage

The two "+" and "M" terminals are jumpered in the connector. This ensures that the supply voltage is looped through.

4.3.2 DRIVE-CLiQ interface X500

Table 4- 2 DRIVE-CLiQ interface X500

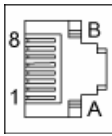
	Pin	Signal name	Technical specifications
	1	TXP	Transmit data +
	2	TXN	Transmit data -
	3	RXP	Receive data +
	4	Reserved, do not use	
	5	Reserved, do not use	
	6	RXN	Receive data -
	7	Reserved, do not use	
	8	Reserved, do not use	
	A	+ (24 V)	Power supply
	B	M (0 V)	Electronics ground

Blanking plate for DRIVE-CLiQ interfaces (50 pcs.) Order number: 6SL3066-4CA00-0AA0

4.3.3 X520 analog inputs/temperature sensor

Table 4- 3 Terminal block X520

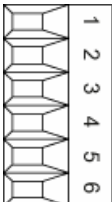
	Terminal	Designation	Technical specifications
	1	AI 0+	2 analog differential inputs Voltage range: ± 10 V Resolution: 13 bit Common-mode range ± 30 V with respect to ground potential
	2	AI 0-	
	3	AI 1+	
	4	AI 1-	
	5	+ Temp	Temperature sensor KTY84-1C130 / PTC
	6	- Temp	
Max. connectable cross-section: 1.5 mm ²			

 DANGER
<p>Hazard due to electric shock</p> <p>Only temperature sensors that meet the protective separation specifications laid down in EN 61800-5-1 may be connected to terminals "+Temp" and "-Temp".</p> <p>If these instructions are not complied with, there is a risk of electric shock!</p>

Note

KTY temperature sensor connected with the correct polarity

The KTY temperature sensor must be connected with the correct polarity.

Note

Use shielded cables

In order to minimize noise emission, shielded cables should be used.

Note

Maximum cable lengths

The maximum cable length for a shielded cable – connected at both ends – to the temperature sensor and to the analog inputs is 30 m.

4.3 Interface description

4.3.4 X521 three-phase line supply voltage sensing up to 100 V (phase-to-phase)

Table 4- 4 Terminal block X521

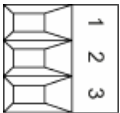
	Terminal	Designation	Technical specifications
	1	Phase voltage U	Connection for voltage sensing via a transformer with protective separation
	2	Phase voltage V	
	3	Phase voltage W	
Max. connectable cross-section: 1.5 mm ²			

Note

Use only one terminal strip

Only one of the two terminal strips X521 and X522 may be used. Nothing may be connected to the unused terminal strip.

Note

Connection sequence

The phases must be connected to the VSM10 with the same sequence as that of the Power Module.

4.3.5 X522 three-phase line supply voltage sensing up to 690 V (phase-to-phase)

Table 4- 5 Terminal block X522

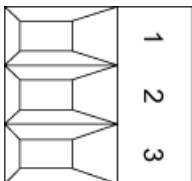
	Terminal	Designation	Technical specifications
	1	Phase voltage U	Directly connected to sense the line supply voltage
	2	Phase voltage V	
	3	Phase voltage W	
Max. connectable cross-section: 6 mm ²			

Note

Use only one terminal strip

Only one of the two terminals X521 and X522 may be used. Nothing may be connected to the unused terminal.

Note

The phases must be connected to the VSM10 with the same sequence as that of the Power Module.

The phases must be connected to the VSM10 with the same sequence as that of the Power Module.

4.3.6 X530 neutral point grounding

Table 4- 6 Neutral point grounding X530

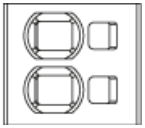
	Terminal	Designation	Technical data
	1	Neutral point of the voltage sensing	Jumper inserted: Grounded measurement
	2	Ground potential	Jumper not inserted: isolated measurement

The Voltage Sensing Module is supplied with inserted jumper. When delivered, the neutral point is connected to the protective conductor via the connector jumper. A current flows to PE as a result of the voltage to be measured. This connection is removed by removing the connector jumper. The measurement is then electrically isolated.

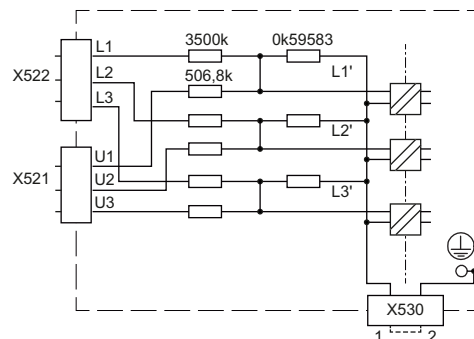
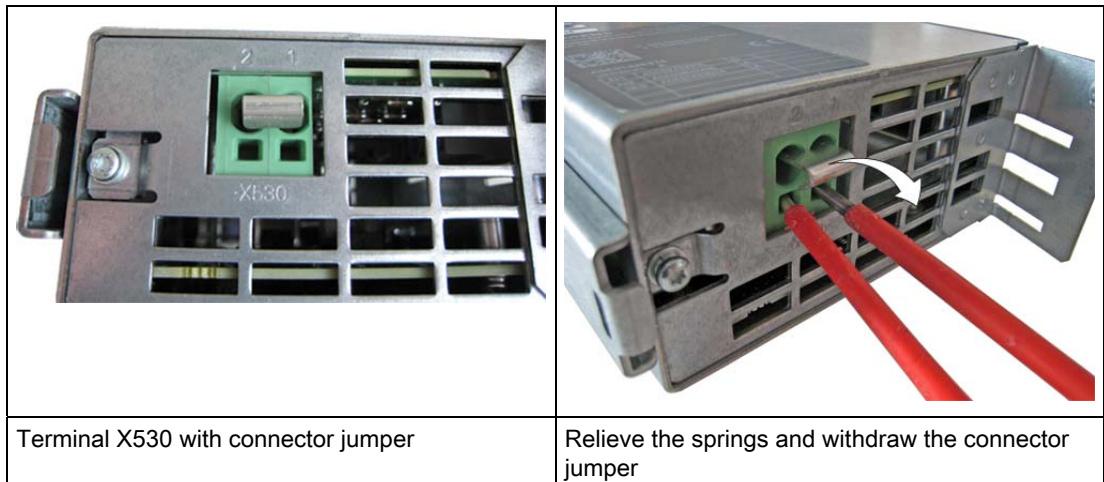

Figure 4-3 Internal circuit of the VSM10 Voltage Sensing Module

4.3.7 Operating on an ungrounded line supply (IT system)

When using a Voltage Sensing Module on an ungrounded line supply (IT system), remove the connector jumper in terminal X530 on the underside of the component.

Use two screwdrivers or a suitable tool in order to relieve the holding springs in the terminal and then withdraw the connector jumper.



4.3.8 Significance of the LEDs for the Voltage Sensing Module VSM10

Table 4- 7 Significance of the LEDs on the VSM10

LED	Color	Status	Description	
RDY	---	Off	The electronics power supply is missing or lies outside permissible tolerance range.	
	Green	Steady light	The component is ready for operation and cyclic DRIVE-CLiQ communication is taking place.	
	Orange	Steady light	DRIVE-CLiQ communication is being established.	
	Red	Steady light	At least one fault is present in this component. Note: The LED is driven irrespective of the corresponding messages being reconfigured.	
	Green / red		Flashing, 0.5 Hz	Firmware is being downloaded.
			Flashing, 2 Hz	Firmware download is complete. Waiting for POWER ON.
Green / orange or red / orange		Flashing, 2 Hz	Detection of the components via LED is activated (p0144). Note: Both options depend on the LED status when module recognition is activated via p0144 = 1.	

Technical specifications

General technical data

Table 5- 1 General technical data

Product standard	EN 61800-5-1
------------------	--------------

Technical data

Table 5- 2 Technical data

	Unit	Value
Electronic power supply		
Voltage	V _{DC}	24 DC (20.4 – 28.8)
Current (without DRIVE-CLiQ or digital outputs)	A _{DC}	0.3
Power loss	W	<10
PE/ground connection	On the housing with M4, 1.8 Nm screw	
Weight	kg	1
Degree of protection		IP20

Siemens AG
Industry Sector
Drive Technologies
Large Drives
P.O. Box 4743
90025 NUREMBERG
GERMANY

www.siemens.com/automation

Subject to change without prior notice
© Siemens AG, 2008 - 2013