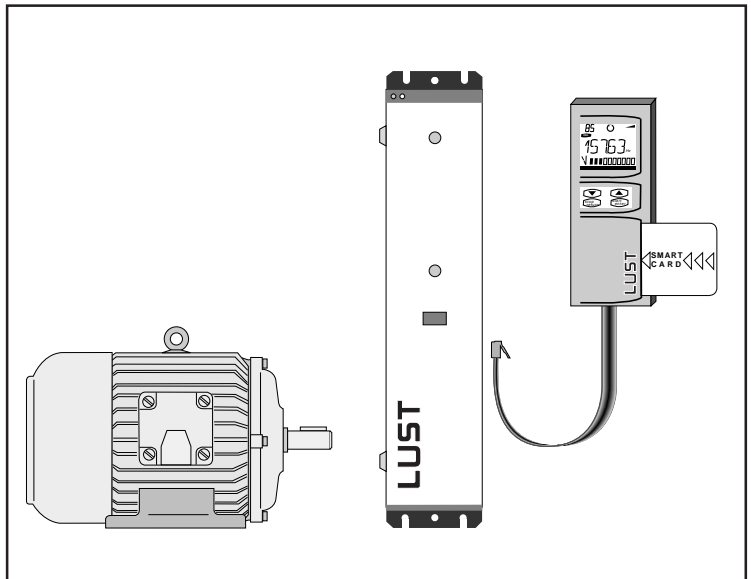


EN

SMARTDRIVE VF1000 · Series M

Frequency inverter 1.1 to 4 kW



Operation Manual
for static
frequency inverter

1 x 230 V - Version

VF1205M - 1.1 kW

VF1207M - 1.5 kW

3 x 400/460 V - Version

VF1404M - 1.5 kW

VF1406M - 2.2 kW

VF1408M - 3.0 kW

VF1410M - 4.0 kW

Applies as from software edition V 1.2

ID No.: 0809.21B.1-01

Issued January 2001

Dear customer!

Thank you for the trust which you have placed in us at Lust Antriebstechnik GmbH by purchasing the SMARTDRIVE frequency inverter.

Installation and commissioning should be carried out by a trained engineer. Please take the time to read this Operation Manual carefully before starting work. If you follow all the instructions, you will save yourself much time and many questions during the commissioning stage.

It is essential to read this Operation Manual because both the inverter itself and further components of the system can be damaged by improper handling.

If after reading the Manual, however, you still have questions, do please contact us as given below.

Lust Antriebstechnik GmbH
Gewerbestr. 5-9
D-35633 Lahnau
Phone: +49 64 41 966 - 0
Fax: + 49 64 41 966 - 137

A Useful information on the Operation Manual

The details in this manual apply for all frequency inverters belonging to the SMARTDRIVE VF1000M family of devices. The housing design is designated with the letter M for “Medium”.

The Operation Manual consists altogether of 6 chapters, which are listed under the title “Directly to your goal”.

General information about device versions, safety instructions as well as CE acceptance test is given.

Chapters 1, 2 and 3 are important for commissioning. Chapters 4, 5 and 6 relate to the operation of the inverter with the control unit KEYPAD KP100 and give information on the individual parameters.

According to the customer-specific requirements on the frequency inverter, there are also device versions with special functions. The specifications which deviate from those of the standard device are marked in the appropriate descriptions.

The following pictograms for warning and instruction occur in the Operation Manual to improve clarity.



⇒ Caution! Danger of death by electrocution.



⇒ Caution! It is essential that you follow these instructions.



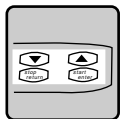
⇒ Caution! Disconnect device from mains and wait 2 minutes to allow the DC link capacitors to discharge.



⇒ Prohibited! Incorrect operation may cause damage to equipment.



⇒ Useful information, tip.



⇒ Setting with the KEYPAD is alterable.

Directly to your goal

A	Useful information on the Operating Manual	A-2
A	Directly to your goal	A-3
A.1	Safety instructions	A-5
A.2	Intended use	A-5
A.3	Design	A-7
A.4	Manufacturer's declaration for frequency inverter	A-8
A.5	VF1000M with CE - acceptance test	A-10
A.6	Instructions for correct EMC installation	A-12
1	Technical data	1-1
1.1	Assembly and layout plan	1-1
1.2	Data table	1-2
1.3	Scale drawing	1-3
1.4	Device assembly	1-4
2	Electrical connections	2-1
2.1	Connection plan	2-1
2.2	Fault transmission/fault resistance.(EMC).....	2-3
2.3	Power connections	2-4
2.3.1	Mains connection	2-4
2.3.2	Motor connection	2-5
2.3.3	Braking chopper (BR1)	2-5
2.3.4	Motor temperature monitoring (Design PTC/PT1)	2-6
2.4	Control connections	2-7
2.4.1	Specification	2-7
2.4.2	Function of the reference input FSINA	2-8
2.4.3	Control functions with STR/STL	2-11
2.4.4	Control function via S1IND/S2IND/S3IND	2-12
2.4.5	MOP function with S1IND/S2IND	2-14
2.4.6	Signal outputs	2-18
2.4.7	LUSTBUS connection (Design C9, C12)	2-20
2.4.8	INTERBUS-S connection (Design C8)	2-21
2.4.9	CAN-Bus connection (Design C2)	2-22
3	Operating and error diagnosis	3-1
3.1	Display	3-1
3.2	Warning messages	3-1
3.3	Error messages	3-2
3.4	Motor/inverter-overload protection (I * t monitoring)	3-3

4	Operating the control unit KEYPAD KP100*	4-1
4.1	Layout plan	4-1
4.2	In general	4-2
4.2.1	Menu branches	4-2
4.2.2	Key functions	4-2
4.2.3	LCD-display	4-3
4.3	Menu structure	4-4
4.3.1	Overview	4-4
4.3.2	MOP function with KEYPAD KP100	4-6
5	Parameter list	5-1
5.1	Operating level 1	5-1
5.2	Operating level 2 (Part 1)	5-2
	Operating level 2 (Part 2)	5-3
5.3	Inverter-type dependent and nationally related parameters	5-4
6	Parameter description	6-1
6.1	Reference input	6-1
6.2	Actual values	6-4
6.3	Frequencies	6-6
6.4	Ramps	6-6
6.5	Characteristics	6-8
6.6	Special functions	6-9
6.7	Signal outlets	6-15
6.8	Program functions	6-16

*Accessories

A.1 Safety instructions



While in operation, inverters may have live, uninsulated, also if required moving or rotating parts as well as hot surfaces, depending on the degree to which they are protected. This means that a frequency inverter drive is a source of potentially fatal injuries.

To prevent serious physical injuries or considerable material damage, only qualified persons familiar with electrical drive equipment may work on the device. Only those persons who are familiar with mounting, installing, commissioning and operating inverters and have appropriate qualifications shall be regarded as qualified. These persons must read the Operation Manual carefully before installation and commissioning and follow the safety instructions.

In this connection, the Standards IEC 364 and CENELEC HD 384 or DIN VDE 0100 and IEC-Report 664 or VDE 0110 and national accident prevention provisions or VBG 4 must be respectively observed.

Repairs to the equipment may only be carried out by the manufacture or by authorized workshops. Unauthorized opening and unprofessional intervention can result in physical injury or material damage.

A.2 Intended use

Inverters are components that are intended for installation in electrical systems or machines. They should be basically only used for installation in control cabinets.



When installed in machines, the inverter may not be commissioned (i.e. it may not be put to its intended use) until such time as it is established that the machine corresponds to the provisions of the EC Directive 89/392/EEC (Machine Directive), EN60204 should be observed.

In addition to the Directive on Low Potential 73/23/EEC the harmonized standards of the Series prEN 50178/DIN VDE 0160 in conjunction with EN 60439-1/DIN VDE 0660 Part 500 and EN 60146/DIN VDE 0558 are applied with regard to inverters.

The technical data and the information concerning conditions of connection can be taken from the type plate and the documentation and are to be adhered to under all circumstances.



The inverters should be protected against unauthorised loading. In particular components may not be bent and/or insulation distances changed during transport and use.

Inverters contain electrostatically endangered components, which can be easily damaged when incorrectly handled. Electrical components may not be mechanically damaged or destroyed.

When work is being carried out on live inverters, the applicable national accident-prevention regulations (e.g. VBG 4) should be observed.

Electrical installation should be carried out according to the applicable regulations (e.g. cable diameter, fusing, grounding cable connection). Additional details are contained in the documentation.

Electronic devices are not intrinsically fail-safe. The user himself shall be responsible for securing the drive if the device breaks down.

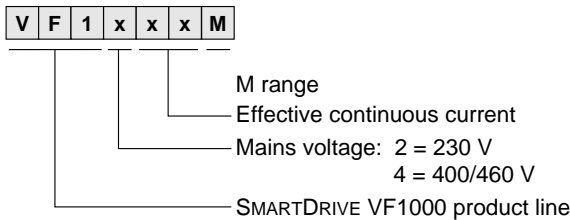


If the inverter is used for special applications (e.g. explosion-proof area), the required standards and regulations (e.g. EN50014 and EN50018), must be observed.

A.3 Design and accessories

The standard design of the VF1000M is only signified on the type plate. Other deviations from the standard are indicated by the appending of design codes to the type designation. Each design code has a special meaning.

Standard order or type designation



Standard design:

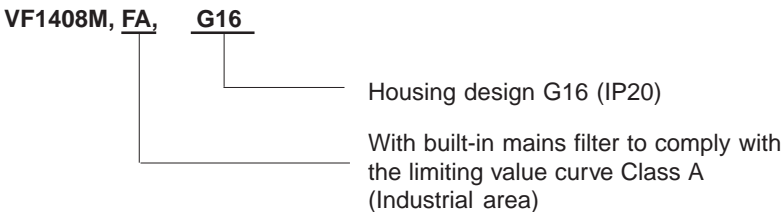
- Painted all metal housing with metal lid for KEYPAD KP100 installation, protection IP20
- With braking chopper power electronics, without braking resistance in the device cooling body
- Operation Manual

Design code when deviating from standard



The design code is separated with a comma and can be arranged in any sequence.

Example:



More precise details can be found in the "Data booklet VF1000".

A.4 Manufacturer's declaration for frequency inverter

Manufacturer's Declaration

Document No: 0809.04E.1 p 1/2
Month, Year: October 1996

Manufacturer: Company
Lust Antriebstechnik GmbH
Address: Gewerbestraße 5 - 9
D - 35633 Lahnau (Germany)
Tel.: 06441 / 966-0

Product Description: Frequency Inverter

Type: VF1203M; VF1205M; VF1207M;
VF1404M; VF1406M; VF1408M; VF1410M

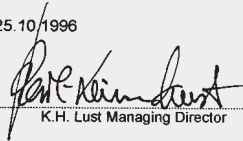
The product described is intended exclusively to be installed in another machine or in an installation in the sense of the Machinery Directive.
Commissioning is prohibited until such time as conformity of the end product with Directive 89/392/EEC is established.

The standards relevant to Directive 89/338/EEC (EMC) which have been used in type testing the product described are listed in the annexe.
In order to comply with EMC legislation the installation instructions described in the product documentation must be observed.

Manufacturer: Company
Lust Antriebstechnik GmbH

Place, Date: Lahnau, 25.10/1996

Legally binding signature:


K.H. Lust Managing Director

The annexe forms part of this declaration.
This declaration does not imply any assured characteristics.
The installation directions and safety instructions in the product documentation must be observed.

Annexe to Manufacturer's Declaration

Document No: 0809.04E.1 p 2/2
Month, Year: October 1996

Description: Frequency Inverter

Type: VF1203M; VF1205M; VF1207M;
VF1404M; VF1406M; VF1408M; VF1410M

Harmonized European Standards to EMC:

Title	Reference Number	Date of Issue
Generic Standard: Interference emission	EN 50081-1	1992
Part 1: Domestic		
Generic Standard: Interference immunity	EN 50082-2	1993
Part 2: Industrial		

National Standards:

Reference Number	Date of Issue	Reference Number	Date of Issue
.....
.....
.....
.....
.....
.....

IEC - Standards :

Reference Number	Date of Issue	Reference Number	Date of Issue
.....
.....
.....
.....
.....
.....

A.5 VF1000M with CE - acceptance test

Prüfzentrum für Umweltsimulation und Typprüfungen der CARL SCHENCK AG

AKKREDITIERT VON DER DEUTSCHEN AKKREDITIERUNGSSTELLE TECHNIK
(DATEch) e.V.



Zusammenfassung des Prüfberichtes Summary of protocol

Bericht-Nr. <hr/> 9 2 4

Deutscher Akkreditierungsrat



DAT-P-028/92-00

Gegenstand Object	Frequenzumrichter	Die Prüfung erfolgte auf der Grundlage des zwischen der Deutschen Akkreditierungsstelle Technik (DATEch) und CSD geschlossenen Vertrags.
Hersteller Manufacturer	Fa. Lust Antriebstechnik GmbH Gewerbestr. 5-9 D-35631 Lahnau	Dieser Prüfbericht dokumentiert die Rückführbarkeit auf die relevanten europäischen Richtlinien durch die Anwendung der von den Sektor-komitees des DATEch vorgegebenen technischen Begutachtungsbausteine.
Typ Item	VF 1207-M VF 1205 VF 1203	
Auftraggeber Customer	Fa. Lust Antriebstechnik GmbH	
Auftragsnummer Order No.	1 HID 3925	
Anzahl der Seiten des Prüfberichtes Report volume	63	
Datum der Anlieferung Date of delivery	07.08.95	
Datum der Prüfung Date of test	07.08.95-10.08.95	

Dieser Prüfbericht darf nur vollständig und unverändert weitergegeben werden. Auszüge bedürfen der Genehmigung des Prüfzentrums für Umweltsimulation und Typprüfungen (QST). Prüfberichte ohne Unterschrift und Stempel haben keine Gültigkeit. Die Prüfergebnisse beziehen sich ausschließlich auf den oben genannten Prüfgegenstand.
This test report may only be reproduced in full length. Extracts publishing needs permission of the issuing laboratory. Test result without signature and seal are not valid. The test results relating only the tested device.

Stempel 	Leiter der Prüfstelle  (K. Pätzsch)	Bearbeiter  (K.-P. Hielecher)
------------------------------------------------------------------------------------------------	------------------------------------------------------------------------------------------------------------------------------	------------------------------------------------------------------------------------------------------------------------

QEZ0004

All the inverters described in this Manual have passed the test at the Carl Schenk AG Test Centre and fulfilled the stated European norms. As an example, the CE-test certificate for the device VF1207M have been reproduced. Details of the test itself can be ordered from Lust Antriebstechnik GmbH.

3 Prüfergebnisse

Allgemein:

Bei diesem Schreiben handelt es sich um eine Zusammenfassung aller Messungen d.h. Diagramme, Tabellen, Fotos, Angaben zum Testaufbau, usw. sind nicht unbedingt Bestandteil dieses Schreibens. Die Meßwerterfassungsprotokolle (handschriftlich) enthalten alle Details und können unter der Angabe der Prüfnummer über das Prüfzentrum angefordert werden bzw. für Zulassungen kann ein Prüfbericht (QEZ0002) gemäß der EN 45 001 erstellt werden.

Die Anforderungen basieren auf europäische Fachgrundnormen (generics standards), diese ermöglichen die Beurteilung für die es keine produktspezifischen EMV-Normen gibt.

Die in der nachfolgenden Tabelle aufgeführten Prüfungen sind Konformitätstests gemäß dem EMV-Gesetz, für elektrische Betriebsmittel die für eine Verwendung im typischen Wohngebiet sowie im rauen Industriebereich vorgesehen sind.

Die Bewertung der Störfestigkeitsprüfungen erfolgte nach den Bewertungskriterien der EN 50082-2/03.95 (Generics).

Tabelle Prüfergebnisse:

Titel	EG-Richtl. Europäische Norm	Formular	erfüllt Ja / Nein	
Niederspannungsrichtlinie (SEB=Sicherheit elektrischer Betriebsmittel)	73/23/EWG prEN 50278:1994 EN 61010-1	QEF001	+	
EMV-Richtlinie bzw. EMVG Fachgrundnorm Störfestigkeit Teil 2: Industriebereich	89/336/EWG EN 50 082-2	QEF005	+	
EMV-Richtlinie bzw. EMVG Fachgrundnorm Störaussendung Teil 1: Wohngebiete	89/336/EWG EN 50 081-1	QEF007	+	

Bemerkungen zu den SEB-Prüfergebnissen:

Bei den sicherheitsrelevanten Prüfungen gab es keine Beanstandungen (siehe hierzu Prüfergebnisse SEB). Zusätzlich zur prEN 50178:1994 wurde die EN 61010-1:1993 herangezogen.

Bemerkungen zu den EMV-Prüfergebnissen:

Der Frequenzumrichter wird entsprechend des Einsatzgebietes mit den entsprechenden Netzfilter ausgeliefert (siehe Konfiguration auf Seite 3).

Ausgabe	Name	Datum	Seite
12.09.95	QST/Hielscher	924-Z4.TYP	8

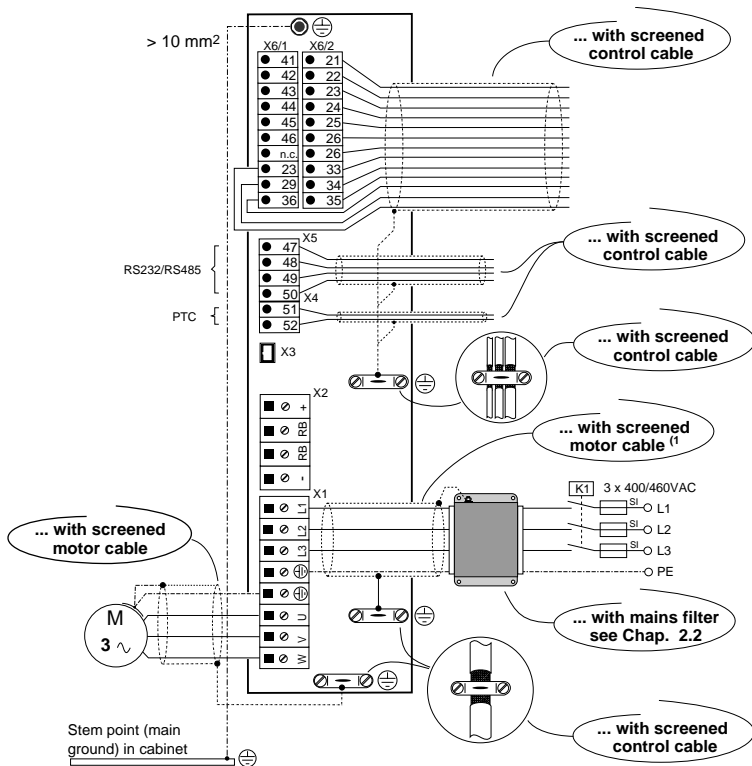
A.6 Instructions for correct EMC installation

According to EMC, means:

The VF1000M inverter series has been so developed, that not only the Low Voltage Directive is complied with, but also with suitable measures, the EMC Directives - even strict directives for residential areas can be observed. The acceptance of the device takes place under laboratory conditions at the accredited Schenk Commercial Test Centre and is not bindingly transferrable to a machine or system in its installed condition.

Installation information is given in the diagram below to aid the achievement of optimum installation.

You will achieve correct EMC installation ...



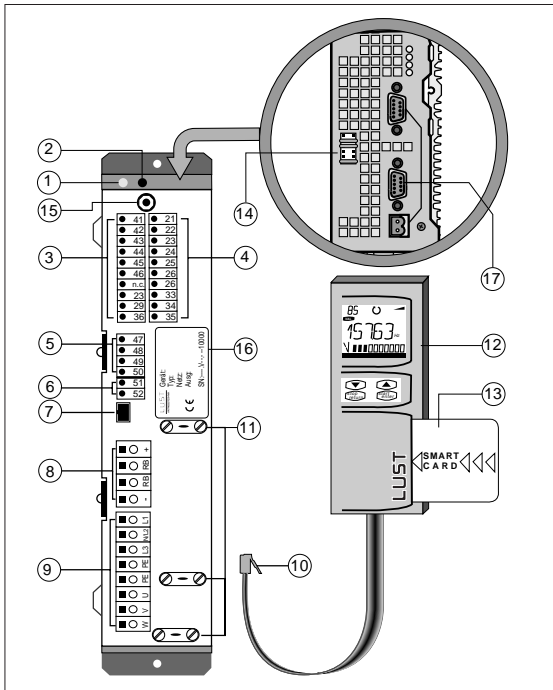
¹ Necessary cable lengths $> 0.3 \text{ m}$




Important: For further information see Chapter 2

1 Technical data

1.1 Assembly and layout plan



- | | |
|-----------------------------------------------------------------------------------|----------------------------------------------------------------------------------------------------------------------------|
| 1 LED H2 (green) operation indicator | 9 Terminal X1 power connections |
| 2 LED H1 (yellow) error indicator | 10 KEYPAD plug |
| 3 Terminal X6/1 control outputs | 11 EMC ground clamps for cable screen |
| 4 Terminal X6/2 control inputs | 12 Control unit KEYPAD KP100* |
| 5 Terminal X5 for interface design (RS485/RS232)** | 13 SMARTCARD* memory card |
| 6 Terminal X4, for motor PTC** | 14 Jumper rail J1 ... J6 |
| 7 Connection socket for X3 for control unit KEYPAD KP100 | 15  Connecting point for grounding line |
| 8 Terminal X2, connection for ext. braking resistance* and DC-link coupling (+,-) | 16 Type plate |
| | 17 Bus connections (CAN-Bus, INTERBUS-S, ...)** |

* Accessories, see data booklet VF1000

** Designs, see data booklet VF1000

1.2 Data table

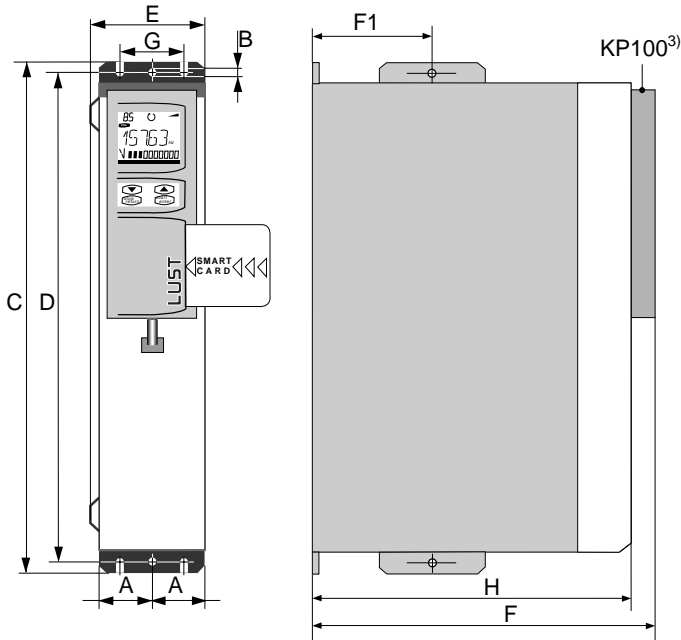
	Des.	Dim.	VF1205 M	VF1207 M	VF1404 M	VF1406 M	VF1408 M	VF1410 M
<i>Output on motor side</i>								
Recom. rated power with 4 pole standard motor	P	kW	1.1	1.5	1.5	2.2	3	4
Device power	S	kVA	1.9	2.6	2.6	4.0	5.3	6.3
Rated current ¹⁾ (230 V)	I_N	A	4.5	6.2	-	-	-	-
Rated current ¹⁾ (400/460 V)	I_N	A	-	-	3.5/3.1	5.5/4.7	7.2/6.3	8.9/7.7
Cont. current ¹⁾ (230 V)	$1.1xI_N$	A	5.0	6.8	-	-	-	-
Cont. current ¹⁾ (400/460 V)	$1.1xI_N$	A	-	-	3.8/3.4	6.0/5.1	7.9/6.9	9.8/8.5
Overload current ¹⁾ for 60s	$1.5xI_N$	A	6.8	9.3	5.3/4.7	8.3/7.7	10.8/9.5	13.3/11.6
Voltage	U	V	3 x 0...230		3 x 0 ... 400/460			
Rotary field frequency	f	Hz	0...400					
Frequency definition	f	%	0.1 of FMAX (0.05 Hz min.)					
Load type	-	-	ohmic/inductive					
Short circuit proof	-	-	at the terminals					
Ground-fault proof	-	-	according to each mains in.					
<i>Input on mains side</i>								
Mains voltage	U	V	1 x 230 +15/-20%		3 x 400/460 +10/-15%			
Mains frequency	f	Hz	50/60 +/- 10%					
Connection diameter	A	mm ²	max. 2.5					
Recom. fusing	I	AT	1 x 16	1 x 16	3 x 10	3 x 10	3 x 16	3 x 16
Assymetry of mains volt.	U	%	-		3 maximum			
<i>General</i>								
Operating mode	-	-	2 quadrats (4 quadrats) ²⁾					
Peak braking power ²⁾	P_{sp}	kW	1.65 max.					
Cyclical braking mode ²⁾	P_{eff}	W	90					
Power loss ³⁾	P_v	W	65	82	80	100	120	150
Efficiency ³⁾	η	%	95	95	95	95	95	95
<i>Ambient conditions</i>								
Cooling air temperature	T	°C	0 ... 40 (to 1000 m and NN)					
Ventilation type	-	-	Convection			force-ventilated		
Relative air moisture	-	%	15 ... 85 not saturated					
Power reduction in relation to cooling air temperature -	ΔP_T	-	2.5 % /°C (in range 40 ... 50 °C)					
Power reduction in relation to the installation height	ΔP_H	-	5 % per 1000 m (in range 1000 ... 2000 m and NN)					
Permissible vibration	-	-	2 g (IEC 68-2-6)					
<i>Mechanics</i>								
Weight (without packaging)	-	kg	3.75					
Protection	-	-	IP20, VBG4, NEMA 1					
Installation	-	-	upright wall mounting					

1) based on the switching frequency of the end level of 8 kHz

2) only with BR1 design

3) with rated voltage and rated current

1.3 Scale drawing



Dimension table

Device type	A	B	C	D	E	F	F1 ¹⁾	G	H
VF1205M...VF1404M	32.5	4.8 ϕ	330	315	69	260	112	40	245
VF1406M...VF1410M	32.5	4.8 ϕ	344 ²⁾	315	69	260	112	40	245

All dimensions in mm

¹⁾ For level assembly see Chapter 1.4 Device assembly

²⁾ Devices have a fan on their bottom side, also applies for **all** VF1000M devices equipped with integrated mains filter

³⁾ Accessories see data booklet VF1000

1.4 Device assembly

In general:

The installation site must be free from conductive and corrosive substances as well as dampness. Frequency inverters are intended for installation in cabinets with external air through-flow. They are fixed with 4 M4 screws on a mounting plate.

It is essential that the minimum distances above and below the device are observed to avoid overheating. The ventilation opening on the top side may not be covered or blocked under any circumstances.

The arrangement of several devices in a row is permissible.

Caution:

It should be ensured that foreign bodies such as drilling chips or screws do not drop into the device during installation of the inverter. This could result in destruction of the device.

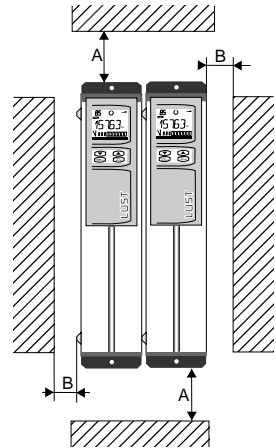


Installation distances:

Among other factors, the size of the cabinet is related to the power losses of the inverter (see power table). In order to avoid overheating in the cabinet, it is essential that the appropriate installation distances are observed. This guarantees safe long-term operation.

A = 100 mm

B = 50 mm

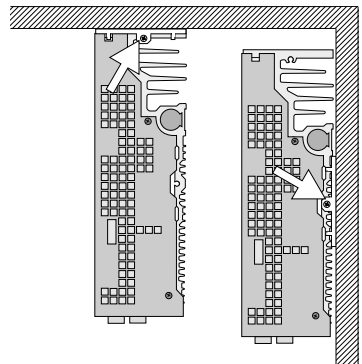


Level assembly:

Under special installation conditions it is possible to install the device level with the heat sink mounted against the wall. For this purpose the two supporting brackets must be re-mounted according to the drawing.

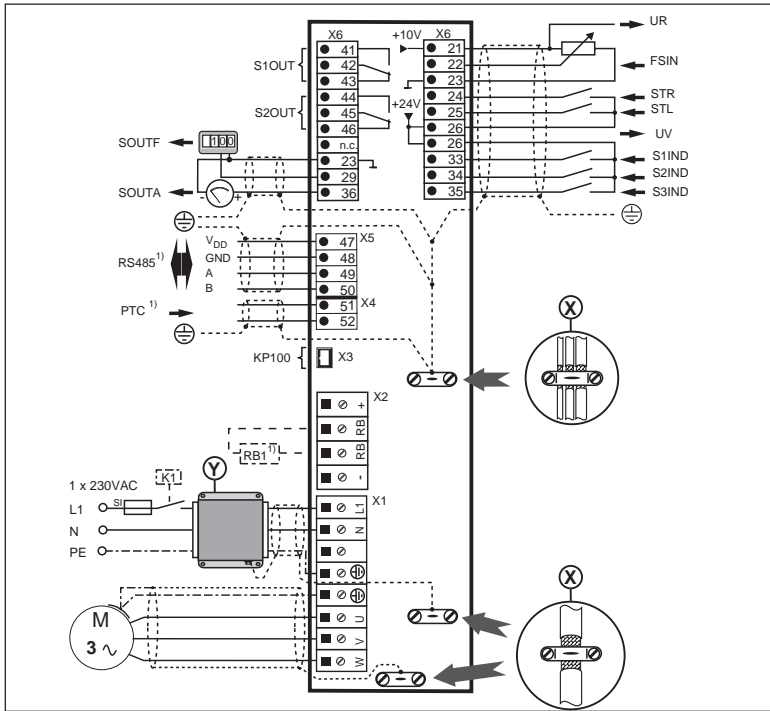
Exception:

Level installation is not possible with VF1406M, VF1408M, VF1410M and with all VF1000Ms with integrated network filter design



2 Electrical Connections

2.1 Connection plan



Attention:
Starting torque of terminal X1 and X2
max. 0,4-0,5 Nm

VF1205M
VF1207M

X6	Des.	Control connections
21	UR	Ref. voltage 10 V for ref. pot.
22	FSIN	Freq. ref. input
23	Ground	Control unit ref. point
24	STR	Start clockwise input
25	STL	Start counter-clockwise input
26	UV	Control voltage 24 V DC
29	SOUTF	Digital freq. output
33	S1IND	Prog. digital input
34	S2IND	Prog. digital input
35	S3IND	Prog. digital input
36	SOUTA	Prog. analog output
41	S1OUT	Break contact of relay 1
42		Cent. spring of relay 1
43		Make contact of relay 1
44	S2OUT	Break contact of relay 2
45		Cent. spring of relay 2
46		Make contact of relay 2

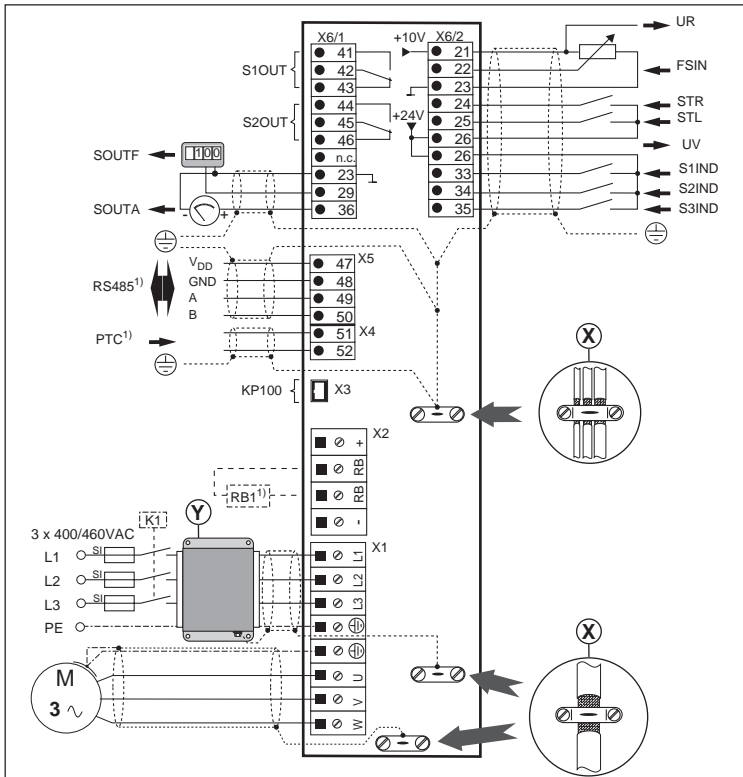
X1	Power connections
L1,N,⊕	Mains connection 1 x 230 V
⊕ U,V,W	Motor connection 3 x 230 V
X2/ +, -	Connection for DC-link coupling
X2/ RB	Connection for ext. braking resistor
X3	Socket for control unit KEYPAD KP100
X4/51, 52	Motor PTC connection ¹⁾
X5/ 47,48,49,50	Connection terminal for interface RS485 ¹⁾ or RS232 ¹⁾
K1	Example of mains protection connection
Y	Example of connection for ext. mains filter
⊕	Ground line
X	EMC ground clamps for easy installation of cable screen

1) Terminal assignment depends on design ordered 2-1



Attention:
Starting torque
of terminal X1
and X2
max. 0,4-0,5 Nm

VF1404M
VF1406M
VF1408M
VF1410M



21	UR	Ref. voltage 10 V for ref. pot.
22	FSIN	Freq. ref. input
23	Ground	Control unit ref. point
24	STR	Start clockwise input
25	STL	Start counter-clockwise input
26	UV	Control voltage 24 V DC
29	SOUTF	Digital freq. output
33	S1IND	Prog. digital input
34	S2IND	Prog. digital input
35	S3IND	Prog. digital input
36	SOUTA	Prog. analog output
41	S1OUT	Break contact of relay 1
42		Cent. spring of relay 1
43		Make contact of relay 1
44	S2OUT	Break contact of relay 2
45		Cent. spring of relay 2
46		Make contact of relay 2

X1	Power connections
L1,L2,L3 ⊕	Mains connection 3 x 400/460 V
⊕ U,V,W	Motor connection 3 x 400/460 V
X2/ +, -	Connection for DC-link coupling
X2/ RB	Connection for ext. braking resistor
X3	Socket for control unit KeyPAD KP100
X4/51, 52	Motor PTC connection ¹⁾
X5/ 47,48,49,50	Connection terminal for interface RS485 ¹⁾ or RS232 ¹⁾
K1	Example of mains protection connection
Y	Example of connection for ext. mains filter
⊕	ground line
X	EMC ground clamps for easy installation of cable screen

Caution: The connected mains may not exceed the following effective voltages for all devices in this manual:

VF1205M... VF1207M	L1 ->	N	230VAC
	L1 ->	⊖	230VAC
VF1404M... VF1410M	L1 -> L2 ->	L3	460VAC
	L1/L2/L3 ->	⊖	270VAC



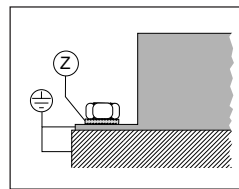
2.2 Fault transmission/interference immunity (EMC)

All SMARTDRIVE frequency inverters of the M series fulfil the requirements of EMC interference immunity in industrial areas according to the EC Directives/European Norms 89/336/EEC, prEN 50 062-2 (for this also see CE acceptance test in Chapter A).

The certified EMC testing of the fault resistance of the inverter is according to prEN 50082-2/01.93.

It is essential the following instructions are observed when installing an inverter in a machine for example, so that the EMC statute is complied with:

- ⇒ The motor cable, the mains cable and the control cables should be separated from each other and screened.
- ⇒ The device should be screwed onto a well grounded mounting plate. A toothed washer (Z) must be placed under each of the fixing screws of the device, so that the inverter housing has good contact to the mounting plate.
- ⇒ The screen of the mains and motor cable is clamped in place directly with the conductive cable clamps labelled in the circuit diagram.
- ⇒ The screen of the control cables is also directly clamped in place with the cable clamps labelled in the circuit diagram. As long as the sum of diameters allow it, several control cables can be clamped under one cable clip.
- ⇒ The terminal box of the motor must be HF-proof. It must therefore be made from metal or metallised plastic.
- ⇒ The bushing for the motor cable at the terminal box should be made from a conductive cable screw connection with screen linkage.



2.3 Power connections

2.3.1 Mains connection

In general

The inverters must be connected to the mains according to VDE regulations, so that they can be isolated from the mains at any time with appropriate releasing devices e.g. main switches.



Note:

Once the inverter is connected to the mains, the internal DC-link is then loaded. This means that the inverter is not ready for operation until a certain switch-on delay has elapsed. Hence mains connection can only be repeated at long time intervals (**at least 60 s**). Jogging operation with the mains protection is not possible.



Caution:

Due to the high current flows (> 3.5 mA) the use of fault current breakers on their own is not permissible. Hence a ground line is urgently prescribed.

The mains fusing must be laid out, according to the current loading of the connecting cable according to DIN 57100 (see recommendation in the power table). When using circuit breakers, only those with triggering characteristics B or C can be employed.

VF1205M, VF1207M connection

The mains connection (1 x 230 V) is via terminals L1, N, .

Technical data see data table.



Caution!

Never connect 400/460 V to terminals L1 and N. The device would be destroyed by the excess voltage.

VF1404M ... VF1410M connection

The mains connection (3 x 400/460V) is via terminals

L1, L2, L3, . Technical data see data table.

2.3.2 Motor connection

In general:

Standard phase motors are designed in the power range up to 4 kW according to IEC34 for various mains supplies in delta- ($3 \times 230 \text{ V}$) and in star-form ($3 \times 400 \text{ V}$).

When using special phase motors not in accordance with IEC34, information in relation to the connection type should be obtained from the manufacturer.



VF1205M, VF1207M connection

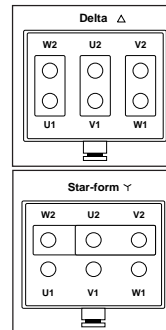
The motor connection is via terminals \oplus , U, V, W.

The motor must be connected to ($3 \times 230 \text{ V}$).

VF1404M... VF1410M connection

The motor connection is via terminals \oplus , U, V, W.

The motor must be connected to ($3 \times 400 \text{ V}$).



2.3.3 Braking chopper (BR1)

In general:

If the rotor speed is greater than the corresponding stator speed (rotary field of the inverter), the motor feeds energy back into the inverter. In this braking mode, the inverter brakes the motor, by means of the DC-link capacitors absorbing the braking energy.

BR1 design:

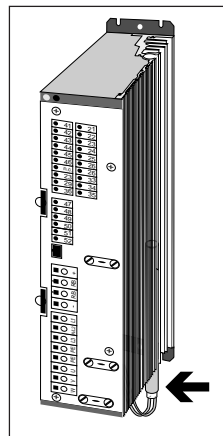
In this design, a braking resistance is built into the device's heat sink which is connected via the standard braking chopper electronics installed.

Peak braking power	$P_{BrSp} = 1650 \text{ W}$
Switching duration	$t_{on} = 12 \text{ s max.}$
switch-on duration	- = 6 %

Cyclical braking mode	$P_{BrD} = 90 \text{ W}$
-----------------------	--------------------------

Example:

Braking time:	Pause time:
$t_{on} = 12 \text{ s (6 \%)} \Rightarrow$	$t_{off} = 200 \text{ s (94 \%)}$
$t_{on} = 3 \text{ s (6 \%)} \Rightarrow$	$t_{off} = 50 \text{ s (94 \%)}$
$t_{on} = 1 \text{ s (6 \%)} \Rightarrow$	$t_{off} = 17 \text{ s (94 \%)}$



2.3.4 Motor temperature monitoring (PTC/ PT1 design)

A thermistor (PTC) or a thermal circuit breaker can be connected to the terminals X4/ 51 + 52 for monitoring the motor coil. The input is potential-free. There are 2 design versions available:

- PTC design** ⇒ Thermistor evaluation according to
DIN 44081/44082 with short circuit detection
- PT1 design** ⇒ For use of thermal circuit breaker (Klixon)

Specification:

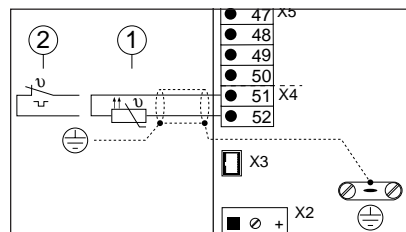
PTC and PT1 design		
Terminal voltage	U_{MAX}	$\leq 7.5 \text{ V}$
Current	I_{MAX}	$\leq 3 \text{ mA}$
Switching threshold	R_{ST}	3600Ω (nominal)
Reactivation value	R_{WST}	$< 1600 \Omega$
Only PTC design		
Switching point with short circuit	R_K	$< 50 \Omega$



Note: In the PTC or PT1 design, the device is supplied with an installed resistance (100Ω on CI. X4/51 or 52). When connecting a motor PTC or thermal circuit breaker, the resistance should be removed in advance.

Terminal assignment:

- (1) = Motor PTC
(2) = Thermal circuit breaker



2.4 Control connections

2.4.1 Specification

Connection	Specification
Reference output UR	10 V \pm 2.5% short circuit proof Load capacity max. 10 mA
Supply output UV	24 V \pm 10% short circuit proof Load capacity max. 100 mA
Frequency reference input FSIN (analog)	0...10 V, $R_i = 100 \text{ k}\Omega$ 4...20 mA, $R_i = 500 \Omega$ Resolution 10 BIT Deviation \pm 2.5% from final value Software filter up to 123 ms
Frequency reference input FSIN (digital)	LOW < 5 V, HIGH > 5 V (max. 30 V) Pulse width 10 ms min. Deviation \pm 0.8 %
Digital control inputs STR, STL, S1IND, S2IND, S3IND	LOW < 7 V, High > 14 V (max. 30 V) Current intake (at 24 V) = 10 mA max. SPS compatible, +24 V-logic against ground Hardware filter 3.3 ms
Digital frequency output SOUTF	Not short circuit proof, switching current = 12 mA LOW-Impulse, LOW-Level approx. 1 V Pulse-Pause Ratio 1 : 1 6-fold output frequency with stand still HIGH = 24 V (int. pull-up resist.)
Analog output SOUTA	Not short circuit proof Output voltage 10 V Load capacity (up to 10 V) = 8 mA Resolution 10 BIT
Relay outputs S1OUT, S2OUT	Switching voltage 250VAC Switching current 1 A max. Switching delay 10 ms max.

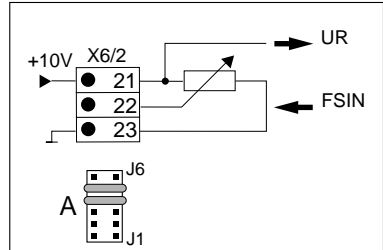
2.4.2 Function of the FSINA reference input

Analog frequency FSINA reference input

The rotary field frequency is preset via the X6/2-22 terminal. The input is adapted to the respective triggering method via the J3, J4, J5, J6 jumpers. There are three options for this:

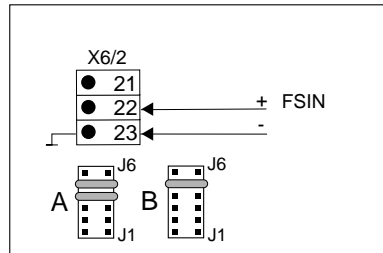
Connection of a potentiometer (4.7... 10 k Ω)

Adaption:
Jumper position A
04-FSSEL = 0 factory setting



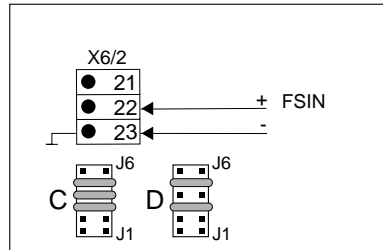
External voltage reference 0 (2)...10 V DC

Adaption:
Jumper position A 0... 10 V
Jumper position B 2... 10 V
04-FSSEL = 0 factory setting



External current reference 0(4)...20 mA

Adaption:
Jumper position C 0... 20 mA
Jumper position D 4... 20 mA
04-FSSEL = 0 factory setting



Position of jumpers J1...J6, on the device upper side (see layout plan Chap.1).

Note:

The inverter can be started via the frequency reference input with preset direction of rotation.

FS > 0.5 Hz → START

FS < 0.25 Hz → STOP

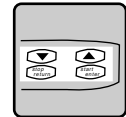
In addition to the adaption of the FSINA input to the jumper rail, the device software offers adaption options with the **KEYPAD** or via the interface.



The parameter 04-FSSEL (frequency reference selector) determines the origin of the frequency reference (see table). Also see parameter description.

FSINA(F) digital frequency reference input

04-FSSEL	Function
0	Analog input active, adaption via jumper rail J1...J6
1, 2	No function
3	FSIN as frequency input 0 to 1 kHz active
4	FSIN as frequency input 0 to 10 kHz active
5	FSIN as PWM input 20 to 100% active
6	FSIN as PWM input 0 to 100% active
7	FSIN not active, reference via KP100 (CTRL-menu)
8	Reference preset via interface
9 to 16	Reference presetting see Chapter 6 Page 6-4
17 to 22	Correction of the analog reference via S1IND/S2IND (MOP function) active
23	Inverted analog input: 10 V => FMIN, 0 V => FMAX



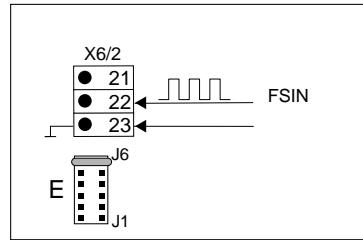
External frequency reference input 0...1 kHz

Scaling: FMIN → FMAX
0 ... 1 kHz

Adaption: Jumper position E
04-FSSEL = 3

Amplitude: 30 V max.

Impulse width: 10 μs min.



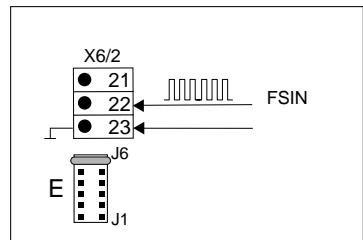
External frequency reference input 0 ... 10 kHz

Scaling: FMIN → FMAX
0 ... 10 kHz

Adaption: Jumper position E
04-FSSEL = 4

Amplitude: 10 V max.

Impulse width: 10 μs min.



External frequency reference default with PWM-Signal

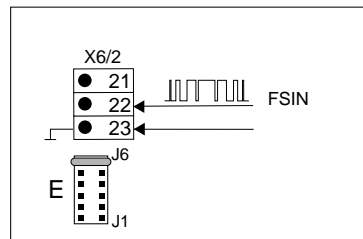
Scaling: 20 ... 100% (FMAX)

Adaption: Jumper position E
04-FSSEL = 5

Scaling: 0 ... 100% (FMAX)

Adaption: Jumper position E
04-FSSEL = 6

Condition: PWM basic frequency 0.9...8 kHz



For further details see Chapter 6.1 Reference input. Position of jumpers J1...J6, on the top side of the device (see layout plan, Chap.1).

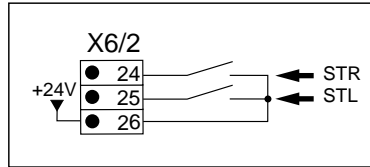
2.4.3 Control functions with STR/STL

Mains connection with STL/STR

For reasons of safety, the inverter may not be connected to the mains with the preselected control function STL or STR. The start function does not recognize the inverter until it has been activated **after** power on and self-test.



The direction of rotation is selected via the inputs STR or STL, using 2 switch contacts according to the circuit diagram. Alternatively, direction of rotation selection via 2 external voltage signals according to the specification of the control connections is also possible.



START

The inverter starts up when an STL or STR control signal and a reference for the rotary field frequency of at least $0.5 \text{ Hz} = 0.1 \text{ V}$ at FSIN are available.

STOP

The inverter stops when the STL or STR control signals are returned. The connected motor comes to a halt by itself, i.e. without braking.

BRAKING/STOP

The inverter brakes the motor until STOP, when two control signals are simultaneously available at STL and STR. When both signals are set to zero there is a restart.

REVERSING

The direction of rotation is reversed if the control signal is changed directly from one control input (e.g. STL) to another (e.g. STR).

The overlap time must be a min. of **8 ms**.

STL	STR	Explanation
0	0	STOP, Motor uncontrolled
1	0	START, Counter-clockwise with RACC/RDEC
0	1	START, Clockwise with RACC/RDEC
1	1	BRAKING, Motor is controlled to STOP
0	1	Reverse direction of rotation
1	0	

2.4.4 Control function via S1IND/S2IND/S3IND

Selection of fixed frequencies

In addition to the FSINA input, the frequency reference can be preselected via the control inputs S1IND/S2IND/S3IND as fixed frequency. 3 fixed frequencies can be selected, which can be activated according to the truth table.



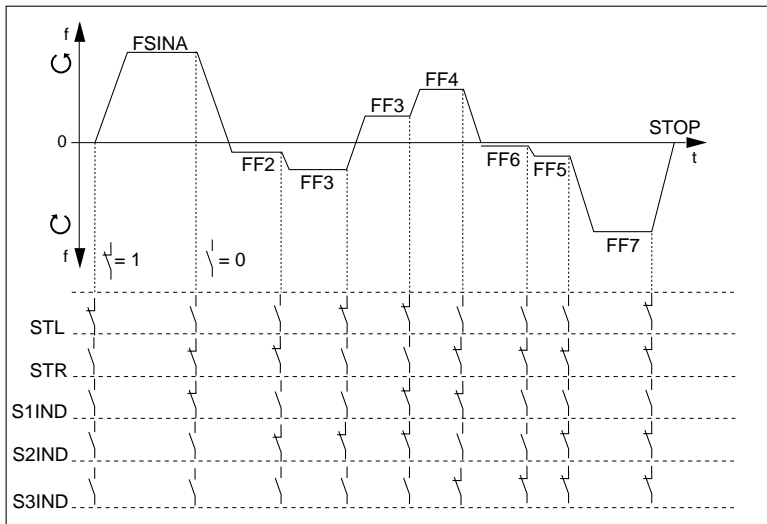
The truth table below relates to the factory settings, Parameter **31-KSEL = 0** (data set selector).

Truth table

S1IND	S2IND	S3IND	Speed reference	Factory setting
0	0	0	FSIN Analog input*	FMAX = 50 Hz
1	0	0	20-FF2-1 [27FF2-2]	FF2 = 5 Hz [3 Hz]
0	1	0	23-FF3	FF3 = 15 Hz
1	1	0	24-FF4	FF4 = 30 Hz
0	0	1	25-FF5	FF5 = 3 Hz
1	0	1	26-FF6	FF6 = 0 Hz
0	1	1	30-FF7	FF7 = 50 Hz
1	1	1	22-FMAX1 [29-FMAX2]	FMAX = 50 Hz

*Note the setting of 04-FSSEL.

Example of sequence diagram



Data set changeover

The inverter has two data sets, which can be switched with the control inputs S1IND/S2IND. Each data set has a total of 18 parameters, which can be set individually (see parameter description).

The truth table below refers to parameter **31-KSEL = 2** (data set selector)



Truth table

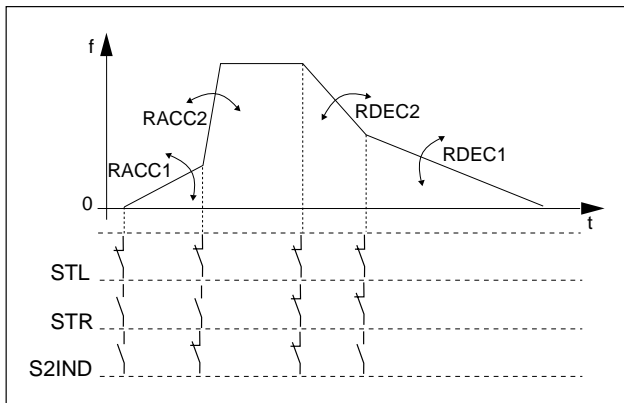
S1IND	S2IND	Explanation	Data set
0	0	FSINA input active	1 active
1	0	FF2-1 fixed frequency active	1 active
0	1	FSINA input active	2 active
1	1	FF2-2 fixed frequency active	2 active

Ramp changeover

As a consequence of the data set changeover option, the inverter has 2 ramp pairs available. The following sequence diagram illustrates the function of the ramp changeover (with 31-KSEL = 2).

For more detailed information see parameter description.

Sequence diagram



2.4.5 MOP function with S1IND/S2IND

Definitions

Base value preset analog speed reference at FSIN input

Offset Ratio of elevation or lowering from base value, influenced by inputs S1IND and S2IND

S1IND Input of offset setting for reference increase








S2IND Input of offset setting for reference decrease

Reference input, which is raised or lowered by the ratio of the offset (Base value +/- Offset)

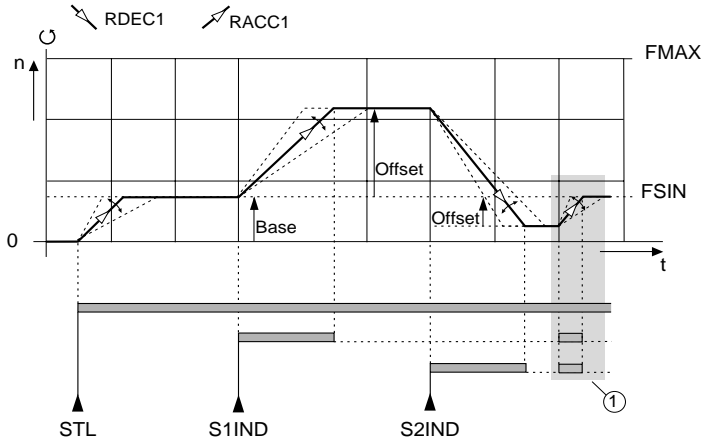


04-FSSEL = >	17	18	19	20	21	22
Reset offset with S1IND = 1, S2IND = 1		x		x		x
Reset offset with braking ramp RSTOP					x	x
Retain offset when power off (EEPROM memory)			x	x		

Explanation of diagrams in examples:

-  Input active
-  Input inactive
-  RDEC1 Braking ramp with counter-clockwise rotation
-  RDEC1 Braking ramp with clockwise rotation
-  RACC1 Acceleration ramp with clockwise rotation
-  RACC1 Acceleration ramp with counter-clockwise rotation
-  RSTOP Braking ramp (Param. 36-RSTOP)

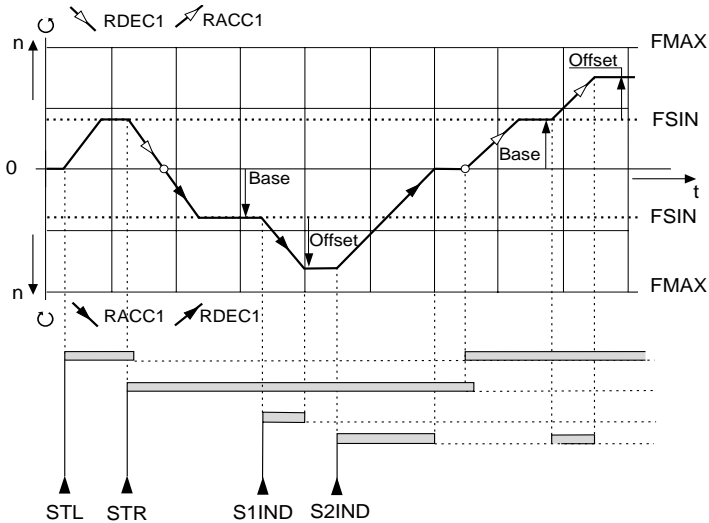
Example: Basic function with reset to base value



Key: ① Resetting of the reference to the base value (only possible with 04-FSSEL = 18/20/22).

Example: Direction of rotation with STL and STR

The setting parameter applies 04-FSSEL = 17/18/19/20/21/22



Note: When reversing, the signals at STL and STR must overlap by at least. 0.5 s.



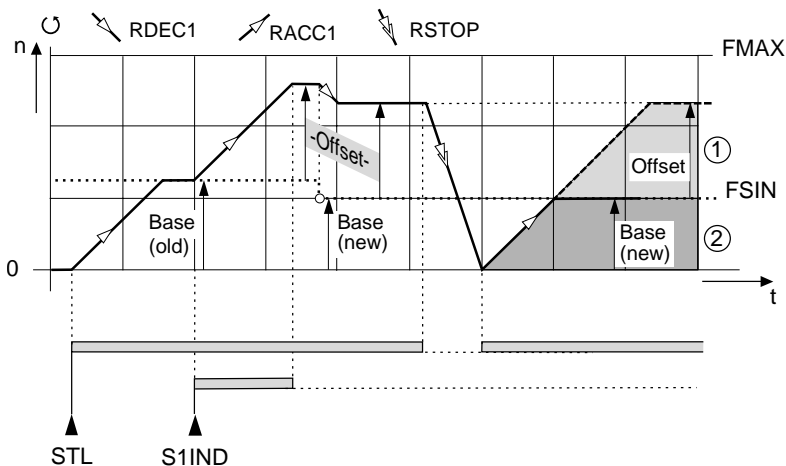
Example: Reduction of the base value, reset offset with RSTOP

With setting parameter applies 04-FSSEL = 17/18/19/20/21/22

Important: The braking ramp RSTOP is only active, if a value ≥ 1 Hz/s is set in the parameter (factory setting = 0 Hz/s).



Caution: With the reduction of the base value to 0 Hz the drive comes to a stand still, however the condition should not be confused with a stop command. If the base value is raised while the S2IND signal is at hand, the drive is restarted (to new base value with old offset).



Key:

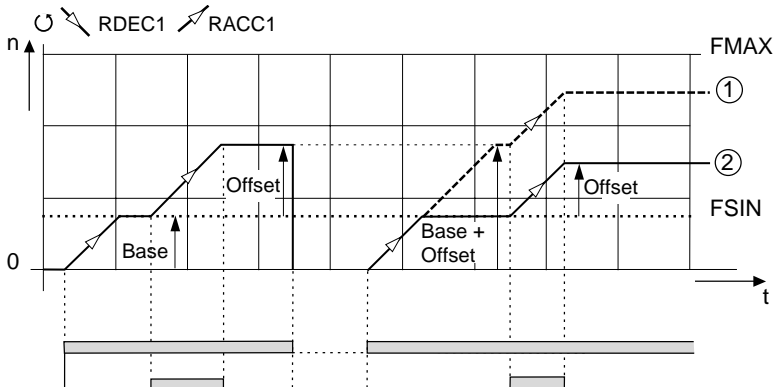
- ① Only possible with 04-FSSEL = 17/18/19/20
(Offset is retained)
- ② Only possible with 04-FSSEL = 21/22
(Offset is reset)

Example: Saving the offset after power off

Note: If the mains is switched off, the drive comes to a stop by itself. When the mains is reconnected and a new start signal, the drive is accelerated from 0 Hz.

If the STL contact remains active during power off, the drive does not start. The drive does not accelerate to the base value until after a new STL edge.

If an automatic restart required after power return, the auto start function must be activated in the parameter 72-STRT (see Chapter 6).



Key:

- ① Offset is saved with power off
(only possible with 04-FSSEL = 19/20).
- ② Offset is lost with power off
(with 04-FSSEL = 17/18/21/22).

2.4.6 Signal outputs

S1OUT collective error message (Relay output)

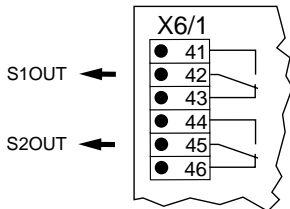
The operating contact Kl. 41/42 is closed, if there is a inverter malfunction. The contact opens again, if the fault has been rectified or the mains have been disconnected.



The error message is acknowledged by pressing the stop/return key for at least 3 secs or by a signal to one of the digital inputs (see Parameter 75-OPT1 Page 6-20).

S2OUT stand-by (Relay output)

The make contact Kl. 44/45 is closed, as soon as the pre-charging is completed after power on and there is no fault. The make contact Kl. 44/45 is opened, as soon as a fault arises or the mains is switched off.



Programming:

Both outputs can be set to one of 10 different functions with the **KEYPAD** or via the interface. The function description relates to the following factory settings:

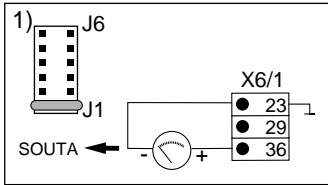
Parameter 62-S1OUT = 10

Parameter 63-S2OUT = 1

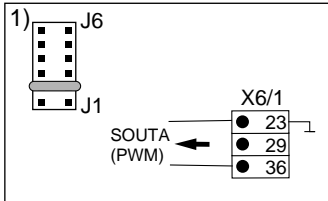
Further information see parameter description, Chapter 6.

SOUTA analog output

The output operates in the basic setting as an analog frequency output. It delivers a direct voltage, which is proportional to the output frequency of the inverter.



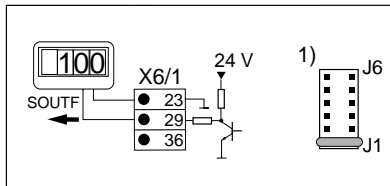
SOUTA (J1)	Explanation (61-SOUTA = 9)
0 V	F = 0 Hz
10 V	Inverter start, F = FMAX



SOUTA (J2)	Explanation (61-SOUTA = 9)
PWM = 0 %	F = 0 Hz
PWM = 100 %	Inverter start, F = FMAX

SOUTF digital frequency output

The output SOUTF supplies 24 V impulses. 6 LOW impulses are issued per 1 Hz rotary field frequency at the frequency output. At stand still, the output is at +24 V.



FSIN	SOUTF
< 5 Hz	30 Hz constant
5...260Hz	30...1560Hz linear
> 260 Hz	1560 Hz constant

1) Position of jumpers (J1...J6) at device top side (see layout plan Chapter 1).

Programming:

The outputs SOUTA and SOUTF can be programmed with KeYPAD or via the interface to further functions. For both outputs setting is undertaken with the parameter 61-SOUTA. In addition the analog output SOUTA can be scaled with the parameter 69-KOUTA.

Factory setting: 61-SOUTA = 9
69-KOUTA = 100%



For further information see parameter description

2.4.7 LstBus connection (Design C9/ C12)

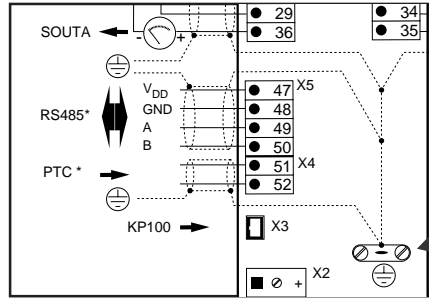
C9 design:

The VF1000 Series M inverters in this design have a potential-free interface connection **RS485**. The inverters can be operated via this interface according to the LstBus data transmission protocol.

Terminal assignment see Fig.:

An external 24 V DC supply (V_{DD}) is necessary to operate the interface.

Technical data:



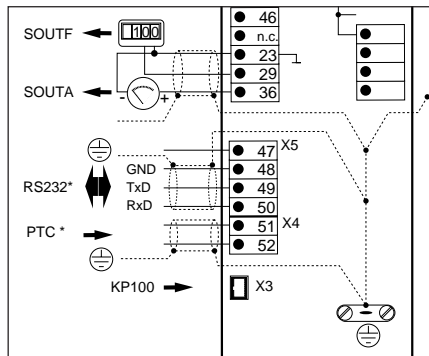
	Des.	RS485
Voltage supply ext.	V_{DD}	24 VDC \pm 15%
Current intake	I	approx. 50 mA
Isolation	-	corresponds to VDE 0884, Protective low voltage
Driver power	-	RS485: 31 participants, removal < 1000 m
Bus termination	-	not installed
Transmission rate	-	fixed 9600 Baud

C12 design:

The VF1000 Series M inverters in this design have a potential-free interface connection **RS232**. The inverters can be operated via this interface according to the LstBus data transmission protocol.

Terminal assignment see Fig.:

An external power supply is not necessary for the operation of the interface.



2.4.8 INTERBUS-S connection (Design C8)

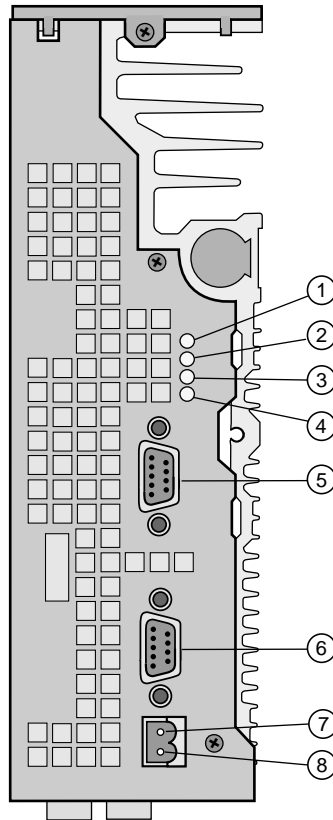
In general:

The inverter VF1000M in the **C8** design, has an INTERBUS-S coupling (IBS) with external 24 V supply and remote bus interface. The inverter can be operated according to the INTERBUS-S data transmission protocol.

Layout plan (view from above):

An external 24V DC power supply is necessary to operate the interface.

No.	Function
1	LED [RC] green
2	LED [RD] red
3	LED [BA] green
4	LED [U] green
5	X7 IBS input
6	X8 IBS output
7	KI.54, input +24 V
8	KI.53, GND



The screen connection is via the plug casing.

Connection assignment:

IBS output (9pin socket)	Des.	Function	IBS input (9 pins)
1	DO	Data Out	1
2	DI	Data In	2
3	COM	Ground	3
5	+ 5 V	Supply	
6	/DO	/Data Out	6
7	/DI	/Data In	7
9	RBST	Plug identification	
4, 8	n.c.	not assigned	4, 5, 8, 9

Technical data:

	Des.	VF1000M, INTERBUS-S
Supply voltage:	V_{DD}	24 V DC, - 7% +15%
Current intake:	I	approx. 100 mA
Interface design:	-	2 cable remote bus with ext. +24 V-supply
Module ID No.:	-	59
Data:	-	2 data words via process data channel (Control word and speed reference) according to DRIVECOM specification 1 Data word communication channel for parameterization

2.4.9 CAN-Bus connection (Design C2)

In general:

The VF1000 Series M inverter in the **C2 design** has the option of a CAN-Bus coupling (CAN). The Bus-Interface is isolated.

The bus is connected via two 9 pin Sub-D plugs in accordance with CiA Draft Standard 102.V2.0.

The inverters can be driven in a network with CAL protocol.

Technical data:

	Des.	VF1000M, CAN-Bus acc. to ISO 11898	
Participant number		maximum 30	
Power supply ext.	V_{DD}	24 VDC \pm 10%	
Current intake	I	100 mA max.	
Transmission rate	-	up to 1 M Baud	
Transmission and processing time		Time on the bus	Time in the inverter
Position command and subsequent status interrogation - for 1 inverter - for 30 inverters		0.3 ms 9 ms	9 ms 8 ms
Parameter presetting - for 1 inverter - for 30 inverters		0.15 ms 4.5 ms	approx. 30 ms approx. 30 ms

Layout plan:

To ensure uninterrupted operation of the interface, an external 24 V DC supply is necessary. Connection is via the D-Sub plug connection.

E = CAN input,
9 pin sub D pin rail X8

A = CAN output,
9 pin sub D socket rail X7

C = jumper rail J7 ... J11

The screen connection is via the plug casing.

Note:

No jumpers (plug-in bridges) are inserted in the jumper rail (J7 ... J11). They are enclosed with the device in a separate bag.

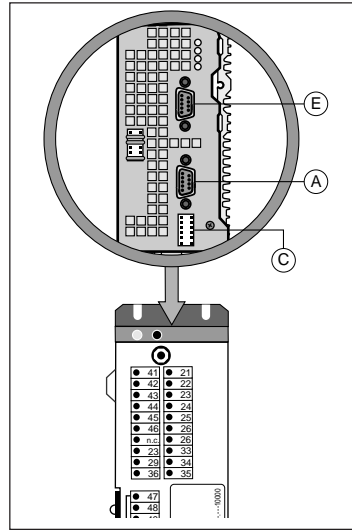


Fig. a

Connection assignment:

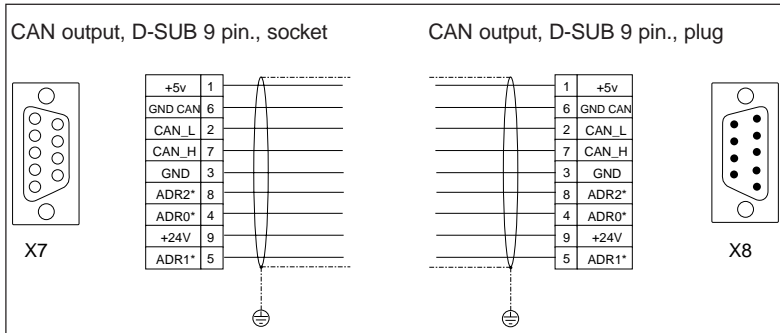


Fig. b

* Address preallocation is possible via the coding plug or optionally also via the jumper rail J7 ... J11 (not switched, if not necessary).

Address pre-allocation:

Addresses are allocated in binary (see table). The address pre-allocation can be achieved optionally via,

- a) a parameter
- b) a jumper rail J7 ... 11 on the top of the device (see Fig. c)
- c) via coding plug (ADR0, ADR1, ADR2) (see Fig. b).

J11	J10	J9 ADR2	J8 ADR1	J7 ADR0	Address
-	-				
0	0	0	0	0	0
0	0	0	0	1	1
0	0	0	1	0	2
:	:	:	:	:	:
0	1	0	0	0	8
:	:	:	:	:	:
1	1	1	0	1	29



Note: 0 = Jumper not inserted
1 = Jumper inserted
J12 is unassigned.

Assignment of the jumper position

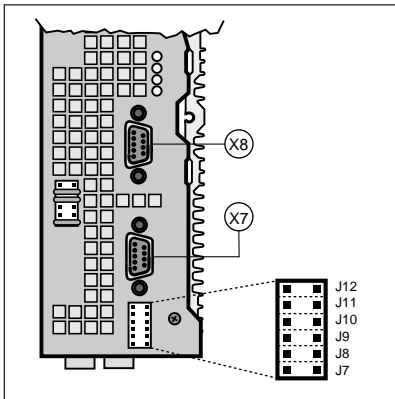


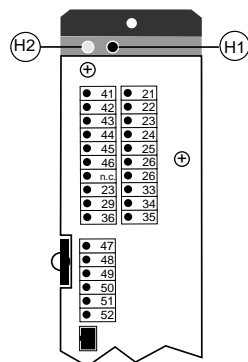
Fig. c

3 Operating and error diagnosis

3.1 Display

H1 yellow	H2 green	Meaning
○	●	Power off, no function
☀	●	Power is switched on, after approximately 0.5 s Selftest, inverter ready
○	☀	Inverter is started
☀	☀	Overload protection active
○	☀	Error shut-down, flash rhythm H1 see chap. 3.2.2. Error message

Position of LEDs:



3.2 Warning messages (no fault reaction from the device)

Inverter malfunction

ATT1	Parameter alteration in online- mode (when motor running) not allowed.
ATT2	Motor control via KEYPAD in online- mode not permitted.
ATT3	Access to LUST SMARTCARD in online- mode not permitted.
ATT4	System is in fault condition. Control via KEYPAD not permitted.
ATT5	Motor data must be complete for the selected function e.g. I * R Compensation.
ERROR	Invalid password

Acknowledge error by pressing start/enter-key.

Error with **SMARTCARD**-mode

ERR91	SMARTCARD is write-protected
ERR92	Error with plausibility check.
ERR93	SMARTCARD not readable, inverter/servo-controller type incorrect.
ERR94	SMARTCARD not readable, parameter incompatible.
ERR96	Connection to SMARTCARD interrupted.
ERR97	SMARTCARD - data invalid (CS-Test).
ERR98	Insufficient memory on SMARTCARD (only MC6000).

Acknowledge error by pressing stop/return-key.












Programming:

With the parameter 59-TRIP, the I*t-trigger current is set. That means currents $< I_N$ (device nominal current) can be set. Motors with outputs smaller than the device nominal output are thus sufficiently protected from overloading .

Factory setting: 59-TRIP = I_N (Device nominal current)

3.3 Error messages

H1 flashes	Errors	Condition/cause	Remedy/comment	
	once	E-CPU	Error in computer	Switch off at mains and switch on again (Reset)
	twice	E-OFF	Mains switched off or low voltage	flashes until U _{ZK} < 150 V VF12xxL < 300 V VF14xxL
	3 times	E-OC	Excess current cut-off short circuit	Check drive/ motor cable/ U/f characteristics
	4 times	E-OV	Excess voltage, Motor generator	Check mains/drive/ braking chopper
	5 times	E-OLM	Motor overloaded, I * t switching off	Check drive /motor/ventilation
	6 times	E-OLI	Inverter overloaded, I * t switching off	Check drive/ventilation
	7 times	E-OTM	Motor temperature	Motor overloaded, check installation conditions too high*
	8 times	E-OTI	Inverter temperature too high installation conditions	Inverter overloaded, check
	9 times	E-EEP	Error in EE-PROM	Switch off at mains and switch on again (Reset)

*only possible with the PTC or PT1 designs

Acknowledge error by pressing stop/return key for at least 3 sec. or with digital signal as described under 75-OPT1 (Chapter 6).

Support:

If contrary to expectations, you should have difficulties when starting up the frequency inverter, we are only glad to be of assistance with practical help and advice. You can reach our trained technicians as follows:

Address: Lust Antriebstechnik GmbH
Gewerbestraße 5-9
D-35633 Lahnau

Phone: + 49 64 41 966 111
Fax: + 49 64 41 966 137

3.4 Motor/inverter-overload protection (I * t monitoring)

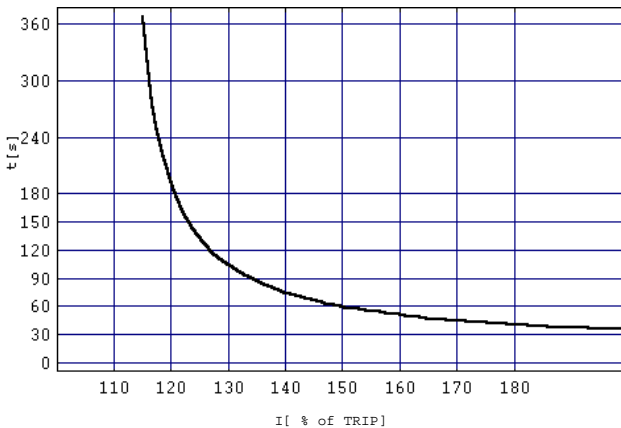
The I*t monitoring provides electronic motor protection and inverter protection against high thermal loading. The trigger characteristic can be taken from the diagram. The details relate to an output frequency of 50 Hz. It should be noted that with continuous operation with frequencies < 40 Hz the motor requires forced ventilation.

Rule of thumb:

An overload phase of 1 min. is possible within a margin of 10 min.s with a DC current of $I = 1,5 * I_N$ (150% overload)

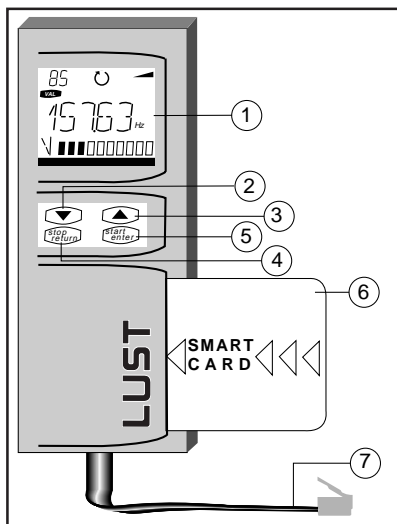


Diagram:



4 Operating the control unit KEYPAD KP100*

4.1 Layout plan



Key

Item	Designation	Function
1	LCD display	140 segments, backlit in green/red
2	Arrow key downwards	Back movement (scrolling) within the menu structure
3	Arrow key upwards	Forward movement (scrolling) within the menu structure
4	Stop/return key	Stop (Menu CTRL), interrupt or quit selected menu
5	Start/enter key	Starting (Menu CTRL), confirming or selecting menu
6	SMARTCARD	Chip cards-data memory, storing the device setting
7	Connecting cable	Maximum length 0.30 m

Mechanics

Dimensions	WxHxD	mm	62x158x21
Weight	-	g	100
Type of protection	-	-	VBG4, IP20
Ambient temperature	T	°C	0...40

* Accessories

4.2 In general

4.2.1 Menu branches

Once the mains is switched on, the device carries out a self-test (Display backlit in red).

The **VF1000** concludes this by jumping directly to the current value of the output frequency (Display backlit in green).

The menu branch VAL is active. When the stop/return key is pressed then the display changes to menu and opens the selection of further menu branches.

VAL	= Displays actual values
PARA	= Change parameter setting (parameterizing).
CTRL	= Motor control via KEYPAD
CARD	= Load/save device setting with the SMARTCARD



4.2.2 Key functions

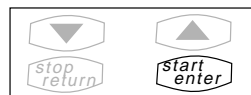
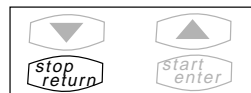
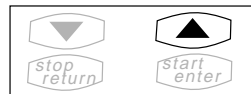
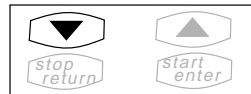
The arrow keys enable the selection of menu branches and enable their modification.

Pressed once they cause a jump to the next menu branch or parameter or the smallest possible alteration of a parameter value.

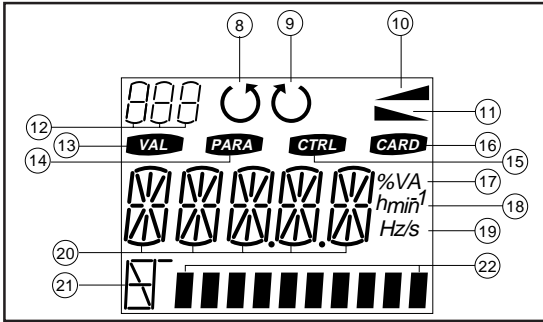
If a key is kept pressed down, it results in automatic run through (scrolling) which is stopped when the key is released.

With the stop/return-key, the menu branches are quit or parameter alterations are interrupted (old value is retained).

With the start/enter-key, menu branches or parameters are called up and changes are saved.



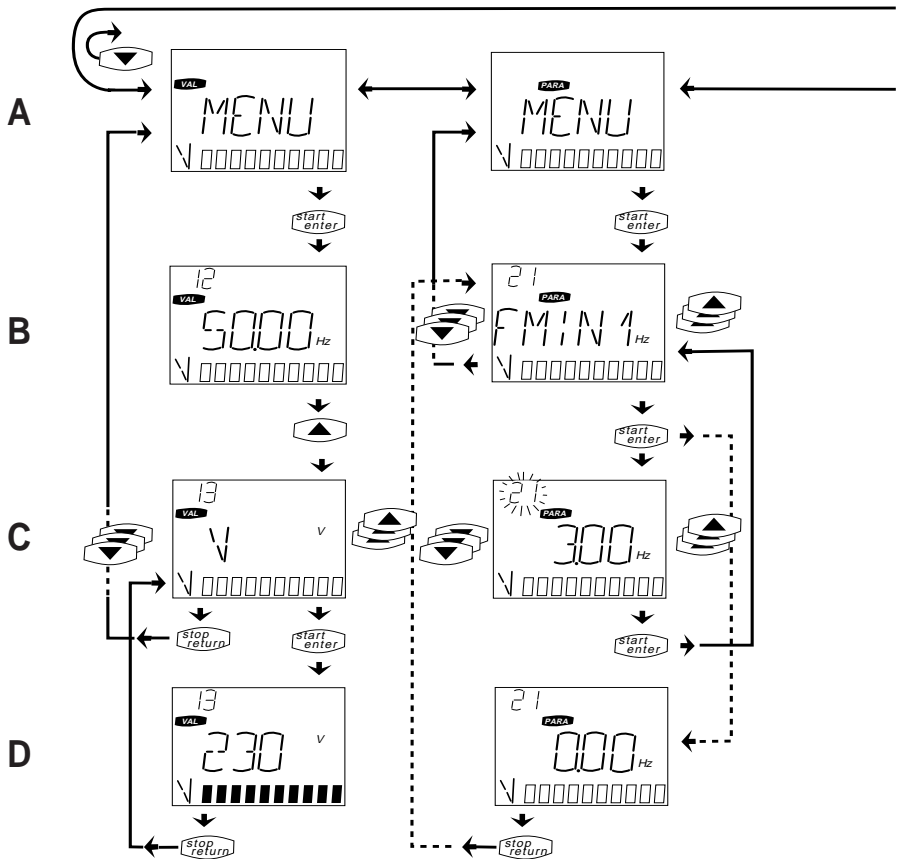
4.2.3 LCD- display



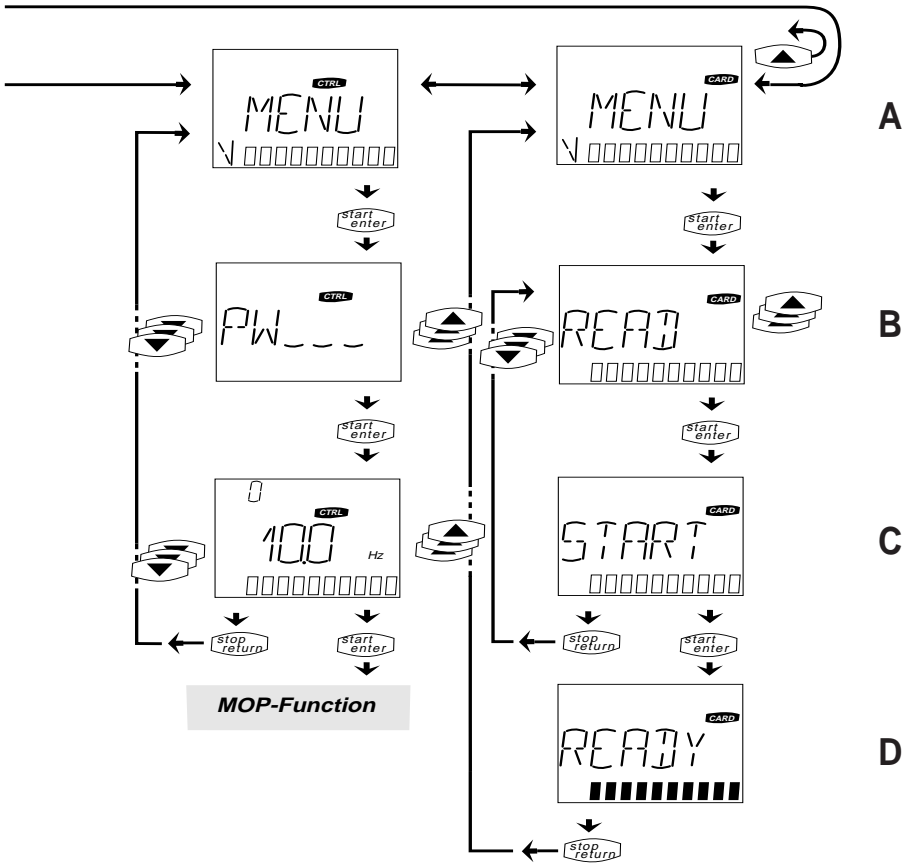
Item	Designation	Function
8	Counter-clockwise rotation	Control display for output rot. field, counter-clockwise active
9	Clockwise rotation	Control display for output rot. field, clockwise active
10	Acceleration ramp	Control display, during acceleration active
11	Braking ramp	Control display, active during braking
12	3 figure numerical display	7 segment display for actual values, Parameter No.
13	VAL menu	Shows actual values, e.g. frequency, voltage, current
14	PARA menu	Changing parameter setting
15	CTRL menu	Controlling motor via KEYPAD
16	CARD menu	Loading/saving device setting with the SMARTCARD
17	Phys. unit at item 20	shows %, V, A, VA with automatic assignment
18	Phys. unit at item 20	displays h, min ⁻¹ with automatic assignment
19	Phys. unit at item 20	displays Hz, s, Hz/s with automatic assignment
20	5 figure numerical display	15 segment display for parameter names and values
21	Bar graph designation	displays formula letters or physical unit for item 22
22	10 figure bar graph display	shows parameter values, frequency, voltage, apparent or effective current

4.3 Menu structure

4.3.1 Overview



A	Menu VAL (actual values) selected	Menu PARA selected
B	Display actual value, change with arrow key to next actual value parameter	Select parameters, e.g. FMIN1
C		Change parameter setting in offline mode (inverter stop)
D	Scan new actual value	Read parameter setting in online-mode (inverter start)



A Menu CTRL (Motor control via KEYPAD) selected Load/save Menu device setting (GE) with the SMARTCARD (SC)

Enter pass word
Factory setting = 573

READ = GE from SC load
WRITE = GE to SC save
LOCK = SC write protect
UNLCK = cancel write protect

B

C Frequency set value (KEYPAD) preset e.g. 10 Hz

selected with start/enter-key
Start function

D Activation of the MOP function (see next page)

Function ended error-free

4.3.2 MOP function with KeyPAD KP100

Once pass word is confirmed the control terminal is blocked. Preset frequency reference (KeyPAD) is e.g. 10 Hz. Start inverter by pressing the start/enter-key.

Actual value (small display) and clockwise rotation are additionally displayed.

Raise the speed reference to 50 Hz for example with the arrow key.

Inverter follows the increase with acceleration ramp.

Reduce speed reference with arrow keys.

Inverter follows the reduction with the braking ramp. With < 0.0 Hz the inverter changes the direction of the rotary field.

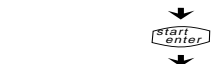
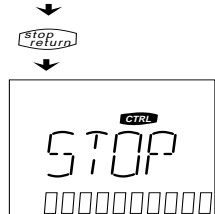
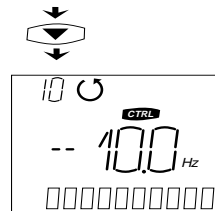
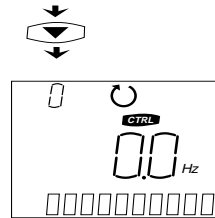
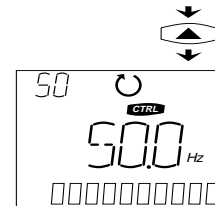
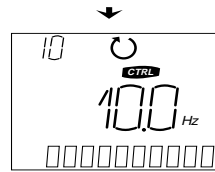
Increase speed reference (counter-clockwise) to 10 Hz for example.

In addition sign (--) indicates counter-clockwise.

Press stop/return-key, inverter brakes the motor to stand still.

The MOP function is reactivated with the start/enter-key.

from Overview
CTRL-Menu



to overview
CTRL-Menu

5 Parameter list

5.1 Operating level 1

Abbrev.	Name	Unit	Display range	Page	Factory setting	Customer
<i>Actual values</i>						
10-G	Scaled frequency	-	0 to 65535	6-5		
12-F	Output frequency	Hz	0.0 to 999.0	6-5		
13-U	Output voltage	V	0 to 460	6-6		
14-IS	Apparent current	A	0.0 to 52.0	6-6		
15-IW	Effective current	A	0.0 to 52.0	6-6		
16-PW	Effective power	W	0 to 22000	6-6		
17-UZK	DC-link voltage	VDC	0 to 900	6-6		
18-TIME	Switch-on dura. from reset	h	0.0 to 960.0	6-6		
19-TOP	Operating hours	h	0 to 60000	6-6		
<i>Device data</i>						
91-TYPE	Inverter type	-	15 types possible	6-21		
92-REV	Software version	-	-	6-21	see 2nd cover page	
95-ERR1	Last error	-	0-0.0 to 9-1.5 11-0.0 to 11-1.5	6-22		
Abbrev.	Name	Unit	Setting range	Page	Factory setting	Customer
1-MODE	Operating mode	-	0 to 3	6-1	1	
<i>Frequencies</i>						
20-FF2-1	Fixed frequency 2	Hz	0.0 to 999.0	6-7	3	
21-FMIN1	Minimum frequency	Hz	0.0 to 999.0	6-7	0	
22-FMAX1	Maximum frequency	Hz	4.0 to 999.0	6-7	50	
23-FF3	Fixed frequency 3	Hz	0.0 to 999.0	6-7	15	
24-FF4	Fixed frequency 4	Hz	0.0 to 999.0	6-7	30	
25-FF5	Comparative freq. S2OUT	Hz	0.0 to 999.0	6-7	3	
<i>Ramps</i>						
32-RACC1	Acceleration ramp 1	Hz/s	0.1 to 999.0	6-9	20	
33-RDEC1	Delay ramp 1	Hz/s	0.1 to 999.0	6-9	20	
36-RSTOP	STOP-delay ramp	Hz/s	0.0 to 999.0	6-9	0	
<i>Characteristics</i>						
41-V/FC	V/F characteristics selector	-	1 and 4	6-10	1	
42-VB1	Start voltage (Boost 1)	%	0.0 to 25.0	6-10	8	
43-FN1	Frequency rated point	Hz	15.0 to 960.0	6-10	50/60**	
44-VN1	Voltage rated point	V	43%...119% U _{Rated}	6-10	*	

*Dependent on inverter type, **Factory setting B

5.2 Operating level 2

Abbrev.	Name	Unit	Setting range	Page	Factory setting	Customer
<i>Reference input</i>						
4-FSSEL	Frequency ref. selector	-	0 to 23	6-1	0	
<i>Actual values</i>						
9-BARG	Bar graph assignment	-	6 Actual values	6-5	13-V	
<i>Frequencies</i>						
20-FF2-1	1st Fixed frequency 2	Hz	0.0 to 999.0	6-7	3	
21-FMIN1	1st Minimum frequency	Hz	0.0 to 999.0	6-7	0	
22-FMAX1	1st Maximum frequency	Hz	4.0 to 999.0	6-7	50	
23-FF3	Fixed frequency 3	Hz	0.0 to 999.0	6-7	15	
24-FF4	Fixed frequency 4	Hz	0.0 to 999.0	6-7	30	
25-FF5	Comparative frequency for S2OUT	Hz	0.0 to 999.0	6-7	3	
26-FF6	Control frequency (Data set)	Hz	0.0 to 999.0	6-7	0	
27-FF2-2	2nd Fixed frequency 2	Hz	0.0 to 999.0	6-7	5	
28-FMIN2	2nd Minimum frequency	Hz	0.0 to 999.0	6-7	0	
29-FMAX2	2nd Maximum frequency	Hz	4.0 to 999.0	6-7	50	
30-FF7	Fixed frequency FF7	Hz	0.0 to 999.0	6-7	50	
<i>Ramps</i>						
31-KSEL	Data set selector	-	0 to 3	6-8	0	
32-RACC1	1st acceleration ramp	Hz/s	0.1 to 999.0	6-9	20	
33-RDEC1	1st delay ramp	Hz/s	0.1 to 999.0	6-9	20	
34-RACC2	2nd acceleration ramp	Hz/s	0.1 to 999.0	6-9	80	
35-RDEC2	2nd delay ramp	Hz/s	0.1 to 999.0	6-9	80	
36-RSTOP	STOP-delay ramp	Hz/s	0.0 to 999.0	6-9	0	
<i>Characteristics</i>						
38-THTDC	Shut-down delay	s	0.0 to 120.0	6-10	0	
39-VHTDC	DC retaining voltage	%	1 to 25	6-10	4	
41-V/FC	V/F characteristics selector	-	1 and 4	6-10	1	
42-VB1	Starting voltage (Boost 1)	%	0.0 to 25.0	6-10	8	
43-FN1	Frequency-rated point 1	Hz	15.0 to 960.0	6-10	50/60**	
44-VN1	Voltage-rated point 1	V	43%...119% U _N	6-10	*	
45-VB2	Starting voltage (Boost 2)	%	0.0 to 25.0	6-10	*	
46-FN2	Frequency rated point 2	Hz	15.0 to 960.0	6-11	50/60**	
47-VN2	Voltage rated point 2	V	43%...119% U _N	6-11	*	

*Depends on inverter type, **Factory setting B



Note: When setting parameter 71-PROG to 1, all programmable parameters are set to the **factory setting** on confirmation of the parameter modification by pressing on the start/enter key (Message "wait").

Operating level 2 (Part 2)

Abbrev.	Name	Unit	Setting range	Page	Factory setting	Customer
<i>Special functions</i>						
48-IXR	I*R compensation	-	0 to 3	6-11	0	
49-SC	Slip compensation	-	0 to 2	6-13	0	
50-IN	Motor rated current	A	0 to 150% I _{Rated}	6-13	*	
51-COS	Power factor x100	%	0 to 100	6-13	82	
52-NN	Motor rated speed	UPM	0 to 24000	6-13	1400 (1700**)	
53-KIXR	Correction factor of the I*R compensation	-	0 to 30	6-14	*	
54-KSC	Correction factor of slip compensation	-	0.0 to 30.0	6-14	5	
55-ISEL	Current control-selector	-	0 to 2	6-14	0	
56-ILIM	Current limit	A	25 to 150% I _N	6-16	*	
57-FILIM	Min. sink frequency	Hz	0.0 to 999.0	6-16	15	
58-RILIM	Delay ramp for current control	Hz/s	0.1 to 999.0	6-16	50	
59-TRIP	I*t monitoring	A	25 to 150% I _N	6-16	*	
<i>Signal outputs</i>						
61-SOUTA	Frequency-/analog-output	-	0 to 14	6-17	9	
62-S1OUT	Output 1 digital	-	0 to 10	6-18	10	
63-S2OUT	Output 2 digital	-	0 to 10	6-18	7	
67-FST	Filter time constants	-	0 to 4	6-18	2	
69-KOUTA	SOUTA scaling	%	0 to 200	6-19	100	
<i>Program -functions</i>						
71-PROG	Special programs	-	0 to 4	6-19	0	
72-STRT	Start options	-	0 to 7	6-19	0	
74-PWM	Modulation frequency	-	0 to 2	6-20	0	
75-OPT1	Option 1***	-	0, 2 or 4	6-20	0	
86-KG	Scaling factor for 10-G	-	0 to 200	6-21	0	
87-DISP	Saved long-term Actual value display	-	All display parameters	6-21	12-F	
88-PSW1	Pass word 1 <PARA>	-	0.0 to 999.0	6-21	0	
89-PSW2	Pass word 2 <CTRL>	-	0.0 to 999.0	6-21	573	
94-MAXF	Absolute max. frequency	Hz	4.0 to 999.0	6-22	0	

*Depends on inverter type, **Factory setting B (see 5-4)

***Caution: This parameter can only be modified in operating mode 01-MODE = 3.

Note: I_N => device rated current (see type plate)
 U_N => device rated voltage (see type plate)



5.3 Inverter-type dependent and nationally-related parameters

Abbrev.	Page	Name	Unit	WE-A	WE-B	Inverter type
44-VN1	6-10	Voltage rated point 1	V	230	230	VF1205M...VF1207M
44-VN1	6-10	Voltage rated point 1	V	400	460	VF1404M...VF1410M
47-VN2	6-11	Voltage rated point 2	V	230	230	VF1203M...VF1207M
47-VN2	6-11	Voltage rated point 2	V	400	460	VF1404M...VF1410M
50-IN	6-13	Motor rated current,	A	4.5	4.5	VF1205M
56-ILIM	6-16	Current limit,	A	6.2	6.2	VF1207M
59-TRIP	6-16	I x t monitoring	A	3.5	3.4	VF1404M
			A	5.4	4.8	VF1406M
			A	7.1	6.3	VF1408M
			A	8.9	7.7	VF1410M
53-KIXR	6-14	Corr. factor I*R comp.	-	7	7	VF1205M
53-KIXR	6-14	Corr. factor I*R comp.	-	4	4	VF1207M
53-KIXR	6-14	Corr. factor I*R comp.	-	18	18	VF1404M
53-KIXR	6-14	Corr. factor I*R comp.	-	12	12	VF1406M
53-KIXR	6-14	Corr. factor I*R comp.	-	8	8	VF1408M
53-KIXR	6-14	Corr. factor I*R comp.	-	8	8	VF1410M
54-KSC	6-14	Corr. factor slip comp.	%	6.7	6.7	VF1205M
54-KSC	6-14	Corr. factor slip comp.	%	6	6	VF1207M
54-KSC	6-14	Corr. factor slip comp.	%	6	6	VF1404M
54-KSC	6-14	Corr. factor slip comp.	%	5.3	5.3	VF1406M
54-KSC	6-14	Corr. factor slip comp.	%	5.3	5.3	VF1408M, VF1410M

Solely nationally related parameters					
22-FMAX1	6-7	Maximum frequency 1	Hz	50	60
29-FMAX2	6-7	Maximum frequency 2	Hz	50	60
43-FN1	6-10	Frequency rated point 1	Hz	50	60
46-FN2	6-11	Frequency rated point 2	Hz	50	60
52-NN	6-13	Rated speed	UPM	1390	1710



Factory setting (FS):

The factory setting can be adjusted with the KEYPAD in the PARA menu. To this end parameter 71-PROG must be set to 1 (WE-A e.g. for Europe) or 71-PROG to 4 (WE-B e.g. for USA).

6 Parameter description

01-MODE Operating mode [Decimal]

MODE determines the control options for the inverter and defines the effective operating level e.g. for the KEYPAD KP100.

The parameters are allocated in 3 levels.

In Level 1, the most important parameters for commissioning are to be found.

Level 2 enables in addition to the alteration of the parameters contained in Level 1, access to further parameters as well as special and control functions, such as data set changeover or programming the control outputs for example.

Level 3 is reserved for interface parameters (SIO mode) and special parameters (further information about this can be found in the information booklet "Parameter description - Total range").

01-MODE = 1 -> Operating level 1 Commissioning level
01-MODE = 2 -> Operating level 2 Operating and control function
01-MODE = 3 -> Operating level 3 Interfaces and special param.
01-MODE = 0 -> Operating level 0 Only SIO-mode

6.1 Reference input

04-FSSEL Frequency reference selector

Offers the selection between various types of reference (analog, frequency or PWM-signal) and their origin (KEYPAD, SIO,...).

04-FSSEL	Function
0	Analog input active, adaption via J1 ... J6
1/2	Not active
3	FSIN as frequency input 0 to 1 kHz active
4	FSIN as frequency input 0 to 10 kHz active
5	FSIN as PWM input 20 to 100% active
6	FSIN as PWM input 0 to 100% active
7	FSIN not active, reference via KP100 (CTRL- menu)
8	Reference via interface
9 to 16	Reference input see following
17 to 22	Correction of the analog reference via S1IND/S2IND (MOP-function active)
23	Inverted analog input, 10 V = FMIN, 0 V = FMAX

Reference input block diagram

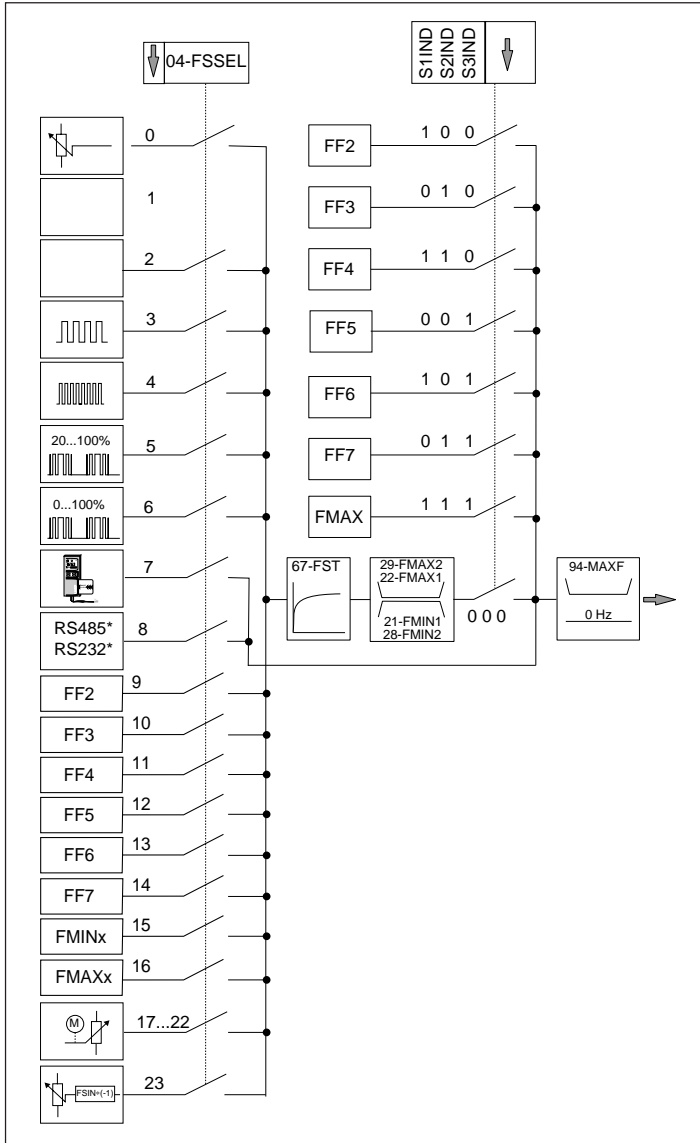


Fig. 6-1

* Designs see Chapter 2.4.7

04-FSSEL = 0

FSIN is active as analog input. The adaption to 0(2) ... 10 V or 0 (4) ... 20 mA is via jumper rail J1 ... J6.

04-FSSEL = 1, 2

Without function.

04-FSSEL = 3

FSIN functions as frequency input.

FMIN = 0 Hz FMAX = 1 kHz, adaption via jumper rail J1 ... J6.

04-FSSEL = 4

FSIN functions as frequency input.

FMIN = 0 Hz FMAX = 10 kHz, adaption via jumper rail J1 ... J6.

04-FSSEL = 5

FSIN operates as clock input for impulse width modulated signal.

FMIN = 20% PWM FMAX = 100% PWM (see Fig. 6-2). The basic signal of the PWM signal must be 0.9 ... 8 kHz, adaption via J1 ... J6.

04-FSSEL = 6

FSIN operates as clock input for impulse width modulated signals.

FMIN = 0% PWM FMAX = 100% PWM (see Fig. 6-2). The basic frequency of the PWM signal must be 0.9 ... 8 kHz, adaption via jumper rail J1 ... J6..

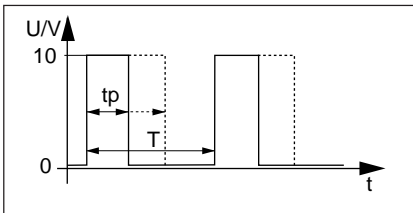


Fig. 6-2

$$FSIN[Hz] = \frac{FMAX - FMIN}{(1 - A)} \cdot (K - A) + FMIN$$

$$K = \frac{tp}{T}$$

04-FSSEL	Adjustment range	A
5	0 ...100% PWM	0
6	20...100% PWM	0,2

04-FSSEL = 7

FSIN is not active. When starting the MOP function in the CTRL-menu of the **KEYPADS**, 04-FSSEL = 7 is set automatically, and reset to 04-FSSEL = 0 on quitting.

04-FSSEL = 8

FSIN input and **KEYPAD** input are not active. Reference can only be entered externally via interface.

04-FSSEL = 9...16

FSIN input and **KEYPAD** input are not active. Function see Fig. S.6-2.

04-FSSEL = 17¹⁾

FSIN input active (base reference). The reference can be continuously raised with **S1IND** and continuously lowered with **S2IND** (Reference offset with MOP function).

04-FSSEL = 18¹⁾

Has same function as 04-FSSEL = 17 with following supplement:
With simultaneous activation of **S1IND** and **S2IND**, the reference is reset to the base reference (Reference offset = 0).

04-FSSEL = 19¹⁾

Has the same function as 04-FSSEL = 17 with following supplement:
With preset reference offset and mains off, this offset is saved until it is modified or reset via **S1IND** and **S2IND**.

04-FSSEL = 20¹⁾

Has the same function as 04-FSSEL = 18 and 19

04-FSSEL = 21¹⁾

Has the same function as 04-FSSEL = 17 with following supplement:
When the inverter is stopped, the reference is reset to the base reference (Reference offset = 0).

04-FSSEL = 22¹⁾

Has the same function as 04-FSSEL = 18 and 21

04-FSSEL = 23¹⁾

The FSIN input functions as inverted analog input.
10 V = FMIN 0V = FMAX

1) see description of the MOP function with **S1IND/S2IND** in Chapter 2.4.5

6.2 Actual values

09-BARG Bar graph display [Decimal]

The following parameters can be depicted in the bar graph display.

09-BARG	Function
STAT	Depiction as bit model, see Fig. 6-3
12-F	Output frequency as analog bar, Des. < F >
13-V	Output voltage, Des. < V > (Factory setting)
14-IS	Apparent current as analog bar, Des. < I >
15-IW	Effective current as analog bar, Des. < I >
SIN	Depiction as bit model, see Fig. 6-3

09-BARG = 11-STAT

A -> generating current

B -> current limiting value reached

$$I_s > 110\% I_N$$

C -> 12-F > 25-FF5

D -> reference reached

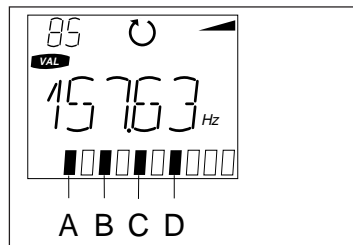


Fig. 6-3

09-BARG = 66-SIN

A -> S2OUT active

B -> S1OUT active

C -> S2IND active

D -> S1IND active

10-G Scaled frequency

Displays the actual output frequency 12-F multiplied with the factor from parameter 86-KG, no decimal fractions or physical units being displayed.

$$(10_G) = (12_F) * (86_KG)$$

12-F Output frequency [Hz]

Displays the actual output frequency. After error shut-down, the actual value existing before shut down is saved (Hold-Function).

13-V Output voltage [V]

Displays the actual output voltage. The output voltage is kept constant independently of the DC-link voltage (DC-link compensation), if a drive reserve is available. After a error shut-down, the actual value existing immediately before shut-down is saved (Hold-Function).

14-IS Phase current [A]

Displays the actual apparent phase current. After an error shut-down, the actual value existing immediately before shut-down is saved (Hold-Function).

15-IW Effective current [A]

Displays the actual effective phase current. After an error shut-down, the actual value existing immediately before shut-down is saved (Hold-Function).

16-PW Effective power [W]

Displays the effective power from the inverter.

$$(16_PW) = \sqrt{3} * (15_IW) * (13_V)$$

17-VZK DC-link voltage [VDC]

Displays the actual DC-link voltage. After a error shut-down, the actual value existing immediately before shut-down is saved (Hold-Function).

18-TIME Switch-on duration from reset [0.1 hour]

Displays the switch-on duration since last reconnection to mains.

19-TOP Running time [hours]

Displays the total running time. The maximum value is 60000 hours. Once this level is reached, there is no further increase.

6.3 Frequencies

20-FF2-1 1st fixed frequency FF2 [Hz]

Parameter of the 1st data set.

As reference can be selected via $S1IND = 1$, $S2IND = 0$ and $S3IND = 0$

21-FMIN1 Minimum frequency for analog reference input [Hz]

Parameter of the 1st data set. Reference input $FSIN = 0$ (2) V or 0 (4) mA corresponds to an output frequency of FMIN.

22-FMAX1 Maximum frequency for analog reference input [Hz]

Parameter of the 1st data set. Reference input $FSIN = 10$ V or 20 mA corresponds to an output frequency of FMAX.

23-FF3 Fixed frequency FF3 [Hz]

As reference can be selected via $S1IND = 0$, $S2IND = 1$ and $S3IND = 0$

24-FF4 Fixed frequency FF4 [Hz]

As reference can be selected via $S1IND = 1$, $S2IND = 1$ and $S3IND = 0$

25-FF5 Fixed frequency FF5 [Hz]

Frequency thresholds for programmable outputs $S1OUT$, $S2OUT$ and $S3OUT$. (also see 62-S1OUT 63-S2OUT, 64-S3OUT)

As reference can be selected via $S1IND = 0$, $S2IND = 0$ and $S3IND = 1$

26-FF6 Fixed frequency FF6 [Hz]

Frequency threshold for data set changeover at 31-KSEL = 1

As reference can be selected via $S1IND = 1$, $S2IND = 0$ and $S3IND = 1$

27-FF2-2 2nd fixed frequency FF2 [Hz]

Parameter of the 2nd data set

As reference can be selected via $S1IND = 1$, $S2IND = 0$ and $S3IND = 0$

28-FMIN2 Minimum frequency for analog reference input [Hz]

Parameter of the 2nd data set (see also 21-FMIN1).

29-FMAX2 Maximum frequency for analog reference input [Hz]

Parameter of the 2nd data set (see also 22-FMAX1).

30-FF7 Fixed frequency 7 [Hz]

As reference can be selected via $S1IND = 0$, $S2IND = 1$ and $S3IND = 1$

Fixed frequency selection for digital inputs

S1IND	S2IND	S3IND	Speed reference	Factory setting
1	0	0	20-FF2-1 [27-FF2-2]	FF2 = 5 Hz [3 Hz]
0	1	0	23-FF3	FF3 = 15 Hz
1	1	0	24-FF4	FF4 = 30 Hz
0	0	1	25-FF5	FF5 = 3 Hz
1	0	1	26-FF6	FF6 = 0 Hz
0	1	1	30-FF7	FF7 = 50 Hz

6.4 Ramps

31-KSEL Data set selector

The data set selector determines the control factors for data changeover. Possible control factors for data changeover:

31-KSEL	Function	Example of application
0	Data set changeover inactive, data set 1 remains	Standard, factory setting
1	Changeover to 2nd data set if: 12-F > 26-FF6	Heavy load start-up
2	Changing over data sets with S2IND	Varying operation from 2 motors to 1 inverter
3	Changing over to 2nd data set with counter-clockwise (STL active) dependent load	Drive with rotation direction

Two data sets with following parameters are available.

Parameter	Data set 1	Data set 2
Minimum frequency	21-FMIN1	28-FMIN2
Maximum frequency	22-FMAX1	29-FMAX2
Fixed frequency 2	20-FF2-1	27-FF2-2
Acceleration ramp	32-RACC1	34-RACC2
Braking ramp	33-RDEC1	35-RDEC2
Voltage increase	42-VB1	45-VB2
Rated voltage	44-VN1	47-VN2
Rated frequency	43-FN1	46-FN2

32-RACC1 Start-up ramp [Hz/s]

Parameter of the 1st data set, see Fig. 6-4.

33-RDEC1 Deceleration ramp [Hz/s]

Parameter of the 1st data set, see Fig. 6-4.

34-RACC2 Start-up ramp [Hz/s]

Parameter of the 2nd data set, see Fig. 6-4.

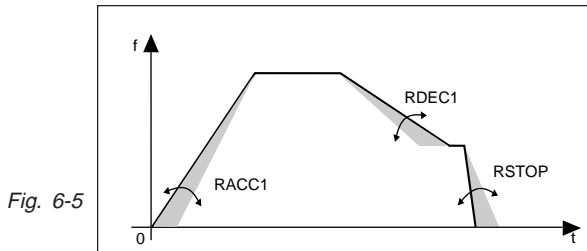
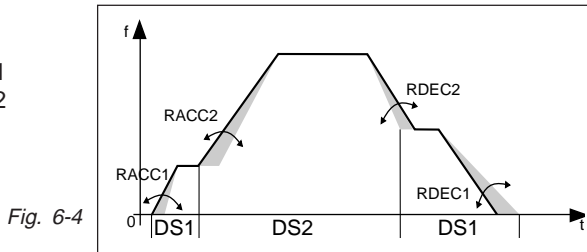
35-RDEC2 Deceleration ramp [Hz/s]

Parameter of the 2nd data set, see Fig. 6-4.

36-RSTOP Stop ramp [Hz/s]

With activated stop ramp ($36\text{-RSTOP} > 0$) the inverter after setting of the control inputs STR and STL to 0, carries out a deceleration ramp with a gradient of 36-RSTOP, see Fig. 6-5. Subsequent maintenance of the DC current is possible with $38\text{-THTDC} > 0$. With $36\text{-RSTOP} = 0$ the motor comes to a halt by itself, if STL and STR are set to 0.

DS1 = Data set 1
DS2 = Data set 2



6.5 Characteristics

38-THTDC DC hold- shut-down delay [s]

The DC hold becomes active once the shut-down limit ($F < 0.5$ Hz) is exceeded. It is unimportant whether braking is with 33-RDEC1 or with 36-RSTOP. The hold time can be set up to 120 s. Permanent hold is not possible.

39-VHTDC DC hold voltage level [%]

The output voltage for DC hold can be set with parameter 39-VHTDC in % of the device rated voltage (max. 25 %).

41-V/FC Characteristics selector [Decimal]

41-V/FC = 1 -> linear voltage-frequency characteristics
4 -> quadratic voltage-frequency characteristics

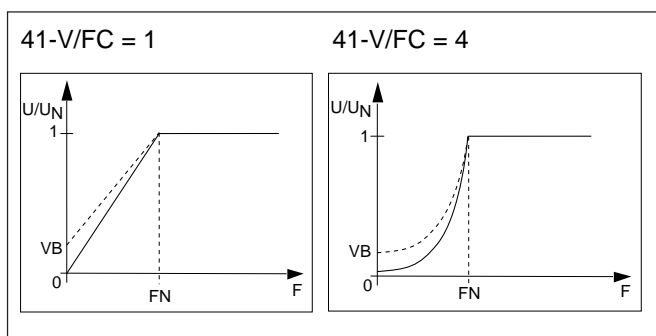


Fig. 6-6

42-VB1 Voltage increase [%]

Parameter of the 1st data set. Voltage at frequency of 0 Hz. Raising the torque in the start-up range. See also Fig. 6-6.

43-FN1 Rated frequency [Hz]

Parameter of the 1st data set. Frequency point, at which the inverter achieves the rated output voltage (setting from 44VN1). See also Fig. 6-6.

44-VN1 Rated voltage [V]

Parameter of the 1st data set. Input the voltage, which the inverter should have when it reaches 43-FN1. See also Fig. 6-6.

45-VB2 Voltage increase [%]

Parameter of the 2nd data set. See 42-VB1. See also Fig. 6-6.

46-FN2 Rated frequency [Hz]

Parameter of the 2nd data set. See 43-FN1. See also Fig. 6-6.

47-VN2 Rated voltage [V]

Parameter of the 2nd data set. See 44-VN1. See also Fig. 6-6.

6.6 Special functions

48-IXR Automatic load control (I*R-Compensation)

- 48-IXR = 0 -> I*R Compensation inactive
1 -> I*R Compensation active with 1st and 2nd data set
2 -> I*R Compensation only active with 1st data set
3 -> I*R Compensation only active with 2nd data set

Precondition for activation of the I*R compensation:

Motor data (Type plate) **50-IN**, **51-COS** and **52-NN** entered for the load characteristics.

The purpose of the I*R compensation is to produce a constant torque and reduced heating of the motor coil. This is achieved by transplacing the load characteristics as determined by the characteristics parameters, by an amount ΔU determined by the effective current.

See Fig. 6-7.

$$\Delta U = (I_W - I_N * \text{COS}) * K_{IXR}$$

I_W = 15-IW (Effective current)

I_N = 50-IN (Motor rated current)

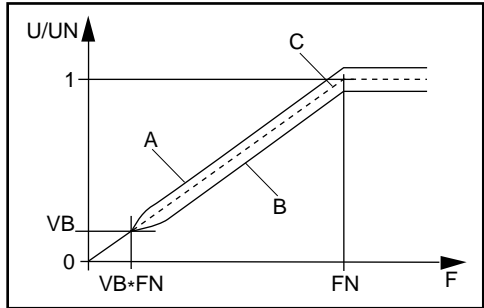
COS = 51-COS ($\cos\phi$ Motor)

KIXR = 53-KIXR (Correction factor)

The I*R compensation becomes effective from the frequency $V_B * F_N$. It is increased linearly: from 0 % at frequency $V_B * F_N$, to 100 % at frequency $2 * V_B * F_N$. Furthermore it is effective up to 100% (see Fig. 6-8).

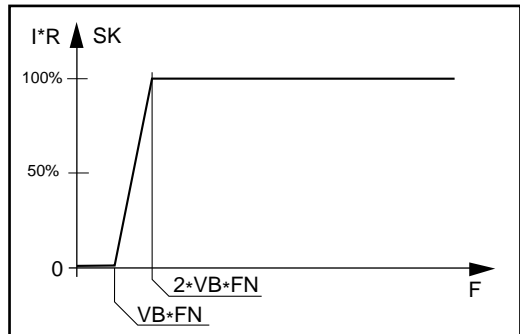
- A -> $IW >$ Rated current (Rated load)
- B -> $IW = 0$ (Idling)
- C -> Non-compensated characteristics

Fig. 6-7



- Ratio of the $I \cdot R$ -compensation ($I \cdot R$)
- Ratio of the slip compensation (SK)

Fig. 6-8



49-SC Slip compensation On/Off [Decimal]

- 49-SC = 0 -> Slip compensation inactive
1 -> Slip compensation with 1st and 2nd data set active
2 -> Slip compensation only active with 2nd data set

Precondition for activation of the slip compensation:
Enter motor data (Type plate) **50-IN**, **51-COS** and **52-NN**.

The purpose of the slip compensation is to maintain the speed constant independently of load. In the basic setting range (0 to FN), a frequency correction ΔF proportional to the effective current (15-IW) is added to the actual frequency (12-F).

This ΔF is still corrected by the factor F/FN in the field weak range. The frequency increase so calculated is however not displayed in the parameter 12-F.

The slip compensation becomes effective at characteristics point [VB * FN]. It increases linearly from 0 % at frequency [VB * FN], up to 100 % at frequency [2 * VB * FN]. Furthermore it is effective up to 100 % (See Fig. 6-8).

The entry of the frequency is only limited by parameter 94-MAXF. The frequency correction is determined from the formula:

In the base range

$$\Delta F = \frac{KSC * IW}{INU} * FN$$

IW = 15-IW (Effective current)

INU = Inverter rated current

FN = Param. 43-FN1 (Rated frequency)

KSC = Param. 54-KSC (Correction factor)

F = Param. 12-F (Act. frequency)
In the field weak range

$$\Delta F = \frac{KSC * IW}{INU} * \frac{F}{FN} * FN$$

50-IN Motor rated current [A]

Motor rated current from motor type plate.
Application with I*R and slip compensation.

51-COS Rated $\cos\phi$ [%]

$\cos\phi$ from motor type plate (to be entered in %).
Application with I*R and slip compensation.

52-NN Rated speed [1/min]

Rated speed from motor type plate.
Application with I*R and slip compensation.

53-KIXR Correction factor, I * R compensation

The correction factor KIXR corresponds to the resistance measured between two cables. The correction factor can either be entered or measured by the inverter.

→ The measurement is started, if 48-IXR = 1 and 53-KIXR = 0.

The inverter then issues a max. of 1/16 of the device voltage for approx. 2 s or permits the flow of a max. current of 50-IN (entered motor rated current). The measured value is automatically stored under 53-KIXR.



Caution:

The motor may turn slowly during the measurement.

54-KSC Slip compensation, correction factor [%]

The correction factor 54-KSC is just like the motor rated slip scaled to the device rated current.

$$KSC = \frac{N_{SYN} - NN}{N_{SYN}} * \frac{I_{NU}}{IN * COS} * 100 [\%]$$

N_{SYN} = Synchron. speed
 NN = 52-NN (Motor rated speed)
 I_{NU} = Inverter rated current
 IN = 50-IN (Motor rated current)
 COS = 51-COS (cos ϕ)

The correction factor can be either entered or calculated by the inverter. The calculation is started, when 49-SC = 1 and 54-KSC = 0. The synchronous speed for the calculation is determined from the rated frequency 43-FN1. The calculated value is automatically stored under 54-KSC.

55-ISEL Actual control selector [Decimal]

The actual control selector determines the type of current limit regulation. The controlled dimension is the apparent phase current 14-IS.

55-ISEL	Function
0	Current limit control inactive
1	Acceleration / braking ramp current controlled, return of the ramp function with $I > 125\%$ ILIM
2	Acceleration / braking ramp current controlled, ramp stop at $I > 125\%$ ILIM
3	Current injection*
4	As setting 1, but with current injection*
5	As setting 2, but with current injection*

*More detailed information on request

Current controlled start-up (55-ISEL = 1)

Once the inverter is started, the motor is accelerated with 32-RACC1. On reaching the current limit of 75% of 56-ILIM the acceleration is slowed down. If the phase current 14-IS increases further and exceeds 100% of 56-ILIM, the motor is not further accelerated. When the current limit of 125% of 56-ILIM is exceeded, the rotary field frequency input with FSIN is reduced with the ramp 58-RILIM lowering frequency 57-FILIM. When the phase current subsides to below 100% of 56-ILIM, the inverter accelerates the motor further with the ramp 32-RACC1, the same applying for braking. The frequency can then be raised up to 94-MAXF, see Fig. 6-9.

Current controlled start-up (55-ISEL = 2)

Operation as above with following difference:

Once the current limit of 125% of 56-ILIM has been exceeded, the ramp 32-RACC1 does not accelerate further. There are no further frequency reductions.

Current controlled start-up (55-ISEL = 3/4/5)

More detailed information available on request.

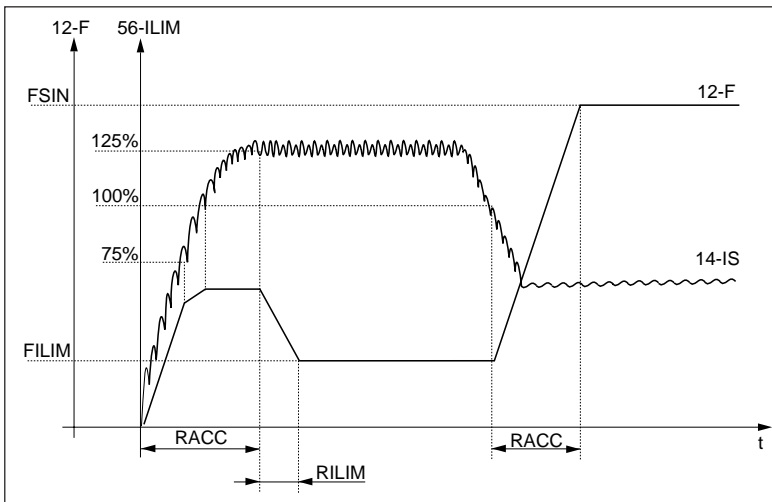


Fig. 6-9 (Current controlled start-up)

56-ILIM Current limit value [A]

See 55-ISEL and diagram.

57-FILIM Minimum reduction frequency for current control [Hz]

See 55-ISEL and diagram.

58-RILIM Ramp for current control [Hz/s]

See 55-ISEL and diagram.

59-TRIP I * t Monitoring (Motor), trigger current [A]

With the parameter 59-TRIP, the I*t trigger current is set. Once this current is exceeded there follows after a certain trigger time (see diagram) shut-down with the error message E-OLM.

Motor protection:

The setting of the I*t trigger current must be in accordance with the motor rated current. Thus even motors with smaller power outputs than the device rated power are sufficiently protected from overloading.

Independently from the parameter 59-TRIP, the inverter has a I*t monitoring (device) which corresponds to one setting 59-TRIP = device rated current and results in shut-down with error message E_OLI after approx.100 ms, with $I = 2 * I_N$.

Factory setting: 59-TRIP = I_N (Device rated current)

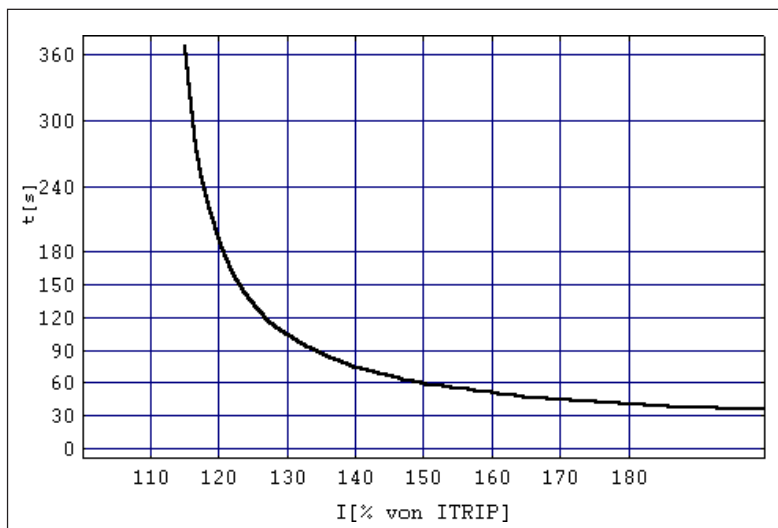


Fig. 6-10

6.7 Signal outputs

61-SOUTA Analog/frequency output

61-SOUTA	Function
0/2/7/8/10/11	Outputs not active $SOUTA = 0$, $SOUTF = 24V$
1	$SOUTA = 0...10V \gg 0 \dots FMAX$ proportional to the output frequency, $SOUTF = 24V$ (not active)
3	$FOUTF = 6\text{-fold output frequency}$, $SOUTA = 0$ (not active)
4 rated current,	$SOUTA = 0...10V \Rightarrow$ Apparent current scaled to 100% of the device $SOUTF = 24V$ (not active)
5	$SOUTA = 0...10V \Rightarrow$ Effective current scaled to 100% of the device rated current, $SOUTF = 24V$ (not active)
6 rated power,	$SOUTA = 0...10V \Rightarrow$ Effective power scaled to 100% of the device $SOUTF = 24V$ (not active)
9 WE	$SOUTA$ as 61-SOUTA= 1, $SOUTF = 6\text{-fold output frequency}$
12	$SOUTA$ as 61-SOUTA= 4, $SOUTF = 6\text{-fold output frequency}$
13	$SOUTA$ as 61-SOUTA= 5, $SOUTF = 6\text{-fold output frequency}$
14	$SOUTA$ as 61-SOUTA= 6, $SOUTF = 6\text{-fold output frequency}$

Comment:

If the outputs $SOUTA$ and $SOUTF$ simultaneously in use (Param. 61-SOUTA = 9,12,13,14), the quality of the signals is poorer (Basic frequency = 60Hz). If output $SOUTA$ is in use alone (Param. 61-SOUTA = 1,4,5,6), the quality of the signals is better (Basic frequency = 1.6 kHz).



**62-S1OUT Programmable control output S1OUT [Decimal]
63-S2OUT Programmable control output S2OUT [Decimal]**

62-S1OUT 63-S2OUT	Function
0,9	Without function, outputs S_OUT = 0
1	active, as soon as inverter on mains and no error existing
2	active, as long as motor excited
3	active, as long as counter-clockwise speed > 0 or DC hold active
4	active, as long as clockwise speed > 0 or DC hold active
5	active, as long as rotary field frequency 12-F = 0
6	active as soon as reference reached
7	active, if rotary field frequency 12-F > 25-FF5
8	active, if apparent current 14-IS > 110%, 59-TRIP current limit reached
10	active, after an error shut-down

Factory setting: 62-S1OUT ->10, 63-S2OUT -> 1

6.8 Program functions

67-FST Filter time constants [Decimal]

Determines the filter time constants for analog reference input FSIN. (see also 04-FSSEL). Temporal performance as PT1-member (deceleration pass).

67-FST	Function
0	0 ms
1	8.2 ms
2	24.6 ms, factory setting
3	57.4 ms
4	123 ms

69-KOUTA Factor for analog output 61-SOUTA [Decimal]

This parameter enables the scaling of the analog output SOUTA.

When an analog signal is issued, the voltage is multiplied by the factor 69-KOUTA in accordance with the programming and limited to 15 V.

71-PROG Special programs [Decimal]

With 71-PROG, special programs can be activated. Possible special programs at present:

71-PROG	Function
0	No special program active
1	Reset to factory setting "A" e.g. Europe (according to design 71-PROG = 0)
2	changed significance of the control terminals STR = 0 -> clockwise, STL = 1 -> START STR = 1 -> counter-clockwise, STL = 0 -> STOP
4	as 1, however factory setting "B" e.g. USA

72-STRT Starting options [Decimal]

72-STRT	Function
0	No starting option active, factory setting
1	Autostart after mains on with STL or STR bypassed
2	Synchronisation to running motor
3	Autostart and synchronisation
4	Rotation direction block: counter-clockwise rotation blocked
5	Rotation direction block and autostart
6	Rotation direction block and synchronisation
7	Autostart, synchronisation, rotation direction block

Autostart 72-STRT = 1

If one of the start contacts STL or STR is bypassed and the reference input FSIN > 0.5 Hz, the inverter starts automatically once mains supply is reconnected.

Synchronisation 72-STRT = 2

Once the start contact is activated, the inverter first of all carries out a search procedure to determine the current motor speed. The search starts with the maximum frequency 22-FMAX1, meaning that the inverter is working super-synchronously, producing a positive effective current. The rotary field frequency is reduced until the effective current becomes negative. Hence the inverter is operating sub-synchronously. The inverter synchronises to the motor speed thus found with the appropriate rotary field frequency.

The synchronisation functions in both rotation directions.

Rotation direction block 72-STRT = 4

With this start option, rotation counter-clockwise with respect to the inverter is blocked in every case. This means that the counter-clockwise rotation direction can neither be activated by the control input STL nor by the CTRL menu.

74-PWM Switching frequency [Decimal]

Parameter 74-PWM determines the switching frequency of the final levels.

74-PWM	Switching frequency	suitable for	Factory setting
0	7.8 kHz	VF1205M to VF1410M	all VF1000M
1	15.6 kHz	VF1205M to VF1410M	
2	3.9 kHz	VF1205M to VF1410M	

75-OPT1 Options 1

With this parameter, the special functions for the error acknowledgement for example are possible.



Note: This parameter can only be set with 01-MODE = 3.

75-OPT1	Function
0 0 H	Without function
0 2 H	Error acknowledgement via S2IND
0 4 H	Error acknowledgement via STL or STR

86-KG Scaling factor for 10-G

The factor determines the value of the display parameter 10-G according to the formula:

$$(10_G) = (12_F) * (86_KG)$$

87-DISP Permanent display [Decimal]

Determines the parameter for the permanent display.
All parameters from the menu „VAL“ are possible.

88-PSW1 Pass word 1 [Decimal]

Determines the pass word for the parameterization menu <PARA>

89-PSW2 Pass word 2 [Decimal]

Determines the pass word for control via KEYPAD <CTRL>menu

91-TYPE Inverter type [Decimal]

Issues the type of the identified end level. All min-max values and factory settings of the voltage and current dimensions, which must be entered absolutely, depending for example from:

VF1207M - 44-VN1 = 230 V factory setting

VF1406M - 44-VN1 = 400 V factory setting

92-REV Software revision [Decimal]

States the installed software version (see 2nd cover page).

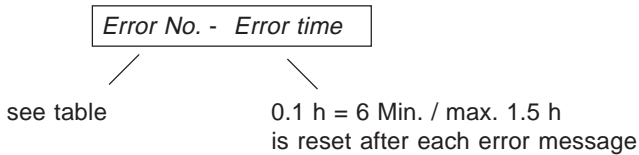
94-MAXF Absolute maximum frequency [Hz]

Is the maximum frequency which is produced by the inverter. The parameter is applied with frequency reference formation, current limit value regulation, slip compensation and synchronisation to running motor. Setting 0 signifies: The limiting of MAXF is switched off. Then only the limitation from 22-FMAX1 or 29-FMAX2 is still active.

95-ERR1 Error 1 [Decimal-0.1h]

Stores the last error message.

Representation:



Possible error messages:

No.	Significance
1-time	Error in computer component
2-time	Low voltage (no entry in 95-ERR1 ÷ 98-ERR4)
3-time	Excess current, short circuit or earthed after mains on
4-time	Excess voltage
5-time	I * t Motor
6-time	I * t Inverter
7-time	Excess temperature motor
8-time	Excess temperature inverter
9-time	Error in EEPROM

Acknowledge error by pressing stop/return-key for at least 3 sec. or with digital signal as described under 75-OPT1.

