



User Manual

Servo Drive & Motor

IS620P & ISMH Series

Pulse & Analog Reference

20 Bit Serial Encoder



Please Read This Important Information

Inovance Technology designs and manufactures the IS620P Series of Servo Drives for the industrial automation market and is committed to a policy of continuous product development and improvement.

The product is supplied with the latest version software and the contents of this manual are correct at the time of printing. If there is any doubt with regards to the software version or the manual contents, please contact Inovance Technology or the Authorized Distributor.

Inovance Technology accepts no liability for any consequences resulting from negligent or incorrect installation or parameter adjustment of the Servo Drive, including mismatching of the Servo Drive with the motor.

The Servo Drive is intended as an industrial automation component for professional incorporation into a complete machine or process system. It is the responsibility of the user or machine builder or installation contractor or electrical designer/engineer to take all necessary precautions to ensure that the system complies with current standards, and to provide any devices (including safety components), required to ensure the overall safety of the equipment and personnel.

If in doubt, please contact Inovance Technology or the Authorized Distributor.

Please read this manual before starting work on the Servo Drive. Only qualified personnel with relevant training and experience should be allowed to work on the Servo Drive as high voltages (including DC voltage) exists within the Servo Drive, even after power OFF. Strict adherence to this instruction is required to ensure a high level of safety. If in doubt, please consult with Inovance Technology or the Authorized Distributor.



Contents

Please Read This Important Information	1
Safety Information and Precautions	10
Chapter 1 Product Information	14
1.1 Servo Drive	14
1.1.1 Designation Rules and Nameplate	14
1.1.2 Components of Servo Drive	15
1.1.3 Specifications of Servo Drive	16
1.1.4 Specifications of Regenerative Resistor	21
1.2 Servo Motor	22
1.2.1 Designation Rules and Nameplate	22
1.2.2 Specifications of Servo Motor	23
1.3 Servo System Configuration	30
1.4 Matching Cables	31
1.4.1 Servo Motor Power Cable and Encoder Cable	31
1.4.2 Communication Cable	34
1.5 Servo System Wiring	34
Chapter 2 Installation	38
2.1 Installation of Servo Drive	38
2.1.1 Installation Location	38
2.1.2 Installation Environment	38
2.1.3 Installation Precautions	38
2.2 Installation of Servo Motor	40
2.2.1 Installation Location	40
2.2.2 Installation Environment	40
2.2.3 Installation Precautions	41
Chapter 3 Wiring	46
3.1 Wiring of Servo Drive Main Circuit	49
3.1.1 Main Circuit Terminals	49
3.1.2 Examples of Regenerative Resistor Wiring	51
3.1.3 Recommended Models and Specifications of Power Cables	52
3.1.4 Power Supply Wiring Example	55
3.1.5 Precautions for Main Circuit Wiring	58
3.1.6 Specifications of Main Circuit Peripheral Parts	59
3.2 Wiring of Motor Cables Between Servo Drive and Servo Motor	60
3.3 Wiring of Encoder Cables Between Servo Drive and Servo Motor	62
3.3.1 Connection of Serial Incremental Encoder	62
3.3.2 Installation of Absolute Encoder	65
3.4 Wiring to Control Signal Terminal Connector CN1	71

3.4.1	Position Reference Input Signals	73
3.4.2	AI Signals	82
3.4.3	DI/DO Signals	83
3.4.4	Encoder Frequency-Division Output Circuit.....	87
3.4.5	Wiring of the Motor Brake.....	89
3.5	Wiring to Communication Signal Terminal Connectors CN3/CN4.....	91
3.5.1	Communication Signal Terminal Connectors	91
3.5.2	CAN Communication Connection	92
3.5.3	RS485 Communication Connection.....	93
3.5.4	RS232 Communication Connection with PC	95
3.6	Wiring of Analog Monitoring Signal Terminal Connector CN5.....	97
3.7	Anti-interference Measures for Electrical Wiring.....	98
3.7.1	Anti-interference Wiring Example and Grounding.....	98
3.7.2	Using Noise Filter	99
3.8	Precautions of Using Cables	101
3.9	Wiring of Three Control Modes	102
Chapter 4	Operation and Display	110
4.1	Introduction to Keypad	110
4.2	Keypad Display	110
4.2.1	Display Switchover.....	111
4.2.2	Status Display	111
4.2.3	Parameter Display.....	112
4.2.4	Fault Display	113
4.2.5	Monitoring Display.....	114
4.3	Parameter Setting	122
4.4	User Password.....	123
4.5	Common Functions	124
4.5.1	Jog Running.....	124
4.5.2	Forced DI/DO Signal	125
Chapter 5	Control Modes	130
5.1	Basic Setting	131
5.1.1	Check Before Running	132
5.1.2	Power Supply Connection	132
5.1.3	Jogging	133
5.1.4	Selection of Rotating Direction	134
5.1.5	Selection of Output Pulse Phase.....	134
5.1.6	Brake Setting.....	134
5.1.7	Braking Setting.....	139
5.1.8	Servo Running	147
5.1.9	Servo Stop	153
5.2	Position Control Mode.....	156
5.2.1	Position Reference Input Setting	157

5.2.2 Electronic Gear Ratio	174
5.3.2 Position Reference Filter	179
5.2.4 Position Deviation Cleared	181
5.2.5. Frequency-Division Output	182
5.2.6 Positioning Completed/Near Function	184
5.2.7 Position Change on Fly	187
5.2.8 Homing	190
5.2.9 Function Code Block Diagram	206
5.3 Speed Control Mode	207
5.3.1 Speed Reference Input Setting	207
5.3.2 Ramp Function Setting	222
5.3.3 Zero Speed Clamp Function	222
5.3.4 Speed Reference Limit	224
5.3.5 Speed-related DO Signals	225
5.3.6 Function Code Block Diagram	229
5.4 Torque Control Mode	230
5.4.1 Torque Reference Input Setting	230
5.4.2 Torque Reference Filter	237
5.4.3 Torque Reference Limit	239
5.4.4 Speed Limit in Torque Control	246
5.4.5 Torque Reached Output	250
5.4.6 Function Code Block Diagram	252
5.5 Hybrid Control Mode	253
5.6 Descriptions of Absolute System	254
5.6.1 Overview	254
5.6.2 Relevant Parameter Setting	254
5.6.3 Precautions of Battery Box	259
5.6.4 Soft Limit Function	259
5.7 Auxiliary Functions	261
5.7.1 Software Reset	261
5.7.2 Motor Protection	261
5.7.3 DI Filter Time	263
Chapter 6 Adjustment	266
6.1 Overview	266
6.2 Inertia Auto-tuning	268
6.2.1 Offline Inertia Auto-tuning	269
6.2.2 Online Inertia Auto-tuning	272
6.3 Automatic Gain Tuning	273
6.4 Manual Gain Adjustment	276
6.4.1 Basic Parameters	276
6.4.2 Gain Switchover	279
6.4.3 Filter Comparison	285

6.4.4 Feedforward Gain	285
6.4.5 Pseudo-Differential Feedforward Control	288
6.4.6 Torque Disturbance Observer.....	289
6.5 Parameter Adjustment in Different Control Modes	290
6.5.1 Parameter Adjustment in Position Control Mode	290
6.5.2 Parameter Adjustment in Speed Control Mode	292
6.6 Vibration Suppression	292
6.6.1 Suppression of Mechanical Resonance	292
6.6.2 Suppression of Low-frequency Resonance	298
Chapter 7 Description of Parameters	302
Group H00: Servo Motor Parameters.....	302
Group H01: Servo Drive Parameters.....	305
Group H02: Basic Control Parameters	307
Group H03: Input Terminal Parameters.....	315
Group H04: Output Terminal Parameters	326
Group H05: Position Control Parameters	332
Group H06: Speed Control Parameters	349
Group H07: Torque Control Parameters	359
Group H08: Gain Parameters.....	365
Group H09: Automatic Gain Tuning Parameters	372
Group H0A: Fault and Protection Parameters.....	378
Group H0B: Monitoring Parameters	383
Group H0C: Communication Parameters	390
Group H0D: Auxiliary Function Parameters.....	395
Group H0F: Full Closed-Loop Parameters	399
Group H11: Multi-Position Function Parameters	402
Group H12: Multi-Speed Function Parameters.....	407
Group H17: VDI/VDO Parameters.....	410
Group H30: Servo Variables Read by Communication.....	415
Group H31: Servo Variables Set via Communication	416
Chapter 8 Troubleshooting.....	420
8.1 During Startup.....	420
8.1.1 Position Control.....	420
8.1.2 Speed Control	425
8.1.3 Torque Control.....	428
8.2 During Running	430
8.2.1 Fault and Warning Code List.....	430
8.2.2 Troubleshooting of Faults	434
8.2.3 Troubleshooting of Warnings.....	456
8.2.4 Internal Faults	462

Chapter 9 BUS Communication	464
9.1 Modbus Communication.....	464
9.1.1 Hardware Connection and EMC Notice.....	464
9.1.2 Modbus Communication Parameter Setting	468
9.1.3 Modbus Protocol	472
9.1.4 Modbus Communication Troubleshooting	478
9.2 CANlink Communication	481
9.2.1 Hardware Configuration	482
9.2.2 CANlink Communication Parameters Setting	482
9.2.3 CANlink Communication Troubleshooting	483
9.3 CANopen Communication.....	484
9.3.1 Hardware Configuration	485
9.3.2 CANopen Communication Parameters Setting.....	485
9.3.3 CANopen Communication Troubleshooting.....	486
9.4 VDI/VDO	487
Chapter 10 Appendixes.....	492
10.1 Cable Specification	492
10.2 Mounting Dimensions of Servo Motor	494
10.2.1 Mounting Dimensions of ISMH1 Series Z Motor.....	494
10.2.2 Mounting Dimensions of ISMH1 Series X Motor.....	497
10.2.3 Mounting Dimensions of ISMH2 (Vn = 3000 RPM, Vmax = 6000/5000 RPM).....	500
10.2.4 Mounting Dimensions of ISMH3 (Vn = 1500 RPM, Vmax = 3000 RPM).....	502
10.2.5 Mounting Dimensions of ISMH4 (Vn = 3000 RPM, Vmax = 6000 RPM) Series Z Motor..	504
10.2.6 Mounting Dimensions of ISMH4 (Vn = 3000 RPM, Vmax = 6000 RPM) Series X Motor .	506
10.3 Physical Appearance and Mounting Dimensions of Servo Drive	508
10.4 Parameter Table.....	508
Group H00: Servo motor parameters	508
Group H01: Servo Drive Parameters.....	510
Group H02: Basic Control Parameters	510
Group H03: Input Terminal Parameters	512
Group H04: Output Terminal Parameters	515
Group H05: Position Control Parameters	517
Group H06: Speed Control Parameters	522
Group H07: Torque Control Parameters	524
Group H08: Gain Parameters.....	525
Group H09: Automatic Gain Tuning parameters.....	527
Group H0A: Fault and Protection Parameters.....	529
Group H0B: Monitoring Parameters	531
Group H0C: Communication Parameters	533
Group H0D: Auxiliary Function Parameters.....	535
Group H0F: Full Closed-Loop Parameters	536
Group H11: Multi-Position Function Parameters	537

Group H12: Multi-Speed Function Parameters.....	541
Group H17: VDI/VDO Parameters.....	546
Group H30: Servo Variables Read by Communication	550
Group H31: Servo Variables Set via Communication	551
DI/DO Function Definitions.....	551
10.5 Version Record.....	559



*Safety Information and
Precautions*



Safety Information and Precautions

Warnings, Cautions and Notes



A Warning contains information, which is essential for avoiding a safety hazard.



A Caution contains information, which is necessary for avoiding a risk of damage to the product or other machine.

Note

A Note contains information which helps to ensure correct operation.

Electrical Safety

Extreme care must be taken at all times when working with the Servo Drive or within the area of the Servo Drive.

The voltages used in the Servo Drive can cause severe electrical shock or burns and is potentially lethal. Only

authorized and qualified personnel should be allowed to work on Servo Drives.

Machine/System Design and Safety of Personnel

Machine/system design, installation, commissioning startups and maintenance must be carried out by personnel who have the necessary training and experience. They must read this safety information and the contents of this manual. If incorrectly installed, the Servo Drive may present a safety hazard.

The Servo Drive uses high voltages and currents (including DC), carries a high level of stored electrical energy in the DC bus capacitors even after power OFF. These high voltages are potentially lethal.

The Servo Drive is NOT intended to be used for safety related applications/functions. The electronic "STOP&START" control circuits within the Servo Drive must not be relied upon for the safety of personnel. Such control circuits isolates mains power voltages from the output of the Servo Drive. The mains power supply must be disconnected by a electrical safety isolation device before accessing the internal parts of the Servo Drive.

Safety risk assessments of the machine or process system which uses an Servo Drive must be undertaken by the user and or by their systems integrator/designer. In particular the safety assessment/design must take into consideration the consequences of the Servo Drive failing or tripping out during normal operation and whether this leads to a safe stop position without damaging machine, adjacent equipment and machine operators/users. This responsibility lies with the user or their machine/process system integrator.

The system integrator/designer must ensure the complete system is safe and designed according to the relevant safety standards. Inovance Technology and Authorized Distributors can provide recommendations related to the AC drive to ensure long term safe operation.

Working Environment and Handling

Matters related to transport, storage, installation, IP rating, working environment and Servo Drive tolerance limits (temperature, ambient, voltage, pollution, vibration etc) can be found within this manual. The guidelines and recommendations should be followed in order to gain long term trouble free operation as the lifetime of the Servo Drive is dependent on the working environment and correct handling of the product in the initial installation stage.

Electrical Installation - Safety

Electrical shock risk is always present within an Servo Drive including the output cable leading to the motor terminals. Where dynamic brake resistors are fitted external to the Servo Drive, care must be taken with regards to live contact with the brake resistors, terminals which are at high DC voltage and potentially lethal. Cables from the Servo Drive to the regenerative resistors should be double insulated as DC voltages are typically 600 to 700 VDC.

Mains power supply isolation switch should be fitted to the Servo Drive. The mains power supply must be disconnected via the isolation switch before any cover of the Servo Drive can be removed or before any servicing work is undertaken.

Stored charge in the DC bus capacitors of the PWM inverter is potentially lethal after the AC supply has been disconnected. The AC supply must be isolated at least 10 minutes before any work can be undertaken as the stored charge will have been discharged through the internal bleed resistor fitted across the DC bus capacitors.

Whenever possible, it is good practice to check the DC bus voltage with a VDC meter before accessing the inverter bridge. Where the Servo Drive input is connected to the mains supply with a plug and socket, then upon disconnecting the plug and socket, be aware that the plug pins may be exposed and internally connected to the DC bus capacitors (via the internal bridge rectifier in reversed bias). Wait 10 minutes to allow stored charge in the DC bus capacitors to be dissipated by the bleed resistors before commencing work on the Servo Drive.

When using an earth leakage circuit breaker, use a residual current operated protective device (RCD) of type B (breaker which can detect both AC and DC). Leakage current can cause unprotected components to operate incorrectly. If this is a problem, lower the carrier frequency, replace the components in question with parts protected against harmonic current, or increase the sensitivity amperage of the leakage breaker to at least 200 mA per drive.

Factors in determining leakage current:

- Size of the servo drive
- Servo drive carrier frequency
- Motor cable type and length
- EMI/RFI filter

For more information, contact Inovance.

Complying with Local Regulations

The installer of the Servo Drive is responsible for complying with all relevant regulations for wiring, circuit fuse protection, earthing, accident prevention and electromagnetic (EMC regulations). In particular fault discrimination for preventing fire risk and solid earthing practices must be adhered to for electrical safety (also for good EMC practice). Within the European Union, all machinery in which this product is used must comply with the following directives:

- the Low Voltage Directive 2006/95/EC with the Amendment Directive 93/68/EEC
- the Electromagnetic Compatibility Directive 2004/108/EC

AC Motor (Induction/Asynchronous)

AC induction motors are designed to run at fixed speed at the 50 or 60 Hz supply frequency and therefore its cooling capability is dependent on the axial driven fan mounted at the non drive end.

When the motor is operated at variable speed with the Servo Drive, it is necessary to consider the reduced cooling rate especially when running at low speed for considerable period of time. Please consult with the motor manufacturer who can provide cooling solutions such as a electric force ventilated fan or an "inverter" rated AC motor designed to handle reduced speed running with Servo Drives.

It is also necessary to consult with the motor manufacturer when above base speed (> 50/60 Hz) running is required and or when high speed operations are required. Motor suppliers also provide solutions for encoder feedback devices for close loop operation with an Servo Drive.

Adjusting Servo Drive Parameters

The Servo Drive when it leaves the factory with default settings should enable the user to get started quickly to check on the basic mechanical running conditions. At a later time, fine tuning to optimize the operation/performance can be undertaken.

Such parameter tuning should be done by qualified personnel who have prior training on Servo Drives. Some parameter settings can have adverse reactions if manipulated incorrectly and care should be taken especially during the commissioning startup stages to prevent personnel from engaging the machine.

This manual provides a complete list of the parameters with functional description and care should always be taken whenever parameters are adjusted during a live running startup. Inovance Technology and Authorized Distributors can provide product training and if in doubt seek advice.



1 Product Information

1.1 Servo Drive	14
1.1.1 Designation Rules and Nameplate	14
1.1.2 Components of Servo Drive	15
1.1.3 Specifications of Servo Drive	16
1.1.4 Specifications of Regenerative Resistor	21
1.2 Servo Motor	22
1.2.1 Designation Rules and Nameplate	22
1.2.2 Specifications of Servo Motor	23
1.3 Servo System Configuration.....	30
1.4 Matching Cables	31
1.4.1 Servo Motor Power Cable and Encoder Cable	31
1.4.2 Communication Cable	34
1.5 Servo System Wiring.....	34

Chapter 1 Product Information

1.1 Servo Drive

1.1.1 Designation Rules and Nameplate

Figure 1-1 Designation rules and nameplate of servo drive

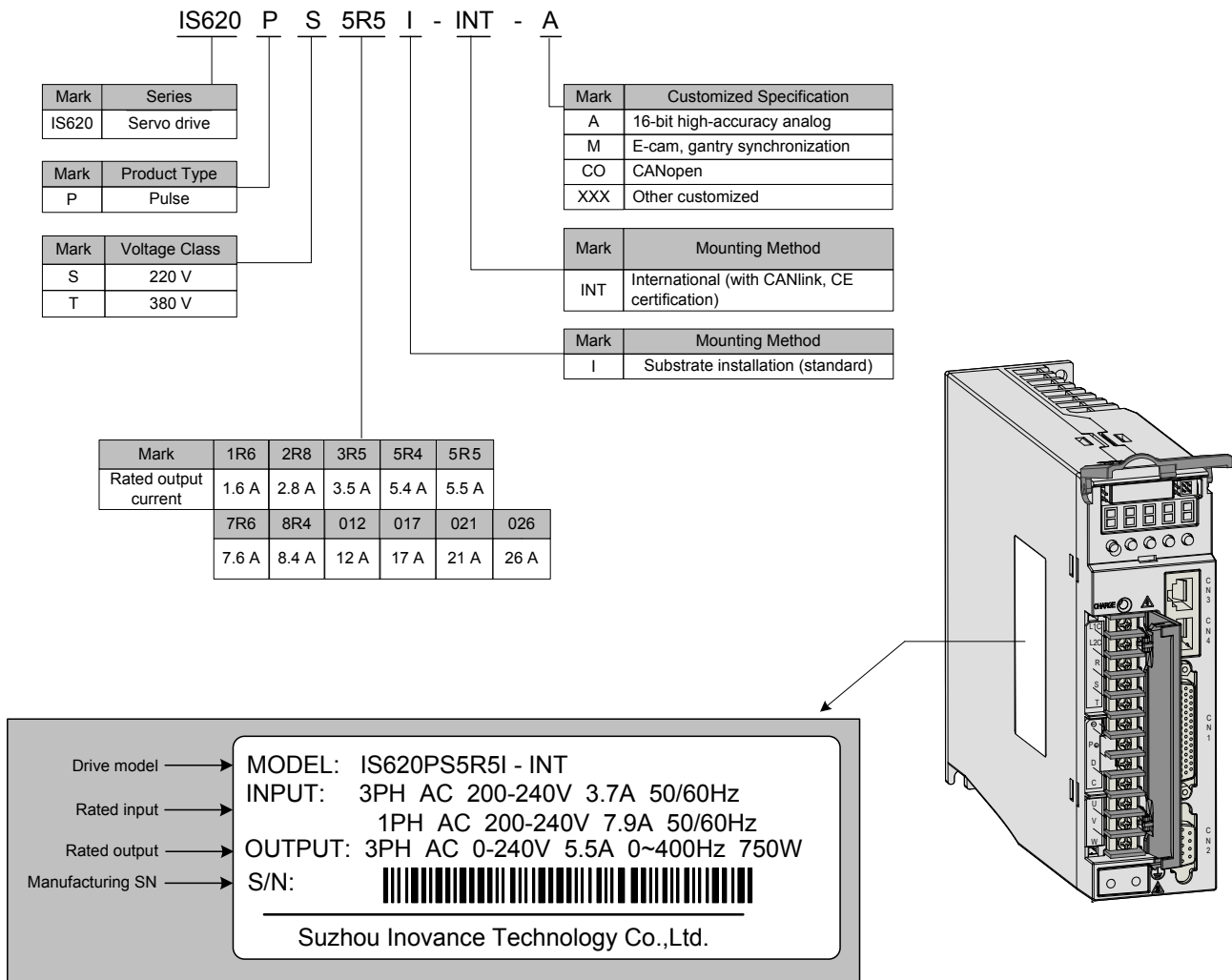

1

1.1.2 Components of Servo Drive

Figure 1-2 Components of servo drive

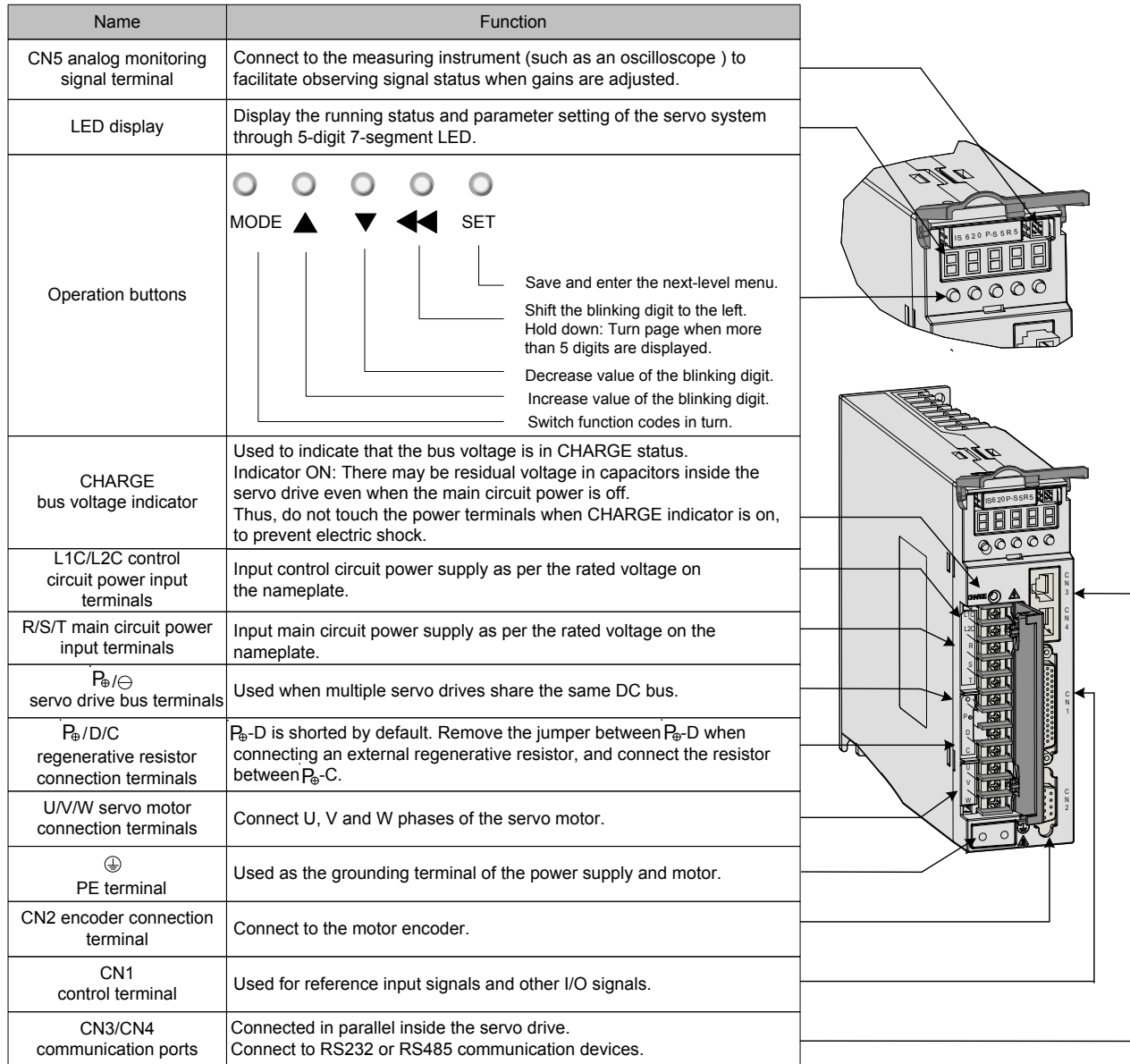

1

Note	<p>1. The preceding figure is applicable only to SIZE A and SIZE C. The terminal arrangement of SIZE E is different from the figure; for details, refer to Chapter 3.</p> <p>2. For single-phase drive models (S1R6, S2R8), the main circuit terminals are L1 and L2.</p> <p>3. These models do not have the built-in regenerative resistor, and therefore terminal D is unavailable. If you need to connect an external regenerative resistor, connect it between P_{\oplus} and C.</p>
-------------	---

1.1.3 Specifications of Servo Drive

1) Electrical specifications

a. Single-phase 220 V

Item	SIZE-A		
	S1R6	S2R8	S5R5
Drive model IS620P	S1R6	S2R8	S5R5
Continuous output current Arms	1.6	2.8	5.5
Maximum output current Arms	5.8	10.1	16.9
Main circuit power supply	Single-phase 200 to 240 VAC, +10% to -10%, 50/60 Hz		
Control circuit power supply	Single-phase 200 to 240 VAC, +10% to -10%, 50/60 Hz		
Braking capability	External regenerative resistor		Built-in regenerative resistor

b. Three-phase 220 V

Item	SIZE-A	SIZE-C	
	S5R5	S7R6	S012
Drive model IS620P	S5R5	S7R6	S012
Continuous output current Arms	5.5	7.6	11.6
Maximum output current Arms	16.9	17	28
Main circuit power supply	Three-phase 200 to 240 VAC, +10% to -10%, 50/60 Hz		
Control circuit power supply	Single-phase 200 to 240 VAC, +10% to -10%, 50/60 Hz		
Braking capability	Built-in regenerative resistor		

c. Three-phase 380 V

Item	SIZE-C				SIZE-E		
	T3R5	T5R4	T8R4	T012	T017	T021	T026
Drive model IS620P	T3R5	T5R4	T8R4	T012	T017	T021	T026
Continuous output current Arms	3.5	5.4	8.4	11.9	16.5	20.8	25.7
Maximum output current Arms	8.5	14	20	24	42	55	65
Main circuit power supply	Single-phase 380 to 480 VAC, +10% to -10%, 50/60 Hz						
Control circuit power supply	Single-phase 380 to 480 VAC, +10% to -10%, 50/60 Hz						
Braking capability	Built-in regenerative resistor						

2) Basic specifications

Item		Description		
Basic specifications	Control mode		IGBT PWM control, sine wave current drive mode 220 V, 380 V: single/three-phase full wave rectification	
	Encoder feedback		20-bit serial incremental encoder	
	Use conditions	Use/Storage temperature (Note 1)		0–45°C (derated when above 45°C, average load ratio < 80%), 40–70°C (electric cabinet)
		Use/Storage humidity		Below 90% RH (no condensation)
		Vibration/Impact resistance		4.9 m/s ² , 19.6 m/s ²
		Degree of protection		IP10
		Pollution degree		Level 2
		Altitude		Below 1000 m
Position control mode	Performance	Feedforward compensation		0–100.0% (resolution: 0.1%)
		Threshold for positioning completed		1–65535 encoder units
	Input signal	Pulse	Input pulse format	Direction + pulse Phase A + B quadrature pulse CW/CCW pulse
			Input mode	Differential input Open collector
		Input pulse frequency	Differential input: maximum speed 4 Mpps, pulse width not lower than 0.125 μs	
			Low speed limit to 500 Kpps, pulse width not lower than 1 μs Open collector: maximum 200 Kpps, pulse width not lower than 2.5 μs	
	Power supply for built-in open collector		+24 V (built-in 2.4 kΩ resistor)	
	Multi-position reference selection		Four DIs are allocated with functions CMD1, CMD2, CMD3, and CMD4 to implement selection of 16 positions.	
	Position output	Output mode		Phase A, phase B: differential output Phase Z: differential output or open collector output
		Frequency division ratio		Any frequency division

1

Item			Description	
Speed/Torque control mode	Performance	Velocity regulated ratio (Note 2)	Load change rate	Below 0.5% at 0–100% load (under rated speed)
			Voltage change rate	Rated voltage $\pm 10\%$: 0.5% (under rated speed)
			Temperature change rate	25 \pm 25°C: below 0.5% (under rated speed)
		Speed range		1:5000
		Frequency characteristics		IS620P: 1.2 KHz
		Torque control accuracy		$\pm 2\%$
		Soft startup time setting		0–60s (acceleration and deceleration can be set)
	Input signal	Speed reference input	Reference voltage (Note 3)	± 10 VDC, ordinary 12 bits, maximum 16 bits (16-bit resolution analog input is customized)
				Input voltage: maximum ± 12 V
			Input impedance	About 9 k Ω
		Circuit time parameter		About 47 μ s
		Torque reference input	Reference voltage	± 10 VDC, ordinary 12 bits, maximum 16 bits (16-bit resolution analog input is customized)
				Input voltage: maximum ± 12 V
			Input impedance	About 9 k Ω
		Circuit time parameter		About 47 μ s
Multi-speed reference		Speed selection	Four DIs are allocated with functions CMD1, CMD2, CMD3, and CMD4 to implement selection of 16 speeds.	

Item		Description
Input/Output signal	Digital input signal	<p>9 DIs (DI8 and DI9 being high-speed DI)</p> <p>37 DI functions:</p> <p>S-ON, fault/warning reset, gain switchover</p> <p>Main/auxiliary running reference switchover, multi-speed DI switchover, running direction selection, multi-reference switchover (4 DIs)</p> <p>Zero speed clamp, position reference inhibited</p> <p>Forward limit switch, negative limit switch</p> <p>External positive torque limit, external negative torque limit</p> <p>Forward jog, reverse jog, step reference</p> <p>Handwheel multiplying factor signal 1, handwheel multiplying factor signal 2, handwheel enabled</p> <p>Electronic gear selection, torque reference direction selection, speed reference direction selection, position reference direction selection</p> <p>Multi-position enable, position change on fly unlock, position change on fly inhibited</p> <p>Home switch, homing function, braking</p> <p>Position deviation cleared, internal speed limit source, pulse reference inhibited</p>
	Digital output signal	<p>5 DOs</p> <p>19 DO functions:</p> <p>Servo ready, motor rotation output, zero speed signal</p> <p>Speed consistent, positioning completed, Positioning near</p> <p>Torque limit, speed limit, brake output</p> <p>Warning output, fault output, fault code output (3-digit output)</p> <p>Position change on fly completed, home attaining output, electrical home attaining output</p> <p>Torque reached, speed reached</p>

1

Item		Description	
Built-in functions	Stop at limit switch	The servo drive stops immediately when P-OT or N-OT is active.	
	Electronic gear ratio	$0.1048576 \leq B/A \leq 419430.4$	
	Protection functions	Overcurrent, overvoltage, undervoltage Overload, main circuit detection abnormal Heatsink overheat, phase loss, overspeed Encoder abnormal, CPU abnormal, parameter abnormal, etc.	
	LED display	Main circuit CHARGE indicator, 5-digit LED display	
	Analog monitoring	Built-in analog monitoring connector for observing speed and torque reference signals	
	Communication function	Connection device	RS232. RS485 CAN communication optional
		Communication protocol	Modbus, CANlink, CANopen (CANlink and CANopen customized)
		1: N communication	Maximum N = 247 for RS485
		Servo axis address setting	Set based on user requirements
		Function	Status display, user parameter setting, monitoring display Alarm tracing display, jog running and auto-tuning operation Speed/Torque reference signal observation
Others	Gain adjustment, alarm record, jog running		

Note	<p>1. Install the servo drive within the ambient temperature range. When it is installed in the electric cabinet, the temperature inside the cabinet must be within this range.</p> <p>2. The velocity regulated ratio is defined as follows:</p> $\text{Velocity regulated ratio} = \frac{\text{No-load speed} - \text{Full load speed}}{\text{Rated speed}} \times 100\%$ <p>Actually, the amplifier deviation is caused by voltage change and temperature change, resulting in change to the calculated resistance. Such changes is reflected by speed change. The speed change rate is expressed by a percentage to the rated speed, and includes the values at voltage change and temperature change.</p> <p>3. Forward rotation: Observed from the motor shaft side, the motor rotates counter clockwise.</p> <p>4. The internal open collector power supply is not electrically insulated from the control circuit in the servo drive.</p>
-------------	---

1.1.4 Specifications of Regenerative Resistor

Drive Model Resistance (Ω)		Built-in Regenerative Resistor Specs		Min. Allowed Resistance (Ω)	Max. Braking Energy Absorbed by Capacitor (J)	
		Power (W)				
Single-phase 220 V	IS620PS1R6I	-	-	50	9	
	IS620PS2R8I	-	-	45	18	
Single/ Three-phase 220 V	IS620PS5R5I	50	50	40	26	
Three-phase 220 V	IS620PS7R6I	25	80	20	26	
	IS620PS012I			15	47	
Three-phase 380 V	IS620PT3R5I	100	80	80	28	
	IS620PT5R4I	100	80	60	34	
	IS620PT8R4I	50	80	45	50	
	IS620PT012I				50	
	IS620PT017I	40	100	35	81	
	IS620PT021I				25	122
	IS620PT026I					122

Note	<p>Models S1R6 and S2R8 are not configured with a built-in regenerative resistor. Use an external regenerative resistor if necessary.</p> <p>For use for the external regenerative resistor, refer to section 5.1.7.</p>
-------------	--

1.2 Servo Motor

1.2.1 Designation Rules and Nameplate

Figure 1-3 Designation rules and nameplate of servo motor

ISM H1-75B 30C B-U2 3 1 Z

Mark	Series
ISM	ISM series servo motor

Mark	Feature
H	1 Low inertia, 40/60/80 mm flange
	2 Low inertia, 100/130 mm flange
	3 Medium inertia, 130/180 mm flange
	4 Medium inertia, 60/80 mm flange

Mark	Rated Power (W)
A	x 1
B	x 10
C	x 100
D	x 1000
E	x 10000

Example
75B: 750 W
15C: 1500 W

Mark	Rated Speed (RPM)
A	x 1
B	x 10
C	x 100
D	x 1000
E	x 10000

Example
15B: 150 RPM
30C: 3000 RPM

Mark	Voltage Class
B	220 V
D	380 V

Mark	Customized Feature
Y	Military spec. connection
Z	2nd generation motor



Mark	Brake, Oil Sealing
0	None
1	Oil sealing
2	Brake
4	Brake + oil sealing

Mark	Motor Shaft
1	Plain
2	Keyed
3	Keyed + tapped hole
5	Tapped hole

Mark	Encoder Type
1 letter + 1 digit	
U	2 20-bit serial
A	3 23-bit multi-turn absolute

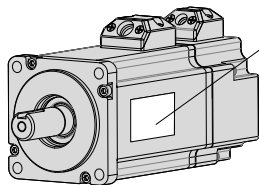
1



Motor nameplate		ISMH Series AC Servo motor	
			IEC60034
Model	Model	ISMH1-75B30CB	
Parameters	Pn(W)	Un(V)	In(A)
	750	220	4.8
	Nn(r/min)	Tn(Nm)	Duty
	3000	2.39	S1
	F _n (Hz)	Ins.	EFF.: 81.5%
	250	F	
	IP65	3PH AC	Max rev.(r/min)
			6000
Code	Motor Code:	14000 Weight(kg):2.7 Type:U231Z	
SN	S/N:	01110462 *****	
			
		Manufacturer: Suzhou Inovance Technology Co.,Ltd.	
		Address: No.16, Youxiang Road, YueXi Town, Wuzhong District, Suzhou 215104, P.R.China	

1.2.2 Specifications of Servo Motor

1) Motor mechanical characteristics

Item	Description
Rated time	Continuous
Vibration level	V15
Insulation resistance	500 VDC, above 10 MΩ
Use ambient temperature	0–40°C
Excitation mode	Permanent magnetic
Installation method	Flange
Heat-resistance level	H1, H4: B Other: F
Insulation voltage	1500 VAC, 1 minute (200 V) 1800 VAC, 1 minute (400 V)
Housing protection mode	H1, H4: IP65 (except the through-shaft section) Other: IP67
Use environment humidity	20%–80% (no condensation)
Connection mode	Direct connection
Rotating direction	The motor rotates counterclockwise viewed from the load side (CCW) at the forwarding rotation command.

1

2) Motor ratings

Servo Motor Model	Rated Output (kW) (Note 1)	Rated Torque (N·m)	Max. Torque (N·m)	Rated Curr. (A)	Max. Curr. (A)	Rated Speed (RPM)	Max. Speed (RPM)	Torque Para. (N·m/A)	Rotor Inertia (10 ⁻⁴ kg·m ²)	Voltage (V)
ISMH1 (V _n = 3000 RPM, V _{max} = 6000 RPM)										
ISMH1-10B30CB-U***Z	0.1	0.32	0.96	1.1	3.3	3000	6000	0.298	0.046 (0.048) (Note 2)	220
ISMH1-20B30CB-U***Z	0.2	0.63	1.91	1.6	5.12			0.50	0.149 (0.163)	
ISMH1-40B30CB-U***Z	0.4	1.27	3.82	2.8	8.96			0.50	0.25	
ISMH1-55B30CB-U***Z	0.55	1.75	5.25	3.8	12.2			0.496	1.04	
ISMH1-75B30CB-U***Z	0.75	2.39	7.16	4.80	15.10			0.57	1.3	
ISMH1-10C30CB-U***Z	0.75	3.18	9.55	7.6	24.5			0.485	1.7	

Servo Motor Model	Rated Output (kW) (Note 1)	Rated Torque (N·m)	Max. Torque (N·m)	Rated Curr. (A)	Max. Curr. (A)	Rated Speed (RPM)	Max. Speed (RPM)	Torque Para. (N·m/A)	Rotor Inertia (10 ⁻⁴ kg·m ²)	Voltage (V)
ISMH 2 (Vn = 3000 RPM, Vmax = 6000/5000 RPM)										
ISMH2-10C30CB-U***Y	1.0	3.18	9.54	7.5	23.00	3000	6000	0.43	1.87 (3.12)	220
ISMH2-15C30CB-U***Y	1.5	4.90	14.7	10.8	32.00		5000	0.45	2.46 (3.71)	
ISMH2-10C30CD-U***Y	1.0	3.18	9.54	3.65	11.00		6000	0.87	1.87 (3.12)	380
ISMH2-15C30CD-U***Y	1.5	4.90	14.7	4.50	14.00		5000	1.09	2.46 (3.71)	
ISMH2-20C30CD-U***Y	2.0	6.36	19.1	5.89	20.00	3000	5000	1.08	3.06	380
ISMH2-25C30CD-U***Y	2.5	7.96	23.9	7.56	25.00			1.05	3.65	
ISMH2-30C30CD-U***Y	3.0	9.8	29.4	10.00	30.00			0.98	7.72	
ISMH2-40C30CD-U***Y	4.0	12.6	37.8	13.60	40.80			0.93	12.1	
ISMH2-50C30CD-U***Y	5.0	15.8	47.6	16.00	48.00			1.07	15.4	
ISMH3 (Vn = 1500 RPM, Vmax = 3000 RPM)										
ISMH3-85B15CB-U***Y	0.85	5.39	13.5	6.60	16.50	1500	3000	0.9	13 (15.5)	220
ISMH3-13C15CB-U***Y	1.3	8.34	20.85	10.00	25.00			0.9	19.3 (21.8)	
ISMH3-85B15CD-U***Y	0.85	5.39	13.5	3.30	8.25			1.75	13 (15.5)	380
ISMH3-13C15CD-U***Y	1.3	8.34	20.85	5.00	12.50			1.78	19.3 (21.8)	
ISMH3-18C15CD-U***Y	1.8	11.5	28.75	6.60	16.50			1.8	25.5 (28)	
ISMH3-29C15CD-U***Z	2.9	18.6	37.2	11.90	28.00			1.7	55 (57.2)	
ISMH3-44C15CD-U***Z	4.4	28.4	71.1	16.50	40.50			1.93	88.9 (90.8)	
ISMH3-55C15CD-U***Z	5.5	35.0	87.6	20.85	52.00			1.80	107 (109.5)	
ISMH3-75C15CD-U***Z	7.5	48.0	119	25.70	65.00			1.92	141 (143.1)	

1

Servo Motor Model	Rated Output (kW) (Note 1)	Rated Torque (N·m)	Max. Torque (N·m)	Rated Curr. (A)	Max. Curr. (A)	Rated Speed (RPM)	Max. Speed (RPM)	Torque Para. (N·m/A)	Rotor Inertia (10 ⁻⁴ kg·m ²)	Voltage (V)
ISMH4 (Vn = 3000 Rpm, Vmax = 6000 RPM)										
ISMH4-40B30CB-U***Z	0.4	1.27	3.82	2.80	10.10	3000	6000	0.50	(0.667)	220
ISMH4-75B30CB-U***Z	0.75	2.39	7.16	4.80	15.10			0.57	(2.033)	

Note	<p>Note 1: The motor with oil sealing must be derated by 10% during use.</p> <p>Note 2: Parameters in () are for the motor with brake.</p> <p>The parameters in the preceding table are the values when the motor works together with Inovance servo drive and the armature coil temperature is 20°C.</p> <p>The preceding features are based on the cooling conditions when the following heatsinks are installed.</p> <p>ISMH1/ISMH4: 250 x 250 x 6 mm (aluminum)</p> <p>ISMH2-10C to 25C: 300 x 300 x 12 mm (aluminum)</p> <p>ISMH2-30C to 50C: 400 x 400 x 20 mm (aluminum)</p> <p>ISMH3-85B to 18C: 400 x 400 x 20 mm (metal)</p> <p>ISMH3-29C to 75C: 360 x 360 x 5 mm (double aluminum plate)</p>
------	---

1

3) Motor overload characteristics

Load Ratio (%)	Running Time (s)
120	230
130	80
140	40
150	30
160	20
170	17
180	15
190	12
200	10
210	8.5
220	7
230	6
240	5.5
250	5
300	3

Figure 1-4 Motor overload curve

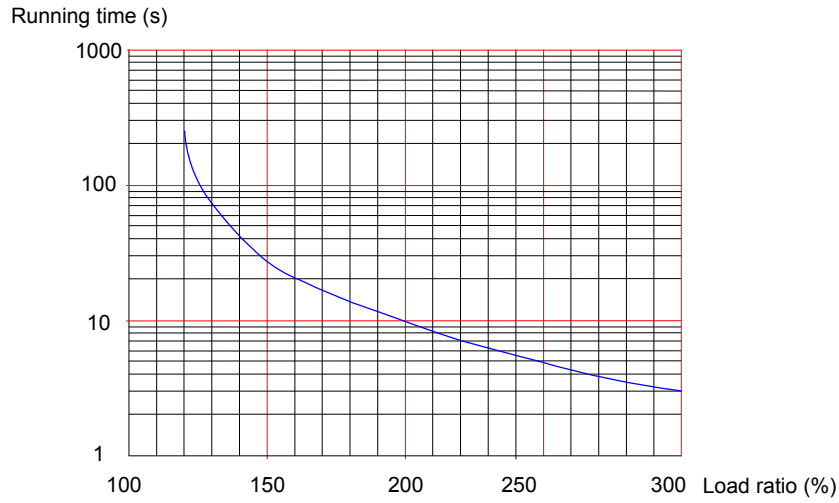

1

Note	<p>1. The maximum torque of H1, H2, and H4 are 3 times of the rated torque.</p> <p>2. Except for the 2.9 kW model, the maximum torque of H3 is 2.5 times of the rated torque.</p> <p>3. The maximum torque of the 2.9 kW model is 2 times of the rated torque.</p>
-------------	--

4) Motor Radial and Axial Loads

Figure 1-5 Motor radial and axial load diagram

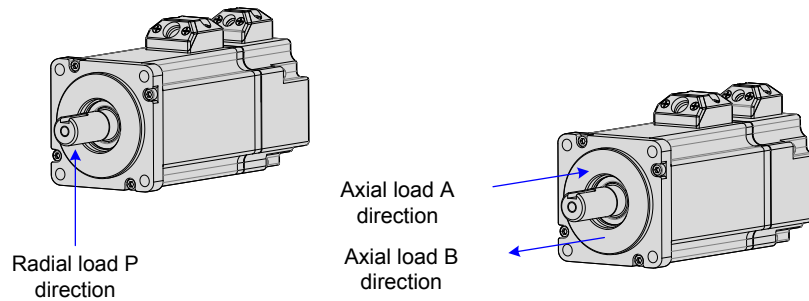

Servo Motor Model	Allowed Radial Load (N)	Allowed Axial Load (N)
ISMH1-10B30CB-U***Z	78	54
ISMH1-20B30CB-U***Z	245	74
ISMH1-40B30CB-U***Z	245	74
ISMH1-55B30CB-U***Z	245	74
ISMH1-75B30CB-U***Z	392	147
ISMH1-10C30CB-U***Z	245	74
ISMH2-10C30CB-U***Y	686	196
ISMH2-15C30CB-U***Y	686	196
ISMH2-10C30CD-U***Y	686	196
ISMH2-15C30CD-U***Y	686	196
ISMH2-20C30CD-U***Y	686	196
ISMH2-25C30CD-U***Y	686	196
ISMH2-30C30CD-U***Y	980	392

Servo Motor Model	Allowed Radial Load (N)	Allowed Axial Load (N)
ISMH2-40C30CD-U***Y	1176	392
ISMH2-50C30CD-U***Y	1176	392
ISMH3-85B15CB-U***Y	490	98
ISMH3-13C15CB-U***Y	686	343
ISMH3-85B15CD-U***Y	490	98
ISMH3-13C15CD-U***Y	686	343
ISMH3-18C15CD-U***Y	980	392
ISMH3-29C15CD-U***Z	1470	490
ISMH3-44C15CD-U***Z	1470	490
ISMH3-55C15CD-U***Z	1764	588
ISMH3-75C15CD-U***Z	1764	588
ISMH4-40B30CB-U***Z	245	74
ISMH4-75B30CB-U***Z	392	147

5) Electrical specifications of motor brake

Servo Motor Model	Holding Torque (Nm)	Supplied Voltage (V) $\pm 10\%$	Resistor (Ω) $\pm 7\%$	Supplied Current Range (A)	Brake Release Time (ms)	Brake Apply Time (ms)
ISMH1-10B	0.32	24	96	0.23–0.27	10	30
ISMH1-20B/40B	1.3	24	82.3	0.25–0.34	20	50
ISMH1-75B	2.39	24	50.1	0.40–0.57	25	60
ISMH2-10C/15C/20C/25C	8	24	25	0.81–1.14	30	90
ISMH2-30C/40C/50C	16	24	21.3	0.95–1.33	60	120
ISMH3-85B/13C/18C	16	24	21.3	0.95–1.33	60	120
ISMH3-29C/44C/55C/75C	48	24	13.7	1.47–2.07	100	230
ISMH4-40B	1.3	24	82.3	0.25–0.34	20	50
ISMH4-75B	2.39	24	50.1	0.40–0.57	25	60

Note

1. The brake must not share power supply with other electrical devices. This is to prevent malfunction of the brake due to voltage or current drop when other electrical devices work.
2. Cables of 0.5 mm² and above are recommended.

6) Motor torque/speed characteristics

a. ISMHH1 (low inertia, 40/60/80 mm flange)

- A █ Continuous operating area
- B █ Short-time operating area

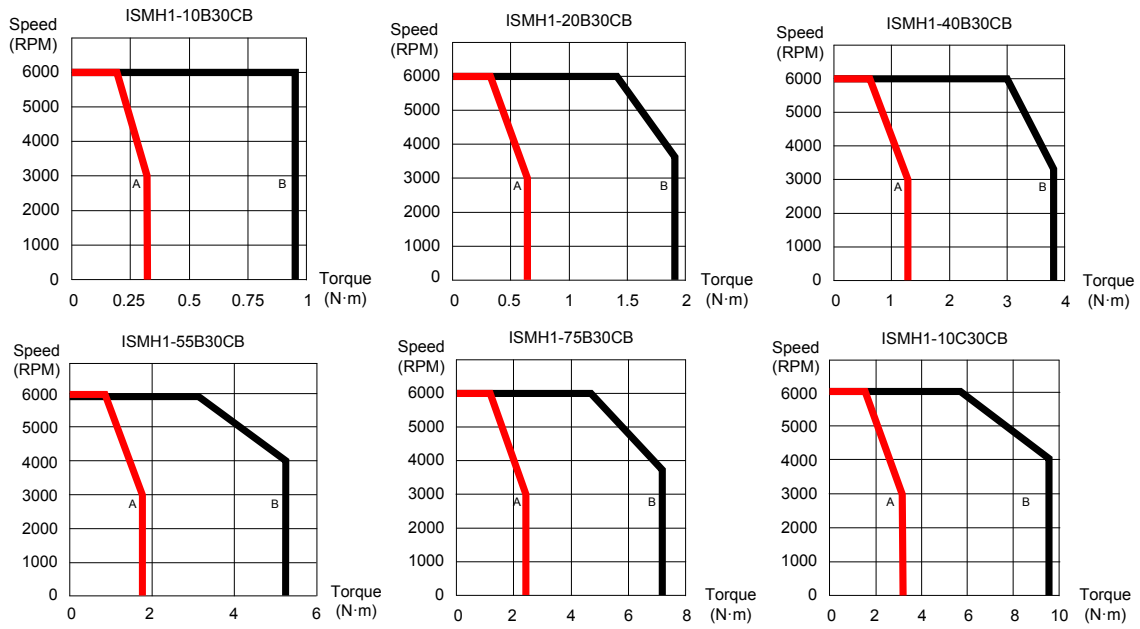

b. ISMH2 (low inertia, 100/130 mm flange)

- A █ Continuous operating area
- B █ Short-time operating area

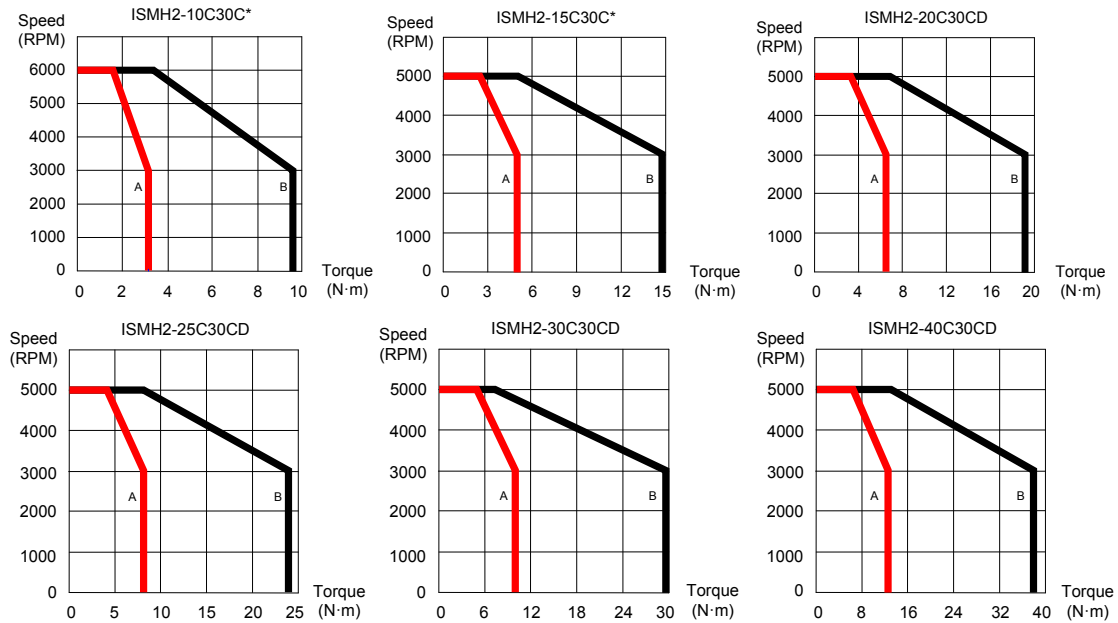

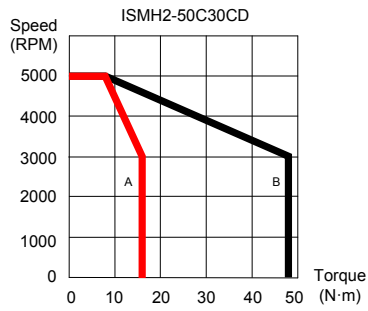

c. ISMH3 (medium inertia, 130/180 mm flange)

A █ Continuous operating area

B █ Short-time operating area

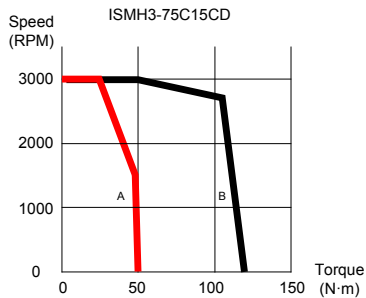
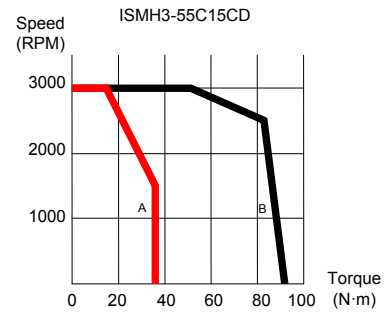
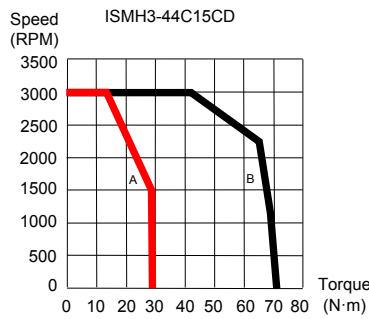
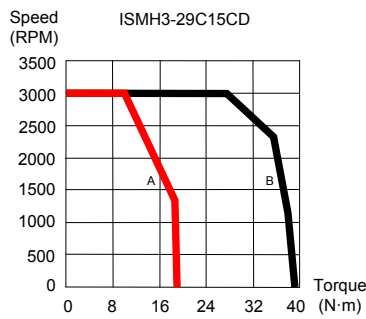
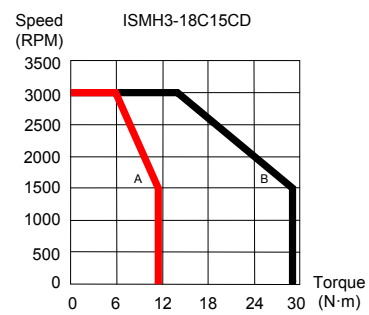
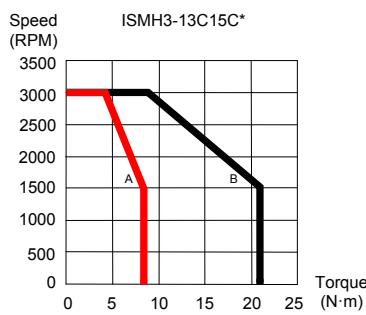
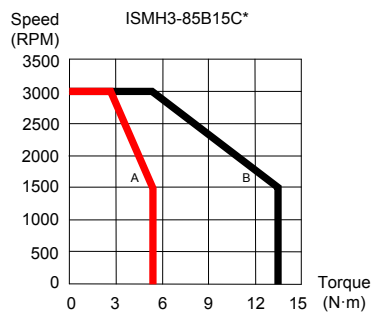

d. ISMH4 (low inertia, 60/80 mm flange)

A █ Continuous operating area

B █ Short-time operating area

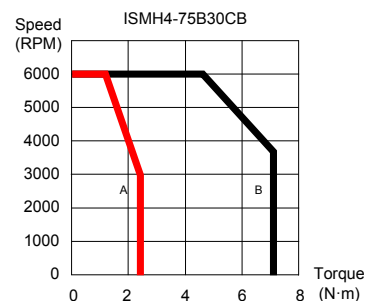
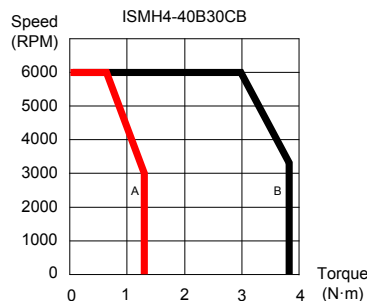

1.3 Servo System Configuration

220 V:

Rated Speed (RPM)	Max. Speed (RPM)	Capacity (W)	Servo Motor Model ISMH*-*****_****		Motor Frame	Drive Model IS620P****]		Drive Size	Drive SN (H01-02)
						Single-phase 220 VAC	Three-phase 220 VAC		
3000	6000	200	H1 (low inertia, 40/60/80 mm flange)	20B30CB	60	S1R6		A	00002
		400		40B30CB	60	S2R8		A	00003
		550		55B30CB	80	S5R5		A	00005
		750		75B30CB	80	S5R5		A	00005
		1000		10C30CB	80	S7R6		C	00006
	1000	H2 (low inertia, 100/130 mm flange)	10C30CB	100		S7R6	C	00006	
	5000		15C30CB	100		S012	C	00007	
1500	3000	850	H3 (medium inertia, 130/180 mm flange)	85B15CB	130		S7R6	C	00006
		1300		13C15CB	130		S012	C	00007
3000	6000	400	H4 (low inertia, 60/80 mm flange)	40B30CB	60	S2R8		A	00003
		750		75B30CB	80	S5R5		A	00005

380 V:

Rated Speed (RPM)	Max. Speed (RPM)	Capacity (W)	Servo Motor Model ISMH*-*****_****		Motor Frame	Drive Model	Drive Size	Drive SN (H01-02)
						Three-phase 380 VAC		
3000	6000	1000	H2 (low inertia, 100/130 mm flange)	10C30CD	100	T5R4	C	10002
		1500		15C30CD	100	T5R4	C	10002
		2000		20C30CD	100	T8R4	C	10003
		2500		25C30CD	100	T8R4	C	10003
		3000		30C30CD	130	T012	C	10004
		4000		40C30CD	130	T017	E	10005
		5000		50C30CD	130	T017	E	10005
1500 RPM	3000 RPM	850	H3 (medium inertia, 130/180 mm flange)	85B15CD	130	T3R5	C	10001
		1300		13C15CD	130	T5R4	C	10002
		1800		18C15CD	130	T8R4	C	10003
		2900		29C15CD	180	T012	C	10004
		4400		44C15CD	180	T017	E	10005
		5500		55C15CD	180	T021	E	10006
		7500		75C15CD	180	T026	E	10007

1.4 Matching Cables

1.4.1 Servo Motor Power Cable and Encoder Cable

Models Without Brake

Motor Model	Power Cable and Encoder Cable of Servo Motor Without Brake		
	L = 3.0 m	L = 5.0 m	L = 10.0 m
ISMH1-*****-U1*** ISMH1-*****-U2*** ISMH4-*****-U1*** ISMH4-*****-U2***	S6-L-M00-3.0 (power cable) S6-L-P00-3.0 (incremental encoder cable)	S6-L-M00-5.0 (power cable) S6-L-P00-5.0 (incremental encoder cable)	S6-L-M00-10.0 (power cable) S6-L-P00-10.0 (incremental encoder cable)
ISMH1-*****-A3*** ISMH4-*****-A3***	S6-L-M00-3.0 (power cable) S6-L-P20-3.0 (absolute encoder cable)	S6-L-M00-5.0 (power cable) S6-L-P20-5.0 (absolute encoder cable)	S6-L-M00-10.0 (power cable) S6-L-P20-10.0 (absolute encoder cable)
ISMH2-*****-U1*** ISMH2-*****-U2***	S6-L-M11-3.0 (power cable) S6-L-P01-3.0	S6-L-M11-5.0 (power cable) S6-L-P01-5.0 (incremental encoder cable)	S6-L-M11-10.0 (power cable) S6-L-P01-10.0 (incremental encoder cable)
ISMH2-*****-A3***	S6-L-M11-3.0 (power cable) S6-L-P21-3.0 (absolute encoder cable)	S6-L-M11-5.0 (power cable) S6-L-P21-5.0 (absolute encoder cable)	S6-L-M11-10.0 (power cable) S6-L-P21-10.0 (absolute encoder cable)
ISMH3-*****-U1*** ISMH3-*****-U2*** (1.8 kW and below)	S6-L-M11-3.0 (power cable) S6-L-P01-3.0 (incremental encoder cable)	S6-L-M11-5.0 (power cable) S6-L-P01-5.0 (incremental encoder cable)	S6-L-M11-10.0 (power cable) S6-L-P01-10.0 (incremental encoder cable)
ISMH3-*****-A3*** (1.8 kW and above)	S6-L-M11-3.0 (power cable) S6-L-P21-3.0 (absolute encoder cable)	S6-L-M11-5.0 (power cable) S6-L-P21-5.0 (absolute encoder cable)	S6-L-M11-10.0 (power cable) S6-L-P21-10.0 (absolute encoder cable)
ISMH3-*****-U1*** ISMH3-*****-U2*** (2.9 kW)	S6-L-M12-3.0 (power cable) S6-L-P01-3.0 (incremental encoder cable)	S6-L-M12-5.0 (power cable) S6-L-P01-5.0 (incremental encoder cable)	S6-L-M12-10.0 (power cable) S6-L-P01-10.0 (incremental encoder cable)
ISMH3-*****-A3*** (2.9 kW)	S6-L-M12-3.0 (power cable) S6-L-P21-3.0 (absolute encoder cable)	S6-L-M12-5.0 (power cable) S6-L-P21-5.0 (absolute encoder cable)	S6-L-M12-10.0 (power cable) S6-L-P21-10.0 (absolute encoder cable)

Motor Model	Power Cable and Encoder Cable of Servo Motor Without Brake		
	L = 3.0 m	L = 5.0 m	L = 10.0 m
ISMH3-*****-U1*** ISMH3-*****-U2*** (above 2.9 kW)	S6-L-M22-3.0 (power cable) S6-L-P01-3.0 (incremental encoder cable)	S6-L-M22-5.0 (power cable) S6-L-P01-5.0 (incremental encoder cable)	S6-L-M22-10.0 (power cable) S6-L-P01-10.0 (incremental encoder cable)
ISMH3-*****-A3*** (above 2.9kW)	S6-L-M22-3.0 (power cable) S6-L-P21-3.0 (absolute encoder cable)	S6-L-M22-5.0 (power cable) S6-L-P21-5.0 (absolute encoder cable)	S6-L-M22-10.0 (power cable) S6-L-P21-10.0 (absolute encoder cable)

Models with Brake

1

Motor Model	Power Cable and Encoder Cable of Servo Motor With Brake		
	L = 3.0 m	L = 5.0 m	L = 10.0 m
ISMH1-*****-U1*** ISMH1-*****-U2*** ISMH4-*****-U1*** ISMH4-*****-U2***	S6-L-B00-3.0 (power cable) S6-L-P00-3.0 (incremental encoder cable)	S6-L-B00-5.0 (power cable) S6-L-P00-5.0 (incremental encoder cable)	S6-L-B00-10.0 (power cable) S6-L-P00-10.0 (incremental encoder cable)
ISMH1-*****-A3*** ISMH4-*****-A3***	S6-L-B00-3.0 (power cable) S6-L-P20-3.0 (absolute encoder cable)	S6-L-B00-5.0 (power cable) S6-L-P20-5.0 (absolute encoder cable)	S6-L-B00-10.0 (power cable) S6-L-P20-10.0 (absolute encoder cable)
ISMH2-*****-U1*** ISMH2-*****-U2***	S6-L-B11-3.0 (power cable) S6-L-P01-3.0	S6-L-B11-5.0 (power cable) S6-L-P01-5.0 (incremental encoder cable)	S6-L-B11-10.0 (power cable) S6-L-P01-10.0 (incremental encoder cable)
ISMH2-*****-A3***	S6-L-B11-3.0 (power cable) S6-L-P21-3.0 (absolute encoder cable)	S6-L-B11-5.0 (power cable) S6-L-P21-5.0 (absolute encoder cable)	S6-L-B11-10.0 (power cable) S6-L-P21-10.0 (absolute encoder cable)
ISMH3-*****-U1*** ISMH3-*****-U2*** (1.8 kW and below)	S6-L-B11-3.0 (power cable) S6-L-P01-3.0 (incremental encoder cable)	S6-L-B11-5.0 (power cable) S6-L-P01-5.0 (incremental encoder cable)	S6-L-B11-10.0 (power cable) S6-L-P01-10.0 (incremental encoder cable)
ISMH3-*****-A3*** (1.8 kW and below)	S6-L-B11-3.0 (power cable) S6-L-P21-3.0 (absolute encoder cable)	S6-L-B11-5.0 (power cable) S6-L-P21-5.0 (absolute encoder cable)	S6-L-B11-10.0 (power cable) S6-L-P21-10.0 (absolute encoder cable)
ISMH3-*****-U1*** ISMH3-*****-U2*** (2.9 kW)	Power cable: prepared by customer		
	S6-L-P01-3.0 (incremental encoder cable)	S6-L-P01-5.0 (incremental encoder cable)	S6-L-P01-10.0 (incremental encoder cable)

Motor Model	Power Cable and Encoder Cable of Servo Motor With Brake		
	L = 3.0 m	L = 5.0 m	L = 10.0 m
ISMH3-*****-A3*** (2.9 kW)	Power cable: prepared by customer		
	S6-L-P21-3.0 (absolute encoder cable)	S6-L-P21-5.0 (absolute encoder cable)	S6-L-P21-10.0 (absolute encoder cable)
ISMH3-*****-U1*** ISMH3-*****-U2*** (above 2.9 kW)	Power cable: prepared by customer		
	S6-L-P01-3.0 (incremental encoder cable)	S6-L-P01-5.0 (incremental encoder cable)	S6-L-P01-10.0 (incremental encoder cable)
ISMH3-*****-A3*** (above 2.9 kW)	Power cable: prepared by customer		
	S6-L-P21-3.0 (absolute encoder cable)	S6-L-P21-5.0 (absolute encoder cable)	S6-L-P21-10.0 (absolute encoder cable)

Connector kit

1

Motor Model	Connector Kit	Optional Battery Kit of Absolute Encoder Motor
ISMH1-*****-U1*** ISMH1-*****-U2*** ISMH4-*****-U1*** ISMH4-*****-U2***	S6-C1 Including: CN1 terminal, CN2 terminal, 6-pin connector, 9-pin connector	-
ISMH1-*****-A3*** ISMH4-*****-A3***		S6-C4 (battery, battery box)
ISMH2-*****-U1*** ISMH2-*****-U2***	S6-C2 Including: CN1 terminal, CN2 terminal, 20-18 military spec. plug (elbow), 20-29 military spec. plug (elbow)	-
ISMH2-*****-A3***		S6-C4 (battery, battery box)
ISMH3-*****-U1*** ISMH3-*****-U2***	S6-C2 Including: CN1 terminal, CN2 terminal, 20-18 military spec. plug (elbow), 20-29 military spec. plug (elbow)	-
ISMH3-*****-A3*** (1.8 kW and below)		S6-C4 (battery, battery box)
ISMH3-*****-U1*** ISMH3-*****-U2***	S6-C3 Including: CN1 terminal, CN2 terminal, 20-22 military spec. plug (elbow), 20-29 military spec. plug (elbow)	-
ISMH3-*****-A3*** (2.9 kW)		S6-C4 (battery, battery box)
ISMH3-*****-U1*** ISMH3-*****-U2***		-
ISMH3-*****-A3*** (2.9 kW and above)		S6-C4 (battery, battery box)

1.4.2 Communication Cable

Cable Model	Description
S6-L-T00-3.0	Servo drive to PC communication cable
S6-L-T01-0.3	Communication cable for multi-drive parallel connection
S6-L-T02-2.0	Servo drive to PLC communication cable
S6-L-T03-0.0	Plug for termination resistor for servo drive communication

1.5 Servo System Wiring

Figure 1-6 Wiring example of single-phase 220 V system

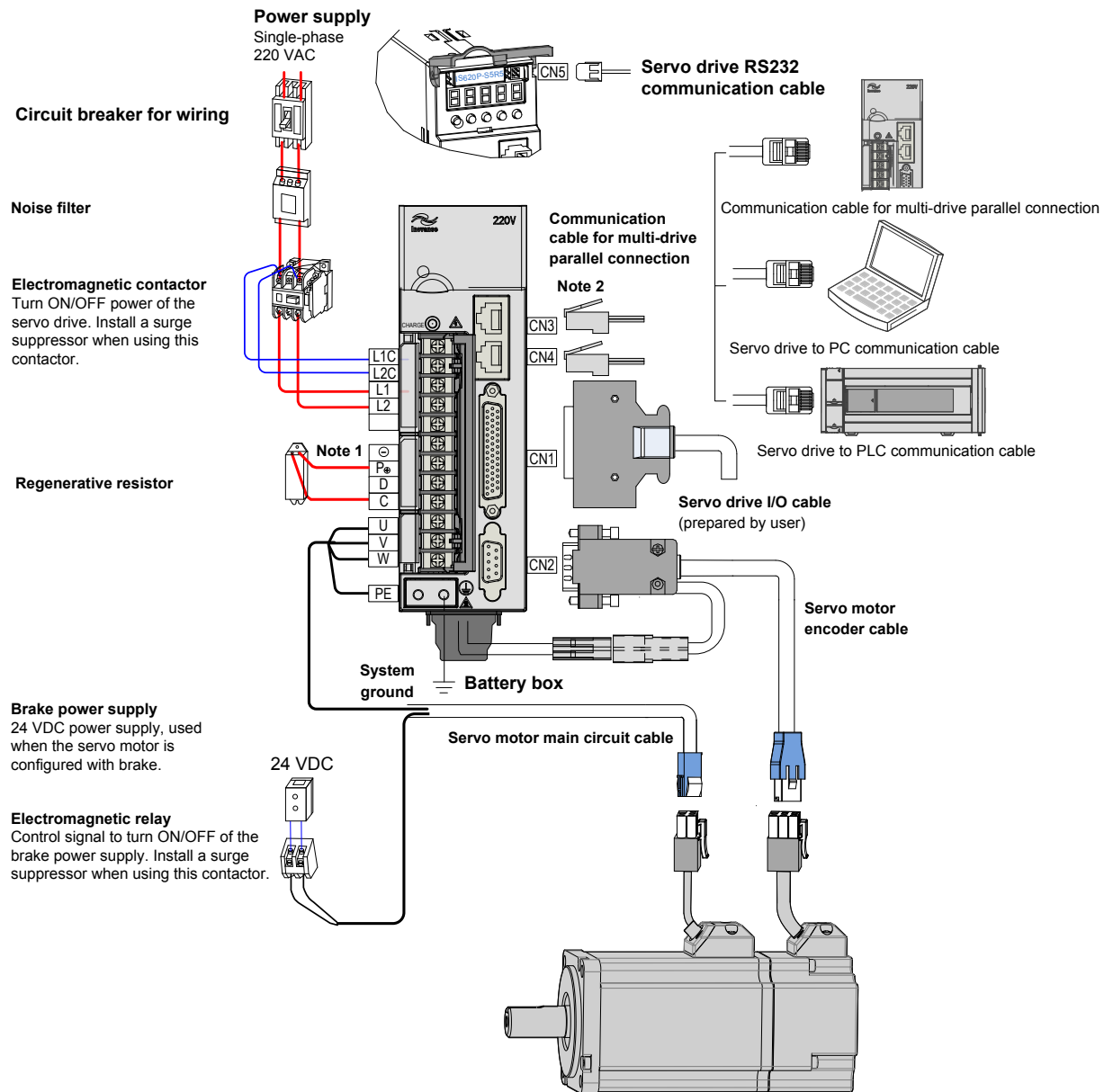

The servo drive is directly connected to an industrial power supply, with no isolation such as transformer. In this case, a fuse or circuit breaker must be connected on the input power supply to prevent cross electric accidents in the servo system. The servo drive is not configured with the built-

in protective grounding circuit. Thus, connect a residual current device (RCD) against both overload and short-circuit or a specialized RCCB combined with protective grounding.

It is forbidden to run or stop the motor by using the electromagnetic contactor. As a high-inductance device, the motor generates instantaneous high voltage, which may damage the contactor.

Pay attention to the power capacity when connecting an external control power supply or 24 VDC, especially when the power supply is for powering up multiple drives or brakes. Insufficient power supply will lead to lack of supply current, thus causing failure of the drives or brakes. The brake shall be powered up by a 24 VDC power supply. The power must match the motor model and meets the brake requirements.

Note	<ol style="list-style-type: none"> 1. Remove the jumper between terminals P_⊕ and D of the servo drive when connecting a regenerative resistor. 2. CN3 and CN4 are identical communication ports with the same pin definition, and either can be used.
-------------	--

Figure 1-7 Wiring example of three-phase 220 V/380 V system

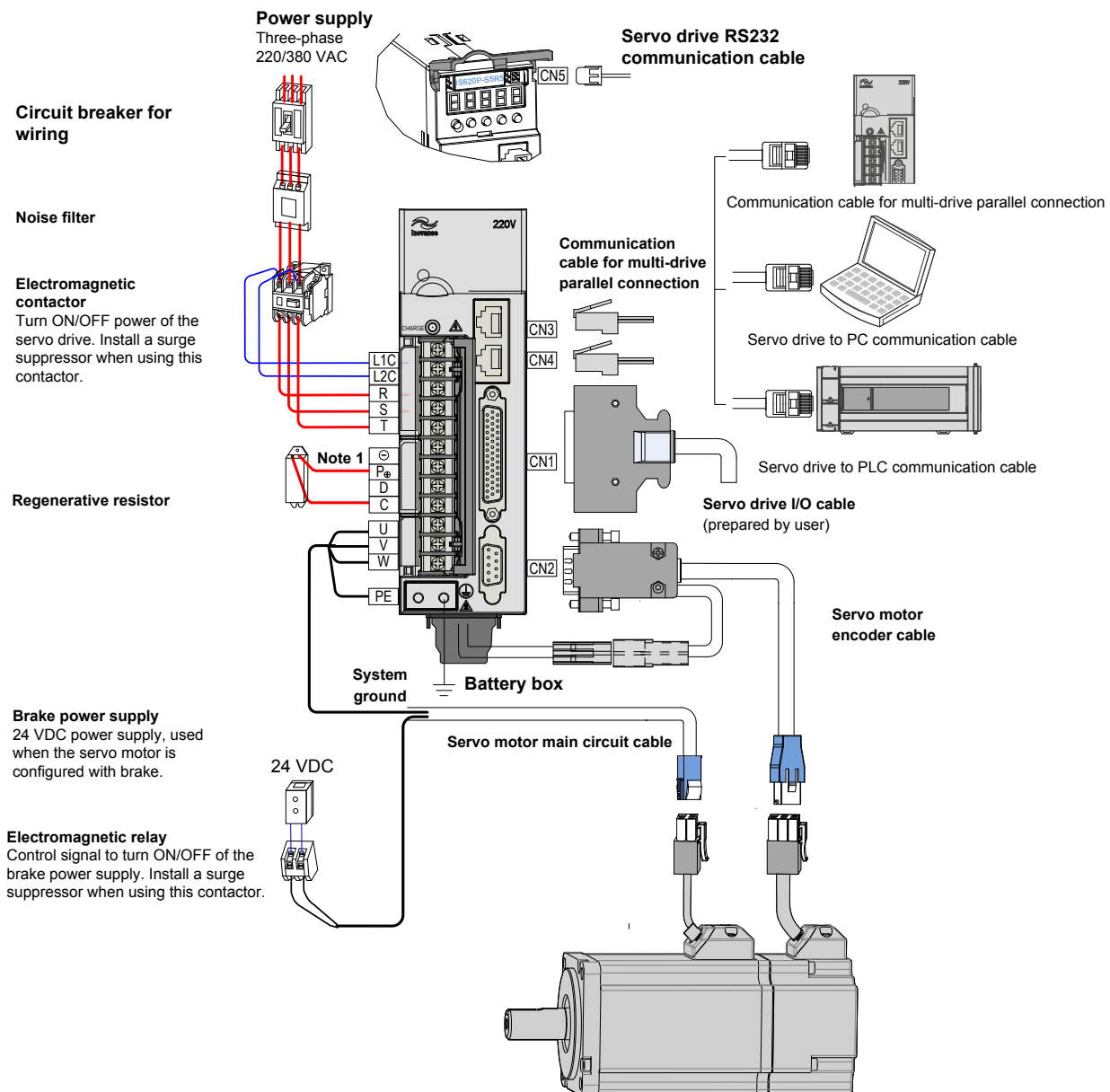

The servo drive is directly connected to an industrial power supply, with no isolation such as transformer. In this case, a fuse or circuit breaker must be connected on the input power supply to

prevent cross electric accidents in the servo system. The servo drive is not configured with the built-in protective grounding circuit. Thus, connect a RCD against both overload and short-circuit or a specialized RCD combined with protective grounding.

It is forbidden to run or stop the motor by using the electromagnetic contactor. As a high-inductance device, the motor generates instantaneous high voltage, which may damage the contactor.

Pay attention to the power capacity when connecting an external control power supply or 24 VDC, especially when the power supply is for powering up multiple drives or brakes. Insufficient power supply will lead to lack of supply current, thus causing failure of the drives or brakes. The brake shall be powered up by a 24 VDC power supply. The power must match the motor model and meets the brake requirements.

Note

1. Remove the jumper between terminals P_{\oplus} and D of the servo drive when connecting a regenerative resistor.
2. CN3 and CN4 are identical communication ports with the same pin definition, and either can be used.



2 Installation

2.1 Installation of Servo Drive	38
2.1.1 Installation Location	38
2.1.2 Installation Environment	38
2.1.3 Installation Precautions	38
2.2 Installation of Servo Motor	40
2.2.1 Installation Location	40
2.2.2 Installation Environment	40
2.2.3 Installation Precautions	41

Chapter 2 Installation

2.1 Installation of Servo Drive

2.1.1 Installation Location

- Install the servo drive inside a cabinet free from sun light and rain.
- Install the servo drive in an environment free from corrosive or inflammable gases or combustible goods, such as hydrogen sulfide, chlorine, ammonia, sulphur gas, chloridize gas, acid, soda and salt.
- Install the servo drive in an environment free from high temperature, moisture, dust and metal powder.
- Install the servo drive in a place with no vibration.
- The installation location must meet the pollution degree PD2.

2

2.1.2 Installation Environment

Table 2-1 Installation environment of servo drive

Item	Description
Use ambient temperature	0–55°C (average load ratio not exceeding 80% when ambient temperature is within 40–55°C) (no condensation)
Use environment humidity	Below 90% RH (no condensation)
Storage temperature	-20 to 85°C (non-freezing)
Storage humidity	Below 90% RH (no condensation)
Vibration	Below 4.9 m/s ²
Impact	Below 19.6 m/s ²
Degree of protection	IP10
Altitude	Below 1000 m

2.1.3 Installation Precautions

1) Installation method

Make sure the installation direction of the servo drive is vertical to the wall. Cool the servo drive with natural convection or via a cooling fan. Fix the servo drive securely on the mounting surface via two to four mounting holes (number of such mounting holes depends on the capacity of the servo drive).

Figure 2-1 Installation diagram of the servo drive

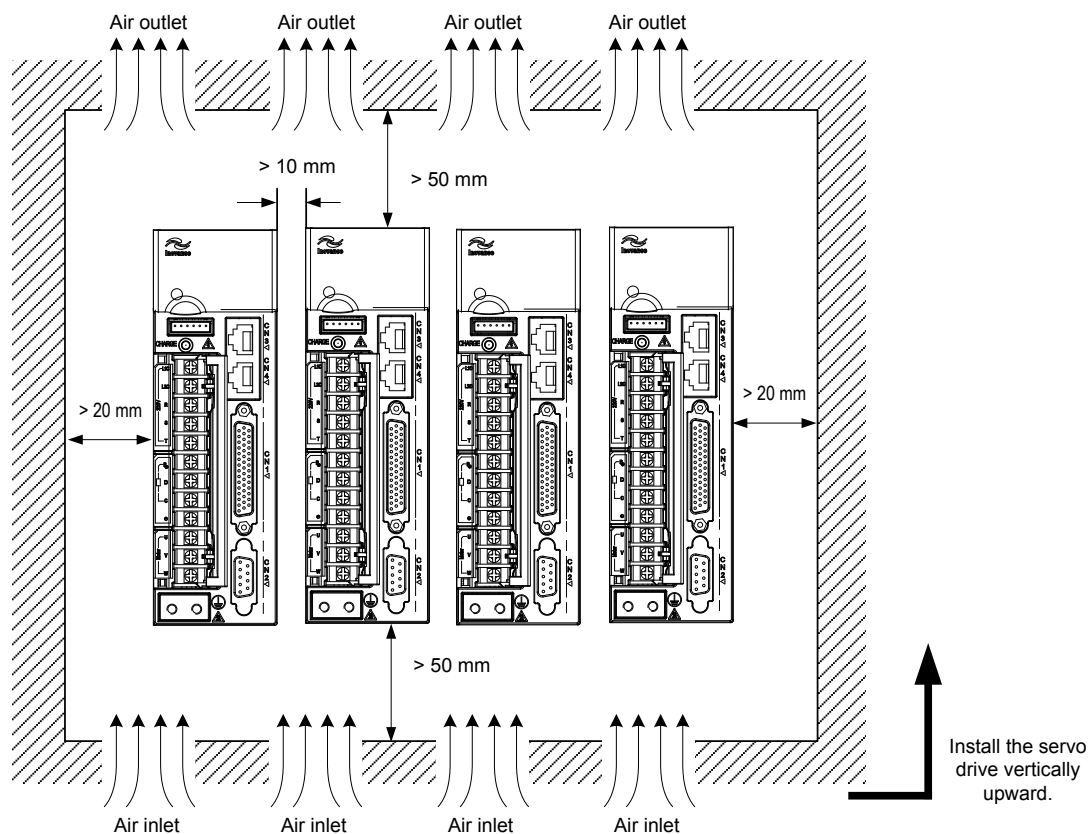

2

Install the servo drive vertical to the wall, making its front panel faces outward.

2) Cooling

As shown in the above figure, keep sufficient clearances around the servo drive to ensure cooling by cooling fans or natural convection. Install cooling fans above the servo drive to avoid excessive temperature rise and maintain even temperature inside the control cabinet.

3) Installation side by side

When installing multiple servo drives side by side, keep at least 10 mm between two servo drives (if installation space is limited, such clearance between servo drives can be ignored) and at least 50 mm above and below each servo drive.

4) Grounding

The grounding terminal must be properly grounded. Failure to comply may cause electric shock or malfunction due to interference.

5) Mount the drive with cable outlet facing downwards for water/oil countermeasure.

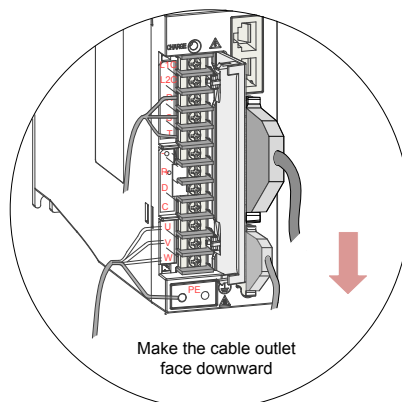

2.2 Installation of Servo Motor

2.2.1 Installation Location

- Install the servo motor in an environment free from corrosive or inflammable gases or combustible goods, such as hydrogen sulfide, chlorine, ammonia, sulphur gas, chloridize gas, acid, soda and salt.
- Use the servo motor with oil sealing when the motor is to be used in a place with grinding fluid, oil spray, iron powder or cuttings.
- Install the servo motor away from heat sources such as heating stove.
- Do not use the servo motor in an enclosed environment. Working in the enclosed environment will lead to high temperature of the servo motor, which will shorten its service life.

2.2.2 Installation Environment

2

Table 2-2 Installation environment of servo motor

Item	Description
Use ambient temperature	0 to 40°C (non-freezing)
Use environment humidity	20%–90% RH (no condensation)
Storage temperature	-20 to 60°C (Peak temperature ensurance: 80°C for 72 hours)
Storage humidity	20%–90% RH (no condensation)
Vibration	Below 49 m/s ²
Impact	Below 490 m/s ²
Degree of protection	H1/H4: IP65 (except for the through-shaft section and motor connectors) Other: IP67 (except for the through-shaft section and motor connectors)
Altitude	< 1000 m (de-rated if the altitude is above 1000 m)

2.2.3 Installation Precautions

Table 2-3 Installation precautions

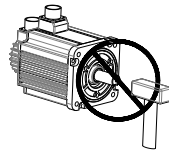
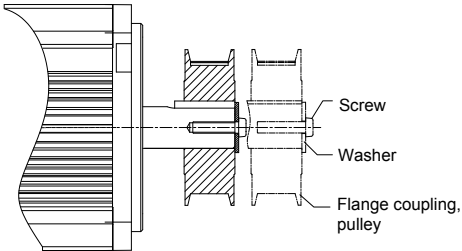
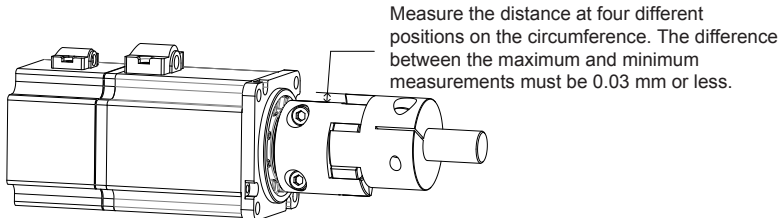
Item	Description
Rust-proof treatment	Wipe up the antirust agent at the motor shaft extension before installing the servo motor, and then take rust-proof treatment.
Encoder	<p>Do not strike the shaft extension during installation. Failure to comply will lead to damage to the internal encoder.</p> 
	<p>Use the screw hole at the shaft extension when mounting a pulley to the servo motor shaft with a keyway. To fit the pulley, insert a double-end screw into the screw hole of the shaft, put a washer against the coupling end, and then use a nut to push the pulley in.</p> <p>For the servo motor shaft without a keyway, use friction coupling or the like.</p> <p>When removing the pulley, use a pulley remover to protect the shaft from suffering severe impact from load.</p> <p>To ensure safety, install a protective cover or similar device on the rotary area such as the pulley mounted on the shaft.</p> 
Alignment	<p>Use the coupling for mechanical connection and align the axis of the servo motor with the axis of the equipment. When installing the servo motor, make sure that alignment accuracy satisfy the requirement as described in the following figure. If the axes are not properly aligned, vibration will be generated and may damage the bearings and encoder.</p> 
Installation direction	The servo motor can be installed horizontally or vertically.

2

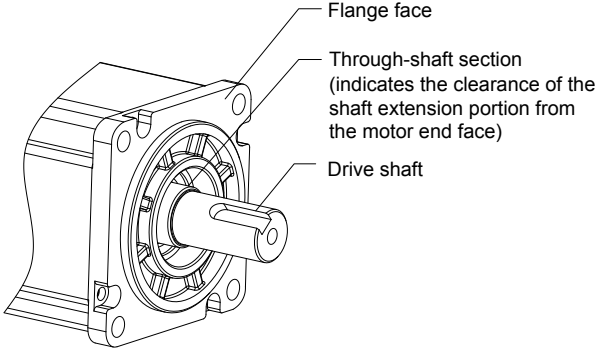
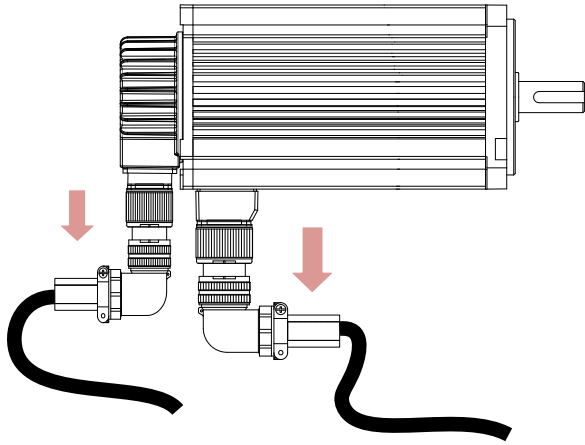
Item	Description
<p>Oil and moisture countermeasure</p>	<p>Do not submerge the motor/cable to water or oil.</p> <p>Confirm the IP level of the servo motor when using it in a place with water drops (except for the through-shaft section).</p>  <p>Flange face Through-shaft section (indicates the clearance of the shaft extension portion from the motor end face) Drive shaft</p> <p>Mount the motor with cable outlet facing downwards for water/oil countermeasure (as shown in the following figure).</p>  <p>In the environment where the through-shaft section is exposed to oil drops, use a servo motor with oil sealing.</p> <p>Observe the following conditions when using the servo motor with oil sealing:</p> <p>Make sure that the oil level is lower than the oil sealing lip during use.</p> <p>Prevent oil accumulation on the oil sealing lip when the motor is installed vertically upward.</p>
<p>Stress of cables</p>	<p>Do not bend or apply tension to the cables, especially the signal cables whose core wire is 0.2 or 0.3 mm thick. Do not pull the cables tightly during wiring.</p>

Item	Description
Connectors	<p>Observe the following precautions:</p> <p>When connecting the connectors, make sure that there is no waste or sheet metal inside the connectors.</p> <p>Connect the connectors to the power cable side of the servo motor first, and make sure that the grounding cable of the power cables is reliably connected. If the connectors are first connected to the encoder cable side, the encoder may become faulty due to the potential differences between PEs.</p> <p>Make sure the pins are correctly arranged during wiring.</p> <p>The connectors are made up of resins. Do not strike the connectors to prevent them from being damaged.</p> <p>Hold the servo motor body during transportation when the cables are well connected, instead of catching the cables. Otherwise, the connectors may be damaged or the cables may be broken.</p> <p>If bent cables are used, do not attach stress on the cables during wiring. Failure to comply may cause damage to the connectors.</p>



3 Wiring

3.1 Wiring of Servo Drive Main Circuit	49
3.2 Wiring of Motor Cables Between Servo Drive and Servo Motor	60
3.3 Wiring of Encoder Cables Between Servo Drive and Servo Motor	62
3.4 Wiring to Control Signal Terminal Connector CN1.....	71
3.5 Wiring to Communication Signal Terminal Connectors CN3/CN4.....	91
3.6 Wiring of Analog Monitoring Signal Terminal Connector CN5.....	97
3.7 Anti-interference Measures for Electrical Wiring.....	98
3.8 Precautions of Using Cables	101
3.9 Wiring of Three Control Modes	102

Chapter 3 Wiring



Wiring must be performed by authorized and qualified personnel.

Check the power indicator becomes off five minutes after turning off the power, and measure and check the voltage between P_⊕ and ⊖ by using a multimeter. Then, perform operations on the drive.

Perform wiring after the servo drive and motor are installed properly. Failure to comply will result in electric shock.

Do not damage the cables, lay them under large tension or pressure, or hang them. Failure to comply may result in electric shock.

Insulate the power terminal connectors to prevent electric shock.

The specifications and installation method of external cables must comply with the applicable local regulations.

The cables must be copper and the grounding cable must be yellow-green cable in Table 3-5.

Ensure the entire system is grounded.



Carry out wiring correctly. Failure to comply will result in abnormal action of the servo motor and even personal injury.

Do not mistake the terminal connection. Failure to comply may result in damage to the terminals.

Make sure to connect the electromagnetic contactor between the power supply and main circuit of the drive (L1, L2 for single-phase, R, S, T for three-phase). If no electromagnetic contactor is connected, a fire may occur when a fault occurs and continuous large current flows through the drive.

Use the ALM (fault signal) to cut off the main circuit power supply. When the braking transistor becomes faulty, the regenerative resistor may become overheat, causing a fire.

Before power-on, check the voltage specifications of the drive. NEVER connect the 380 V power supply to the 220 V drive. Failure to comply will damage the drive.

**CAUTION**

Do not reverse the directions of the flywheel diode. Failure to comply will damage the drive and affect signal output.

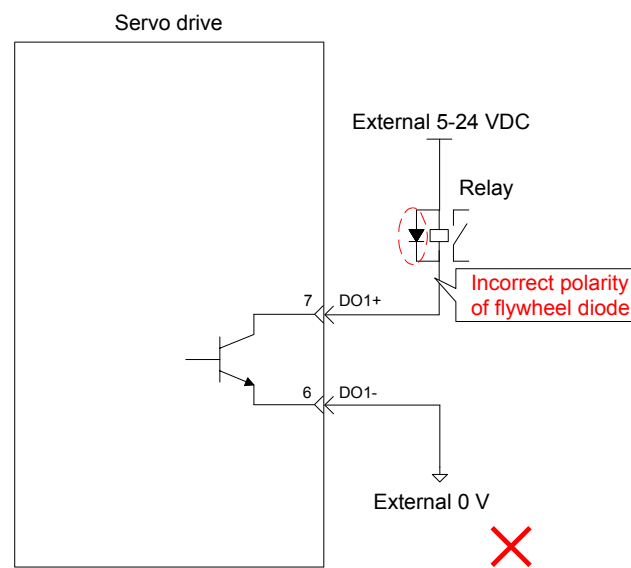

Use a noise filter to reduce electromagnetic interference on electronic devices around the drive.

For the power supply and main circuit connection, make sure that the main circuit power supply is cut off and the servo ON state changes to OFF state after the alarm signal is detected.

Connect U, V, W cables of the drive to U, V, W terminals of the motor directly. Do not connect an electromagnetic contactor. Failure to comply may result in abnormalities and faults.

Figure 3-1 Terminal arrangement of IS620P

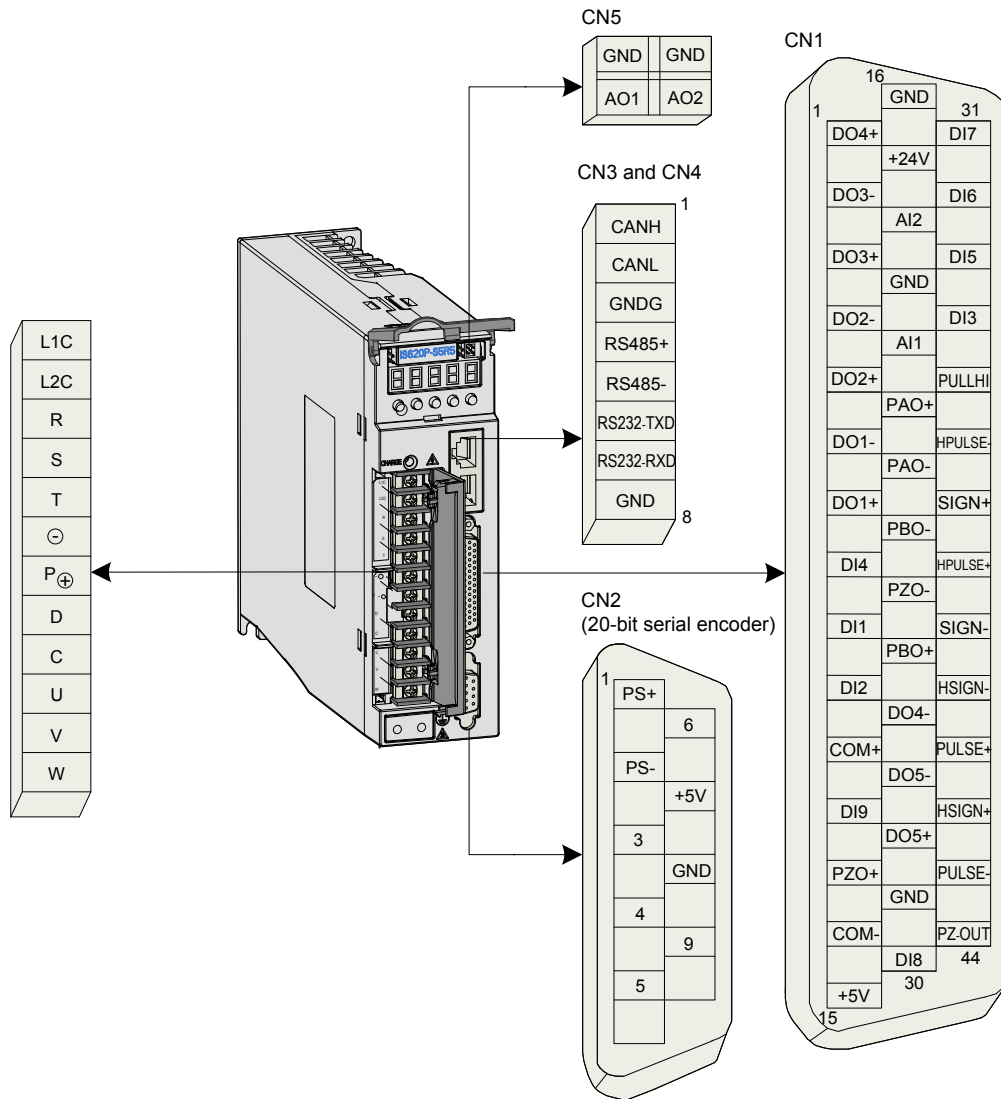

The preceding figure shows arrangement of the terminals in the servo drive.

3

3.1 Wiring of Servo Drive Main Circuit

3.1.1 Main Circuit Terminals

Figure 3-2 Terminal block arrangement of SIZE A (SIZE C)

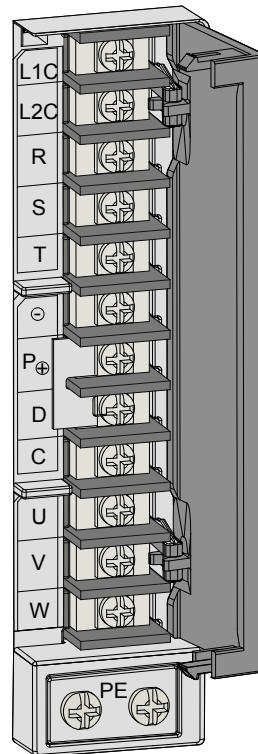

3

Table 3-1 Names and functions of main circuit terminals of SIZE A(SIZE C)

Terminal Symbol	Terminal Name	Terminal Function
L1, L2	Power input terminals	Single-phase power input. Connect 220 VAC power supply between L1 and L2 terminals.
R, S, T		Three-phase 220 V/380 V power input according to the nameplate.
L1C, L2C	Control power input terminals	Connect to control power input. For specific value, refer to the rated voltage on the nameplate.
P _⊕ , D, C	Terminals for connecting external regenerative resistor	Connect an external regenerative resistor between P _⊕ and C if the braking capacity is insufficient. The external regenerative resistor needs to be purchased additionally.
		Terminals P _⊕ and D are shorted by default. Remove the jumper between P _⊕ and D, and connect an external regenerative resistor between P _⊕ and C if the braking capacity is insufficient. The external regenerative resistor needs to be purchased additionally.
P _⊕ , ⊖	Common DC bus terminal	They are used for common DC bus connection when multiple servo drives are used in parallel.
U, V, W	Servo motor connection terminals	Connect to U, V and W phases of the servo motor.
PE	Ground	Two grounding terminals of the servo drive are respectively connected to those of the power supply and the servo motor. The entire system must be grounded.

Figure 3-3 Terminal block arrangement of SIZE E

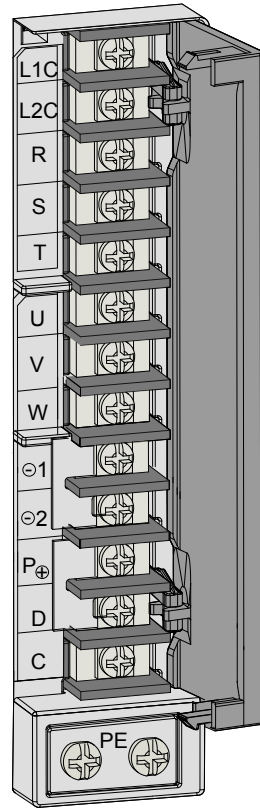

3

Table 3-2 Names and functions of main circuit terminals of SIZE E

Terminal Symbol	Terminal Name	Terminal Function
R, S, T	Main circuit power input terminals	Main circuit three-phase 380 V power input.
L1C, L2C	Control power input terminals	Connect to control power input. For specific value, refer to the rated voltage on the nameplate.
P _⊕ , D, C	Terminals for connecting external regenerative resistor	Terminals P _⊕ and D are shorted by default. Remove the jumper between P _⊕ and D, and connect an external regenerative resistor between P _⊕ and C if the braking capacity is insufficient. The external regenerative resistor needs to be purchased additionally.
P _⊕ , ⊖1 / ⊖2	Common DC bus terminal	They are used for common DC bus connection when multiple servo drives are used in parallel.
⊖1, ⊖2	Terminals for connecting external reactor	Terminals ⊖1 and ⊖2 are shorted by default. When the power harmonic current need to be restricted, remove the jumper and connect a reactor between ⊖1 and ⊖2 .
U, V, W	Servo motor connection terminals	Connect to U, V and W phases of the servo motor.
PE	Ground	Two grounding terminals of the servo drive are respectively connected to those of the power supply and the servo motor. The entire system must be grounded.

3.1.2 Examples of Regenerative Resistor Wiring

Figure 3-4 Connection diagram of external regenerative resistor

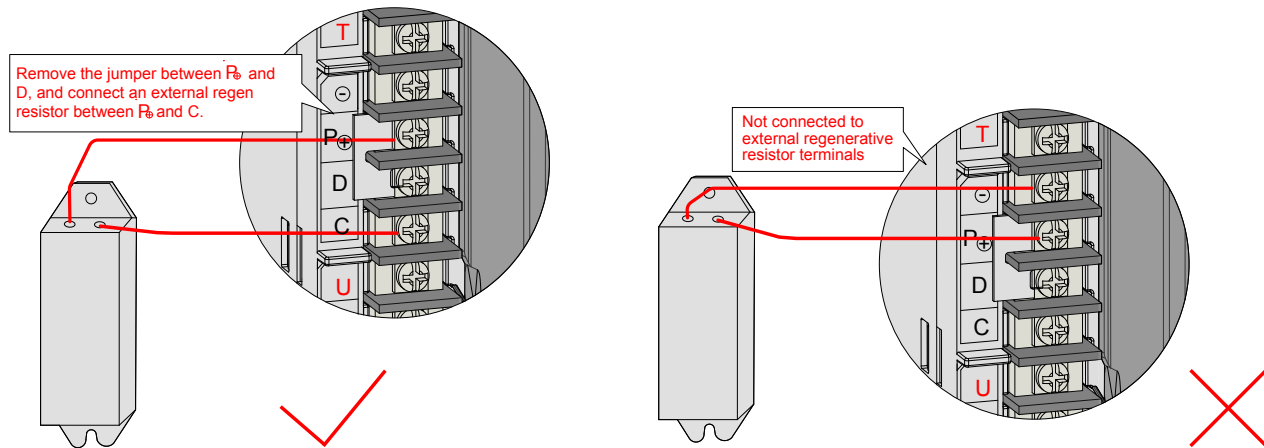

For details on selection and use of the regenerative resistor, refer to section 5.1.7.

Observe the following precautions when wiring the external regenerative resistor:



Do not directly connect the external regenerative resistor to the positive and negative poles of the bus P_{\oplus} and \ominus . Failure to comply will lead to damage of the servo drive or even cause a fire.

3

Remove the jumper between P_{\oplus} and D before using the external regenerative resistor. Failure to comply will cause overcurrent trip and thus damage the braking tube.

Do not select any resistor lower than the minimum resistance value. Failure to comply will result fault Er201 or damage to the servo drive.

Make sure that the parameters related to the regenerative resistor, H02-25, H02-26 and H02-27 are accurately set before using the servo drive.

Install the external regenerative resistor on incombustible objects (such as metal).

3.1.3 Recommended Models and Specifications of Power Cables

Figure 3-5 Dimension diagram of the servo drive terminal block

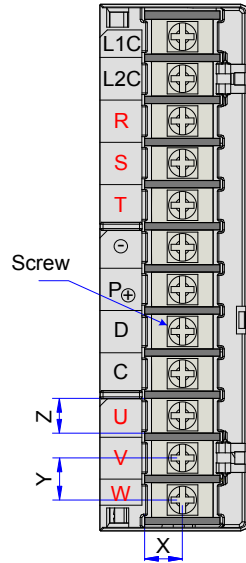

Table 3-3 Structural data of the terminal block

Structure	Main Circuit Terminals					PE Terminal	
	X (mm)	Y (mm)	Z (mm)	Screw	Tightening Torque (N·m)	Screw Size	Tightening Torque (N·m)
SIZE A	6.8	7.6	6.3	M3 combination screw	0.4–0.6	M4	0.6–1.2
SIZE C	8	8.2	7	M3 combination screw	0.4–0.6		
SIZE E	9	13	10	M4 combination screw	0.7–1.0		

Table 3-4 Rated current of the servo drive

Drive Model IS620P****I	Rated Input Current (A)	Rated Output Current (A)	Max. Output Current (A)
SIZE A	S1R6	2.3	1.6
	S2R8	4.0	2.8
	S5R5	7.9 (single-phase)/ 3.7(three-phase)	5.5
SIZE C	S7R6	5.1	7.6
	S012	8.0	11.6
	T3R5	2.4	3.5
	T5R4	3.6	5.4
	T8R4	5.6	8.4
	T012	8.0	11.9
SIZE E	T017	12.0	16.5
	T021	16.0	20.8
	T026	21.0	25.7

3

Table 3-5 Recommended power cable sizes of the servo drive

No.	Structure	Drive Model	Rated Input Current In	Recommended Input Power Cable		Rated Output Current	Recommended Output Power Cable		Recommended PE Cable	
				mm ²	AWG		mm ²	AWG	mm ²	AWG
Single-phase 220 V										
1	SIZE-A	IS620PS1R6I	2.30	2 x 0.5	20	1.60	2 x 0.5	20	0.50	20
2		IS620PS2R8I	4.00	2 x 0.5	20	2.80	2 x 0.5	20	0.50	20
3		IS620PS5R5I	7.90	2 x 0.75	18	5.50	2 x 0.75	18	0.75	18
Three-phase 220 V										
4	SIZE-A	IS620PS5R5I	3.70	3 x 0.5	20	5.50	3 x 0.5	20	0.50	20
5	SIZE-C	IS620PS7R6I	5.10	3 x 0.75	18	7.60	3 x 0.75	18	0.75	18
6		IS620PS012I	8.00	3 x 0.75	18	12.00	3 x 0.75	18	0.75	18
Three-phase 380 V										
7	SIZE-C	IS620PT3R5I	2.40	3 x 0.5	20	3.50	3 x 0.5	20	0.50	20
8		IS620PT5R4I	3.60	3 x 0.5	20	5.40	3 x 0.5	20	0.50	20
9		IS620PT8R4I	5.60	3 x 0.75	18	8.40	3 x 0.75	18	0.75	18
10		IS620PT012I	8.00	3 x 0.75	18	12.00	3 x 0.75	18	0.75	18
11	SIZE-E	IS620PT017I	12.00	3 x 1.5	14	17.00	3 x 1.5	14	1.50	14
12		IS620PT021I	16.00	3 x 2.5	12	21.00	3 x 2.5	12	2.50	12
13		IS620PT026I	21.00	3 x 4.0	10	26.00	3 x 4.0	10	4.00	10

3

Table 3-6 Recommended main circuit lugs for the servo drive

Drive Model IS620P****I		L1C, L2C	R, S, T	P _θ , C	U, V, W	PE
SIZE A	S1R6	TVR 1.25-3	TVR 1.25-3	TVR 1.25-3	TVR 1.25-3	TVR 2-4
		TVS 1.25-3	TVS 1.25-3	TVS 1.25-3	TVS 1.25-3	
	S2R8	TVR 1.25-3	TVR 1.25-3	TVR 1.25-3	TVR 1.25-3	TVR 2-4
	S5R5	TVR 1.25-3	TVR 1.25-3	TVR 1.25-3	TVR 1.25-3	TVR 2-4
		TVS 1.25-3	TVS 1.25-3	TVS 1.25-3	TVS 1.25-3	
SIZE C	S7R6	TVR 1.25-3	TVR 1.25-3	TVR 1.25-3	TVR 1.25-3	TVR 2-4
		TVS 1.25-3	TVS 1.25-3	TVS 1.25-3	TVS 1.25-3	
	S012	TVR 1.25-3	TVR 2-3M	TVR 2-3M	TVR 2-3M	TVR 2-4
		TVS 1.25-3	TVS 2-3W	TVS 2-3W	TVS 2-3W	
	T3R5	TVR 1.25-3	TVR 2-3M	TVR 2-3M	TVR 2-3M	TVR 2-4
		TVS 1.25-3	TVS 2-3W	TVS 2-3W	TVS 2-3W	
	T5R4	TVR 1.25-3	TVR 2-3M	TVR 2-3M	TVR 2-3M	TVR 2-4
		TVS 1.25-3	TVS 2-3W	TVS 2-3W	TVS 2-3W	
	T8R4	TVR 1.25-3	TVR 2-3M	TVR 2-3M	TVR 2-3M	TVR 2-4
		TVS 1.25-3	TVS 2-3W	TVS 2-3W	TVS 2-3W	

Drive Model IS620P****I		L1C, L2C	R, S, T	P ₀ , C	U, V, W	PE
SIZE C	T012	TVR 1.25-3 TVS 1.25-3	TVR 2-3M TVS 2-3W	TVR 2-3M TVS 2-3W	TVR 2-3M TVS 2-3W	TVR 2-4
SIZE E	T017	TVR 1.25-4 TVS 1.25-4W	TVR 5.5-4 TVS 5.5-4	TVR 5.5-4 TVS 5.5-4	TVR 5.5-4 TVS 5.5-4	TVR 5.5-4
	T021	TVR 1.25-4 TVS 1.25-4W	TVR 5.5-4 TVS 5.5-4	TVR 5.5-4 TVS 5.5-4	TVR 5.5-4 TVS 5.5-4	TVR 5.5-4
	T026	TVR 1.25-4 TVS 1.25-4W	TVR 5.5-4 TVS 5.5-4	TVR 5.5-4 TVS 5.5-4	TVR 5.5-4 TVS 5.5-4	TVR 5.5-4

The recommended lugs are manufactured by Suzhou Yuanli Metal Enterprise Co., Ltd.

Table 3-7 Sizes and appearance of cable lugs

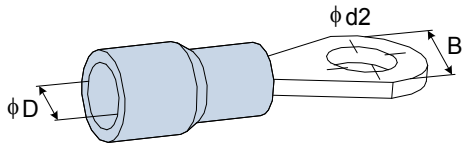
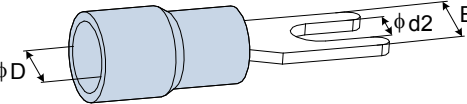
Lug Model		D (mm)	d2 (mm)	B (mm)	Appearance
TVR series	1.25-3	4.0	3.7	5.5	
	1.25-4	4.0	4.3	8.0	
	2-3M	4.5	3.7	6.6	
	2-4	4.5	4.3	8.5	
	5.5-3	6.3	3.7	9.5	
	5.5-4	6.3	4.3	9.5	
TVS series	1.25-3	4.0	3.2	5.7	
	1.25-4W	4.0	4.3	7.2	
	2-3W	4.5	3.7	6.2	
	5.5-3	6.3	3.2	7.3	
	5.5-4	6.3	4.3	8.2	

The following table describes the power cables.

Table 3-8 Recommended power cable types

Cable Type		Allowed Temperature (°C)
Model	Name	
PVC	General PVC cable	-
IV	600 V PVC cable	60
HIV	Special heat resistance PVC cable	75

The following table describes the relationship between the cable diameter and current for the preceding cable types. The actual value shall not exceed the value in the table.

3

Table 3-9 Cable specifications of recommended cable types

AWG Specifications	Nominal Sectional Area (mm ²)	Allowable Current in Different Ambient Temperatures (A)		
		30°C	40°C	50°C
20	0.519	8	7	6
19	0.653	9	8	7
18	0.823	13	11	9
16	1.31	18	15	12
14	2.08	26	23	20
12	3.31	32	28	26
10	5.26	48	43	38
8	8.37	70	65	55
6	13.3	95	85	75

3.1.4 Power Supply Wiring Example

1) Single-phase 220 V models: IS620PS1R6I and IS620PS2R8I

Figure 3-6 Main circuit wiring of single-phase 220 V servo drive

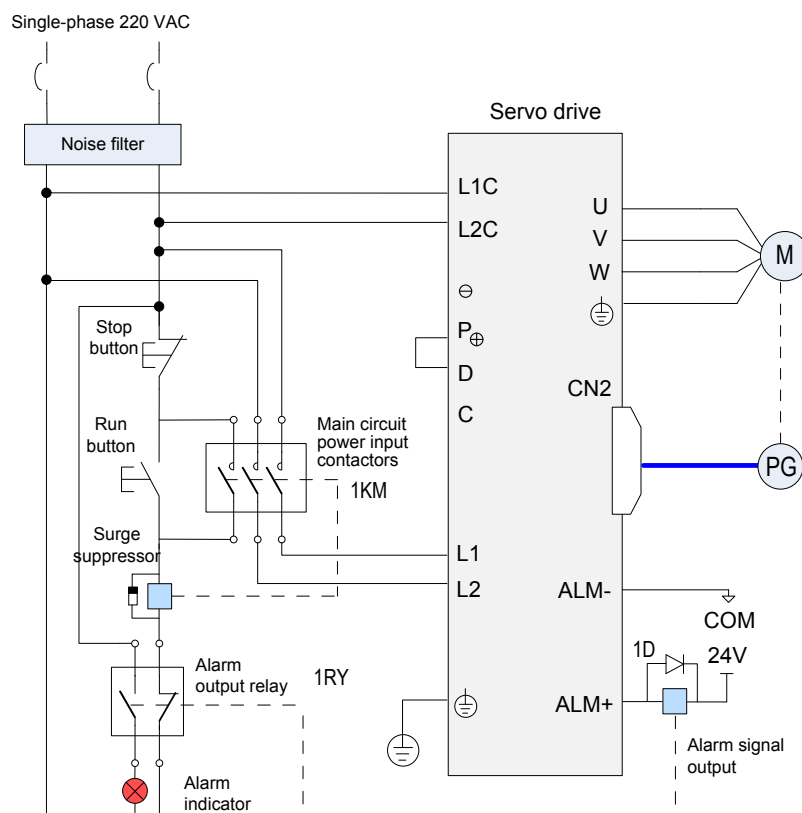

Note

- 1KM: electromagnetic contactor; 1RY: relay; 1D: flywheel diode
- DO4 is set as fault output (ALM+/-); when the servo drive alarms, the power supply is cut off automatically. The IS620PS1R6 and IS620PS2R8 do not have the built-in regenerative resistor, and therefore, P₊ and D need not be connected. Connect a regenerative resistor between P₊ and C if required.

2) Three-phase 220 V models: IS620PS5R5I, IS620PS7R6I, and IS620PS012I

Figure 3-7 Main circuit wiring of three-phase 220 V servo drive

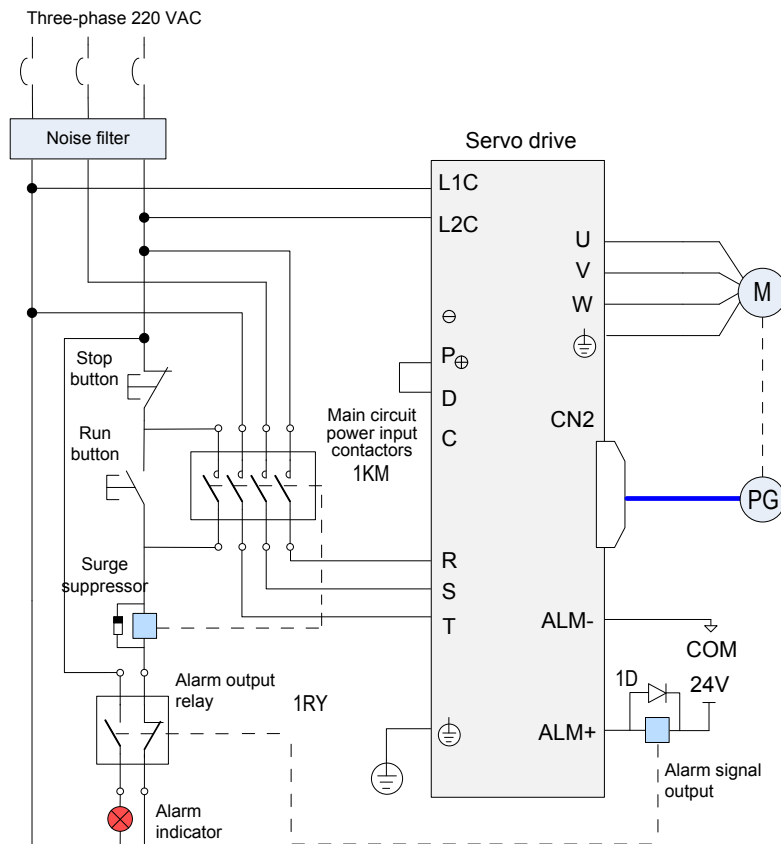

3

Note	1. 1KM: electromagnetic contactor; 1RY: relay; 1D: flywheel diode
	2. DO4 is set as fault output (ALM+/-); when the servo drive alarms, the power supply is cut off automatically and the alarm indicator becomes ON.

3) Three-phase 380 V models: IS620PT3R5I, IS620PT5R4I, IS620PT8R4I, IS620PT012I

Figure 3-8 Main circuit wiring of three-phase 380 V servo drive

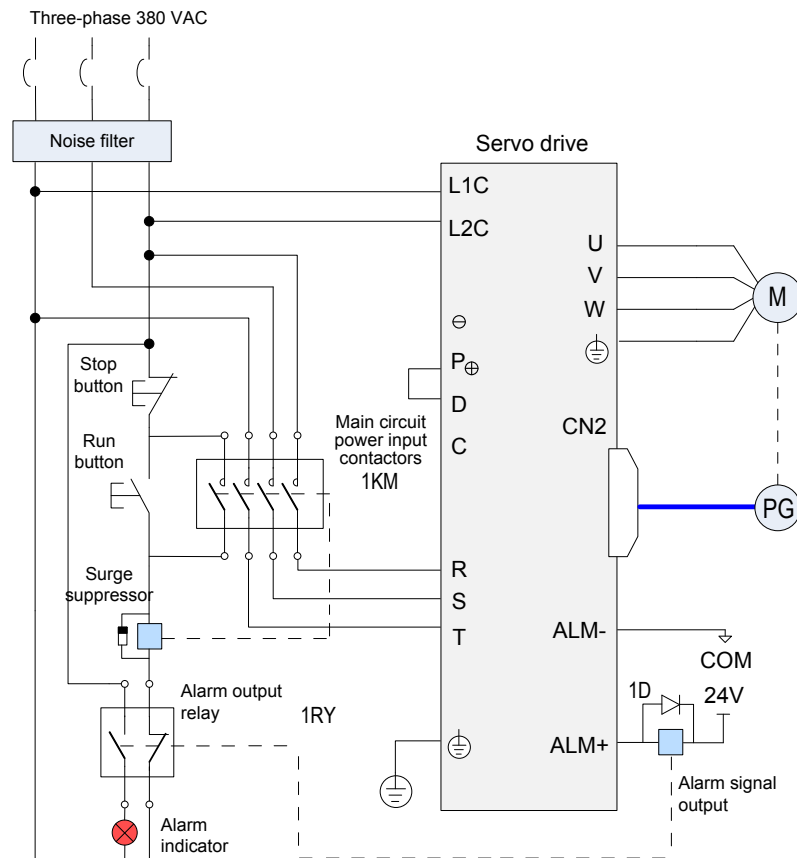
**Note**

1. 1KM: electromagnetic contactor; 1RY: relay; 1D: flywheel diode
2. DO4 is set as fault output (ALM+/-); when the servo drive alarms, the power supply is cut off automatically and the alarm indicator becomes ON.

4) Three-phase 380 V models: IS620PT017I, IS620PT021I, IS620PT026I

Figure 3-9 Main circuit wiring of three-phase 380 V servo drive

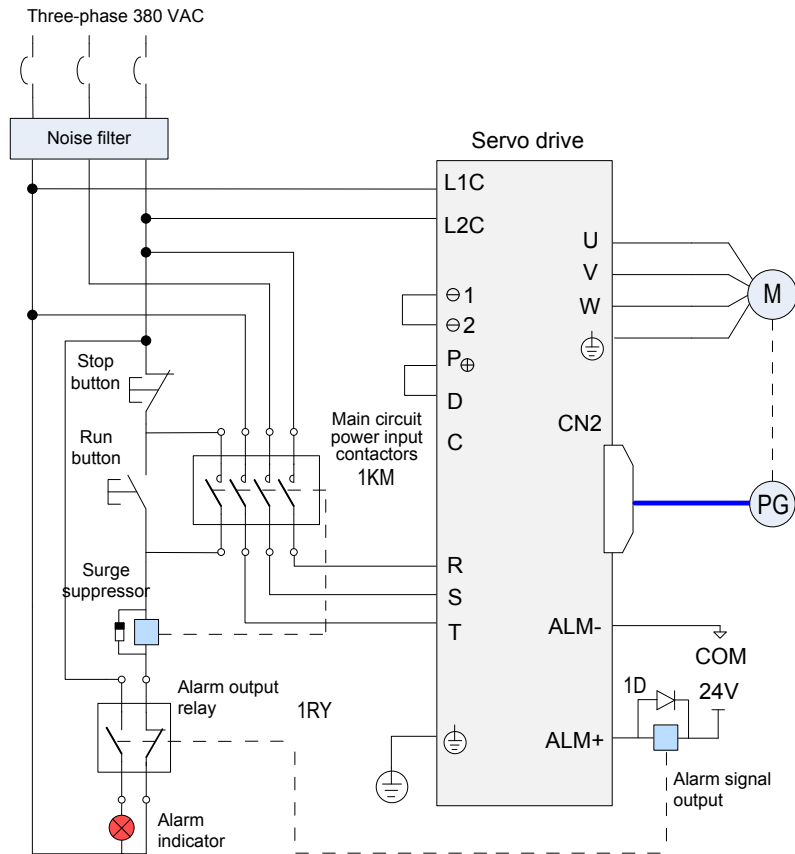

3

Note	1. 1KM: electromagnetic contactor; 1RY: relay; 1D: flywheel diode
	2. DO4 is set as fault output (ALM+/-); when the servo drive alarms, the power supply is cut off automatically and the alarm indicator becomes ON.

3.1.5 Precautions for Main Circuit Wiring

Do not connect the input power cables to the output terminals U, V and W. Failure to comply will cause damage to the servo drive.

If the built-in regenerative resistor is used, P_⊕ and D must be shorted (they are shorted with a jumper at delivery).

⊖1 and ⊖2 are shorted with a jumper by default. When the high order harmonics need to be restricted, remove the jumper and connect a DC reactor between ⊖1 and ⊖2.

When cables are bundled in a duct, take current reduction into consideration since the cooling condition becomes poor.

Ordinary cables become quickly aged in high temperature environment and easily sclerotic and broken in low temperature environment. Thus, use heat resistance cables in high temperature environment and take heat preservation measures in low temperature environment.

The bending radius of a cable shall exceed 10 times that of its outer diameter to prevent the internal wire core from breaking due to long time bending.

Select and use cables of rated voltage above 600 VAC and rated temperature above 75°C. Under the 30°C ambient temperature and normal cooling conditions, the permissible current density of the

cables shall not exceed 8 A/mm^2 when the total current is below 50 A, or 5 A/mm^2 when the total current is above 50 A. This value can be adjusted when the ambient temperature is high or when the cables are bundled. The permissible current density (A/mm^2) is calculated as follow:

Allowable current density = $8 \times$ Current reduction coefficient of conductor \times Current augmenting coefficient

$$\text{Current augmenting coefficient} = \sqrt{(\text{Max. allowable temperature of cable} - \text{Ambient temperature})/30}$$

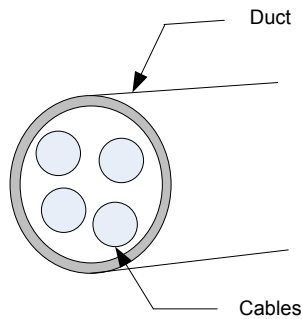

Current reduction coefficient of conductor

Number of Cables in the Same Duct	Current Reduction Coefficient
≤ 3	0.7
4	0.63
5 to 6	0.56
7 to 15	0.49

- Do not connect the regenerative resistor between terminals P_{\oplus} and \ominus . Failure to comply may cause a fire.
- Do not bundle power cables and signal cables together or run them through the same duct. Power and signal cables must be separated by at least 30 cm to prevent interference.
- High residual voltage may still remain in the servo drive when the power supply is cut off. Do not touch the power terminals within 5 minutes after power-off.
- Do not frequently turn ON and OFF the power supply. If the power supply needs to be turned on or off repeatedly, make sure that the time interval is at least one minute. The servo drive contains a capacitor in the power supply, and a high charging current flows for 0.2 seconds when the power supply is turned OFF. Frequently turning ON and OFF the power supply will deteriorate performance of the main circuit components inside the servo drive.
- Use a grounding cable with the same cross-sectional area as the power cable. If the cross-sectional area of the power cable is less than 1.6 mm^2 , use a grounding cable with a cross-sectional area of 2.0 mm^2 .
- Ground the servo drive reliably.
- Do not power on the servo drive when any screw of the terminal block or any cable becomes loose. Otherwise, a fire may occur.

3

3.1.6 Specifications of Main Circuit Peripheral Parts

The circuit breaker and electromagnetic contactor are recommended.

Table 3-10 Recommended circuit breaker and electromagnetic contactor models

Main Circuit Power Supply	Drive Model	Recommended Circuit Breaker		Recommended Contactor	
		Current (A)	Schneider Model	Current (A)	Schneider Model
Single-phase 220 V	IS620PS1R6I	4	OSMC32N3C4	9	LC1 D09
	IS620PS2R8I	6	OSMC32N3C6	9	LC1 D09
	IS620PS5R5I	16	OSMC32N3C16	9	LC1 D09

Main Circuit Power Supply	Drive Model	Recommended Circuit Breaker		Recommended Contactor	
		Current (A)	Schneider Model	Current (A)	Schneider Model
Three-phase 220 V	IS620PS5R5I	6	OSMC32N3C6	9	LC1 D09
	IS620PS7R6I	10	OSMC32N3C10	9	LC1 D09
	IS620PS012I	16	OSMC32N3C16	9	LC1 D09
Three-phase 380 V	IS620PT3R5I	4	OSMC32N3C4	9	LC1 D09
	IS620PT5R4I	6	OSMC32N3C6	9	LC1 D09
	IS620PT8R4I	10	OSMC32N3C10	9	LC1 D09
	IS620PT012I	16	OSMC32N3C16	9	LC1 D09
	IS620PT017I	20	OSMC32N3C20	12	LC1 D12
	IS620PT021I	25	OSMC32N3C25	18	LC1 D18
	IS620PT026I	32	OSMC32N3C32	25	LC1 D25

3.2 Wiring of Motor Cables Between Servo Drive and Servo Motor

Figure 3-10 Example of connecting servo drive and servo motor

3

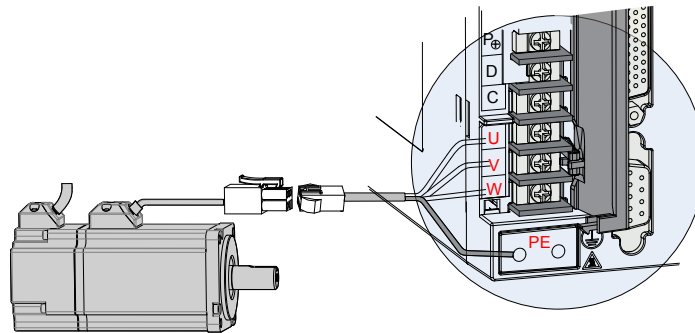
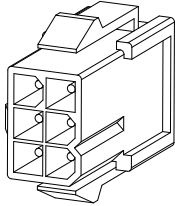
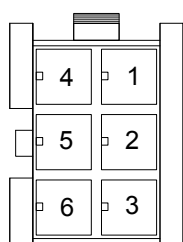
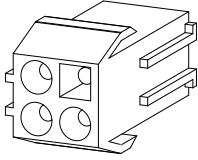
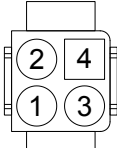
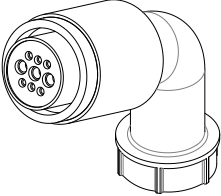
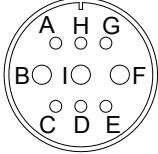
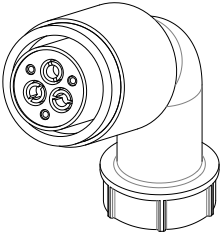
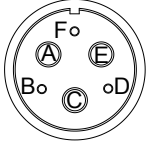

Table 3-11 Connectors of cables on servo motor side

Connector Appearance	Pin Layout	Frame Size of Matching Motor																			
	<p>Black 6-pin connector</p>  <table border="1"> <thead> <tr> <th>Pin No.</th> <th>Signal</th> <th>Color</th> </tr> </thead> <tbody> <tr> <td>1</td> <td>U</td> <td>White</td> </tr> <tr> <td>2</td> <td>V</td> <td>Black</td> </tr> <tr> <td>4</td> <td>W</td> <td>Red</td> </tr> <tr> <td>5</td> <td>PE</td> <td>Yellow/ Green</td> </tr> <tr> <td>3</td> <td rowspan="2">Brake (regardless of positive or negative)</td> <td></td> </tr> <tr> <td>6</td> </tr> </tbody> </table>	Pin No.	Signal	Color	1	U	White	2	V	Black	4	W	Red	5	PE	Yellow/ Green	3	Brake (regardless of positive or negative)		6	<p>40 (Z series) 60 (Z series) 80 (Z series)</p>
	Pin No.	Signal	Color																		
1	U	White																			
2	V	Black																			
4	W	Red																			
5	PE	Yellow/ Green																			
3	Brake (regardless of positive or negative)																				
6																					
<p>Recommendation: Plastic housing: MOLEX-50361736 Terminal: MOLEX-39000061</p>																					

Connector Appearance	Pin Layout	Frame Size of Matching Motor																																							
	<p>4-pin connector</p>  <table border="1" data-bbox="826 435 1225 640"> <thead> <tr> <th>Pin No.</th> <th>Signal</th> <th>Color</th> </tr> </thead> <tbody> <tr> <td>1</td> <td>U</td> <td>Blue</td> </tr> <tr> <td>2</td> <td>V</td> <td>Black</td> </tr> <tr> <td>3</td> <td>W</td> <td>Red</td> </tr> <tr> <td>4</td> <td>PE</td> <td>Yellow/Green</td> </tr> </tbody> </table> <p>Recommendation:</p> <p>Plastic housing: EL-4A (CWB) Terminal: 421.6003.0 (CWB)</p>	Pin No.	Signal	Color	1	U	Blue	2	V	Black	3	W	Red	4	PE	Yellow/Green	<p>40 (X series) 60 (X series) 80 (X series)</p>																								
Pin No.	Signal	Color																																							
1	U	Blue																																							
2	V	Black																																							
3	W	Red																																							
4	PE	Yellow/Green																																							
	<p>MIL-DTL-5015 series 3108E20-18S military spec. 20-18 military spec.</p>  <table border="1" data-bbox="586 1105 1305 1464"> <thead> <tr> <th colspan="2">New Structure</th> <th colspan="2">Old Structure</th> <th rowspan="2">Color</th> </tr> <tr> <th>Pin No.</th> <th>Signal</th> <th>Pin No.</th> <th>Signal</th> </tr> </thead> <tbody> <tr> <td>B</td> <td>U</td> <td>B</td> <td>U</td> <td>Blue</td> </tr> <tr> <td>I</td> <td>V</td> <td>I</td> <td>V</td> <td>Black</td> </tr> <tr> <td>F</td> <td>W</td> <td>F</td> <td>W</td> <td>Red</td> </tr> <tr> <td>G</td> <td>PE</td> <td>G</td> <td>PE</td> <td>Yellow/ Green</td> </tr> <tr> <td>C</td> <td rowspan="2">Brake (regardless of positive or negative)</td> <td></td> <td></td> <td></td> </tr> <tr> <td>E</td> <td></td> <td></td> <td></td> </tr> </tbody> </table>	New Structure		Old Structure		Color	Pin No.	Signal	Pin No.	Signal	B	U	B	U	Blue	I	V	I	V	Black	F	W	F	W	Red	G	PE	G	PE	Yellow/ Green	C	Brake (regardless of positive or negative)				E				<p>100 130</p>	
New Structure		Old Structure		Color																																					
Pin No.	Signal	Pin No.	Signal																																						
B	U	B	U	Blue																																					
I	V	I	V	Black																																					
F	W	F	W	Red																																					
G	PE	G	PE	Yellow/ Green																																					
C	Brake (regardless of positive or negative)																																								
E																																									
	<p>MIL-DTL-5015 series 3108E20-22S military spec. 20-22 military spec.</p>  <table border="1" data-bbox="605 1777 1286 2133"> <thead> <tr> <th colspan="2">Y Series</th> <th colspan="2">Z Series</th> <th rowspan="2">Color</th> </tr> <tr> <th>Pin No.</th> <th>Signal</th> <th>Pin No.</th> <th>Signal</th> </tr> </thead> <tbody> <tr> <td>A</td> <td>U</td> <td>A</td> <td>U</td> <td>Blue</td> </tr> <tr> <td>C</td> <td>V</td> <td>C</td> <td>V</td> <td>Black</td> </tr> <tr> <td>E</td> <td>W</td> <td>E</td> <td>W</td> <td>Red</td> </tr> <tr> <td>F</td> <td>PE</td> <td>F</td> <td>PE</td> <td>Yellow/ Green</td> </tr> <tr> <td>D</td> <td></td> <td>B</td> <td rowspan="2">Brake (regardless of positive or negative)</td> <td></td> </tr> <tr> <td></td> <td></td> <td></td> <td></td> <td></td> </tr> </tbody> </table>	Y Series		Z Series		Color	Pin No.	Signal	Pin No.	Signal	A	U	A	U	Blue	C	V	C	V	Black	E	W	E	W	Red	F	PE	F	PE	Yellow/ Green	D		B	Brake (regardless of positive or negative)							<p>180</p>
Y Series		Z Series		Color																																					
Pin No.	Signal	Pin No.	Signal																																						
A	U	A	U	Blue																																					
C	V	C	V	Black																																					
E	W	E	W	Red																																					
F	PE	F	PE	Yellow/ Green																																					
D		B	Brake (regardless of positive or negative)																																						

Note	<p>1. Frame size of motor: indicates the width of motor flange.</p> <p>2. The motor cable colors are subject to the actual. The cable colors mentioned in the manual are all Inovance cables.</p>
-------------	---

3.3 Wiring of Encoder Cables Between Servo Drive and Servo Motor

3.3.1 Connection of Serial Incremental Encoder

Figure 3-11 Example of connecting encoder signal cables

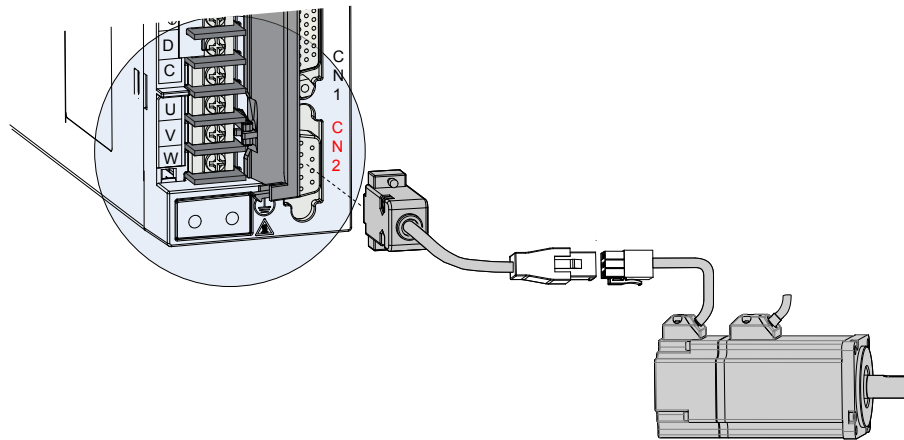

3

Note	The encoder cable colors are subject to the actual. The cable colors mentioned in the manual are all Inovance cables.
-------------	---

Table 3-12 Connectors of 20-bit encoder cables on servo drive side

Connector Appearance	Pin Layout												
	<div style="display: flex; align-items: center;"> <table border="1" style="margin-left: 20px;"> <thead> <tr> <th>Pin No.</th> <th>Signal</th> </tr> </thead> <tbody> <tr> <td>1</td> <td>PS+</td> </tr> <tr> <td>2</td> <td>PS-</td> </tr> <tr> <td>7</td> <td>+5V</td> </tr> <tr> <td>8</td> <td>GND</td> </tr> <tr> <td>Housing</td> <td>PE</td> </tr> </tbody> </table> </div> <p>Recommendation: Plastic housing of plug on cable side: DB9P (SZTDK), black housing Core: DB9P soldering plug (SZTDK), blue glue</p>	Pin No.	Signal	1	PS+	2	PS-	7	+5V	8	GND	Housing	PE
Pin No.	Signal												
1	PS+												
2	PS-												
7	+5V												
8	GND												
Housing	PE												

Table 3-13 Connectors of 20-bit encoder cables (9-pin connector)

Connector Appearance and Pin Layout		Frame Size of Matching Motor																																	
 <p>Encoder cable connector</p> <p>Connect to CN2 of the drive</p>	 <p>Encoder cable connector</p>	<p>40 60 80</p>																																	
 <p>Viewed from this side</p> <table border="1"> <thead> <tr> <th>Pin No.</th> <th>Signal</th> <th></th> </tr> </thead> <tbody> <tr> <td>3</td> <td>PS+</td> <td rowspan="2">Twisted-pair</td> </tr> <tr> <td>6</td> <td>PS-</td> </tr> <tr> <td>9</td> <td>+5V</td> <td></td> </tr> <tr> <td>8</td> <td>GND</td> <td></td> </tr> <tr> <td>7</td> <td>Shield</td> <td></td> </tr> </tbody> </table> <p>Recommendation: Plastic housing: AMP 172161-1 Terminal: AMP 770835-1</p>	Pin No.		Signal		3	PS+	Twisted-pair	6	PS-	9	+5V		8	GND		7	Shield		 <p>Viewed from this side</p> <table border="1"> <thead> <tr> <th>Pin No.</th> <th>Signal</th> <th>Color</th> </tr> </thead> <tbody> <tr> <td>3</td> <td>PS+</td> <td>Yellow</td> </tr> <tr> <td>6</td> <td>PS-</td> <td>Blue</td> </tr> <tr> <td>9</td> <td>+5V</td> <td>White</td> </tr> <tr> <td>8</td> <td>GND</td> <td rowspan="2">Red</td> </tr> <tr> <td>7</td> <td>Shield</td> </tr> </tbody> </table>	Pin No.	Signal	Color	3	PS+	Yellow	6	PS-	Blue	9	+5V	White	8	GND	Red	7
Pin No.	Signal																																		
3	PS+	Twisted-pair																																	
6	PS-																																		
9	+5V																																		
8	GND																																		
7	Shield																																		
Pin No.	Signal	Color																																	
3	PS+	Yellow																																	
6	PS-	Blue																																	
9	+5V	White																																	
8	GND	Red																																	
7	Shield																																		

Table 3-14 Connectors of 20-bit encoder cables (MIL-DTL-5015 series 3108E20-29S military spec. plug)

Connector Appearance and Pin Layout		Frame Size of Matching Motor																																								
 <p>Encoder cable connector</p> <p>Connect to CN2 of the drive</p>		 <p>Encoder connection socket</p>																																								
 <p>20-29 military spec.</p> <p>Viewed from this side</p>			<p>100</p> <p>130</p> <p>180</p>																																							
<table border="1"> <thead> <tr> <th>Pin No.</th> <th>Signal</th> <th></th> </tr> </thead> <tbody> <tr> <td>A</td> <td>PS+</td> <td rowspan="2">Twisted-pair</td> </tr> <tr> <td>B</td> <td>PS-</td> </tr> <tr> <td>G</td> <td>+5V</td> <td></td> </tr> <tr> <td>H</td> <td>GND</td> <td></td> </tr> <tr> <td>J</td> <td>Shielded</td> <td></td> </tr> </tbody> </table>		Pin No.	Signal		A	PS+	Twisted-pair	B	PS-	G	+5V		H	GND		J	Shielded		<table border="1"> <thead> <tr> <th>Pin No.</th> <th>Signal</th> <th>Color</th> <th></th> </tr> </thead> <tbody> <tr> <td>A</td> <td>PS+</td> <td>Yellow</td> <td rowspan="2">Twisted-pair</td> </tr> <tr> <td>B</td> <td>PS-</td> <td>Blue</td> </tr> <tr> <td>G</td> <td>+5V</td> <td>White</td> <td></td> </tr> <tr> <td>H</td> <td>GND</td> <td>Red</td> <td></td> </tr> <tr> <td>J</td> <td>Shielded</td> <td></td> <td></td> </tr> </tbody> </table>	Pin No.	Signal	Color		A	PS+	Yellow	Twisted-pair	B	PS-	Blue	G	+5V	White		H	GND	Red		J	Shielded		
Pin No.	Signal																																									
A	PS+	Twisted-pair																																								
B	PS-																																									
G	+5V																																									
H	GND																																									
J	Shielded																																									
Pin No.	Signal	Color																																								
A	PS+	Yellow	Twisted-pair																																							
B	PS-	Blue																																								
G	+5V	White																																								
H	GND	Red																																								
J	Shielded																																									

3

Table 3-15 Pin connection relation of IS620P series 20-bit encoder cables

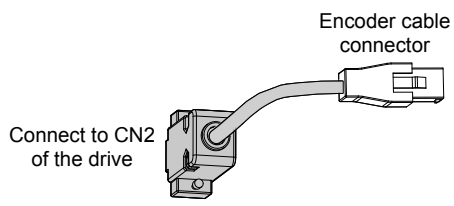
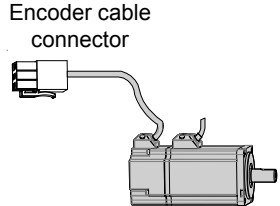
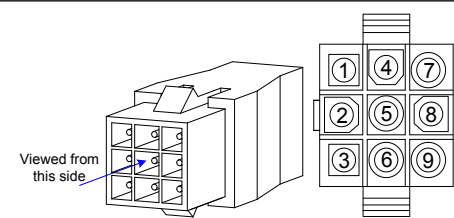
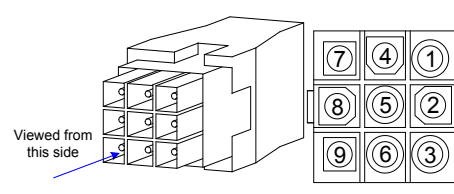
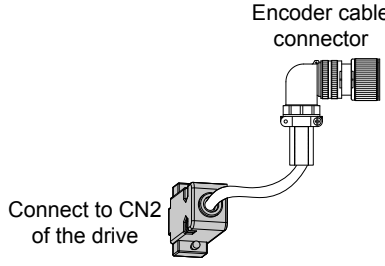
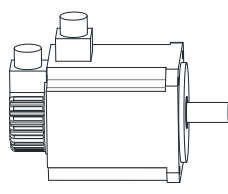
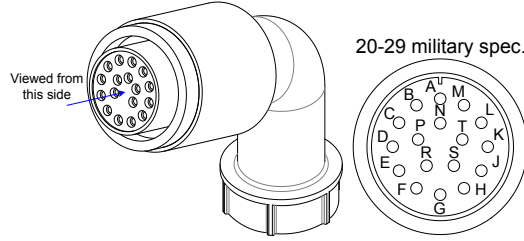
DB9 on Servo Drive Side		Function Description	Motor Side	
Signal	Pin No.		9-pin Pin No.	20-29 Military Spec. Pin No.
PS+	1	Serial communication signal +	3	A
PS-	2	Serial communication signal -	6	B
+5V	7	Encoder +5V power supply	9	G
GND	8	Encoder +5V power ground	8	H
PE	Housing	Shield	7	J

Observe the following precautions when wiring the encoder:

- Ground the servo drive and shielded layer of the servo motor reliably. Otherwise, the servo drive will report a false alarm.
- Do not connect cables to the reserved pins.
- To determine the length of the encoder cable, consider voltage drop caused by the cable resistance and signal attenuation caused by the distributed capacitance. It is recommended

to use twisted-pair cable of size 26AWG or above (as per UL2464 standard) and with a length within 10 m.

Note	It is recommended that the 22AWG to 26AWG cables and matching AMP170359-1 connectors be used for the 10B, 20B, 40B, and 75B series motors. If the cable length is very large, use the cable of a larger size, as described in the following table.
-------------	--

Table 3-16 Recommended cable sizes

Cable Size	Ω/km	Allowed Cable Length (m)
26AWG (0.13 mm ²)	143	10.0
25AWG (0.15 mm ²)	89.4	16.0
24AWG (0.21 mm ²)	79.6	18.0
23AWG (0.26 mm ²)	68.5	20.9
22AWG (0.32 mm ²)	54.3	26.4

Note	If the cables of above 22AWG are required, contact Inovance.
-------------	--

3.3.2 Installation of Absolute Encoder

1. Installation of the battery box for the absolute encoder

Battery box model (option): S6-C4

This option includes:

- Sheet metal bracket
- Plastic box body
- 3.6 V/2600 mAh battery
- 2 M3x10 flat-head screw
- 1 M3x10 pan-head screw
- Terminal block and crimping terminal

Installing the battery box

The following figure shows the installation and connection procedure of the battery box.

Figure 3-12 Installation diagram of battery box for absolute encoder

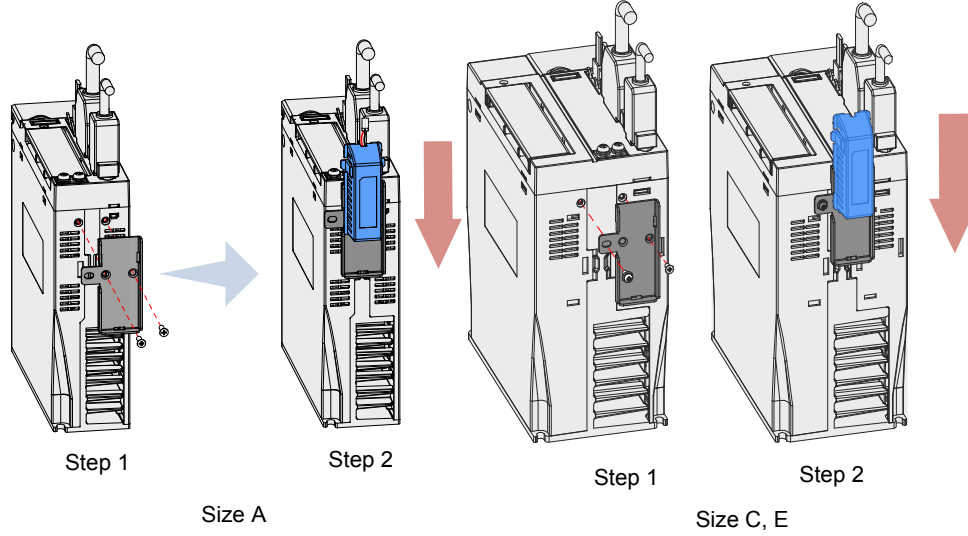

Fasten the battery box with two flat-head screws for size A models and one flat-head screw plus one pan-head screw for size C and E models. The flat-head screw is fixed into the flat-head slot.

3

Removing the battery box

The battery may have leakage after a long-time use. Replace it every two years.

Remove the battery box in steps reverse to those in the preceding figure.

When closing the battery box cover, prevent the connector cables from being pinched.

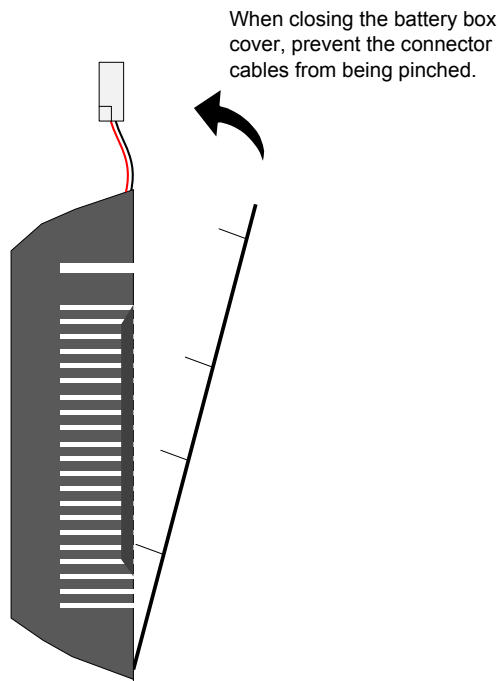



If the battery is used improperly, it may result in battery leakage which corrodes the components or causes battery explosion. Observe the following precautions during use:

- Insert the battery with correct +/- polarity.
- Leaving a battery that has been used for a long time use or is no longer useful inside the device can cause battery leakage. The electrolyte inside the battery is highly corrosive, not only corroding surrounding components but also give rise to the danger of short circuit. Replace the battery periodically (recommended period: every 2 years).
- Do not disassemble the battery as fragments of the interior parts may fly into your eyes, which is extremely dangerous.
- Do not throw a battery into the fire as this may cause the battery to rupture.
- Prevent battery short circuit, and do not strip the battery tube. It is dangerous for metal items to make contact with the electrodes of the battery, as such objects may cause a high current to flow, weakening the battery power and probably causing rupture of the battery due to severe heating.
- This battery is not rechargeable.
- Dispose the battery according to local regulations.

Selecting battery

Select an appropriate according to the following table.

Table 3-17 Battery description for absolute encoder

Battery Spec.	Item	Rating			Condition
		Min.	Common	Max.	
Output: 3.6 V, 2500 mAh	External battery voltage (V)	3.2	3.6	5	In standby mode (Note 2)
	Circuit fault voltage (V)		2.6		In standby mode
	Battery alarm voltage (V)	2.85	3	3.15	
Recommended manufacturer and model: Shezhen Jieshun, LS14500	Battery consumption circuit (uA)		2		During normal operation (Note 1)
			10		In standby mode, axis static
			80		In standby mode, axis rotating
	Battery use temperature (°C)	0		40	Same as motor ambient temperature
Battery storage temperature (°C)	-20		60		

The preceding data is measured in the 20°C ambient temperature.

Note	<p>1. During normal operation, the absolute encoder supports one-turn or multi-turn data counting and transmitting/receiving. After connecting the absolute encoder properly, turn on the power to the servo drive, and the encoder enters normal operation state and transmits/receives data after a delay of 5s.</p> <p>When the encoder switches from standby state to normal operation state (power turned on), the motor speed must not exceed 10 RPM. Otherwise, the servo drive reports Er.740, and you need to power on the servo drive again.</p> <p>2. Standby state: The servo drive is not powered on, and the external battery is used for multi-turn data counting. In this case, data transmitting/receiving is not performed.</p>
-------------	---

Battery service life

The calculation must be based on not only the encoder's current consumption and also the battery consumption itself.

Assume that:

Normal operation time of servo drive: T1

Motor rotating time after power-off of servo drive: T2

Motor rotating stop time after power-off: T3 (unit: hour)

Table 3-18 Battery service life of absolute encoder in theory

Item	Time Arrangement 1	Time Arrangement 2
Days in one year (days)	313	52
T1 (hour)	8	0
T2 (hour)	0.1	0
T3 (hour)	15.9	24

Yearly consumption = $(8\text{H} \times 2\mu\text{A} + 0.1\text{H} \times 80\mu\text{A} + 15.9\text{H} \times 10\mu\text{A}) \times 313 + (0\text{H} \times 2\mu\text{A} + 0\text{H} \times 80\mu\text{A} + 24\text{H} \times 10\mu\text{A}) \times 52 \approx 70 \text{ mAH}$

Battery service life in theory = Battery capacity/Yearly consumption = $2600 \text{ mAH}/70 \text{ mAH} = 37.1$ years

2. Wiring of battery box and signal wires

Figure 3-13 Signal and battery wiring example of absolute encoder

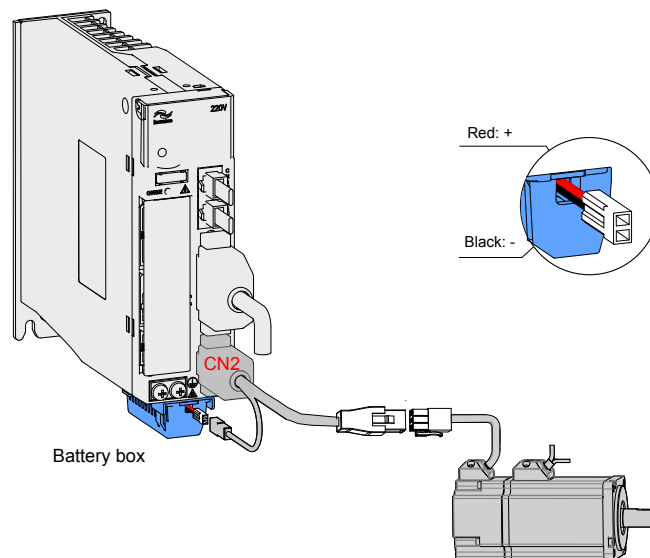

Note

Store the battery box in required ambient temperature and ensure the battery is in reliable contact and has sufficient capacity. Otherwise, position information loss may occur in the encoder.

3. Connectors of absolute encoder cables on servo motor side

Table 3-19 Connectors of absolute encoder cables (9-pin connector)

Connector Appearance and Pin Layout		Frame Size of Matching Motor																																											
 <p>Encoder cable connector</p> <p>Connect to CN2 of the drive</p>	 <p>Encoder cable connector</p>	<p>40 60 80</p>																																											
 <p>Viewed from this side</p> <table border="1" data-bbox="361 1011 755 1336"> <thead> <tr> <th>Pin No.</th> <th>Signal</th> <th></th> </tr> </thead> <tbody> <tr> <td>1</td> <td>Battery+</td> <td rowspan="7" style="text-align: center; vertical-align: middle;">Twisted-pair</td> </tr> <tr> <td>4</td> <td>Battery-</td> </tr> <tr> <td>3</td> <td>PS+</td> </tr> <tr> <td>6</td> <td>PS-</td> </tr> <tr> <td>9</td> <td>+5V</td> </tr> <tr> <td>8</td> <td>GND</td> </tr> <tr> <td>7</td> <td>Shield</td> </tr> </tbody> </table> <p>Recommendation: Plastic housing: AMP 172161-1 Terminal: AMP 770835-1</p>	Pin No.		Signal		1	Battery+	Twisted-pair	4	Battery-	3	PS+	6	PS-	9	+5V	8	GND	7	Shield	 <p>Viewed from this side</p> <table border="1" data-bbox="824 1035 1310 1432"> <thead> <tr> <th>Pin No.</th> <th>Signal</th> <th>Color</th> <th></th> </tr> </thead> <tbody> <tr> <td>1</td> <td>Battery+</td> <td>Blue</td> <td rowspan="7" style="text-align: center; vertical-align: middle;">Twisted-pair</td> </tr> <tr> <td>4</td> <td>Battery-</td> <td>Blue black</td> </tr> <tr> <td>3</td> <td>PS+</td> <td>Yellow</td> </tr> <tr> <td>6</td> <td>PS-</td> <td>Yellow black</td> </tr> <tr> <td>9</td> <td>+5V</td> <td>Red</td> </tr> <tr> <td>8</td> <td>GND</td> <td>Black</td> </tr> <tr> <td>7</td> <td>Shield</td> <td></td> </tr> </tbody> </table>	Pin No.	Signal	Color		1	Battery+	Blue	Twisted-pair	4	Battery-	Blue black	3	PS+	Yellow	6	PS-	Yellow black	9	+5V	Red	8	GND	Black	7	Shield
Pin No.	Signal																																												
1	Battery+	Twisted-pair																																											
4	Battery-																																												
3	PS+																																												
6	PS-																																												
9	+5V																																												
8	GND																																												
7	Shield																																												
Pin No.	Signal	Color																																											
1	Battery+	Blue	Twisted-pair																																										
4	Battery-	Blue black																																											
3	PS+	Yellow																																											
6	PS-	Yellow black																																											
9	+5V	Red																																											
8	GND	Black																																											
7	Shield																																												

Table 3-20 Connectors of absolute encoder cables (MIL-DTL-5015 series 3108E20-29S military spec. plug)

Connector Appearance and Pin Layout		Frame Size of Matching Motor																																																		
																																																				
	<p>20-29 military spec.</p> 		<p>100</p> <p>130</p> <p>180</p>																																																	
<table border="1" data-bbox="361 1095 760 1420"> <thead> <tr> <th>Pin No.</th> <th>Signal</th> <th></th> </tr> </thead> <tbody> <tr> <td>A</td> <td>PS+</td> <td rowspan="2">Twisted-pair</td> </tr> <tr> <td>B</td> <td>PS-</td> </tr> <tr> <td>E</td> <td>Battery+</td> <td rowspan="2"></td> </tr> <tr> <td>F</td> <td>Battery-</td> </tr> <tr> <td>G</td> <td>+5V</td> <td rowspan="2"></td> </tr> <tr> <td>H</td> <td>GND</td> </tr> <tr> <td>J</td> <td>Shield</td> <td></td> </tr> </tbody> </table>	Pin No.	Signal		A	PS+	Twisted-pair	B	PS-	E	Battery+		F	Battery-	G	+5V		H	GND	J	Shield		<table border="1" data-bbox="824 1078 1328 1464"> <thead> <tr> <th>Pin No.</th> <th>Signal</th> <th>Color</th> <th></th> </tr> </thead> <tbody> <tr> <td>A</td> <td>PS+</td> <td>Yellow</td> <td rowspan="2">Twisted-pair</td> </tr> <tr> <td>B</td> <td>PS-</td> <td>Yellow black</td> </tr> <tr> <td>E</td> <td>Battery+</td> <td>Blue</td> <td rowspan="2"></td> </tr> <tr> <td>F</td> <td>Battery-</td> <td>Blue black</td> </tr> <tr> <td>G</td> <td>+5V</td> <td>Red</td> <td rowspan="2"></td> </tr> <tr> <td>H</td> <td>GND</td> <td>Black</td> </tr> <tr> <td>J</td> <td>Shield</td> <td></td> <td></td> </tr> </tbody> </table>	Pin No.	Signal	Color		A	PS+	Yellow	Twisted-pair	B	PS-	Yellow black	E	Battery+	Blue		F	Battery-	Blue black	G	+5V	Red		H	GND	Black	J	Shield			
Pin No.	Signal																																																			
A	PS+	Twisted-pair																																																		
B	PS-																																																			
E	Battery+																																																			
F	Battery-																																																			
G	+5V																																																			
H	GND																																																			
J	Shield																																																			
Pin No.	Signal	Color																																																		
A	PS+	Yellow	Twisted-pair																																																	
B	PS-	Yellow black																																																		
E	Battery+	Blue																																																		
F	Battery-	Blue black																																																		
G	+5V	Red																																																		
H	GND	Black																																																		
J	Shield																																																			

3.4 Wiring to Control Signal Terminal Connector CN1

Figure 3-14 Pin layout of control circuit terminal connector of servo drive

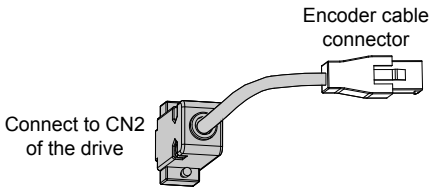
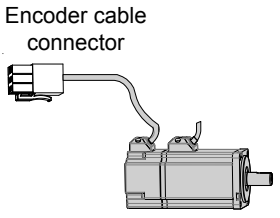
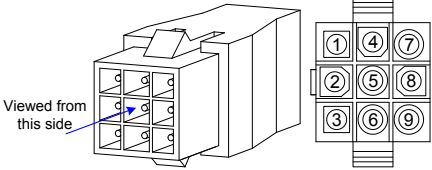
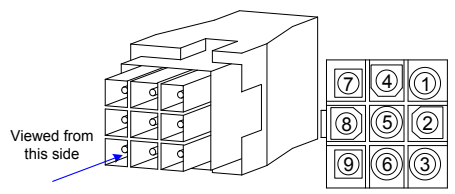
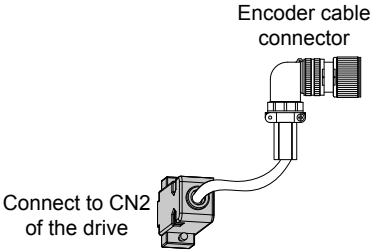
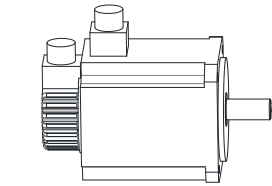
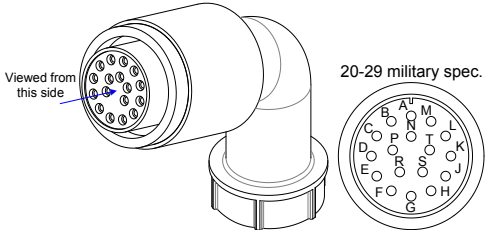
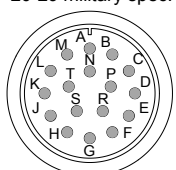
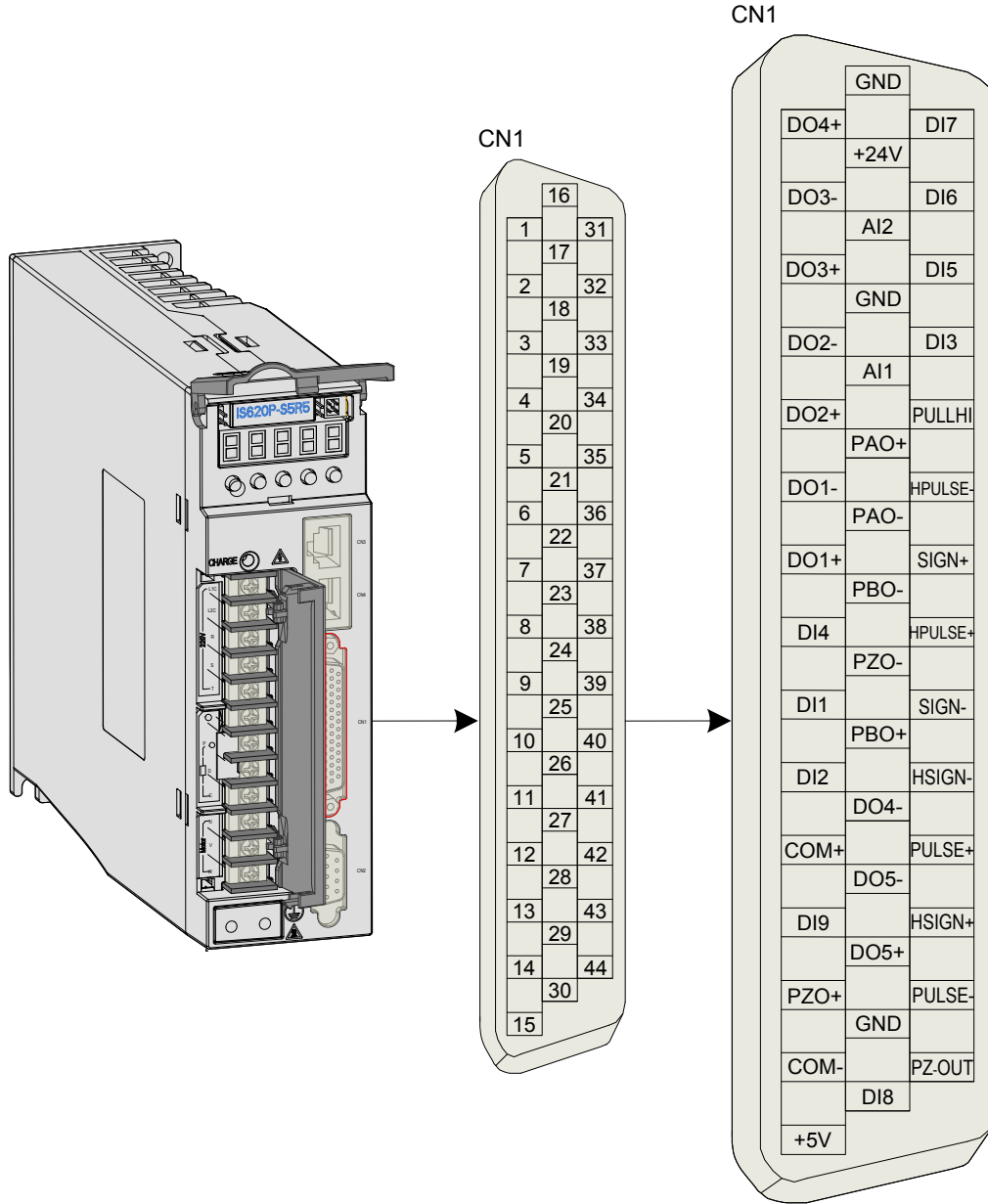

CN1 terminal: Plastic housing of plug on cable side: DB25P (SZTDK), black housing; Core: HDB44P (SZTDK), soldering plug

Note The 24AWG to 26AWG cables are recommended.

Figure 3-15 Wiring of three control modes

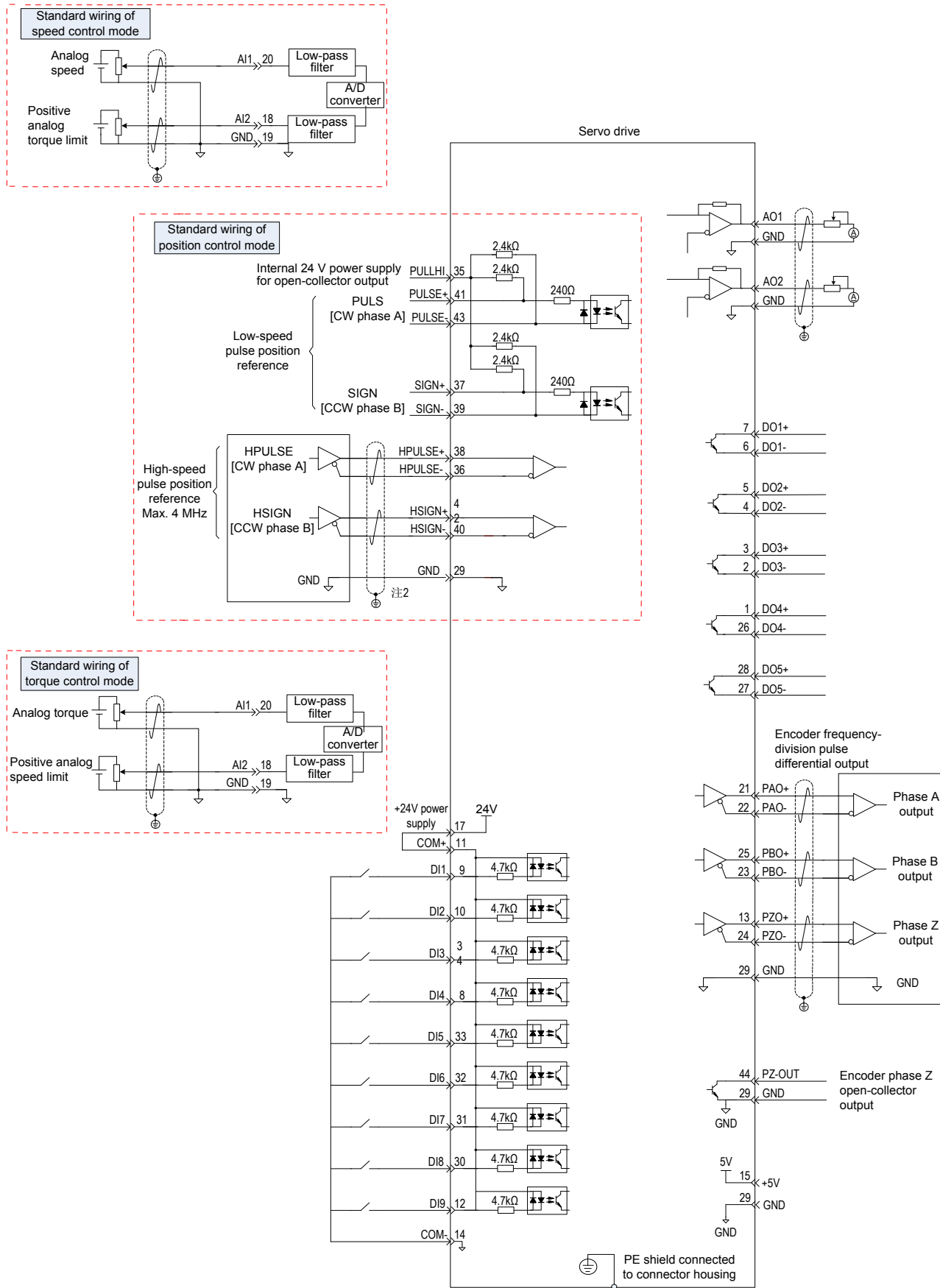

3

3.4.1 Position Reference Input Signals

Table 3-21 Position reference signal description

Signal		Pin No.	Function Description	
Position reference	PULSE+	41	Low-speed pulse input mode	Pulse input format:
	PULSE-	43		Direction + Pulse
	SIGN+	37	Differential drive mode OC mode	Phase A + B quadrature pulse
	SIGN-	39		CW/CCW pulse
	HPULSE+	38	High-speed reference pulse input	
	HPULSE-	36		
	HSIGN+	42	High-speed position reference symbols	
	HSIGN-	40		
PULLHI	35	External power input terminal of reference pulse		
GND	29	Signal ground		

The reference pulse and symbol signal output circuit on the host controller side can either be differential drive output or OC output. The following table lists the maximum input frequency and minimum pulse width of these output modes.

Table 3-22 Correspondence between pulse input frequency and pulse width

Pulse Mode		Max. Frequency (pps)	Min. Pulse Width (us)
Low speed	Differential	500 k	1
	OC	200 k	2.5
High-speed differential		4 M	0.125

Note	If the output pulse width of the host controller is smaller than the minimum value, a pulse receiving error occurs in the servo drive.
-------------	--

1) Low-speed pulse input

a. Differential drive mode

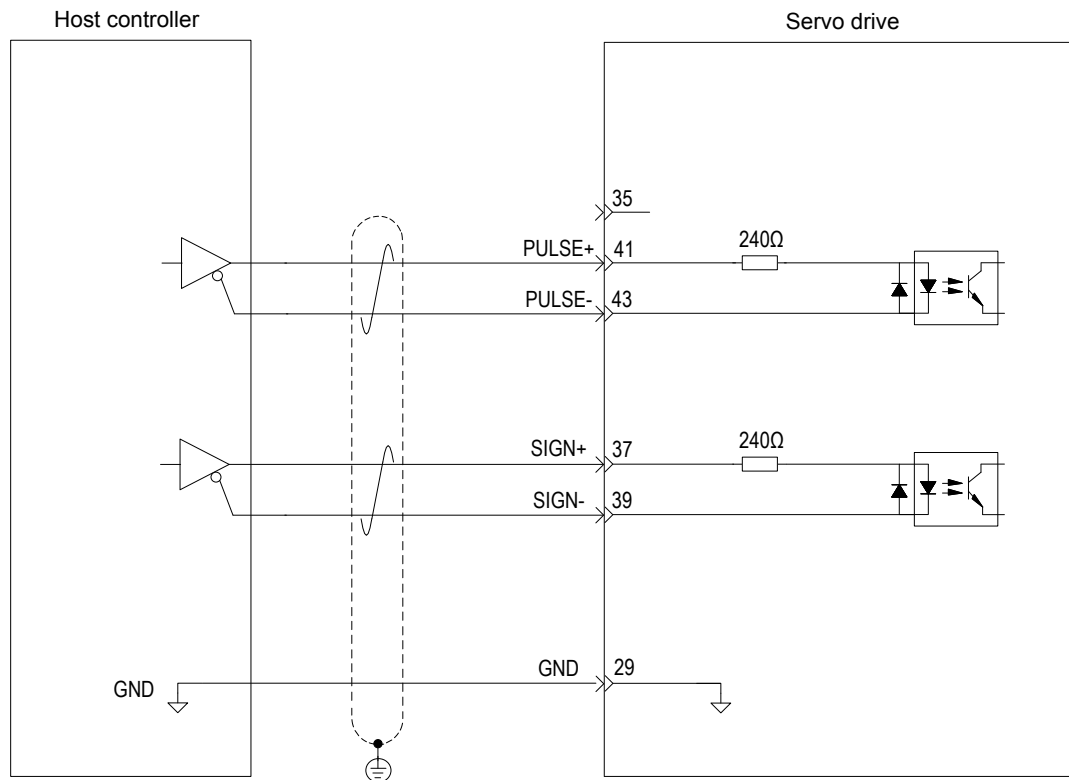

3

b. OC mode

When the internal 24 V power supply of the servo drive is used:

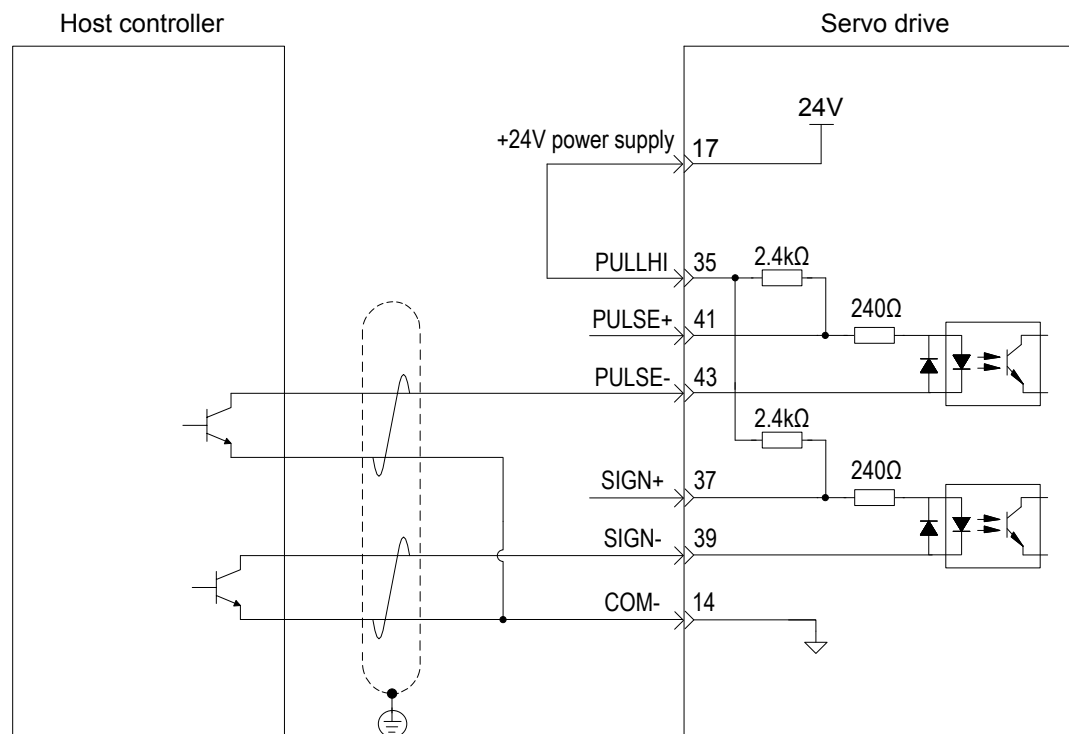

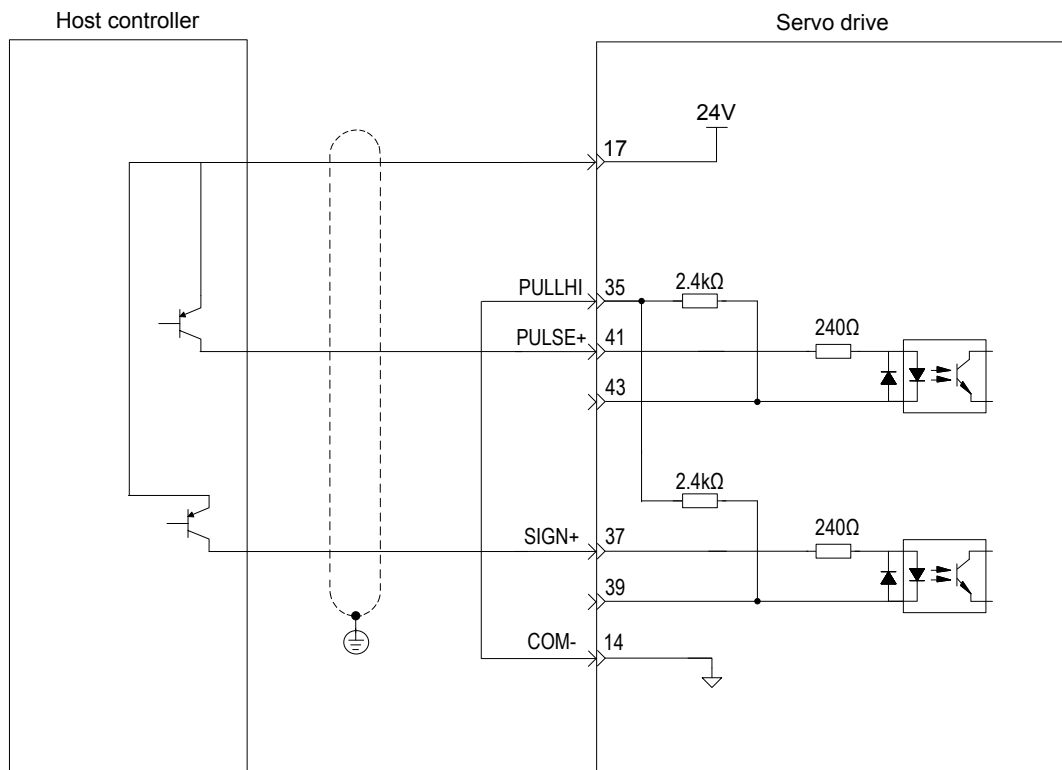

Wrong connection: Pin 14 (COM-) is not connected, which cannot form a closed-loop circuit.

3

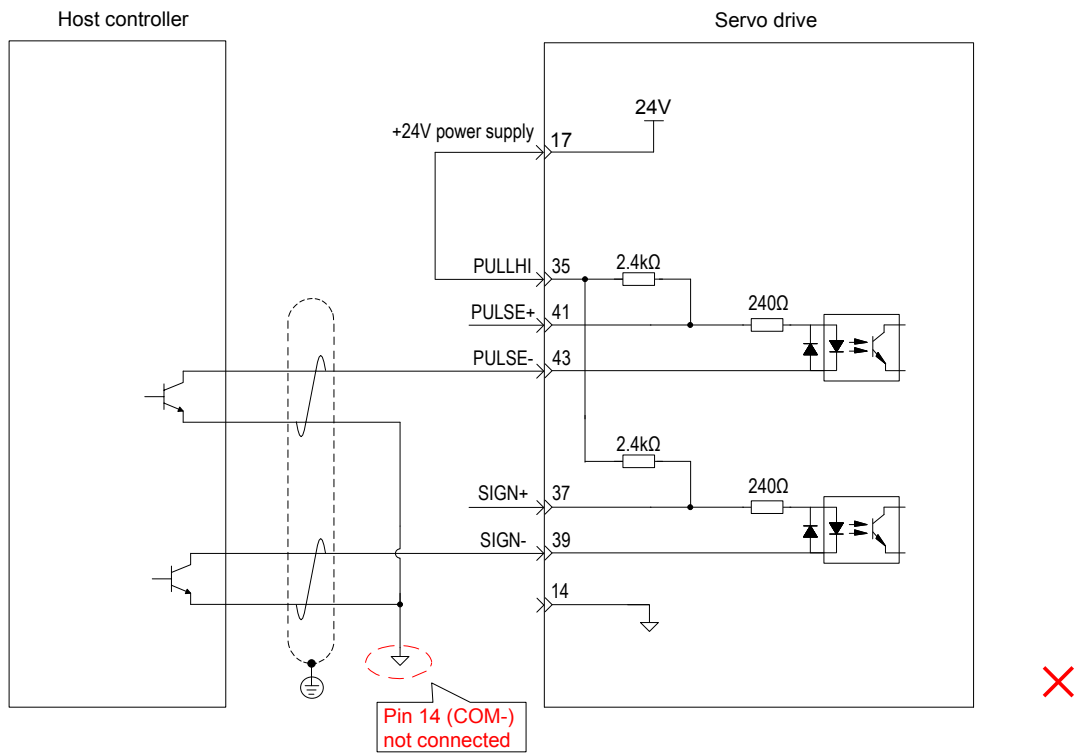

When the external power supply is used:

Scheme 1: Using the internal resistor of the servo drive (recommended)

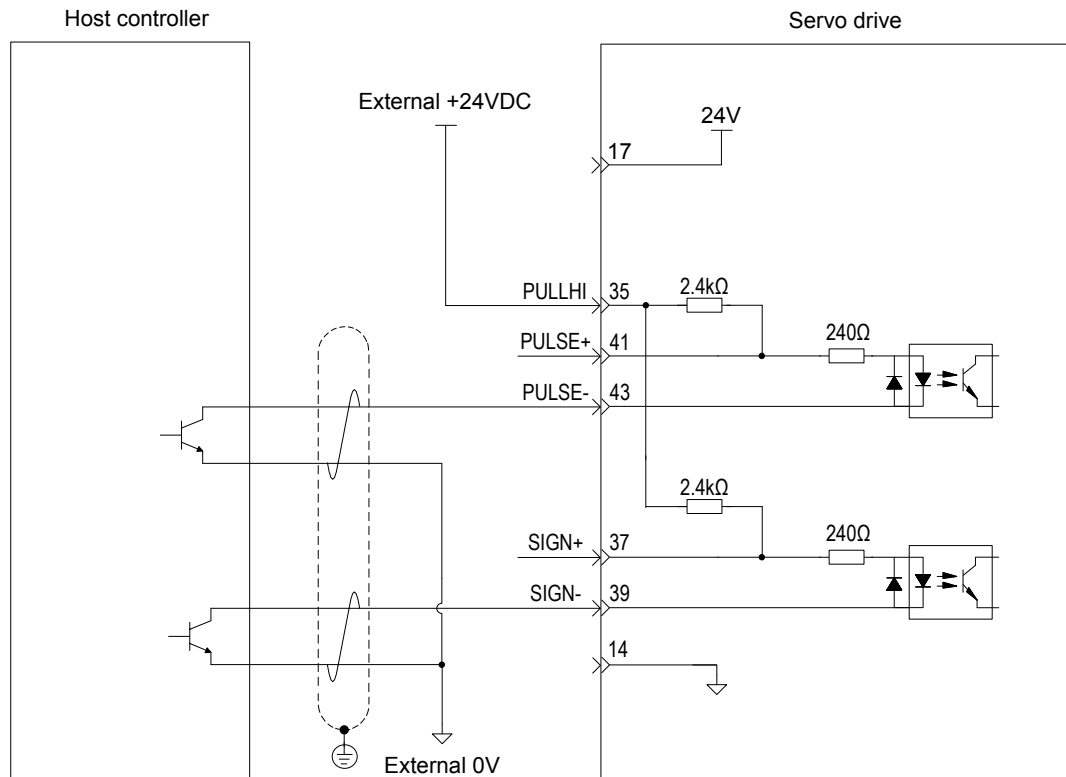

3

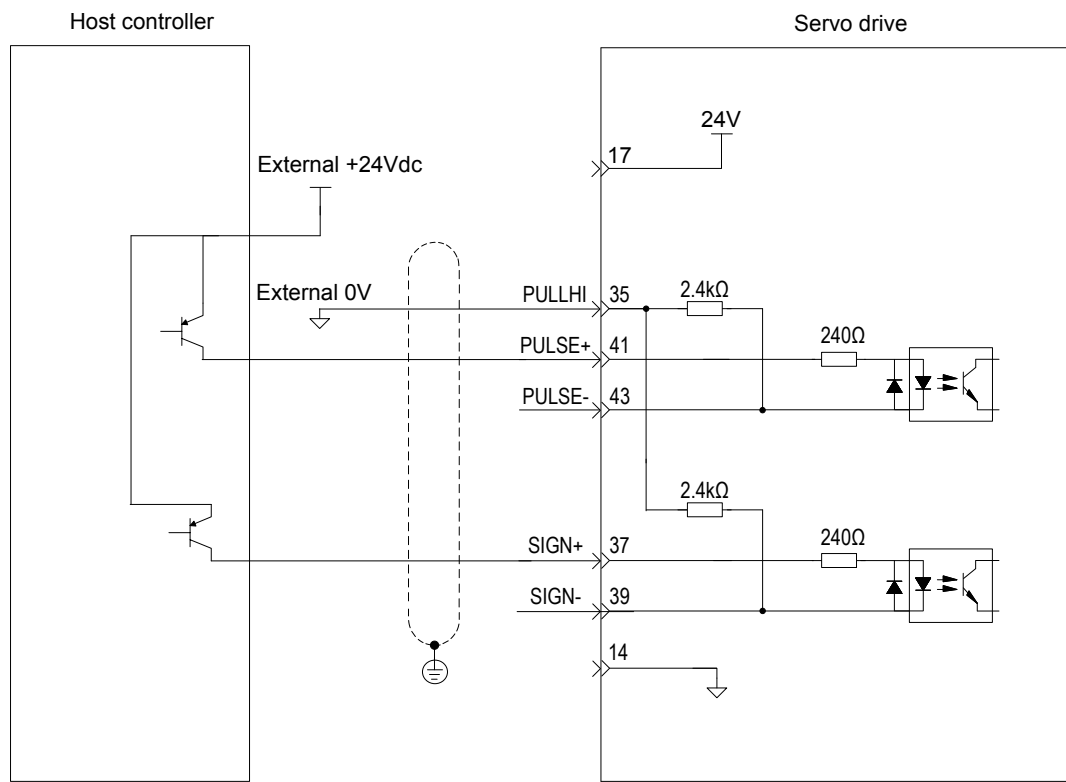

Scheme 2: Using the external resistor

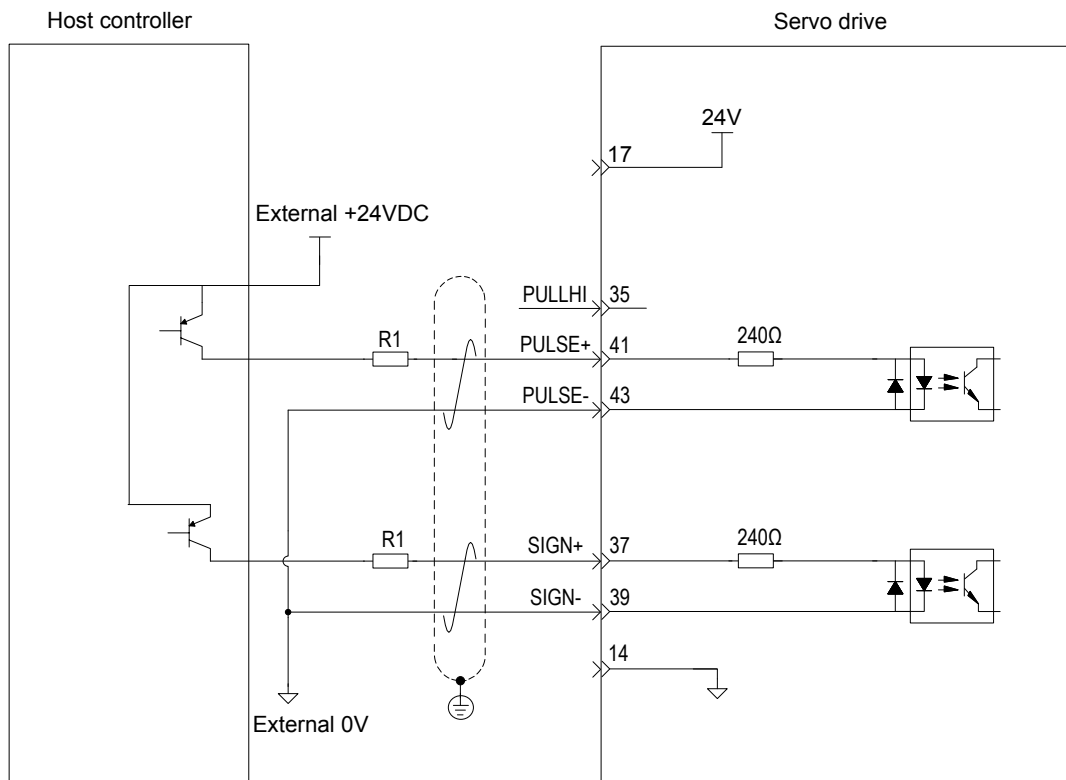
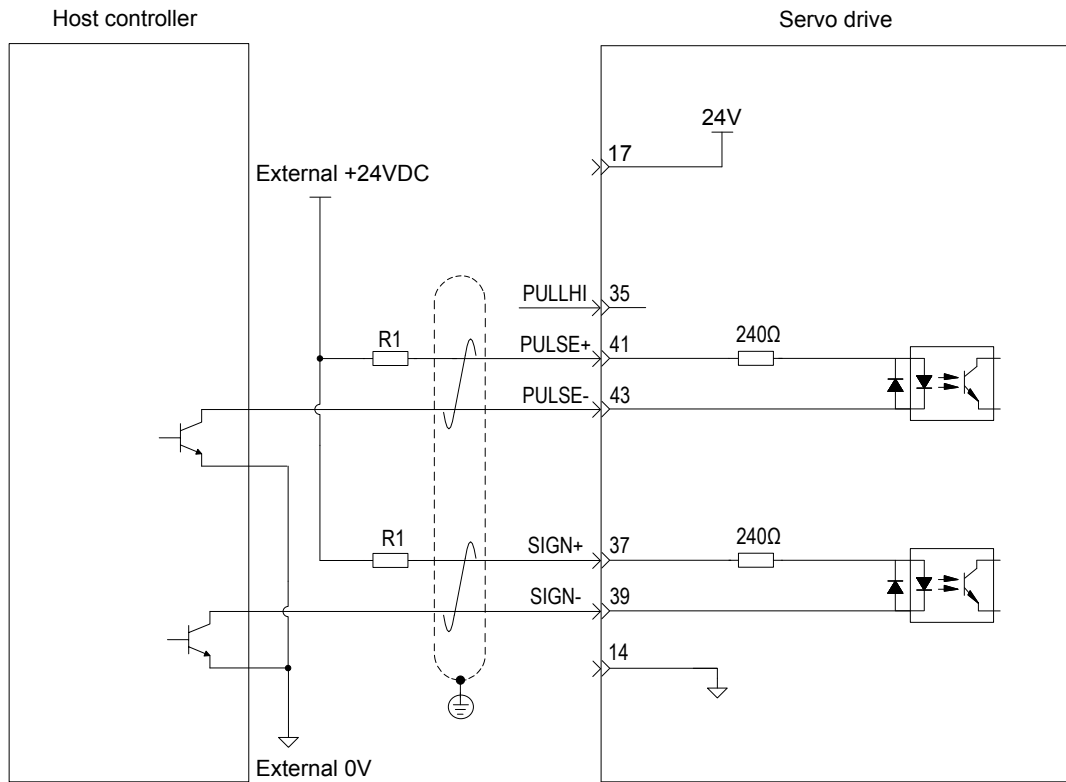

Value of resistor R1 is calculated according to the following formula:

$$\frac{V_{CC}-1.5}{R1+240} = 10\text{mA}$$

Table 3-23 Recommended R1 resistance

V _{CC} Voltage	R1	Power of R1
24 V	2.4 kΩ	0.5 W
12 V	1.5 kΩ	0.5 W

The following figures show the wrong wiring examples.

Wrong connection 1: The current-limit resistor is not connected, resulting in burnout of terminals.

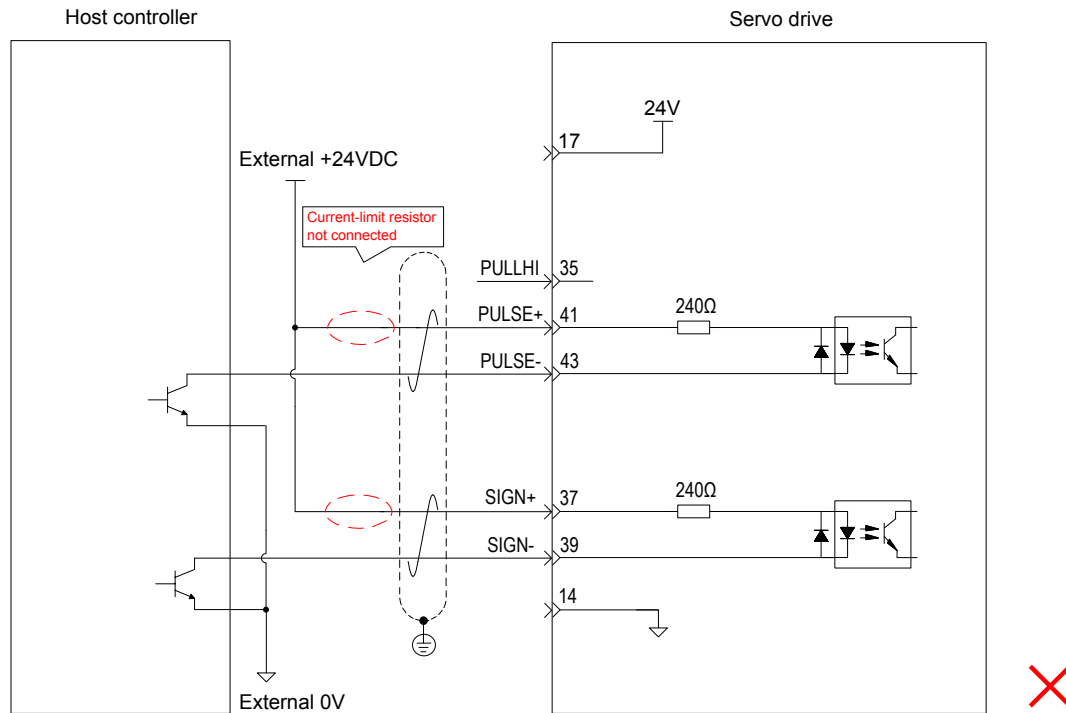

Wrong connection 2: Multiple terminals share the same current-limit resistor, resulting in pulse receiving error.

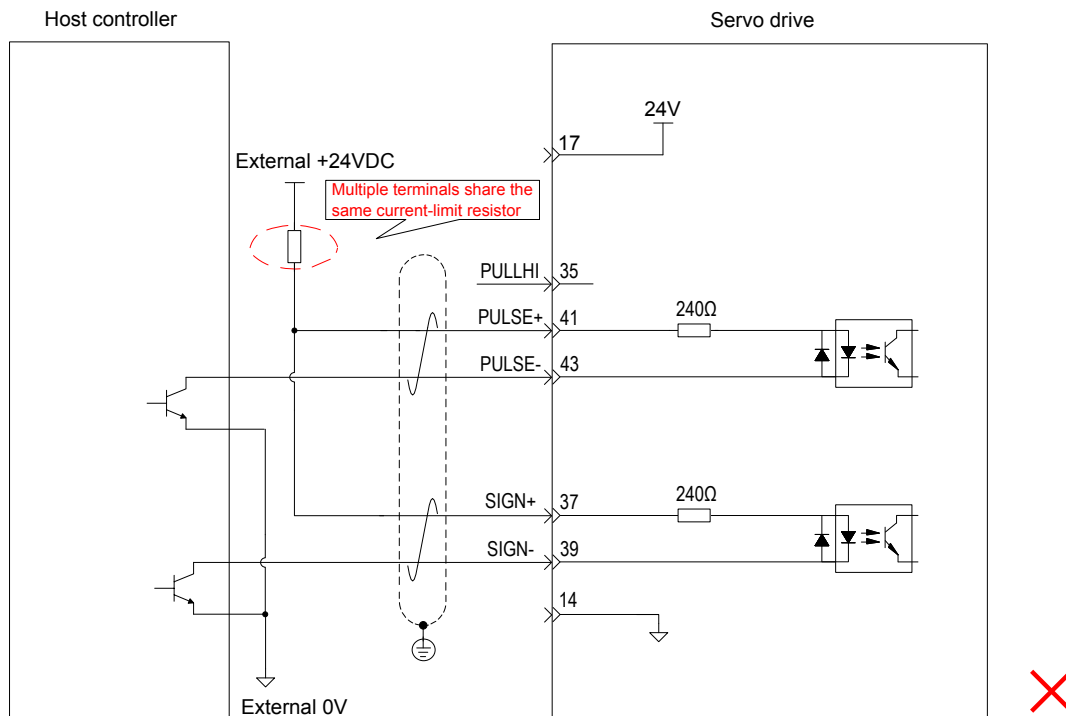

3

Wrong connection 3: SIGN terminals are not connected, resulting in that these two terminals receive no pulses.

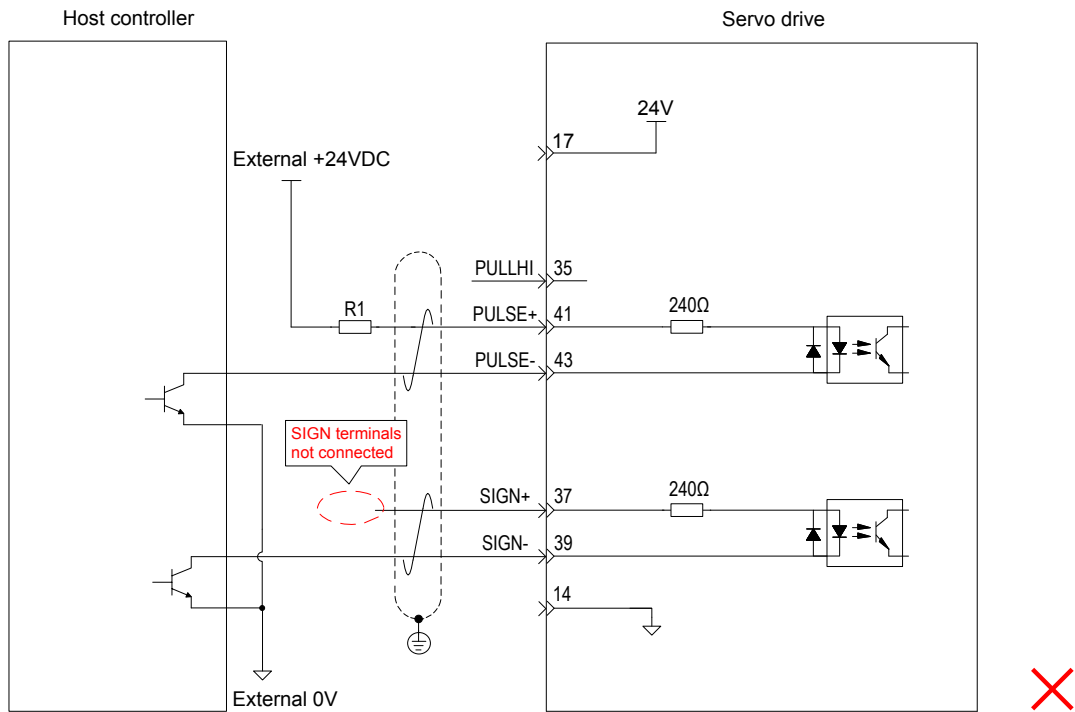

Wrong connection 4: Terminals are not correctly connected, resulting in burnout of terminals.

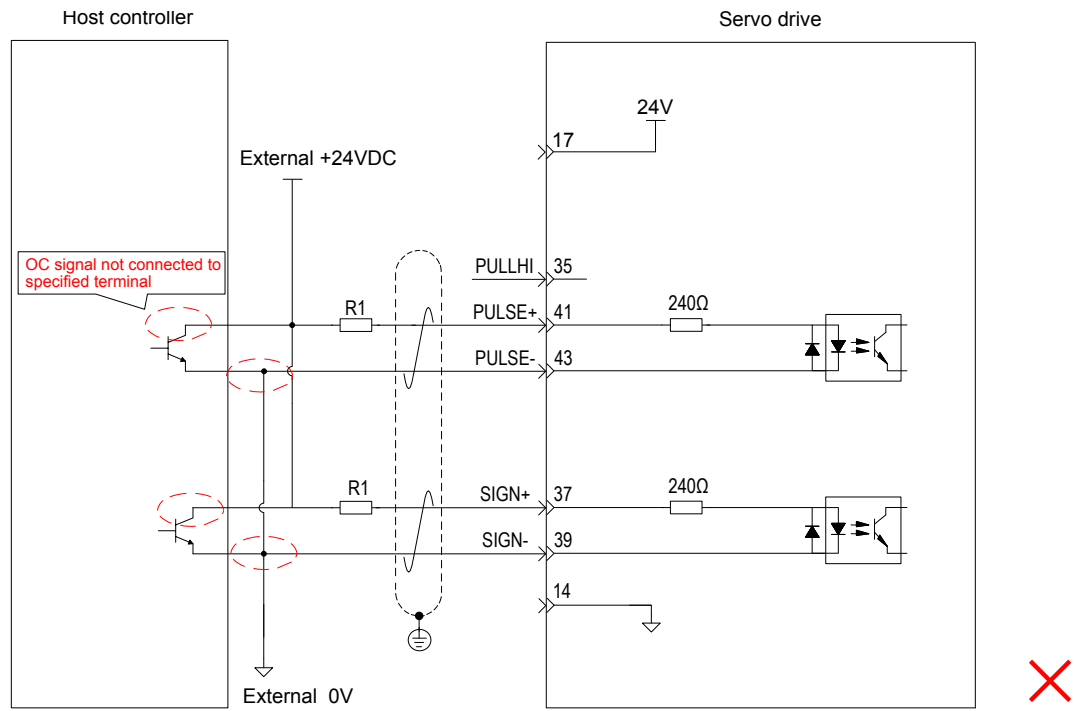

3

Wrong connection 5: Multiple terminals share the same current-limit resistor, resulting in pulse receiving error.

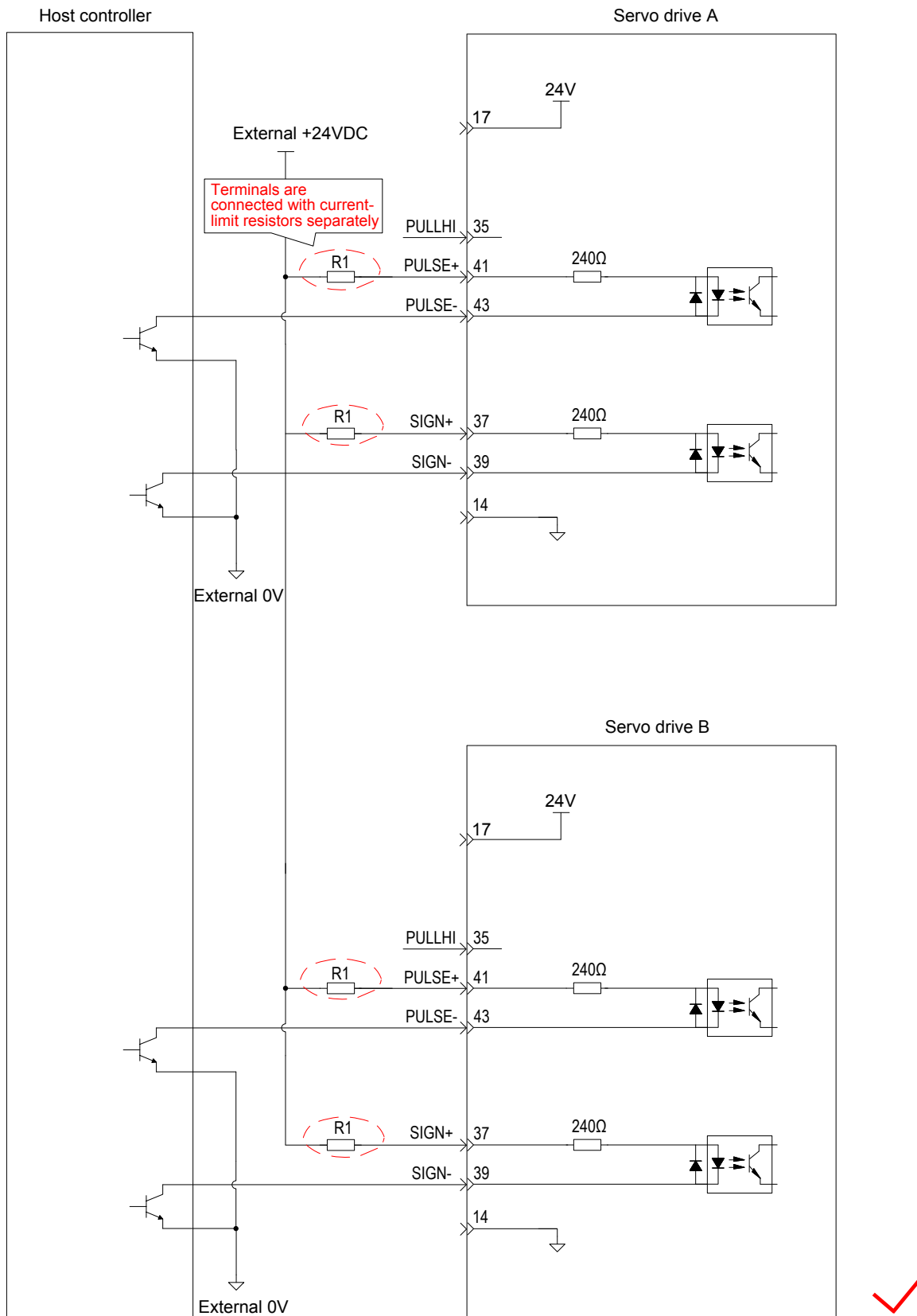

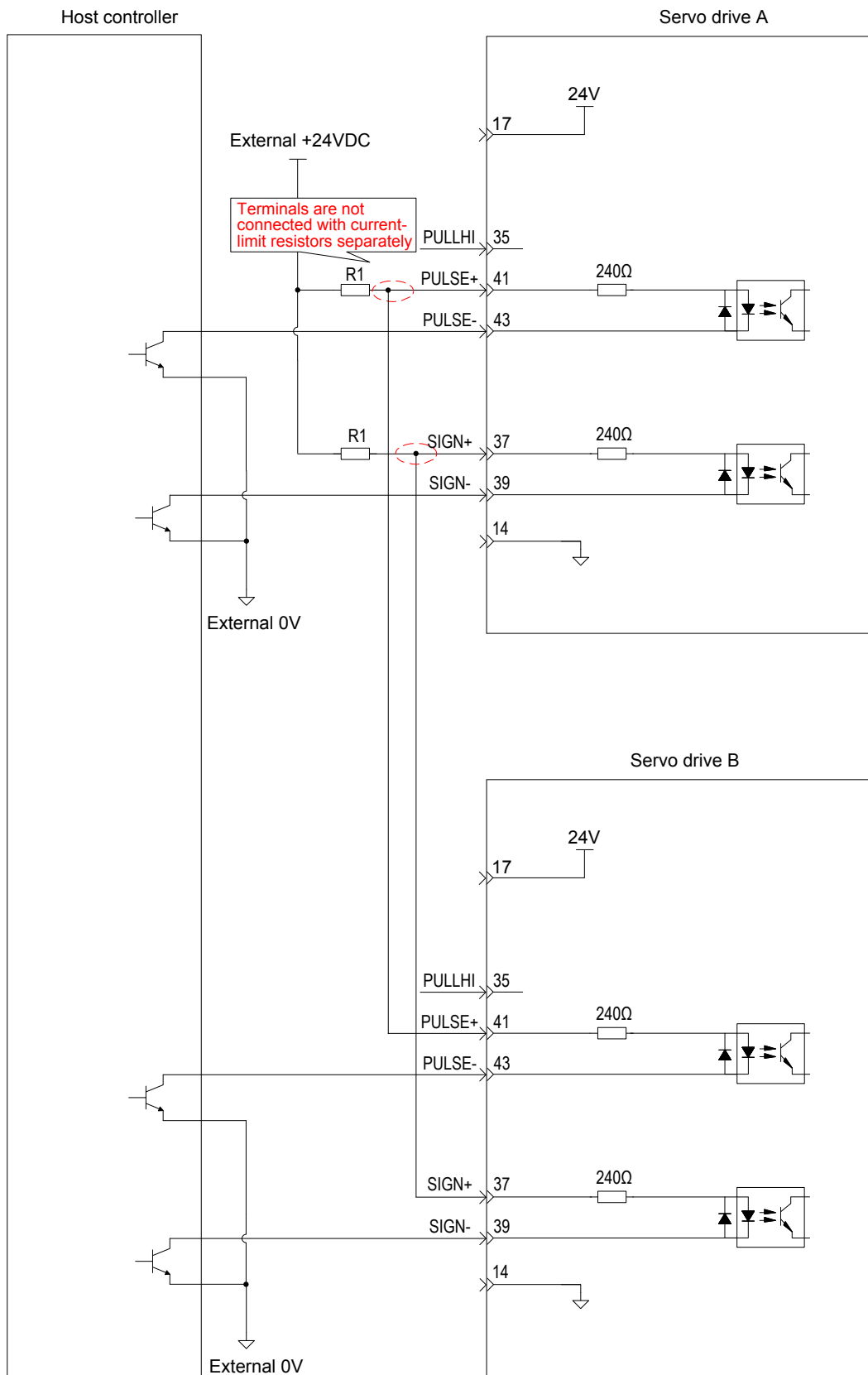

3

2) High-speed pulse input

High-speed reference pulse and symbol signals on the host controller side can only be output to the servo drive via differential drive output.

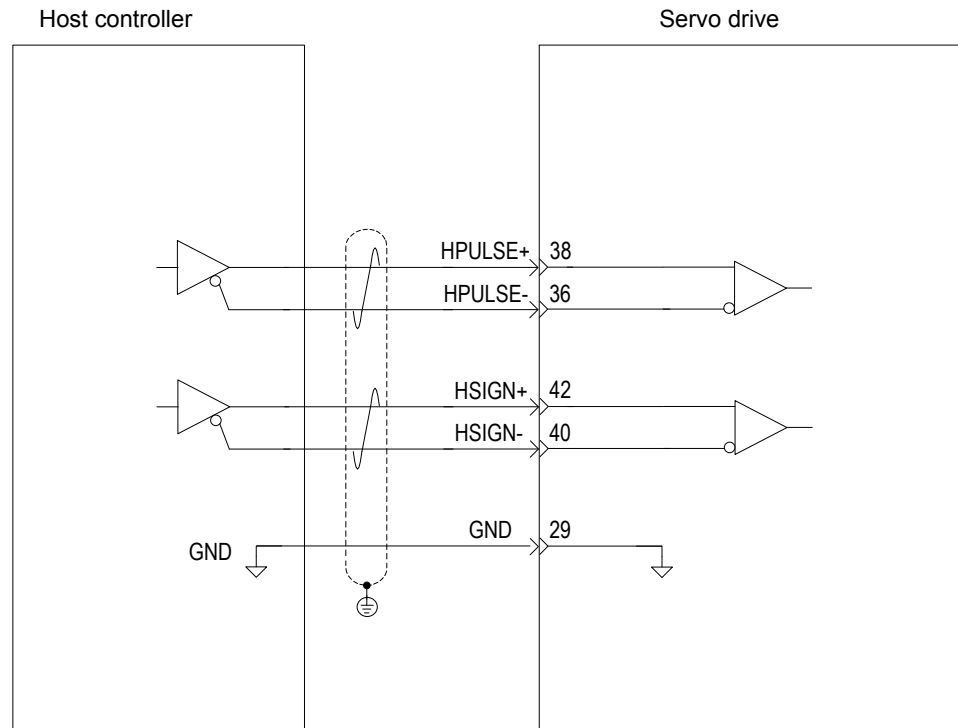

3

**CAUTION**

Make sure the differential input is 5V. Otherwise, input pulses of the servo drive are unstable, which will cause:
 When inputting reference pulses, pulse loss occurs.
 When inputting reference direction, the direction will reverse.
 The 5 V ground of the host controller must be connected to the GND terminal of the servo drive to reduce noise interference.

3.4.2 AI Signals

Table 3-24 AI signal description

Signal	Default Function	Pin No.	Function Description
Analog	AI2	18	Ordinary analog input signals Resolution: 12 bit Input voltage: maximum $\pm 12V$
	AI1	20	
	GND	19	Analog input signal ground

Speed and torque analog signal input terminals are AI1 and AI2, resolution of which is 12-bit. Corresponding voltage values are set via group H03 parameters.

Input voltage range: -10 to +10 V; resolution: 12 bit;

Maximum permissible voltage: $\pm 12 V$;

Input impedance: $\approx 9 k\Omega$

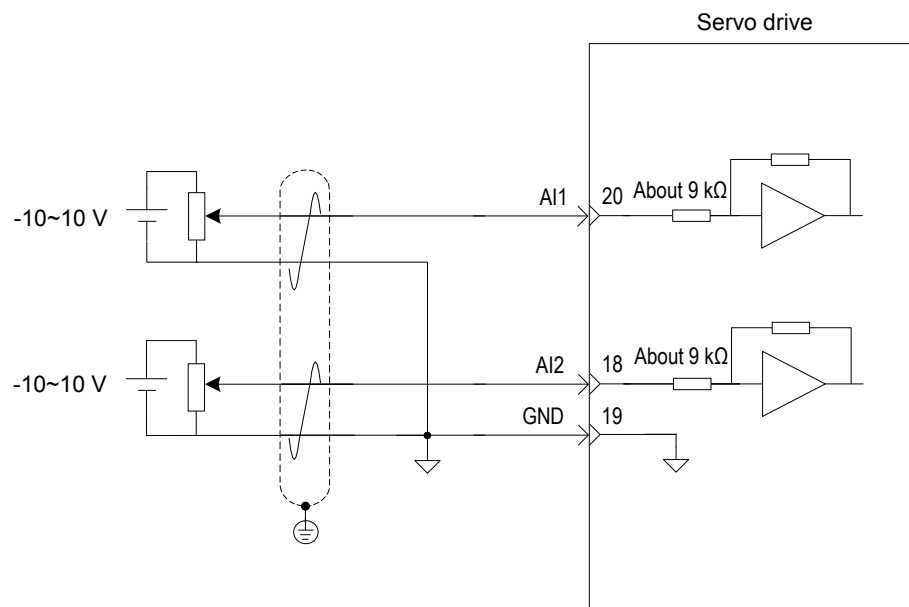

3.4.3 DI/DO Signals

Table 3-25 DI/DO signal description

Signal	Default Function	Pin No.	Function Description	
DI1	P-OT	9	Forward limit switch	
DI2	N-OT	10	Reverse limit switch	
DI3	INHIBIT	34	Pulse input inhibited	
DI4	ALM-RST	8	Alarm reset (edge valid)	
DI5	S-ON	33	Servo ON	
DI6	ZCLAMP	32	Zero speed clamp	
DI7	GAIN-SEL	31	Gain switchover	
DI8	HomeSwitch	30	Home switch	
DI9	Reserved	12	-	
General	+24V	17	Internal 24 V power supply, voltage range: 20 to 28 V, maximum output current: 200 mA	
	COM-	14		
	COM+	11	Power input (12 to 24 V)	
	DO1+	S-RDY+	7	Servo ready
	DO1-	S-RDY-	6	
	DO2+	COIN+	5	Position reached
	DO2-	COIN-	4	
	DO3+	ZERO+	3	Zero speed
	DO3-	ZERO-	2	
	DO4+	ALM+	1	Fault output
DO4-	ALM-	26		
DO5+	HomeAttain+	28	Homing completed	
DO5-	HomeAttain-	27		

1) DI circuit

DI1 to DI9 circuits are the same. The following takes DI1 circuit as an example.

a. The host controller provides relay output.

When the internal 24 V power supply of the servo drive is used:

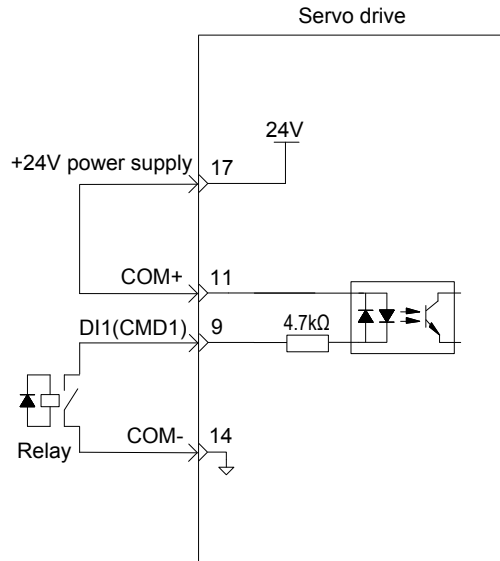

3

When the external power supply is used:

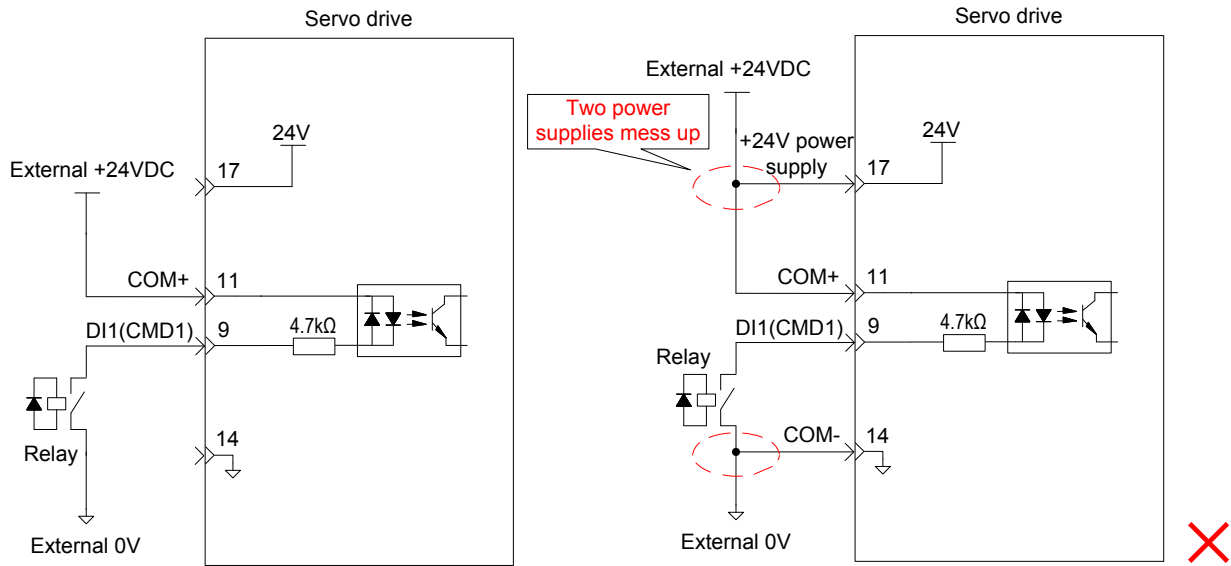

b. The host controller provides OC output.

When the internal 24 V power supply of the servo drive is used:

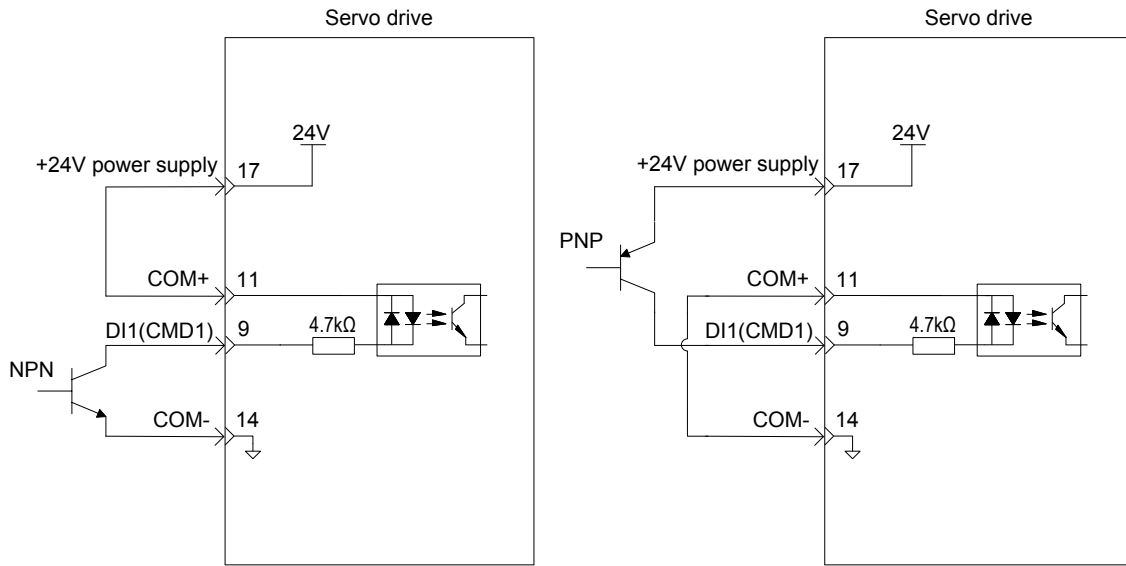

When the external power supply is used:

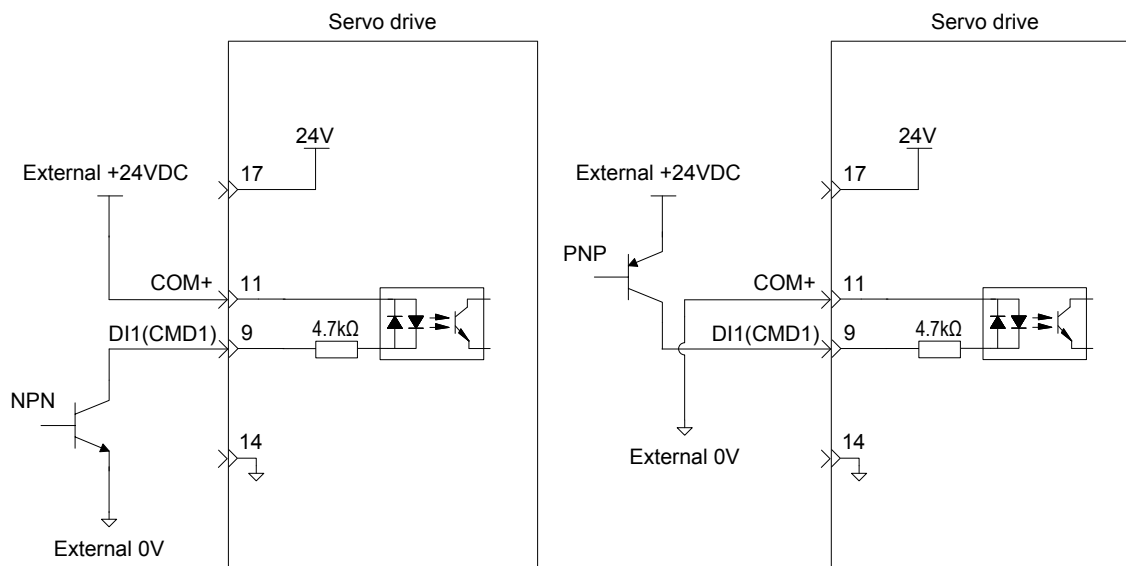

Note	PNP and NPN input must not be applied in the same circuit.
-------------	--

2) DO circuit

DO1 to DO5 circuits are the same. The following takes DO1 circuit as an example.

a. The host controller uses relay input.

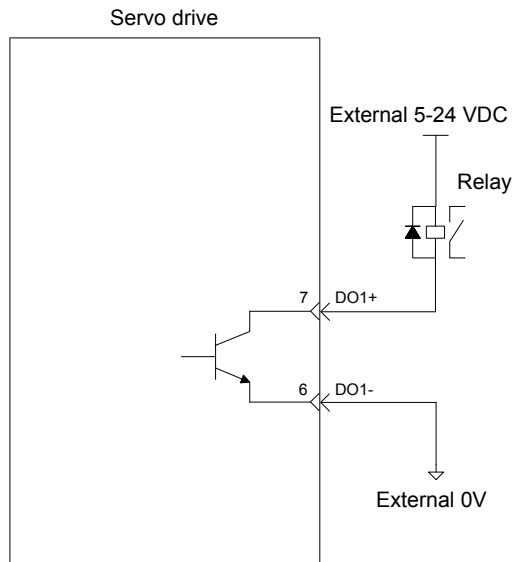

Note When the host controller provides relay input, a flywheel diode must be installed; otherwise, the DO terminals may be damaged.

3

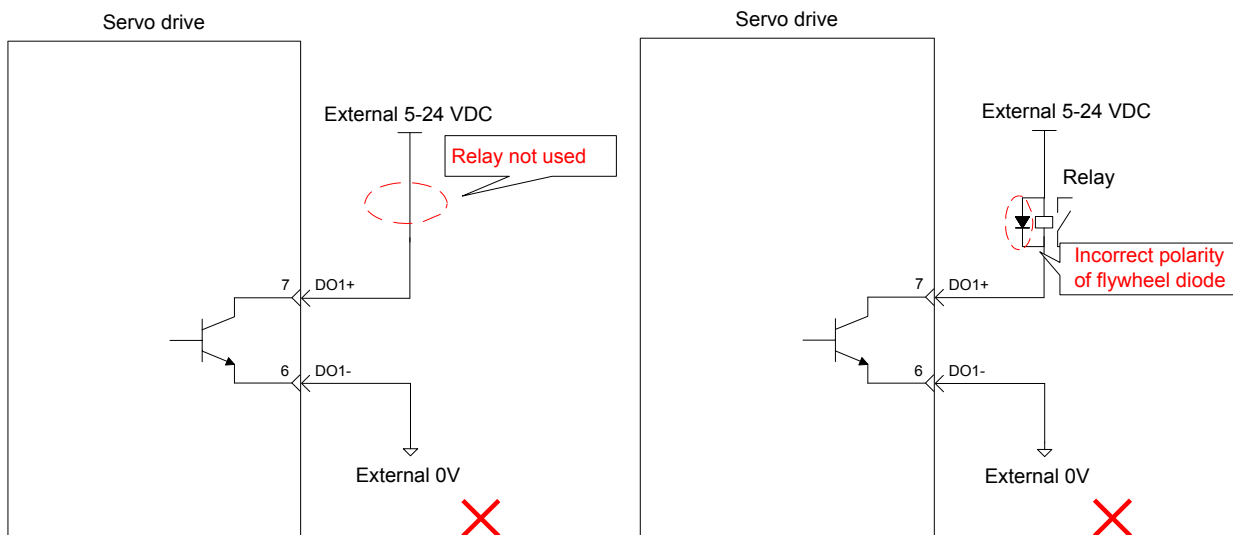

b. The host controller uses optocoupler input.

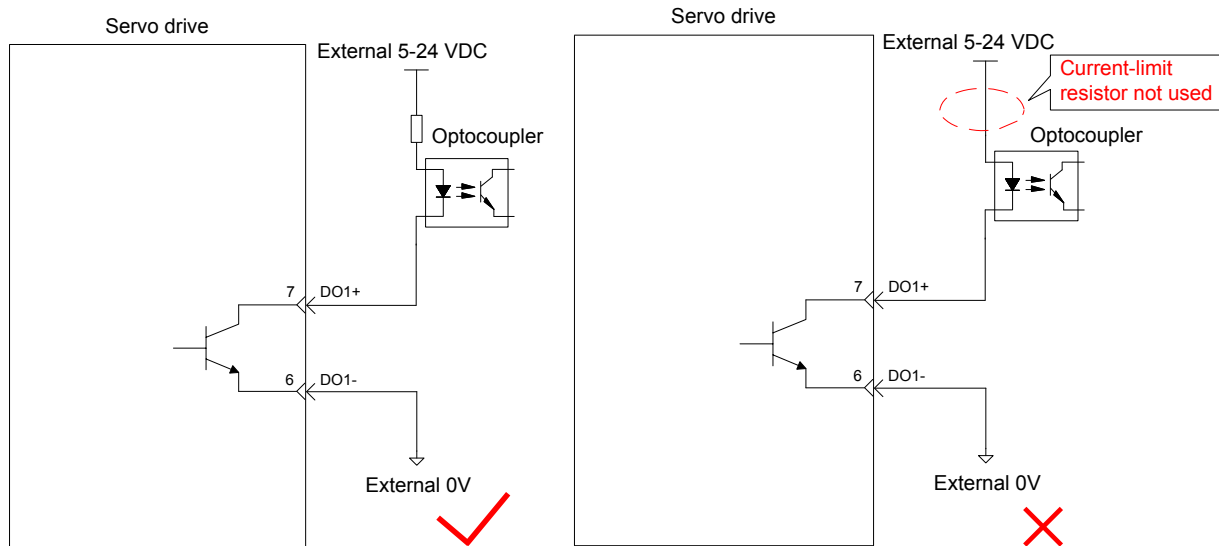

The maximum permissible voltage and current of the optocoupler output circuit inside the servo drive are as follows:

Maximum voltage: 30 VDC

Maximum current: DC 50 mA

3.4.4 Encoder Frequency-Division Output Circuit

Table 3-26 Encoder frequency-division output signal specifications

Signal	Default Function	Pin No.	Function Description	
General	PAO+	21	Phase A output signal	Phases A+B quadrature pulse output signal
	PAO-	22		
	PBO+	25	Phase B output signal	
	PBO-	23		
	PZO+	13	Phase Z output signal	Home pulse output signal
	PZO-	24		
	PZ-OUT	44	Phase Z output signal	Home pulse OC output signal
	GND	29	Home pulse OC output signal ground	
	+5V	15	5 V internal power supply	
GND	16	Maximum output current: 200 mA		
PE	Housing			

The encoder frequency-division output circuit outputs OC signals via the differential drive. Generally, it provides feedback signals to the host controller in the closed-loop position control system. A differential or optocoupler circuit shall be used in the host controller to receive feedback signals. The maximum output current is 20 mA.

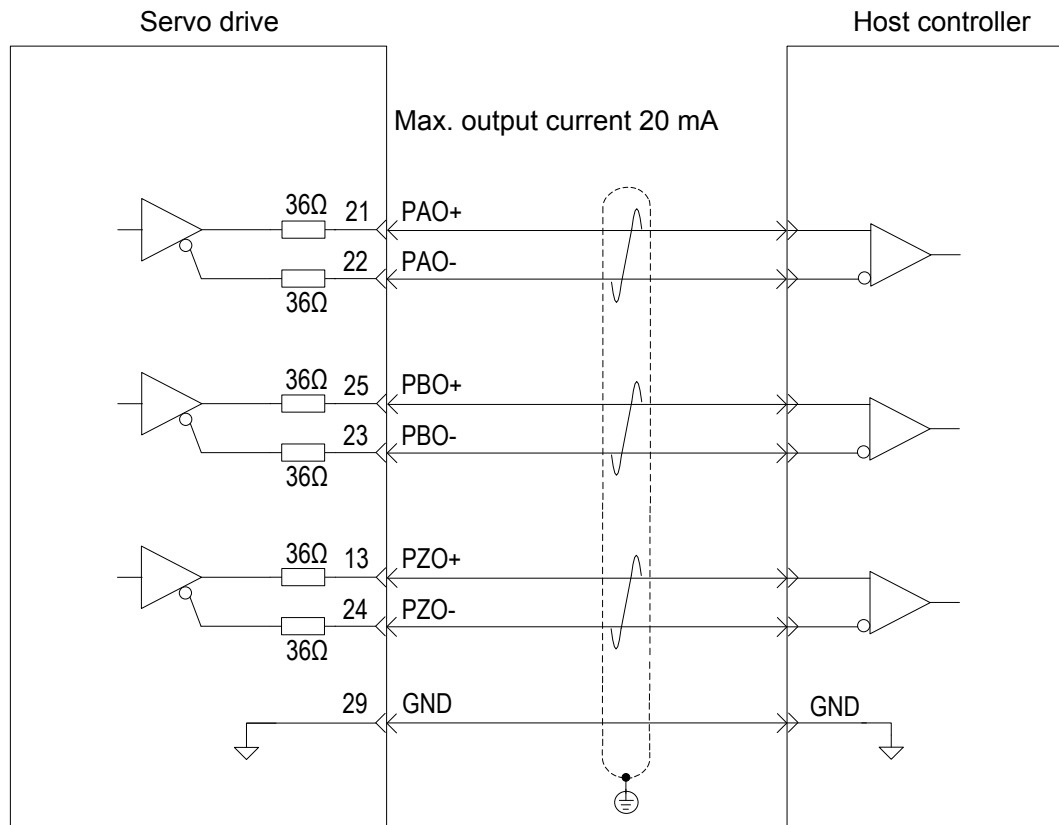

3

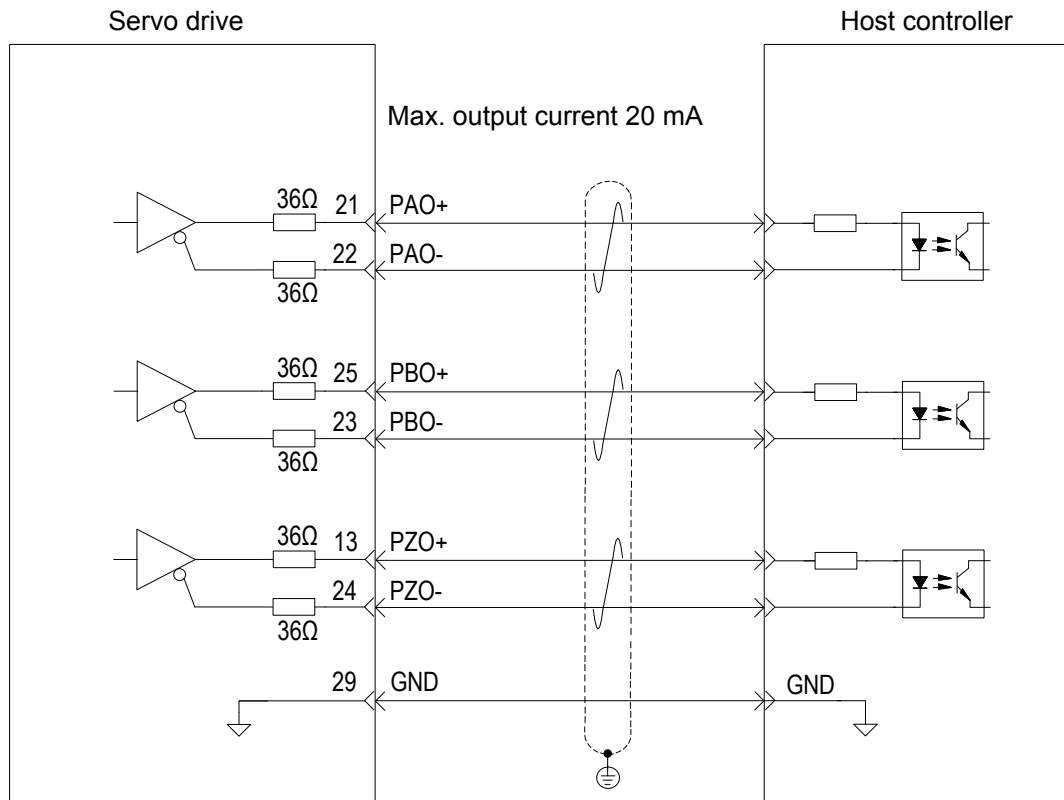

The encoder phase Z output circuit outputs OC signals. Generally, it provides feedback signals to the host controller in the closed-loop position control system. An optocoupler circuit, relay circuit, or bus receiver circuit shall be used in the host controller to receive feedback signals.

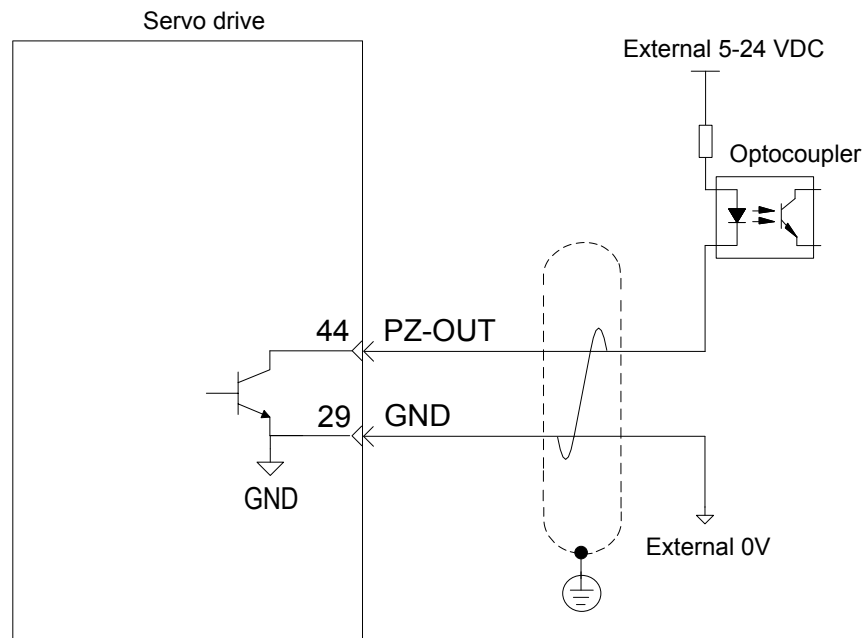

To reduce noise interference, connect the 5V ground of the host controller to the GND terminal of the servo drive, and use the shielded twisted-pair.

The maximum permissible voltage and current of the optocoupler output circuit inside the servo drive are as follows:

Maximum voltage: 30 VDC

Maximum current: DC 50 mA

3

3.4.5 Wiring of the Motor Brake

In the applications where the motor drives the vertical axis, this brake would be used to lock the motor in position, and hold and prevent the work (moving load) from falling by gravity or moving by external force while the power to the servo is shut off.

Figure 3-16 Application diagram of the motor brake

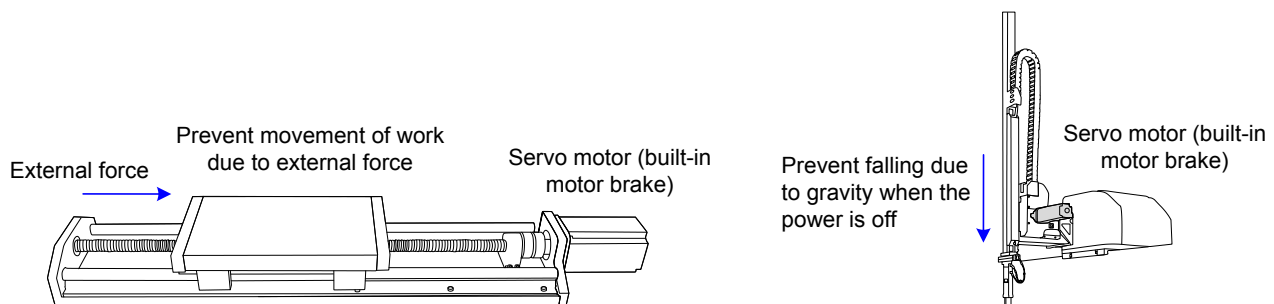

Use this built-in brake for "Holding" purpose only, that is to hold the stalling status. Never use this for "Brake" purpose to stop the load in motion.

The brake coil has no polarity.

After the servo motor stops, the S-ON signal must be off.

When the servo motor with brake runs, the brake may generate lining sound, which does not affect any functionality.

When brake coils are energized (the brake is released), magnetic flux leakage may occur at the shaft end. Thus, pay special attention when using magnetic sensors around the servo motor.

The connector of the motor brake has no polarity. Customers needs to prepare a 24 V external power supply. The following figure shows the standard wiring of the brake signal (BK) and motor brake power supply.

Figure 3-17 Wiring diagram of the motor brake

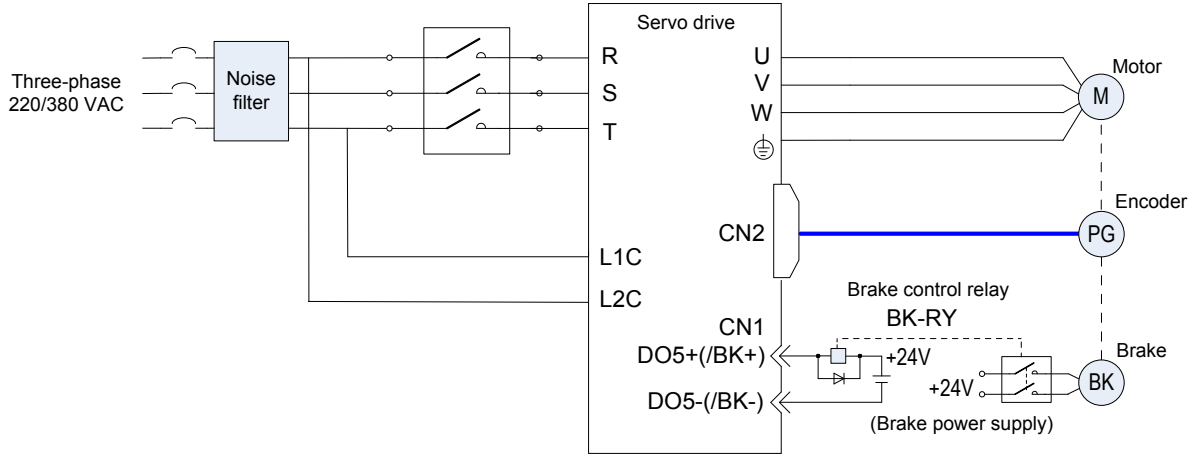

Pay attention to the following precautions at wiring:

When deciding the length of the cable on the motor brake side, consider voltage drop caused by the cable resistance. The input voltage must be at least 21.6 V to make the brake work. The following table lists brake specifications of ISMH servo motors.

3

Table 3-27 Brake specifications

Servo Motor Model	Holding Torque (N·m)	Supplied Voltage (V)±10%	Resistance (Ω) ±7%	Supplied Current Range (A)	Release Time (ms)	Applying Time (ms)
ISMH1-10B	0.32	24	96	0.23–0.27	20	35
ISMH1-20B/40B	1.3	24	89.5	0.25–0.34	20	50
ISMH1-75B	2.4	24	50.1	0.40–0.57	20	60
ISMH2-10C/15C/20C/25C	8	24	24	0.81–1.14	30	85
ISMH2-30C/40C/50C	16	24	21.3	0.95–1.33	60	100
ISMH3-85B/13C/18C	16	24	21.3	0.95–1.33	60	100
ISMH3-29C/44C/55C/75C	50	24	14.4	1.47–2.07	100	200
ISMH4-40B	1.3	24	89.5	0.25–0.34	20	50
ISMH4-75B	2.4	24	50.1	0.40–0.57	20	60

The brake shall not share the power supply with other devices. Otherwise, the brake may malfunction due to voltage or current drop resulted from working of other devices.

Cables of 0.5 mm² and above are recommended.

3.5 Wiring to Communication Signal Terminal Connectors CN3/CN4

Figure 3-18 Wiring diagram of communication signal terminals

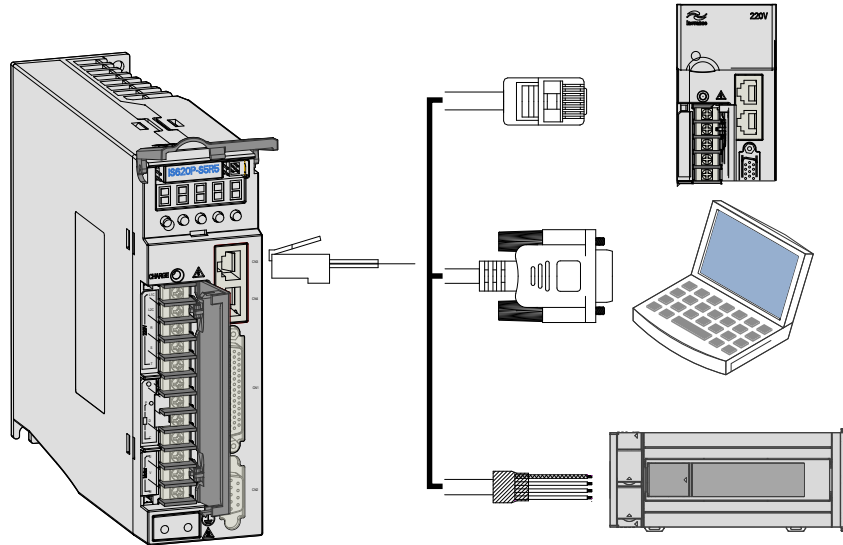

CN3 and CN4 are two same communication signal terminal connectors connected in parallel. Do not connect cables to the reserved pins.

3

3.5.1 Communication Signal Terminal Connectors

The CAN3/CN4 terminals of the servo drive are used for communication connection between the servo drive and the PC, PLC, and other servo drives. The following figure shows the pin definitions of the CAN3/CN4 terminals.

Table 3-28 Pin definition of communication signal terminal connectors

Pin No.	Pin	Description	Pin Layout
1	CANH	CAN communication port	
2	CANL		
3	CGND	CAN communication ground	
4	RS485+	RS485 communication port	
5	RS485-		
6	RS232-TXD	RS232 transmitting end, connected to the receiving end of the host controller	
7	RS232-RXD	RS232 transmitting end, connected to the sending end of the host controller	
8	GND	Ground	
Housing	PE	Shield	

3.5.2 CAN Communication Connection

1) CAN communication connection with PLC

The following figure shows the cable connection between the servo drive and the PLC under CAN communication.

Figure 3-19 Appearance of communication cable between servo drive and PLC

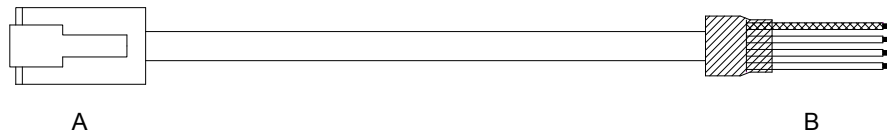

Table 3-29 Pin definition of communication cable between servo drive and PLC

RJ45 on Servo Drive Side (A)			PC Side (B)		
Type	Signal	Pin No.	Type	Signal	Pin No.
CAN	CANH	1	CAN	CANH	1
	CANL	2		CANL	2
	CGND	3		CGND	3
	PE (shield)	Housing		PE (shield)	Housing

3

2) CAN communication connection for multi-drive use

The following figure shows the cable connection between multiple servo drives under CAN communication.

Figure 3-20 Appearance of communication cable for parallel connection of multiple servo drives

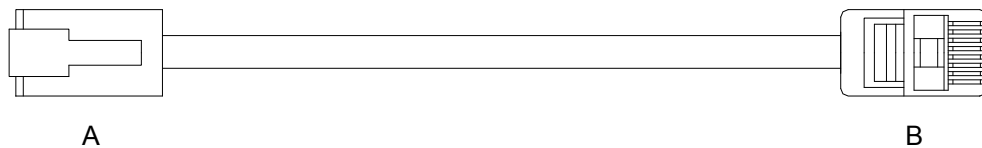

Table 3-30 Pin connection relation of communication cable for parallel connection

RJ45 on Servo Drive Side (A)			RJ45 on Servo Drive Side (B)		
Type	Signal	Pin No.	Type	Signal	Pin No.
CAN	CANH	1	CAN	CANH	1
	CANL	2		CANL	2
	CGND	3		CGND	3
	PE (shield)	Housing		PE (shield)	Housing

3) Grounding precautions of CAN communication

When using CAN communication, connect the CGND terminal of the host controller to that of the servo drive, as shown in the following figure.

Figure 3-21 Correct CAN communication connection

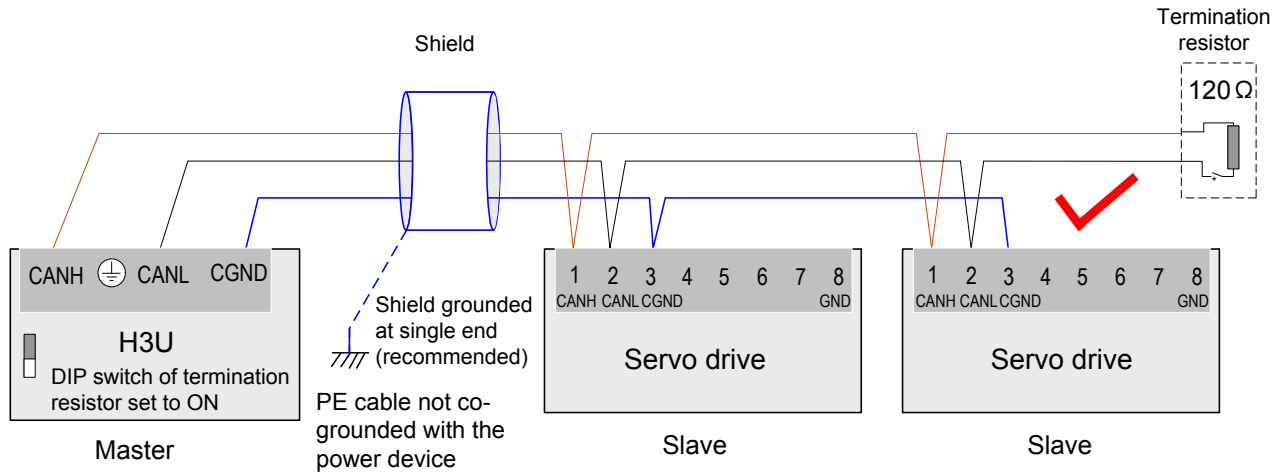

The DIP switch in the built-in termination resistor of the PLC for CAN communication must be set to ON.

It is recommended that the shield be grounded at single end.

Do not connect the GND terminal (⊕) of the host controller to the CGND terminal of the servo drive. Failure to comply will damage the devices.

Figure 3-22 Wrong CAN communication connection

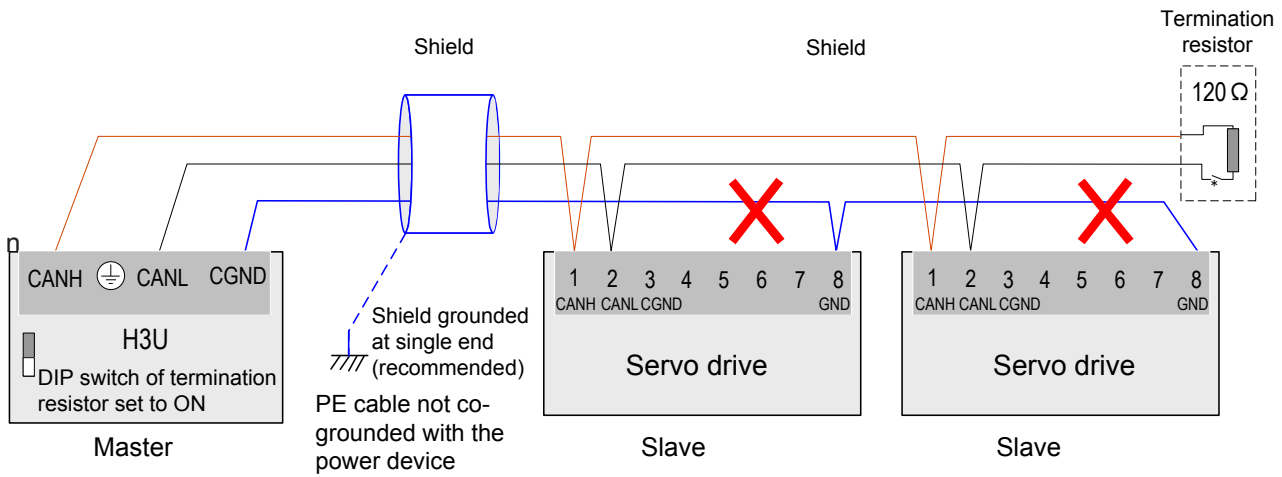

3.5.3 RS485 Communication Connection

1) RS485 communication connection with PLC

The following figure shows the cable connection between the servo drive and the PLC under RS485 communication.

Figure 3-23 Appearance of communication cable between servo drive and PLC

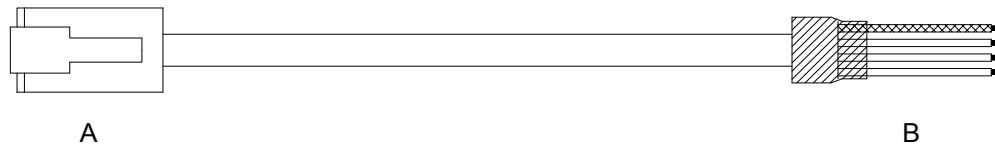

Table 3-31 Pin definition of communication cable between servo drive and PLC

RJ45 on Servo Drive Side (A)			PLC Side (B)		
Type	Signal	Pin No.	Type	Signal	Pin No.
RS485	RS485+	4	RS485	RS485+	4
	RS485-	5		RS485-	5
	GND	8		GND	8
	PE (shield)	Housing		PE (shield)	Housing

2) RS485 communication connection for multi-drive use

The following figure shows the cable connection between multiple servo drives under RS485 communication.

Figure 3-24 Appearance of communication cable for parallel connection of multiple servo drives

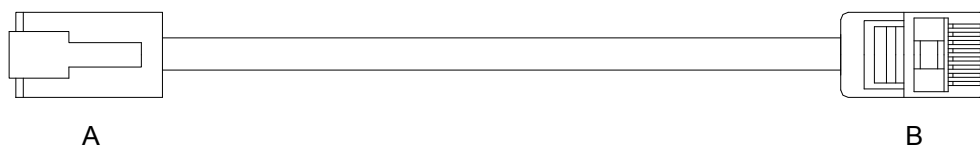

3

Table 3-32 Pin connection relation of communication cable for parallel connection

RJ45 on Servo Drive Side (A)			RJ45 on Servo Drive End (B)		
Type	Signal	Pin No.	Type	Signal	Pin No.
RS485	RS485+	4	RS485	RS485+	4
	RS485-	5		RS485-	5
	GND	8		GND	8
	PE (shield)	Housing		PE (shield)	Housing

3) Grounding precautions of RS485 communication

When using RS485 communication, connect the GND terminal (⊕) of the host controller to that of the servo drive, as shown in the following figure.

Figure 3-25 Correct RS485 connection

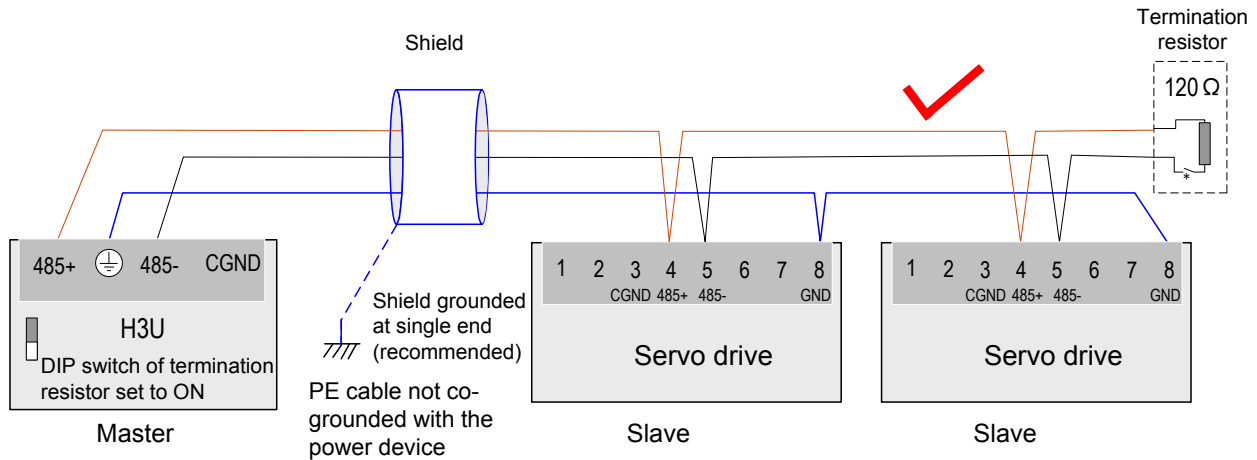

The DIP switch in the built-in termination resistor of the PLC for RS485 communication must be set to ON.
 It is recommended that the shield be grounded at single end.
 Do not connect the GND terminal (⊖) of the host controller to the CGND terminal of the servo drive. Failure to comply will damage the devices.

Figure 3-26 Wrong RS485 connection

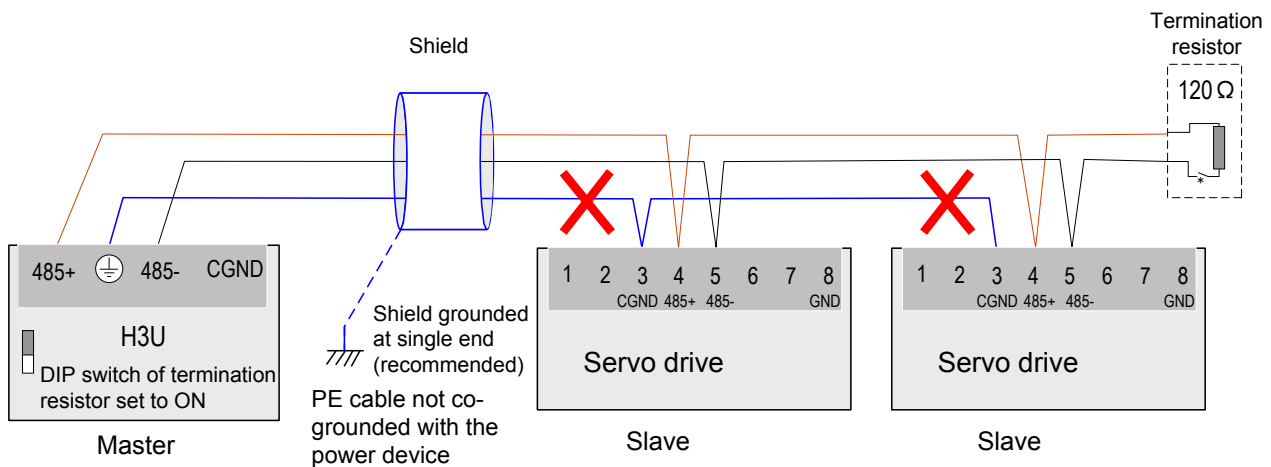

3

3.5.4 RS232 Communication Connection with PC

Connect the servo drive and the PC by using the PC communication cable. The common communication port RS232 is suggested. The following figure shows the cable diagram.

Figure 3-27 PC communication cable appearance

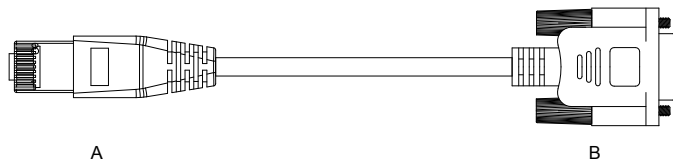
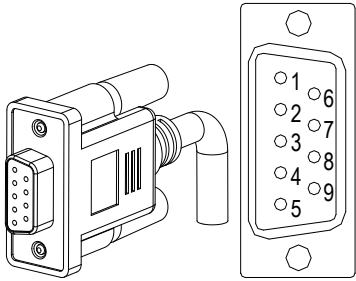

Table 3-33 Pin connection relation of the PC communication cable

RJ45 on Servo Drive Side (A)		DB9 on PC Side (B)	
Signal	Pin No.	Signal	Pin No.
RS232-TXD	6	PC-RXD	2
RS232-RXD	7	PC-TXD	3
GND	8	GND	5
PE (shield)	Housing	PE (shield)	Housing

The following table describes the pin definition of the DB9 terminal on PC side.

Table 3-34 Pin definition of DB9 terminal on PC side

Pin No.	Name	Description	Pin Layout
2	PC-RXD	PC receiving end	
3	PC-TXD	PC sending end	
5	GND	Ground	
Housing	PE	Shield	

3

If the host controller provides only the USB interface, use the serial-to-USB cable for conversion.

Figure 3-28 Serial-to-USB conversion diagram

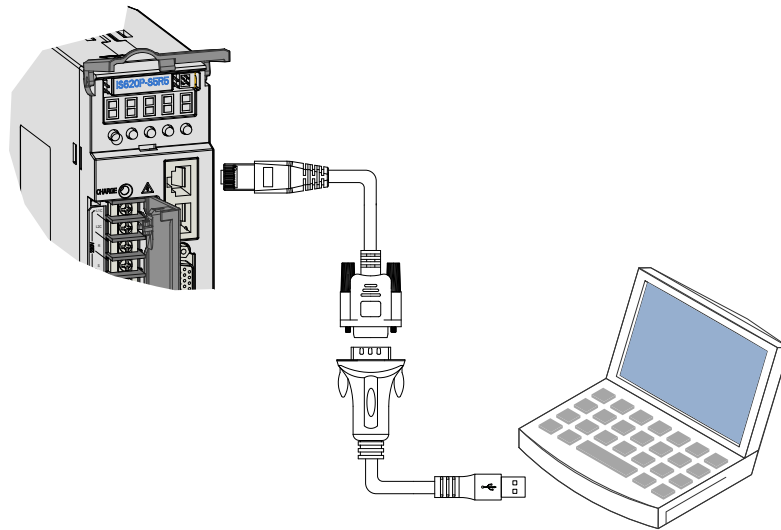

The recommended cable is as follows:

Z-TEK, model: ZE551A, 0.8-m USB extension cable, chip model: FT232

3.6 Wiring of Analog Monitoring Signal Terminal Connector CN5

The following figure shows pin layout of the analog monitoring signal terminal connector CN5.

Figure 3-29 Analog monitoring signal terminal connector

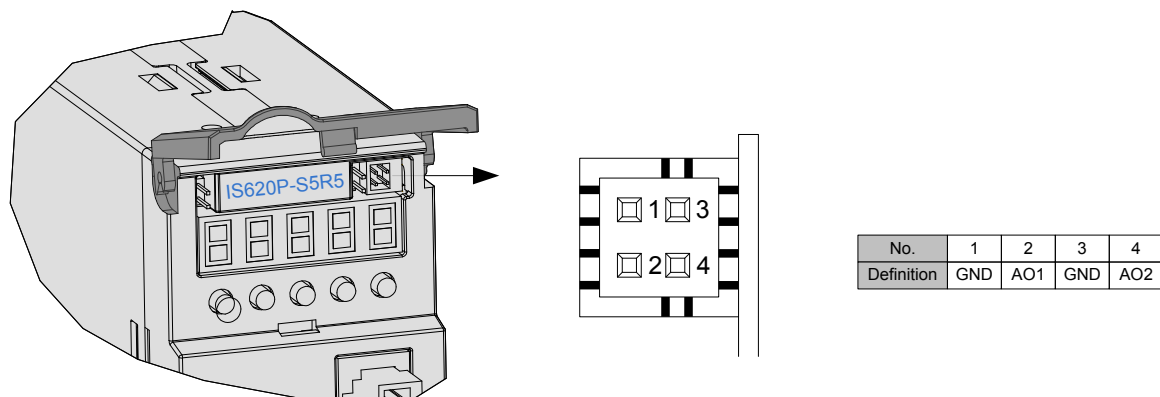

Corresponding interface circuit:

Analog output: -10 to +10 V

Maximum output current: 1 mA

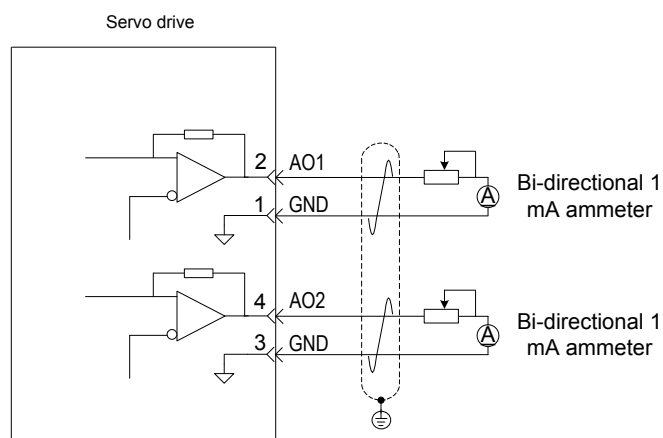

The monitored objects of analog signals are listed in the following table.

Table 3-35 Monitored objects of analog signals

Signal	Monitored Object
AO1	00: Motor speed, 01: Speed reference, 02: Torque reference, 03: Position deviation, 04: Position amplifier deviation, 05: Position reference speed, 06: Positioning completed reference, 07: Speed feedforward (H04-50/H04-53)
AO2	

Note	After the control power turns OFF, the analog monitoring output terminal may output around 5 V voltage for 50 ms at most. Take this into full consideration when using this terminal.
-------------	---

3.7 Anti-interference Measures for Electrical Wiring

Take the following measures to suppress interference:

- Ensure the length of the reference input cable is below 3 m, and the length of the encoder cable is below 20 m.
- Use a thick cable (above 2.0 mm²) as the grounding cable.
 - a. D class (or higher class) grounding is recommended (grounding resistance is below 100 Ω).
 - b. Use single point grounding.
- Use a noise filter to prevent radio frequency interference. In home application or application with noise interference, install the noise filter on the input side of the power supply line.
- To prevent malfunction due to electromagnetic interference, take the following measures:
 - a. Install the host controller and noise filter as close to the servo drive as possible.
 - b. Install a surge absorber on the relay, solenoid and electromagnetic contactor coils.
 - c. The distance between a strong-current cable and a weak-current cable must be at least 30 cm. Do not put these cables in the same duct or bundle them together.
 - d. Do not share the power supply with an electric welder or electrical discharge machine. When the servo drive is placed near a high-frequency generator, install a noise on the input side of the power supply line.

3

3.7.1 Anti-interference Wiring Example and Grounding

The servo drive uses high-speed switching element in the main circuit. Switching noise from these elements may affect normal operation of the servo drive due to improper wiring or grounding. Thus, the servo drive must be properly wired and grounded. A noise filter can be added if necessary.

1) Anti-interference wiring example

Figure 3-30 Anti-interference wiring example

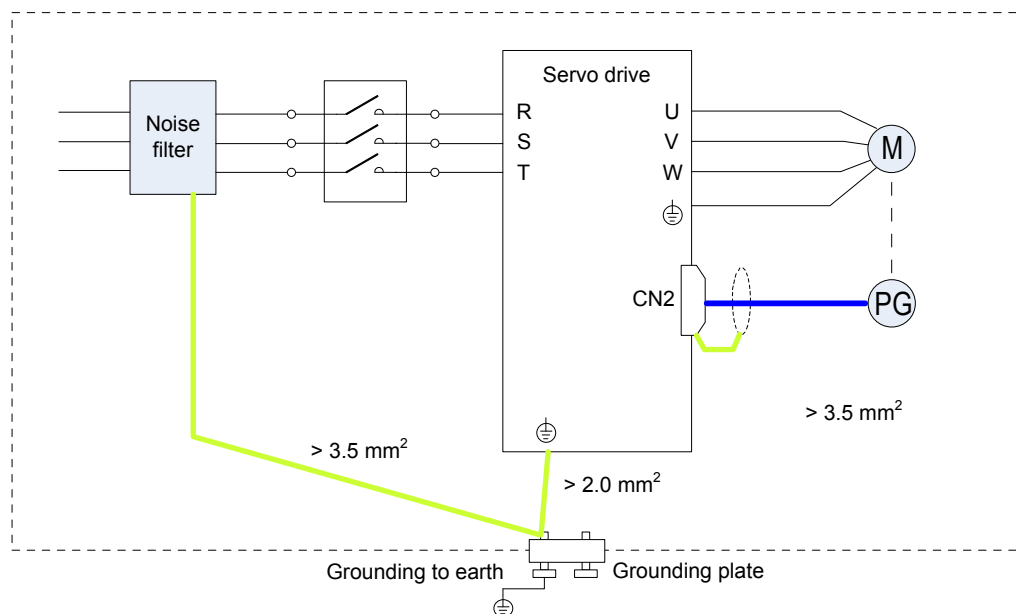

Note	<ol style="list-style-type: none"> 1. For the grounding cable connected to the cabinet housing, use a cable of at least 3.5 mm² thick. Plain stitch copper wires are recommended. 2. If a noise filter is used, observe the precautions as described in section 3.7.2.
-------------	---

2) Grounding

To prevent potential magnetic interference, conduct grounding correctly according to the following instructions.

a. Grounding the motor housing

Connect the grounding terminal of the servo motor to the PE terminal of the servo drive and ground the PE terminal, to reduce potential magnetic interference.

b. Grounding the shield of the encoder cable

Tie the shield of the motor encoder cable to ground at both ends.

3.7.2 Using Noise Filter

To prevent interference from power cables and reduce impact of the servo drive to other sensitive devices, install a noise filter on the input side of the power supply according to the input current. In addition, install a noise filter on the power supply line of peripheral devices if necessary. Observe the following precautions when installing and wiring the noise filter.

- 1) Do not put the input and output cables of the noise filter in the same duct or bundle them together.

Figure 3-31 Separate cabling of noise filter input and output cables

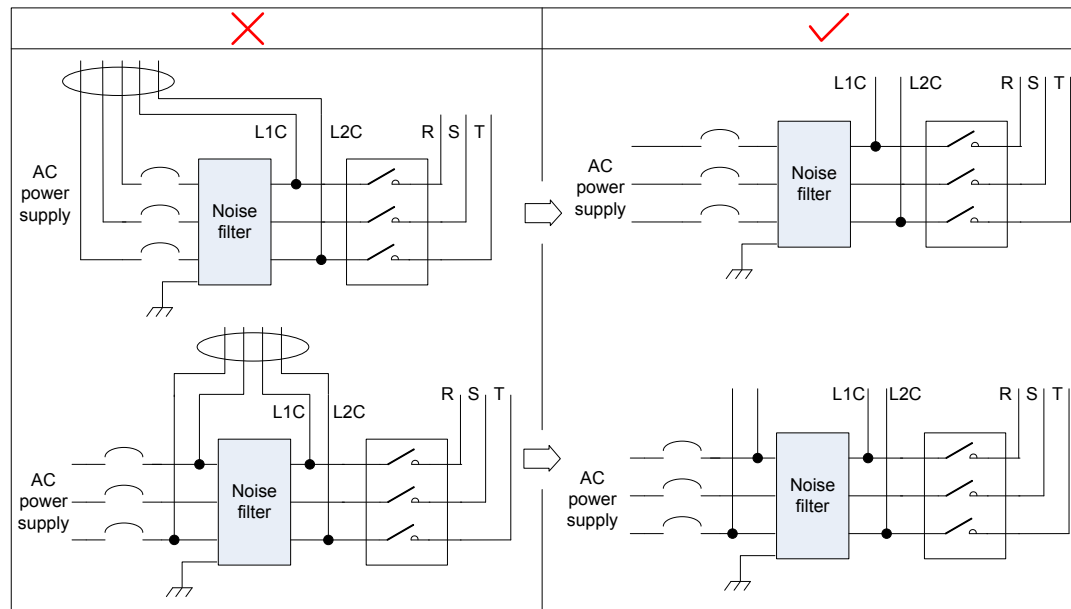

2) Separate the grounding wire and output power supply wires of the noise filter.

Figure 3-32 Separate cabling of noise filter grounding cable and output cable

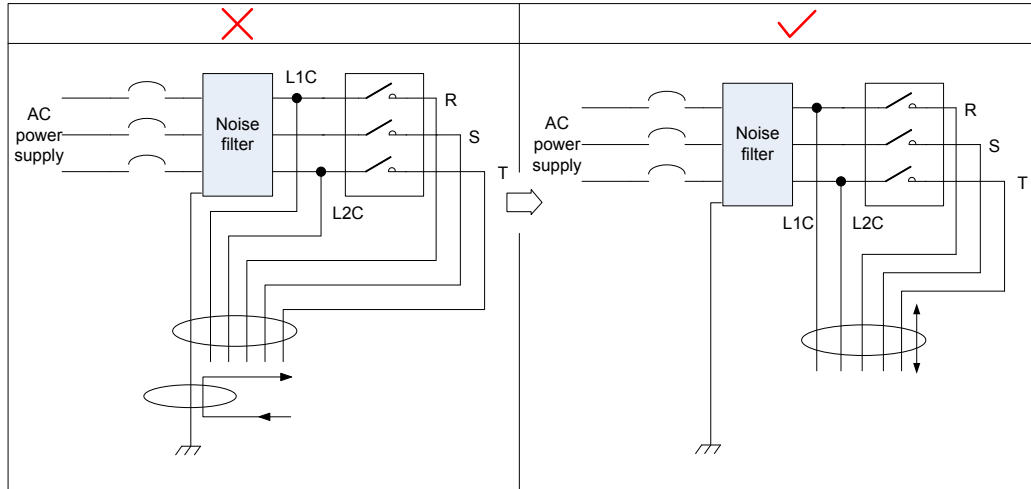

3) Use a separate grounding cable as short and thick as possible for the noise filter. Do not co-use the grounding cable for the noise filter and other grounding devices.

Figure 3-33 Single point grounding diagram

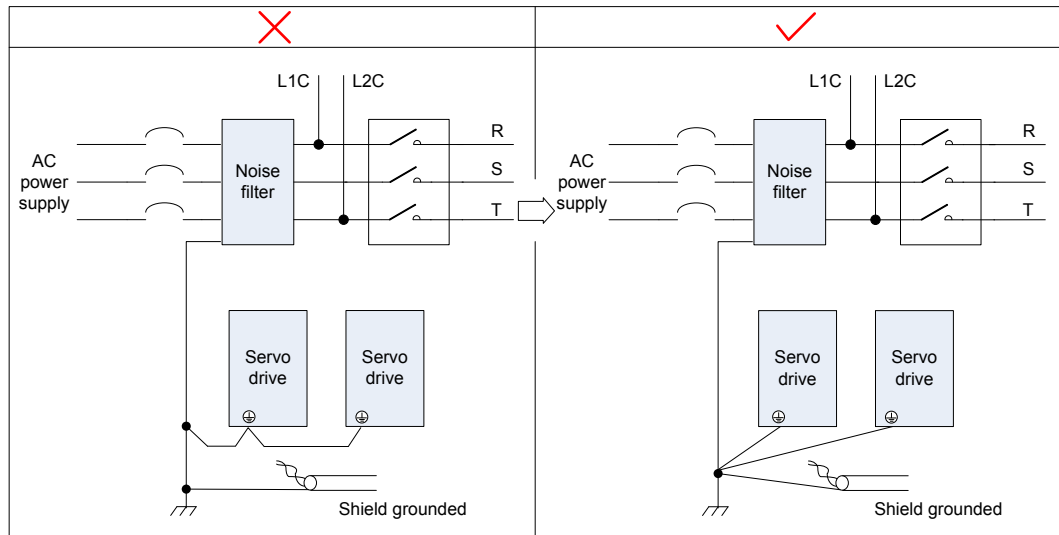

4) Grounding the noise filter inside the cabinet

If the noise filter and the servo drive are installed in the same cabinet, fix the noise filter and the servo drive on the same metal plate. Make sure the contact part is in good conductive condition, and ground the metal plate properly.

3

Figure 3-34 Noise filter grounding

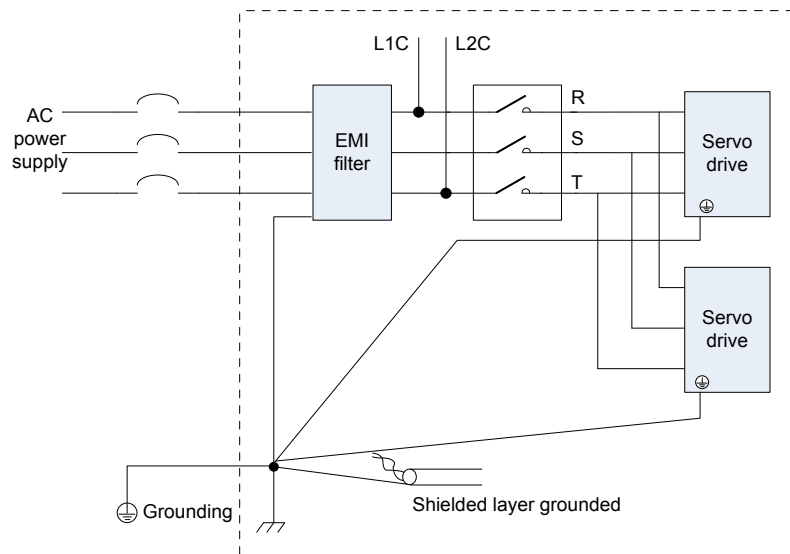

3.8 Precautions of Using Cables

Do not bend or apply stress to cables. The core wire of a signal cable is only 0.2 or 0.3 mm in diameter. Handle the cables carefully.

In scenarios where cables need to be moved, use flexible cables. Ordinary cables are easily damaged after being bent for a long time. Cables configured together with low power servo motors cannot be used for movement.

If the cable bear is used, make sure:

- The bending radius of the cable must be at least 10 times of its outer diameter.
- Do not fix or bundle the cables inside the cable bear. The cables can be bundled and fixed only at two unmovable ends of the cable bear.
- Cables must not be wound or warped.
- The space factor inside the cable bear must not exceed 60%.
- Do not mix cables of great difference in size. Otherwise, thick cables may crush thin cables. If thick and thin cables need to be used together, place a spacer plate to separate them.

Figure 3-35 Cable bear diagram

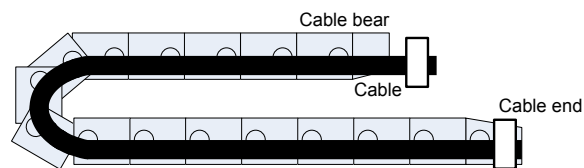

3.9 Wiring of Three Control Modes

Figure 3-36 Wiring of the position control mode

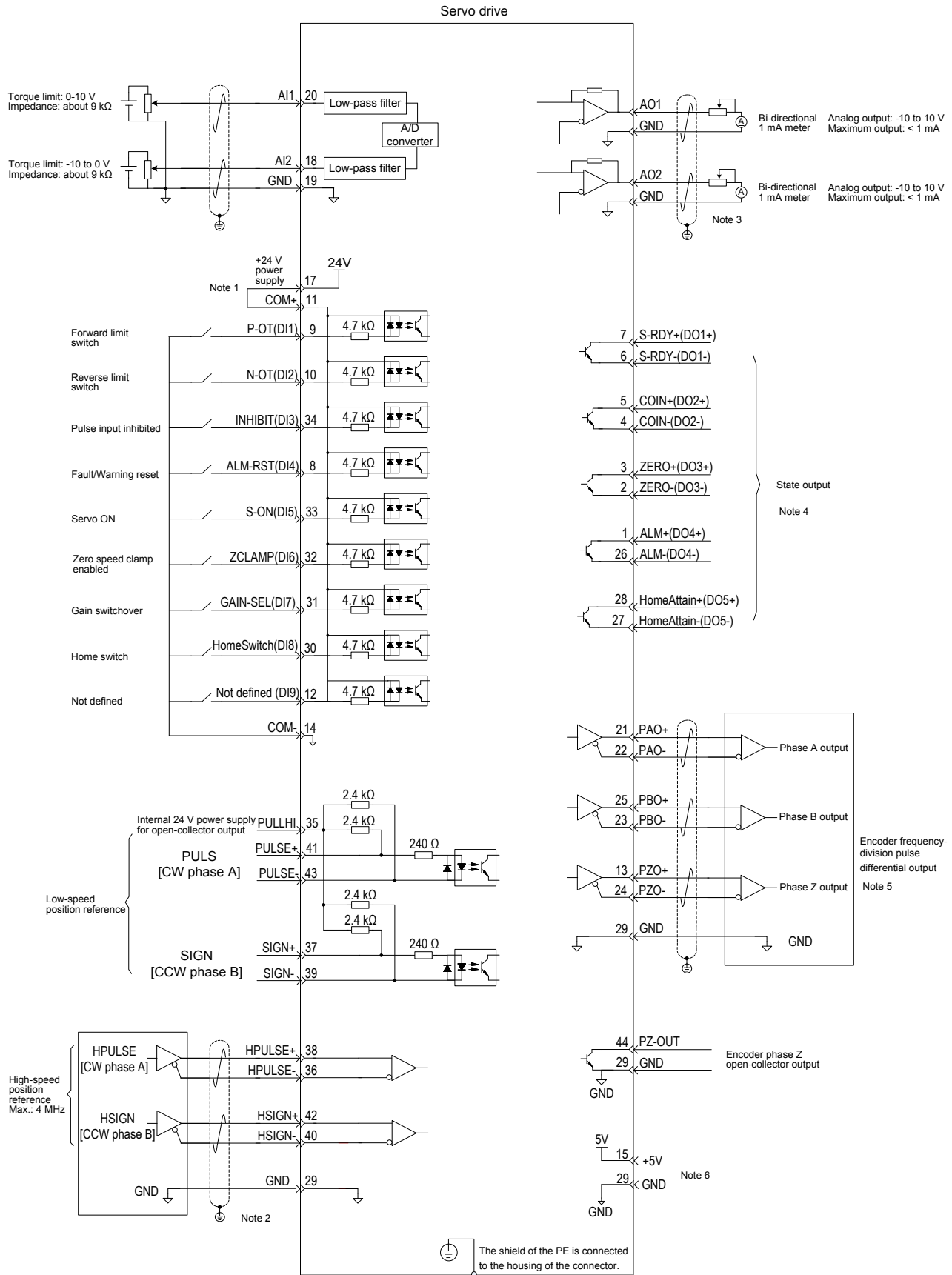

3

Note	<ol style="list-style-type: none">1. Use the shielded twisted-pair as the AI/AO circuit cables, with both ends of the shield tied to PE.2. Internal +24V power supply, voltage range: 20–28 V, maximum output current: 200 mA3. DI8 and DI9 are high-speed DIs. Use them according to their functions allocated.4. Use the shielded twisted-pair as the cables of the high-speed/low-speed pulse terminals, with both ends of the shield tied to PE. Connect GND and signal ground of the host controller reliably.5. Customers need to prepare the power supply for DOs, with voltage range 5–24 V. The DO terminals support 30 VDC voltage and 50 mA current to the maximum.6. Use the shielded twisted-pair as the encoder frequency-division cables, with both ends of the shield tied to PE. Connect GND and signal ground of the host controller reliably.7. The internal +5 V power supply supports a maximum of 200 mA current.
-------------	---

Figure 3-37 Wiring of the speed control mode

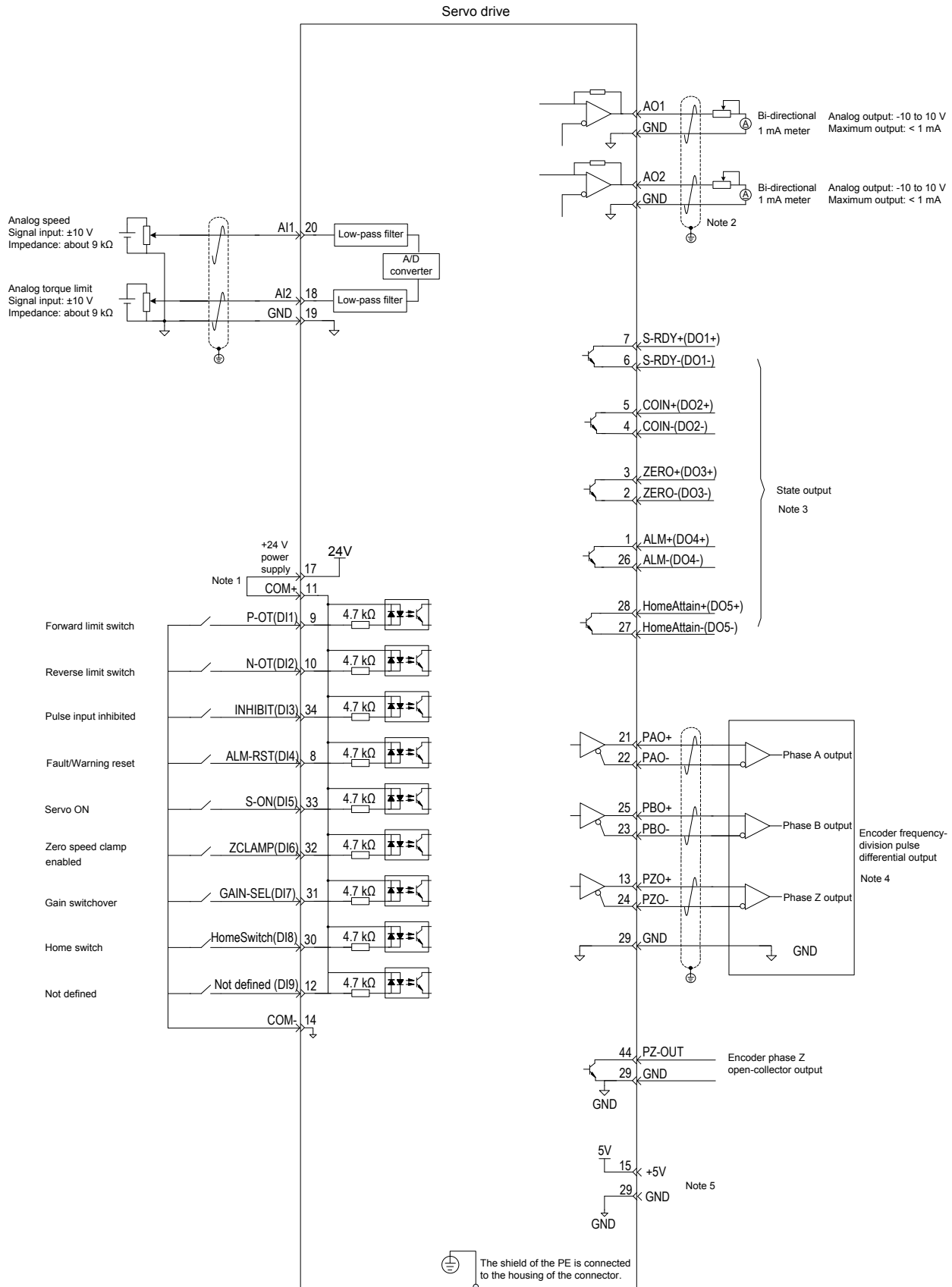

3

Note	<ol style="list-style-type: none">1. Internal +24V power supply, voltage range: 20–28 V, maximum output current: 200 mA2. DI8 and DI9 are high-speed DIs. Use them according to their functions allocated.3. Use the shielded twisted-pair as the AI/AO circuit cables, with both ends of the shield tied to PE.4. Customers need to prepare the power supply for DOs, with voltage range 5–24 V. The DO terminals support 30 VDC voltage and 50 mA current to the maximum.5. Use the shielded twisted-pair as the encoder frequency-division cables, with both ends of the shield tied to PE. Connect GND and signal ground of the host controller reliably.6. The internal +5 V power supply supports a maximum of 200 mA current.
-------------	---

Figure 3-38 Wiring of the torque control mode

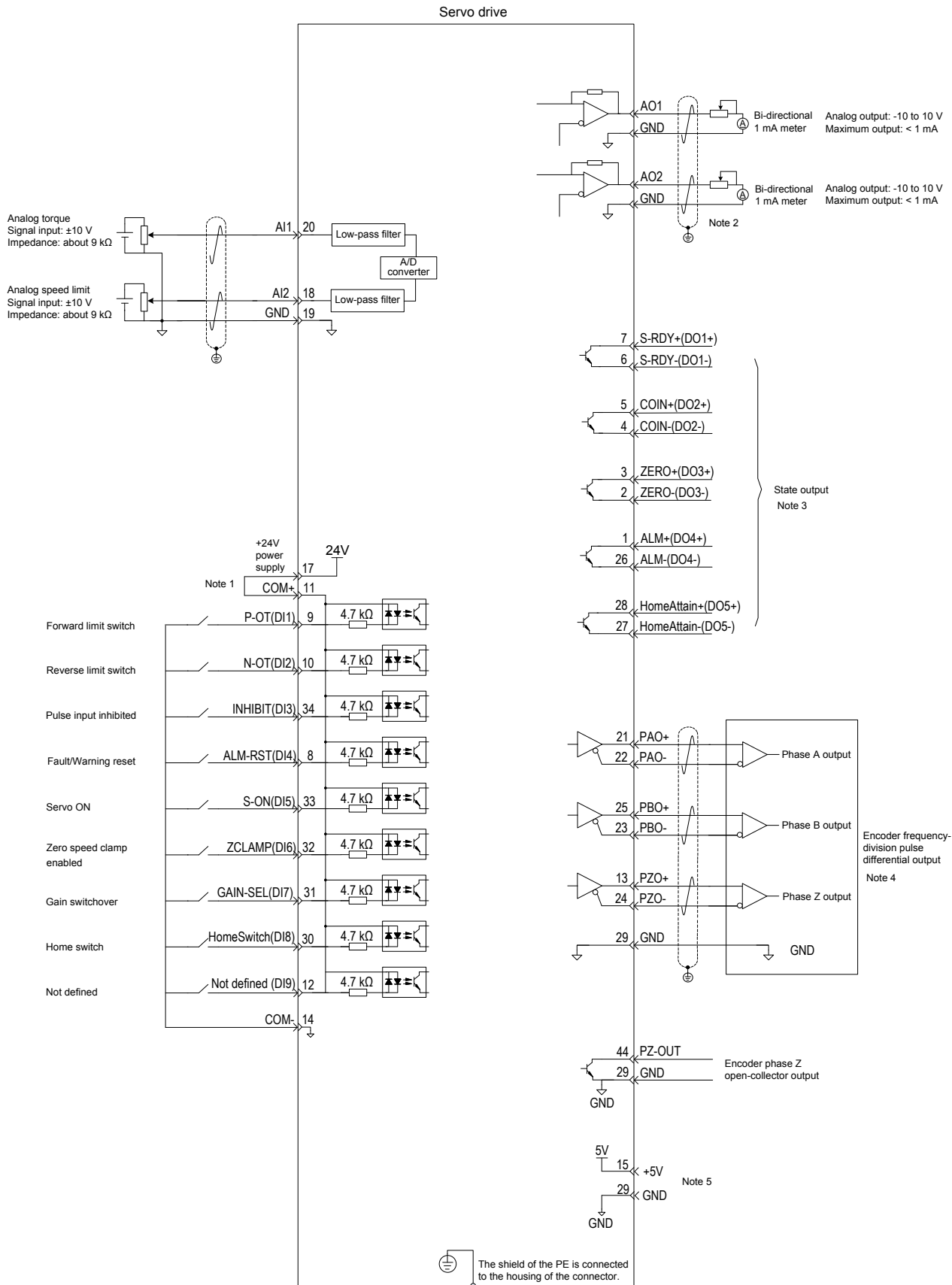

3

Note

1. Internal +24V power supply, voltage range: 20–28 V, maximum output current: 200 mA
2. DI8 and DI9 are high-speed DIs. Use them according to their functions allocated.
3. Use the shielded twisted-pair as the AI/AO circuit cables, with both ends of the shield tied to PE.
4. Customers need to prepare the power supply for DOs, with voltage range 5–24 V. The DO terminals support 30 VDC voltage and 50 mA current to the maximum.
5. Use the shielded twisted-pair as the encoder frequency-division cables, with both ends of the shield tied to PE. Connect GND and signal ground of the host controller reliably.
6. The internal +5 V power supply supports a maximum of 200 mA current.

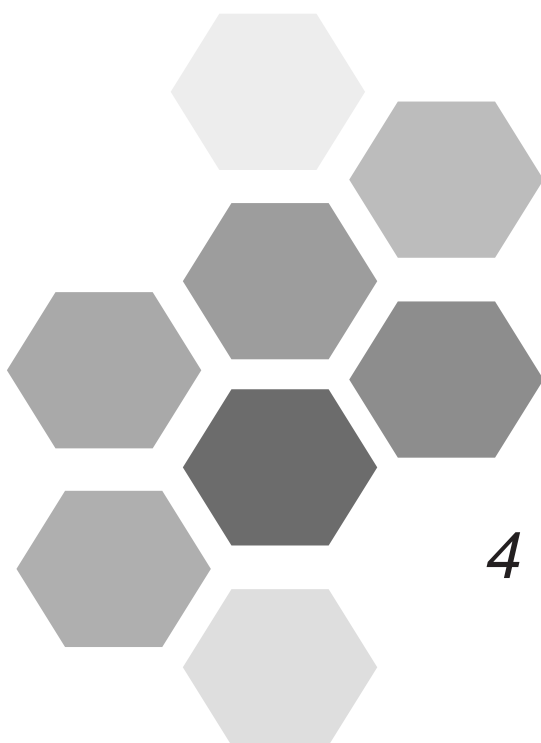

4 Operation and Display

4.1 Introduction to Keypad	110
4.2 Keypad Display	110
4.2.1 Display Switchover	111
4.2.2 Status Display	111
4.2.3 Parameter Display	112
4.2.4 Fault Display	113
4.2.5 Monitoring Display	114
4.3 Parameter Setting	122
4.4 User Password	123
4.5 Common Functions	124
4.5.1 Jog Running	124
4.5.2 Forced DI/DO Signal	125

Chapter 4 Operation and Display

4.1 Introduction to Keypad

Figure 4-1 Diagram of the keypad

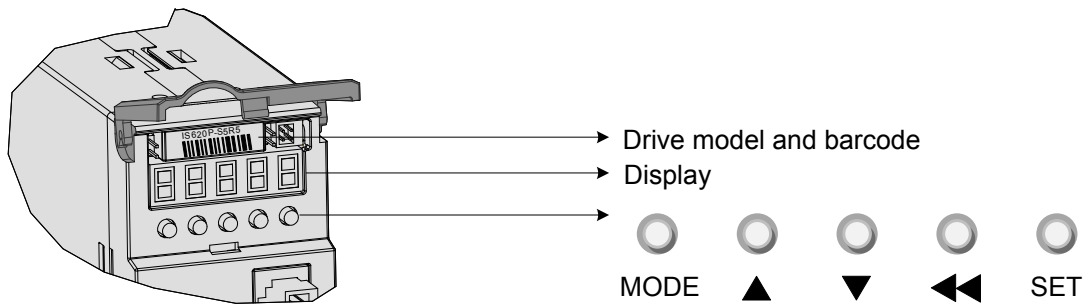

The keypad on the servo drive consists of the 5-digit 7-segment LEDs and keys. The keypad is used for display, parameter setting, user password setting and general functions operations. When the keypad is used for parameter setting, the functions of the keys are described as follows.

Table 4-1 Functions of keys on the keypad

Key Name	Function Description
MODE	Switch between all modes. Return to the upper-level menu.
UP	Increase the number indicated by the blinking digit.
DOWN	Decrease the number indicated by the blinking digit.
SHIFT	Shift the blinking digit. View the high digits of the number consisting of more than 5 digits.
SET	Switch to the next-level menu. Execute commands such as storing parameter setting value.

4.2 Keypad Display

The keypad can display the running status, parameter, faults, and monitored information during running of the servo drive.

- Status display: Displays the current servo drive status, such as servo ready or running.
- Parameter display: Displays function codes and their values.
- Fault display: Displays the fault and warnings occurring in the servo drive.
- Monitoring display: Displays the current running parameters of the servo drive.

4.2.1 Display Switchover

Figure 4-2 Switching between different display

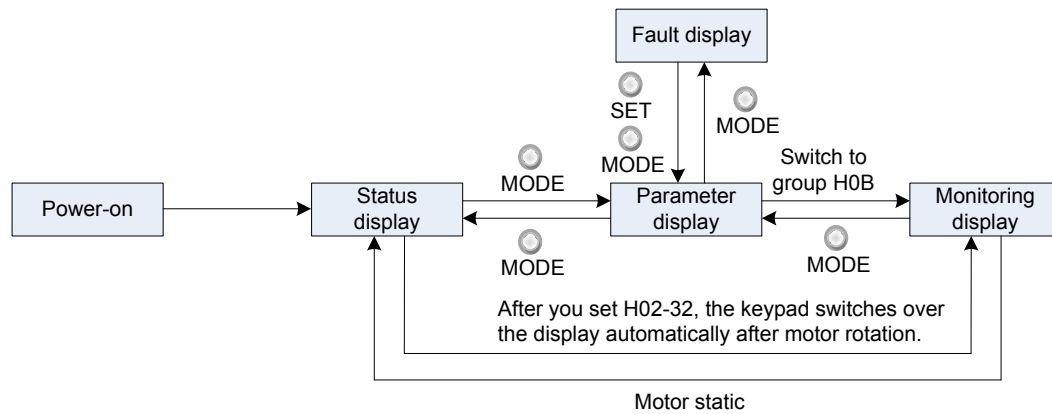

- After the power is on, the keypad enters the status display mode.
- Press key MODE to switch over between different modes, as shown in the preceding figure.
- In status display mode, set H02-32 and select the monitored parameters. When the motor rotates, the keypad automatically switches over to monitoring display. After the motor becomes stopped, the keypad automatically restores to status display.
- In parameter display mode, set group H0B and select the parameters to be monitored, and the keypad switches over to the monitoring display mode.
- Once a fault occurs, the keypad immediately enters the fault display mode, and all 5-digit LEDs blink. Press key SET to stop blinking, and then press key MODE to switch over to the parameter display mode.

4.2.2 Status Display

Display	Name	Condition	Meaning
	Reset Servo initialization	Moment at servo power-on	The servo drive is in initialization or reset state. After initialization or reset is completed, the servo drive automatically switches over to another state.
	Nrd Servo not ready	Initialization is completed, but the servo drive is not ready.	The main circuit is not powered on, and the servo drive is not ready for running. For details, refer to Chapter 8.
	Rdy Servo ready	The servo drive is ready.	The servo drive is ready for running, and waits for the S-ON signal from the host controller.
	Run Servo being running	The servo ON (S-ON) signal is active.	The servo drive is in running state.
	Jog Jog running	The servo drive is in jog running state.	For details, refer to section 5.1.3.

4.2.3 Parameter Display

The servo drive has 19 function groups based on parameter functions. The function code can be located quickly based on the group it belongs to. Refer to Chapter 7 to view the function code table.

1) Function code group

Display	Name	Description
HXX.YY	Function code group	XX: function code group YY: function code No.

For example, H02-00 is displayed as follows:

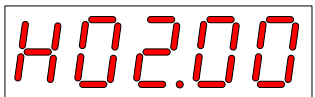
Display	Name	Description
	Function code H02-00	02: function code group 00: function code No.

2) Display of data of different lengths and negative number

a. With-symbol number of 4 digits and below and without-symbol number of 5 digits and below

Such a number is displayed with a single page (5 LEDs). The highest digit "-" indicates the negative symbol.

For example, -9999 is displayed as follows:

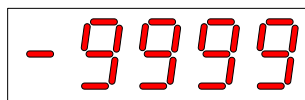

For example, 65535 is displayed as follows:

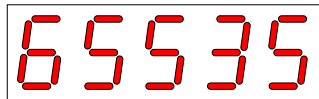

b. With-symbol number of above 4 digits and without-symbol number of above 5 digits

The number is displayed in digits from low to high in pages. Each five digits are displayed in a page. The display method is: current page + value on current page. As shown in the following figure, hold down SHIFT for more than two seconds to switch to the next page.

For example, -1073741824 is displayed as follows:

Figure 4-3 -1073741824 display operation diagram

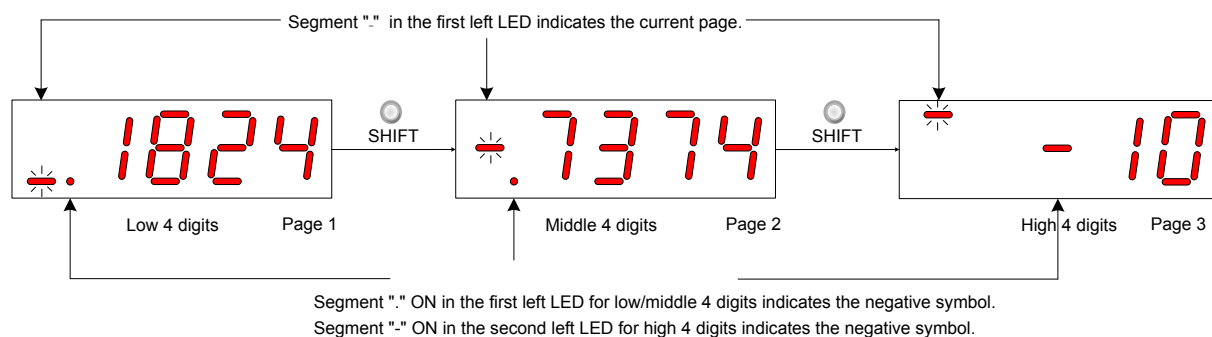

For example, 1073741824 is displayed as follows:

Figure 4-4 1073741824 display operation diagram

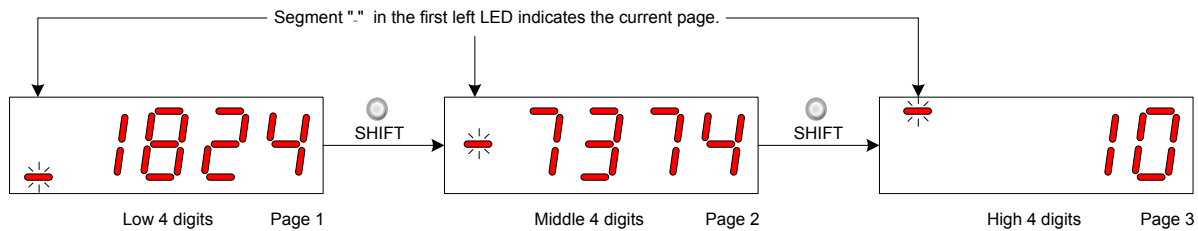

3) Decimal point display

Segment "." of the unit's digit indicates the decimal point, and this segment does not blink.

Display	Name	Content
	Decimal point	100.0

4) Parameter setting display

Display	Name	Display Scenario	Meaning
	Done Parameter setting completed	Parameter setting is successful.	The parameter setting is completed and stored in the servo drive. Then, the servo drive can execute other operations.
	F.InIt Parameter restored to default setting	The parameter initialization function is used (H02-31 = 1).	The servo drive executes parameter initialization. After initialization is completed, the control power is on again.
	Error Password incorrect	When the user password function (H02-30) is used, the password entered is incorrect.	The servo drive prompts entered password error, and you need to enter the correct password.

4

4.2.4 Fault Display

- The keypad displays the current or history faults and warnings. For analysis and rectification of faults and warnings, refer to Chapter 8.
- When a single fault or warning occurs, the keypad displays the fault or warning code. When multiple faults or warnings occur, the keypad displays the fault code of the highest level.
- Set in H0B-33 the history fault to be viewed. View H0B-34 to display the select fault or warning codes.
- Set H02-31 to 2 to clear information about latest 10 faults or warnings stored in the servo drive.

For example, Er.941 is displayed as follows:

Display	Name	Content
	Current warning code	Er: indicates fault or warning in the servo drive 941: fault or warning code







4.2.5 Monitoring Display

Group H0B: Displays the parameters for monitoring the running status of the servo drive.





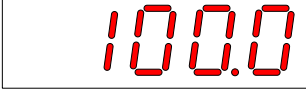

Set H02-32 (Default keypad display). After the servo motor runs properly, the keypad switches over from servo status display mode to parameter display mode and displays the parameters set in H0B-32.

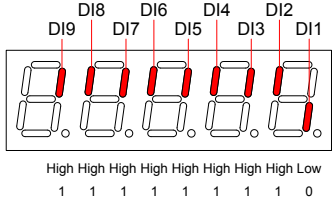
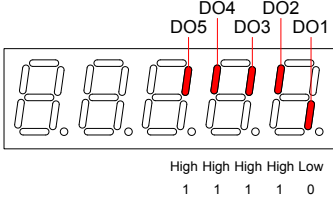
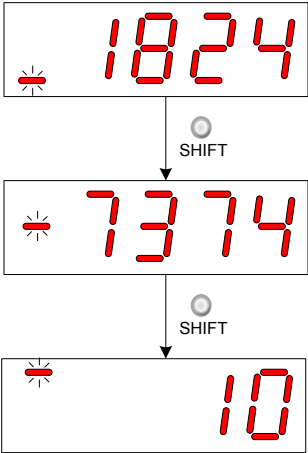

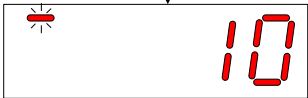

For example, if H02-32 = 00, the keypad displays the value of H0B-00 when the servo motor speed is not 0.

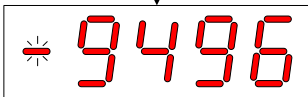
The H0B display is described as follows:

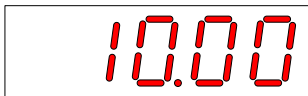
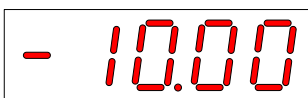

Function Code	Parameter Name	Unit	Meaning	Display Example
H0B-00	Actual motor speed	RPM	It displays the actual motor speed after round-off, in unit of 1 RPM.	3000 RPM display:  -3000 RPM display: 
H0B-01	Speed reference	RPM	It displays the current speed reference of the servo drive.	3000 RPM display:  -3000 RPM display: 
H0B-02	Internal torque reference	0.1%	It displays the percentage of the actual motor output torque to the rated motor torque.	100.0% display:  -100.0% display: 

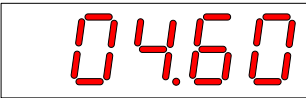
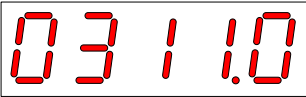
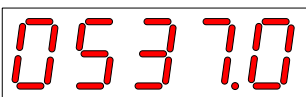
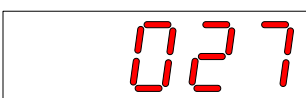
Function Code	Parameter Name	Unit	Meaning	Display Example
H0B-03	Monitored DI states	-	<p>It displays the level states of the nine DI terminals:</p> <p>The upper LED segment ON indicates high level (expressed by "1").</p> <p>The lower LED segment ON indicates low level (expressed by "0").</p> <p>H0B-03 value read by the background software is a decimal number.</p>	<p>For example, if DI1 is low level and DI2 to DI9 are high level:</p> <p>The binary value is 111111110;</p> <p>The value of H0B-03 read by the background software is 510.</p> <p>The keypad display is as follows:</p> 
H0B-05	Monitored DO states	-	<p>It displays the level states of the five DI terminals:</p> <p>The upper LED segment ON indicates high level (expressed by 1).</p> <p>The lower LED segment ON indicates low level (expressed by 0).</p> <p>H0B-05 value read by the background software is a decimal number.</p>	<p>For example, if DO1 is low level and DO2 to DO5 are high level:</p> <p>The binary value is 11110;</p> <p>The value of H0B-05 read by the background software is 30.</p> <p>The keypad display is as follows:</p> 
H0B-07	Absolute position counter (32-bit decimal display)	Reference unit	<p>It displays the current absolute motor position (reference unit).</p>	<p>1073741824 referent units display:</p> 

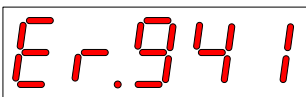

Function Code	Parameter Name	Unit	Meaning	Display Example
H0B-15	Encoder position deviation counter (32-bit decimal display)	Encoder unit	Encoder position deviation = Input position reference sum (encoder unit) – Total encoder feedback pluses (encoder unit)	10000 encoder units display: 
H0B-17	Feedback pulse counter (32-bit decimal display)	Encoder unit	It displays counts and displays the pulses fed back by the servo motor encoder (encoder unit).	1073741824 encoder units display:  SHIFT  SHIFT 
H0B-19	Total power-on time (32-bit decimal display)	0.1s	It displays counts and displays the total servo drive power-on time.	429496729.5s display  Hold down SHIFT  Hold down SHIFT 
H0B-21	AI1 sampling voltage	0.01 V	It displays the voltage of analog input 1.	10.00 V display:  -10.00 V display: 

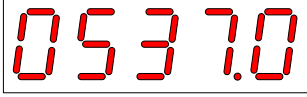
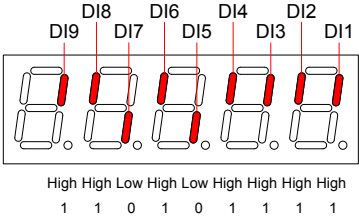
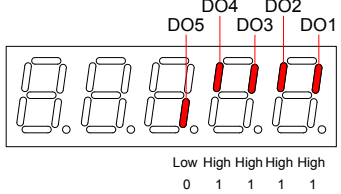
Function Code	Parameter Name	Unit	Meaning	Display Example
H0B-22	AI2 sampling voltage	0.01 V	It displays the voltage of analog input 2.	10.00 V display:  -10.00 V display: 
H0B-24	Phase current effective value	0.01 A	It displays the phase current effective value of the servo motor.	4.60 A display: 
H0B-26	Bus voltage	0.1 V	It displays the DC bus voltage of the main circuit, that is, voltage between terminals P ₊ and ⊖.	311.0 V display rectified from 220 VAC:  537.0 V display rectified from 380 VAC 
H0B-27	Module temperature	°C	It displays the temperature of the power module inside the servo drive.	27°C display: 
H0B-33	Fault record	-	It sets the history fault to be viewed. 0: Current fault 1: Last fault 2: Last 2nd fault 9: Last 9th fault	0: Current fault display 
H0B-34	Fault code of selected fault record	-	It displays the fault code selected by H0B-33. When there is no fault, H0B-34 display is "Er.000".	If H0B-33 = 0, H0B-34 = Er.941, the current fault code is 941. Display: 

Function Code	Parameter Name	Unit	Meaning	Display Example
H0B-35	Time stamp upon displayed fault	s	It displays the total servo running time when the fault displayed in H0B-34 occurs. When there is no fault, H0B-35 display is "0".	<p>If H0B-34 = Er.941, H0B-35 = 107374182.4, the current fault code is 941 and the total servo running time is 107374182.4s when this fault occurs.</p>
H0B-37	Current motor speed upon displayed fault	RPM	It displays the servo motor speed when the fault displayed in H0B-34 occurs. When there is no fault, H0B-37 display is "0".	<p>3000 RPM display:</p> <p>-3000 RPM display:</p>
H0B-38	Motor phase U current upon displayed fault	0.01 A	It displays the winding current effective value of the servo motor phase U when the fault displayed in H0B-34 occurs. When there is no fault, H0B-38 display is "0".	<p>4.60 A display:</p>
H0B-39	Motor phase V current upon displayed fault	0.01 A	It displays the winding current effective value of the servo motor phase V when the fault displayed in H0B-34 occurs. When there is no fault, H0B-39 display is "0".	<p>4.60 A display:</p>

Function Code	Parameter Name	Unit	Meaning	Display Example
H0B-40	Bus voltage upon displayed fault	V	It displays the DC bus voltage of the main circuit when the fault displayed in H0B-34 occurs. When there is no fault, H0B-40 display is "0".	311.0 V display rectified from 220 VAC:  537.0 V display rectified from 380 VAC 
H0B-41	Input terminal state upon displayed fault	-	It displays the high/level state of the nine DI terminals when the fault displayed in H0B-34 occurs. The viewing method is the same as that of H0B-03. When there is no fault, H0B-41 displays that all DI terminals is low level, corresponding to the decimal value 0.	H0B-41 = 431 display: 
H0B-42	Output terminal state upon displayed fault	-	It displays the high/level state of the five DO terminals when the fault displayed in H0B-34 occurs. The viewing method is the same as that of H0B-05. When there is no fault, H0B-42 displays that all DO terminals is low level, corresponding to the decimal value 0.	H0B-42 = 15 display: 
H0B-53	Position deviation counter (32-bit decimal display)	Reference unit	Position deviation = Input position reference sum (reference unit) – Total encoder feedback pluses (reference unit)	10000 reference units display: 

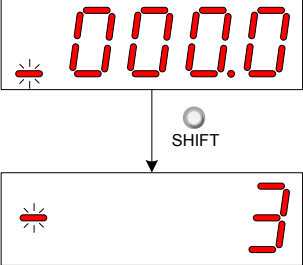
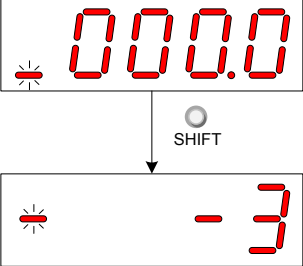
4

Function Code	Parameter Name	Unit	Meaning	Display Example
H0B-55	Actual motor speed	0.1 RPM	It displays the actual motor speed, in unit of 0.1 RPM.	<p>3000.0 RPM display:</p>  <p>-3000.0 RPM display:</p> 
H0B-64	Real-time input position reference counter	Reference unit	It displays the position reference counter before divided or multiplied by the electronic gear ratio. It is irrelative to the current servo state and control mode.	<p>3000 RPM display:</p>  <p>-3000 RPM display:</p> 

4.3 Parameter Setting

Parameter setting can be performed on the keypad. For details on the parameters, refer to Chapter 7. The following figure shows the keypad operation of switching the position control mode to the speed control mode after the power is on.

Figure 4-5 Keypad operation of parameter setting

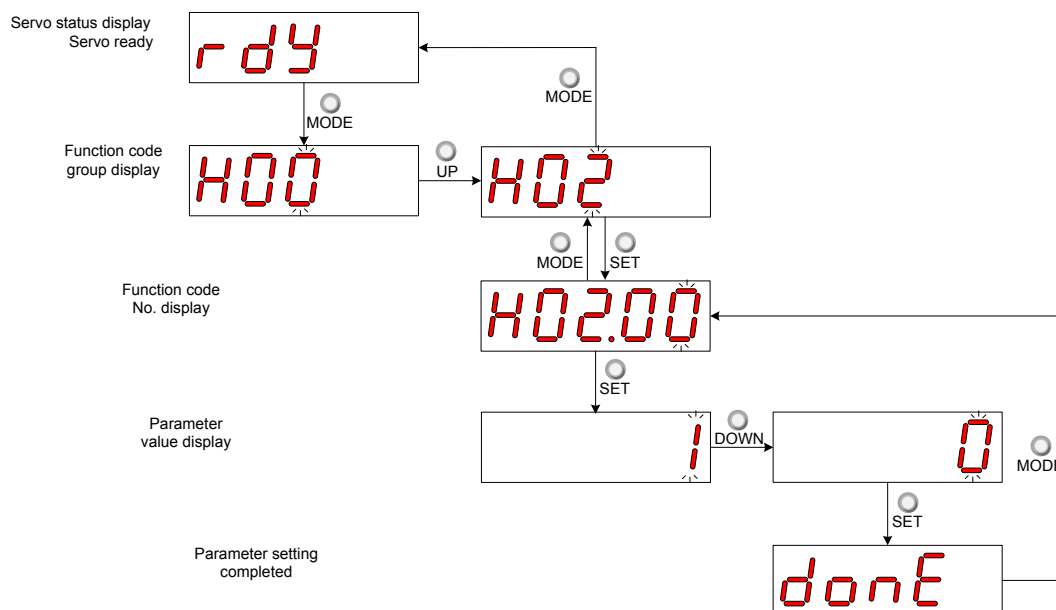

- **MODE:** Switch the display mode and return to the upper-level menu.
- **UP/DOWN:** Increase or decrease the value of the current blinking digit.
- **SHIFT:** Shifting the blinking digit.
- **SET:** Store the current setting value or switch to the next-level menu.

After parameter setting is completed, that is, "Done" is displayed, press key MODE to return to the parameter group display (H02-00).

4.4 User Password

After the user password function (H02-30) is enabled, only the authorized user has the parameter setting rights; other operations can only view the parameters.

1) Setting user password

The following figure shows the operation procedure of setting the password to "00001".

Figure 4-6 Keypad operation of user password setting

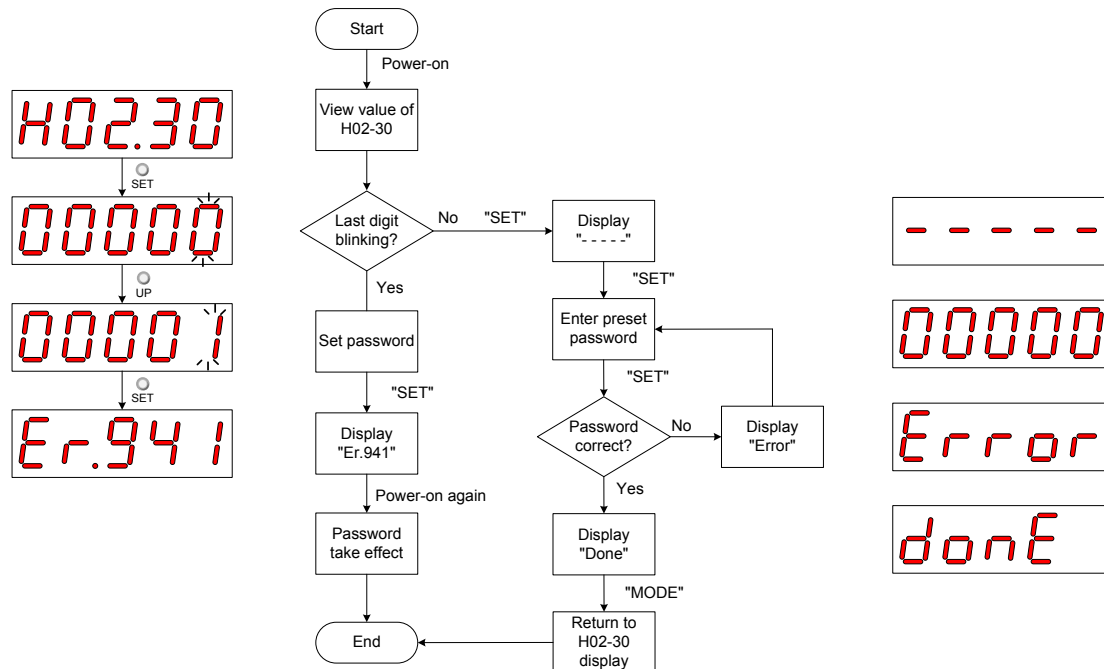

Note

*1: If the last digit does not blink, password protection is enabled. If the last digit blinks, password protection is disabled or the correct password has been entered.

When modifying the user password, enter the correct password so that you have the rights of parameter setting. Enter H02-30 again, and you can set a new password according to the method described in the preceding figure.

2) Canceling user password

Enter the existing user password, and set H02-30 to "00000". Then, the user password is cancelled.

4.5 Common Functions

4.5.1 Jog Running



When using the jog function, set the S-ON signal inactive. Otherwise, this function cannot be used.

Use the jog running function to perform trial running on the servo motor and drive.

1) Operation method

Figure 4-7 Keypad operation of jog running setting

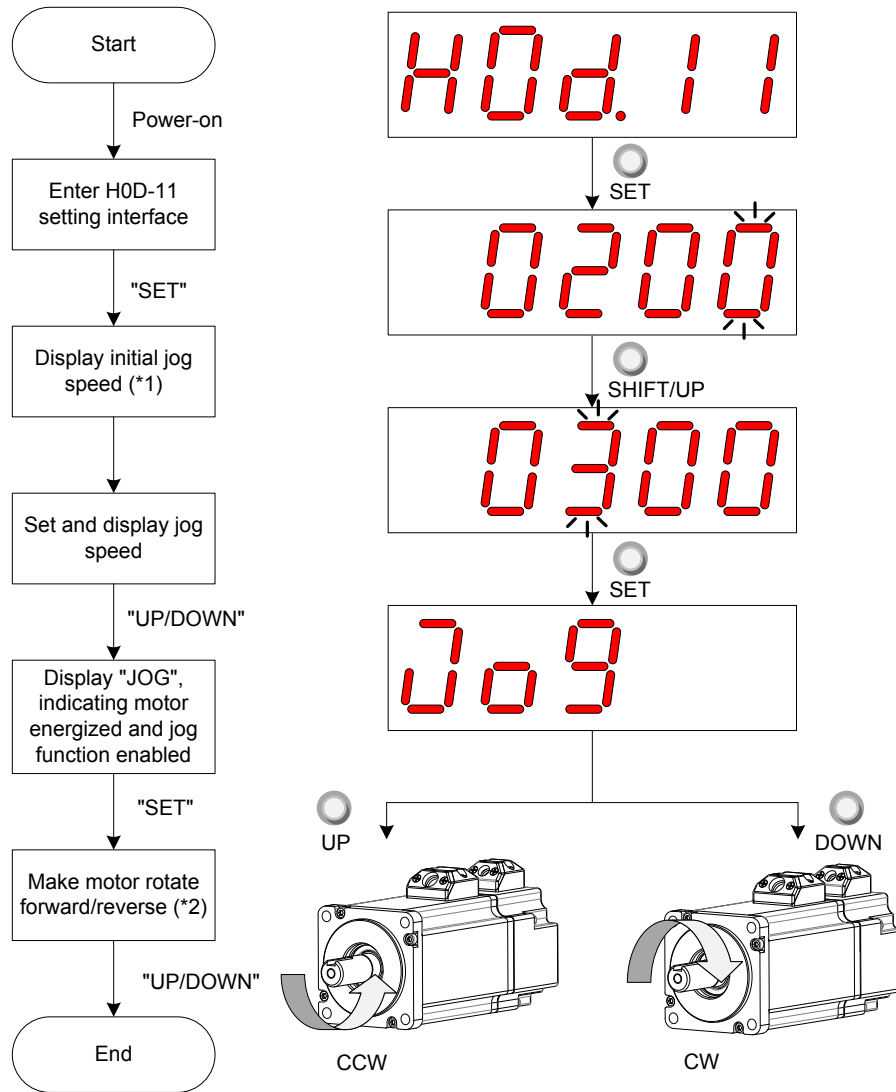

Note

*1: Press key UP or DOWN to increase or decrease the motor speed for the jog running. If the system exits jog running, the motor speed restores to the initial value.

*2: Press key UP or DOWN to make the servo motor rotates in forward or reverse direction. After you release the key, the servo motor stops running immediately.

2) Exiting jog running

Press key MODE to exit the jog running and return to the upper-level menu.

4.5.2 Forced DI/DO Signal

The DI and DO signals can be allocated with functions by setting group H03 and H04 parameters via keypad or host controller communication. Then, the host controller can control functions of the servo drive via DIs and the servo drive outputs DO signals to the host controller.

The servo drive also provides the forced DI/DO signal function. The forced DI signal can be used to test the DI function of the servo drive, and the forced DO signal can be used to check DO signal connection between the host controller and the servo drive.

When forced DI/DO is used, the logics of both physical DIs and VDIs are determined by forced input.

1) Forced DI signal

After this function is enabled, all DI levels are controlled by forced input (H0D-18), and are irrelative to the external DI signal state.

a. Operation method

Figure 4-8 Forced DI signal setting procedure

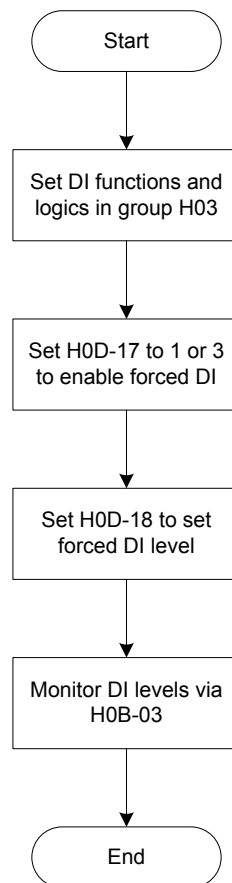

Relevant parameters:

Function Code	Parameter Name	Setting Range	Function	Property	Effective Time	Default
H0D-17	Forced DI/DO setting	0: Disabled 1: Forced DI enabled, forced DO disabled 2: Forced DO enabled, forced DI disabled 3: Forced DI and DO enabled	Select the forced DI/DO function.	During running	Immediate	0

H0D-18 sets the forced DI level. The keypad displays the value in hexadecimal, and needs to be converted to binary for viewing: "1" indicating high level and "0" indicating low level.

Group H03 parameters set the DI logics. H0B-03 monitors the DI level states. The value displayed on the keypad is directly the level and that read from the background software is a decimal number.

Example:

If it is required that the DI1 function is valid and functions allocated to DI2 to DI9 are invalid (all the DIs are low level active), set as follows:

"1" indicates high level and "0" indicates low level, and the binary value is 11111110, corresponding to hexadecimal 1FE. Set H0D-18 to "1FE" on the keypad.

Figure 4-9 Setting H0D-18

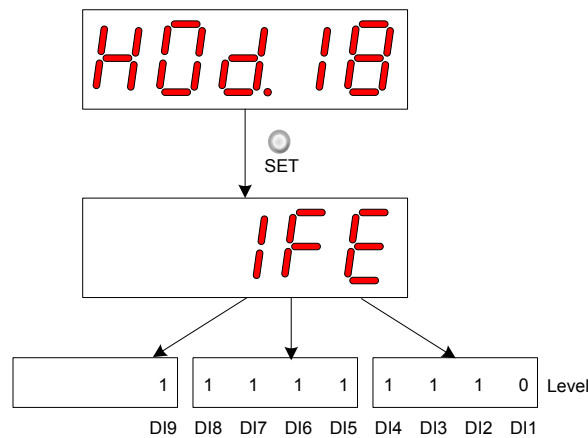

Monitor the DI level states via H0B-03 as follows:

If DIs are normal, H0B-03 display value is always the same as H0D-18 display value.

That is, DI1 is low level and DI2 to DI9 are high level on the keypad display, and H0B-03 value read from the background software is 510 (decimal).The keypad display is as follows:

Figure 4-10 DI level states in H0B-03

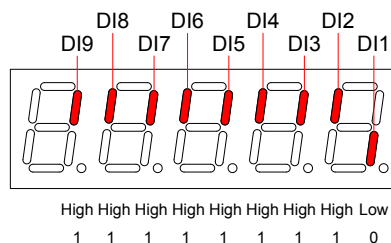

b. Exiting forced DI function

This function is not retentive upon power-off. Normal DI functions are restored after power-on again, or you can set H0D-17 to 0 to switch back to normal DI mode.

2) Forced DO signal

After this function is enabled, all DO levels are controlled by forced output (H0D-19), and are irrelative to the external DI signal state.



In applications where the servo motor drives the vertical axis, when the brake output signal (FunOUT.9: BK, brake output) is active, the brake will be released and the load may fall. Take protection measures against falling on the machine.

a. Operation method

Figure 4-11 Forced DO signal setting procedure

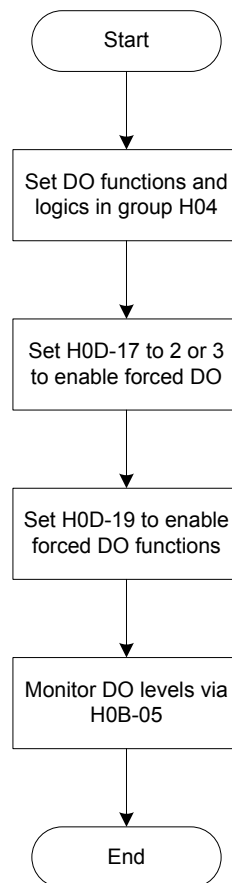

4

H0D-19 sets whether the forced DO functions are valid. The keypad displays the value in hexadecimal, and needs to be converted to binary for viewing: "1" indicating DO function valid and "0" indicating DO function invalid.

Group H04 parameters set the DO logics. H0B-05 monitors the DO level states. The value displayed on the keypad is directly the level and that read from the background software is a decimal number.

Example:

If it is required that the DO1 function is invalid and functions allocated to DI2 to DI5 are valid, set as follows:

"1" indicates DO function valid and "0" indicates DO function invalid, and the binary value is 11110, corresponding to hexadecimal 1E. Set H0D-19 to "1E" on the keypad.

Figure 4-12 Setting H0D-19

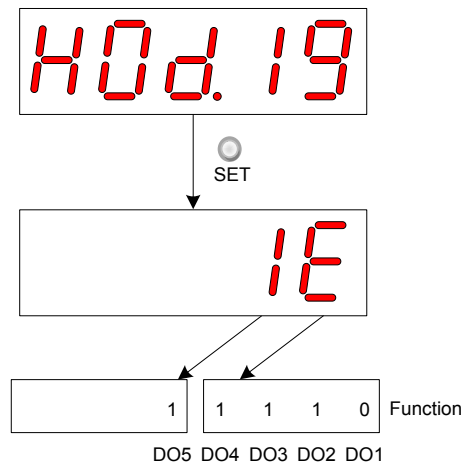

Monitor the DO level states via H0B-05 as follows:

If the logics of all five DOs are low level active, DO1 is high level and DO2 to DO5 are low level, the corresponding binary is 00001 and the value read from the background software is 1 (decimal). The keypad display is as follows:

Figure 4-13 H0B-05 display when all DOs are low level active

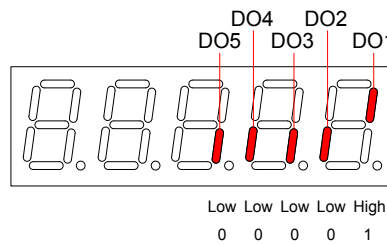

If the logics of all five DOs are high level active, DO1 is low level and DO2 to DO5 are high level, the corresponding binary is 11110 and the value read from the background software is 30 (decimal). The keypad display is as follows:

Figure 4-14 H0B-05 display when all DOs are high level active

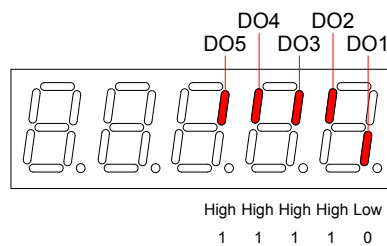

b. Exiting forced DO function

This function is not retentive upon power-off. Normal DO functions are restored after power-on again, or you can set H0D-17 to 0 to switch back to normal DO mode.



5 Control Modes

5.1 Basic Setting	131
5.2 Position Control Mode	156
5.3 Speed Control Mode	207
5.4 Torque Control Mode	230
5.5 Hybrid Control Mode	253
5.6 Descriptions of Absolute System	254
5.7 Auxiliary Functions	261

Chapter 5 Control Modes

The servo system consists of three major parts, servo drive, servo motor, and encoder.

Figure 5-1 Control block diagram of servo system

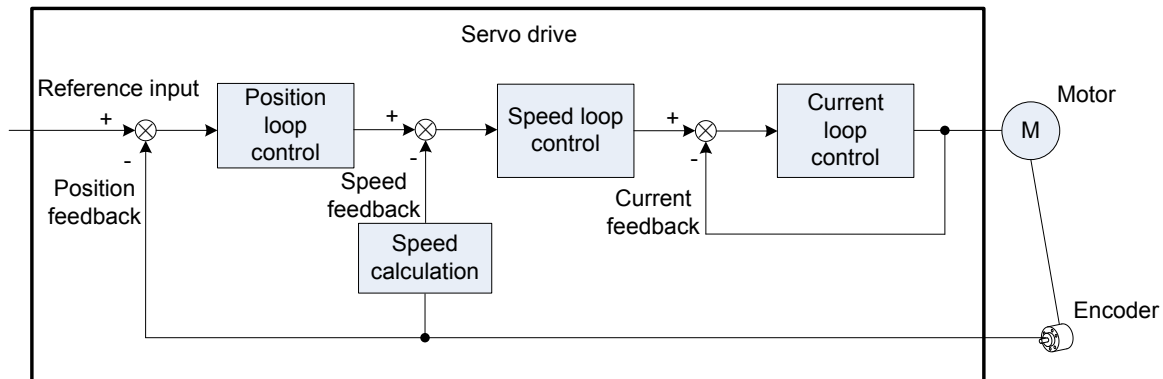

As the control core of the servo system, the servo drive performs accurate position, speed, torque, or hybrid control on the servo motor by processing the input signals and feedback signals. Position control is the most important and common mode of the servo system.

Descriptions of the control modes are as follows:

- Position control

The servo drive controls the motor position based on position references. The position reference sum determines the target motor position, and the position reference frequency determines the motor speed. The position references can be input via external pulses or internal position reference sum plus speed limit. With use of the internal encoder (that of the servo motor) or external encoder (full closed-loop control), the servo drive implements quick and accurate control on the mechanical position and speed. This control mode is applicable to scenarios requiring positioning control, such as mechanical arm, mounter, engraving and milling machine (pulse sequence reference), and computer numerical control (CNC) machine tool.

- Speed control

The servo drive controls the mechanical speed based on speed references.

Speed references are input via digital setting, analog voltage, or communication.

This control mode is applicable to scenarios in which speed control is required or the host controller outputs speed references to the servo drive during position control. An application example is analog engraving and milling machine.

- Torque control

Torque control is operated by controlling the current, as the current is in linear relationship with the torque. The servo drive controls the motor output torque based on torque references. Torque references are input via digital setting, analog voltage, or communication. This control mode is mainly applicable to the winding and unwinding devices with strict tension requirements. In these scenarios, the torque always changes with the winding radius so that the tension will not change along with the change of the winding radius.

5.1 Basic Setting

Figure 5-2 Servo drive setting flowchart

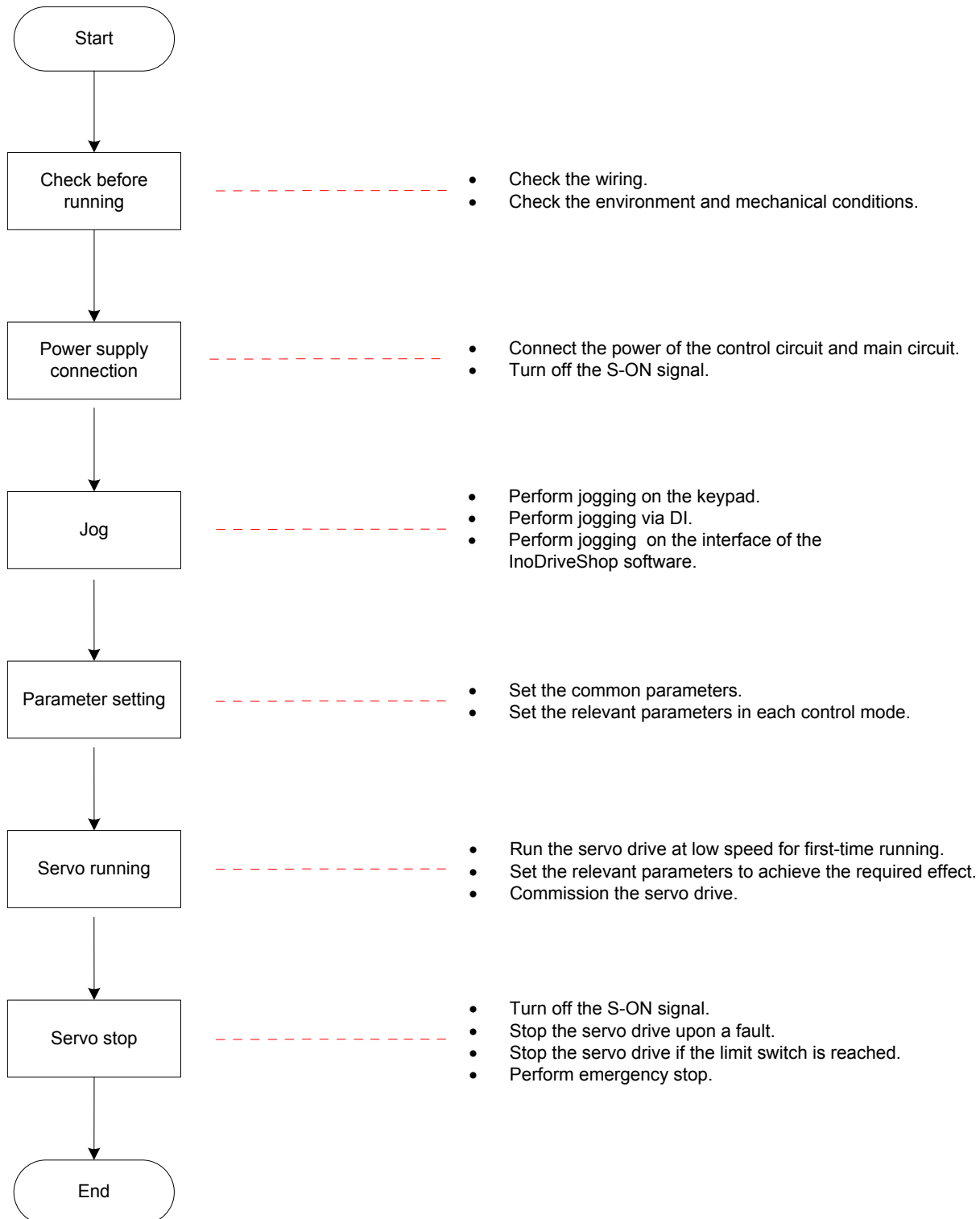

5.1.1 Check Before Running

Check the items in the following table before running the servo drive and motor.

Table 5-1 Checklist before running

Applicable	Item	Activity
Wiring		
<input type="checkbox"/>	1	The servo drive's control circuit power input terminals L1C, L2C and main circuit power input terminals R, S, T are connected correctly.
<input type="checkbox"/>	2	The main circuit output terminals U, V, W of the servo drive are properly connected to the power cables U, V, W of the servo motor in correct phase sequence.
<input type="checkbox"/>	3	No short circuit exists in the main circuit power input terminals R, S, T and output terminals U, V, W of the servo drive.
<input type="checkbox"/>	4	The signal wires of the servo drive are connected correctly. The external signal wires such as brake and limit switch are connected reliably.
<input type="checkbox"/>	5	The servo drive and motor are grounded reliably.
<input type="checkbox"/>	6	The jumper between terminals P _⊕ and D has been removed when the external regenerative resistor is used.
<input type="checkbox"/>	7	The cable tension is within the permissible range.
<input type="checkbox"/>	8	The wiring terminals have been insulated.
Environment and mechanical conditions		
<input type="checkbox"/>	1	No foreign objects, such as wire end or metal powder, which may cause short circuit of the signal wire and power cables, exist inside and outside of the servo drive.
<input type="checkbox"/>	2	The servo drive or external regenerative resistor is not placed on flammable objects.
<input type="checkbox"/>	3	Installation and shaft and mechanical connection are reliable.
<input type="checkbox"/>	4	The servo motor and connected machine are in conditions ready for running.

5

5.1.2 Power Supply Connection

1) Connect the power supply of the control circuit and main circuit.

Connect the power supply of the control circuit (L1C, L2C) and main circuit.

The main circuit power terminals are L1, L2 and R, S, T respectively for the single-phase 220 V and three-phase 220/380 V models.

- After connecting the power supply of the control circuit and main circuit, if the bus voltage indicator is in normal display and the keypad displays "Reset", "Nrd", and "Rdy" in sequence, it indicates that the servo drive is ready for running and waiting for the S-ON signal from the host controller.
- If the keypad always displays "Nrd", rectify the fault according to the instructions in Chapter 8.
- If the keypad displays the fault code, rectify the fault according to the instructions in Chapter 8.

2) Turn off the S-ON signal.

Set a DI terminal of the servo drive with function 1 (FunIN.1:S-ON, servo ON) and set the terminal

logic, and then set this DI to inactive via communication with the host controller or external switch.

Relevant function No.:

No.	Function Symbol	Function Name	Description
FunIN.1	S-ON	Servo ON	Invalid: Servo motor disabled Valid: Servo motor enabled

5.1.3 Jogging

Perform jogging to check whether the motor can rotate properly without abnormal vibration or noise. This operation can be performed via the keypad, two external DIs, or Inovance servo commissioning software (InoServoShop). The motor jogs at the speed set in H06-04.

1) Jogging via the keypad

Switch to H0D-11 on the keypad to enter the jogging mode, and the keypad displays the default jogging speed in H06-04.

Press key UP/DOWN to set the jogging speed, and press key SET to enter the jogging state. The keypad displays "JOG". Then, press key UP/DOWN to perform forward or reverse jogging. After you press key MODE to exit the jogging mode, H06-04 is restored to the default value without storing the setting. For the operation and display, refer to section 4.5.1.

Relevant parameters:

Function Code	Parameter Name	Setting Range	Unit	Function	Property	Effective Time	Default
H06-04	Jog speed setting value	0 to 6000	RPM	Set the jogging speed value.	During running	Immediate	100

2) Jogging via DI

Note	Jogging via DI is permitted in any mode.
-------------	--

Set two external DI terminals respectively with functions FunIN.18 and FunIN.19. After setting the jogging speed in H06-04, turn on the S-ON signal to perform jogging via DI.

Relevant function No.:

No.	Function Symbol	Function Name	Description
FunIN.18	JOGCMD+	Forward jog	Valid: Reference input Invalid: Reference input stopped
FunIN.19	JOGCMD-	Reverse jog	Valid: Input reverse to reference direction Invalid: Reference input stopped

3) Jogging via Inovance servo commissioning software

Enter the jogging interface of the Inovance servo commissioning software, set the jogging speed in H06-04, and click the S-ON button. Click the forward/reverse button on the interface to perform forward or reverse running. After you exit the jogging interface and the jogging mode, H06-04 is restored to the default value without storing the setting.

5.1.4 Selection of Rotating Direction

Set H02-02 to change the motor rotating direction without changing the polarity of the input reference.

Relevant parameters:

Function Code	Parameter Name	Setting Range	Function	Property	Effective Time	Default
H02-02	Rotating direction selection	0: CCW direction as the forward direction 1: CW direction as the forward direction	Set the motor forward direction viewed from the motor shaft.	At stop	Power-on again	0

The change of H02-02 setting does not affect the output pulse format and positive/negative attribute of monitored parameters of the servo drive.





"Forward drive" in the limit switch function has the same direction set in H02-02.

5.1.5 Selection of Output Pulse Phase

The output of the servo drive is phase A + phase B quadrature pulse.

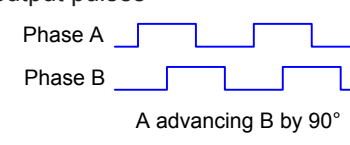
The phase relationship between phase A and phase B pulses can be changed by setting H02-03 without changing the motor rotating direction.

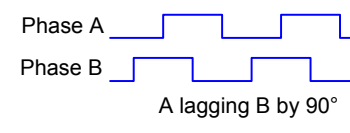
Relevant parameters:

Function Code	Parameter Name	Setting Range	Function	Property	Effective Time	Default
H02-03	Output pulse phase	0: Phase A advancing phase B 1: Phase A lagging phase B	Set the phase relationship of output pulses  Phase A  Phase B  A advancing B by 90°	At stop	Power-on again	0
			 Phase A  Phase B  A lagging B by 90°			

5

5.1.6 Brake Setting

For detailed hardware descriptions of the brake, refer to section 3.4.5.

a. Brake software setting

For the servo motor with brake, set a DO terminal of the servo drive with function 9 (FunOUT.9: BK, brake output), and set the terminal logic.

Relevant function No.:

No.	Function Symbol	Function Name	Description
FunOUT.9	BK	Brake output	Invalid: The power is on, the brake is applied, and the motor is in position lock state. Valid: The power is off, the brake is released, and the motor can rotate.

The operating time sequences of the brake are different between normal state and faulty state of the servo drive.

b. Brake time sequence in normal state of servo drive

The brake time sequence in normal state of the servo drive includes two conditions: motor static and motor rotating

Static: The actual motor speed is smaller than 20 RPM.

Rotating: The actual motor speed is equal to or larger than 20 RPM.

■ Brake time sequence at motor static

If the S-ON signal becomes OFF, and the current motor speed is smaller than 20 RPM, the servo drive acts according to the brake time sequence for motor static state.



After the brake output signal changes from OFF to ON, do not input a position/speed/torque reference within the time of H02-09. Otherwise, reference loss or running error may occur.

When the motor drives the vertical axis, the load may move slightly due to the gravity or external force. At motor static, if the S-ON signal becomes OFF, the brake output becomes OFF immediately. However, within the time of H02-10, the motor is still energized to prevent the load from moving due to the gravity or external force.

Figure 5-3 Brake time sequence at motor static

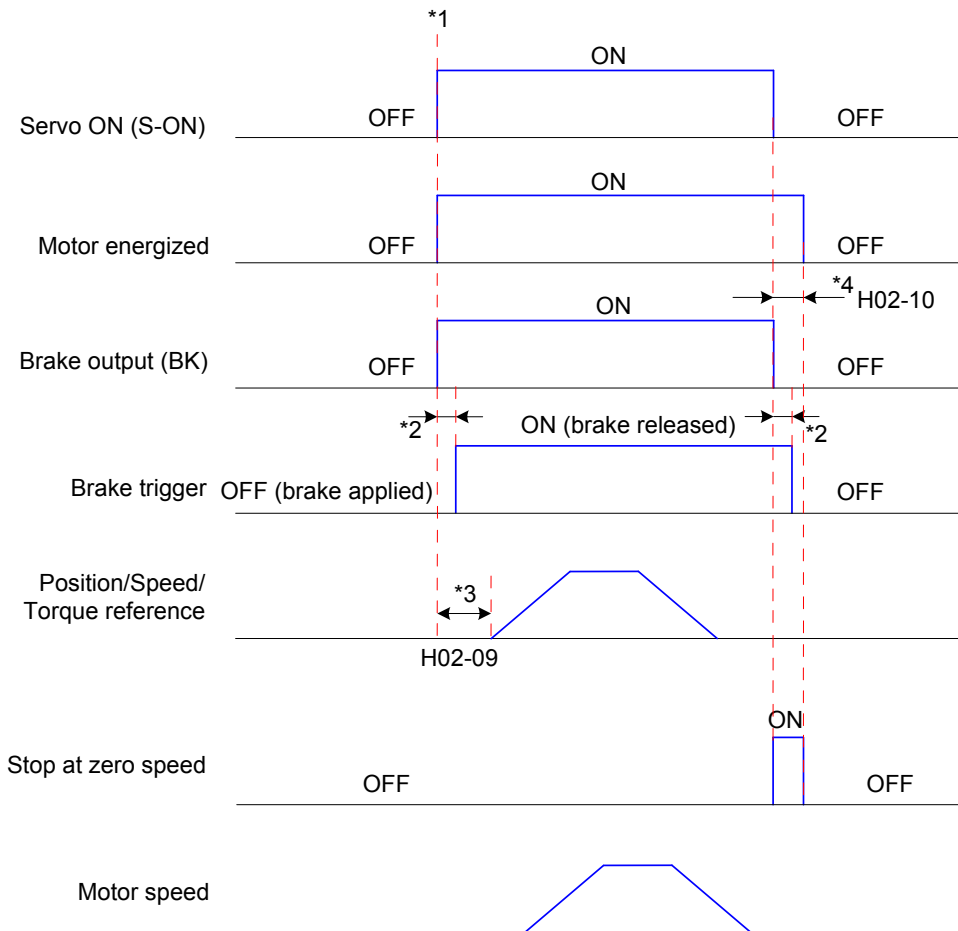

Note

- *1: When the S-ON signal is turned on, the brake output signal becomes ON, and the motor becomes energized.
- *2: For the delay time of the brake contact, see the motor specifications in Chapter 1.
- *3: The time interval from the moment when brake output becomes ON to the moment when the command is input must be larger than H02-09.
- *4: At motor static (motor speed smaller than 20 RPM), when the S-ON signal is turned off, the brake output signal becomes OFF. Set the delay for the motor to become de-energized in H02-10 after the brake output signal becomes OFF.

5

Relevant parameters:

Function Code	Parameter Name	Setting Range	Unit	Function	Property	Effective Time	Default
H02-09	Delay from brake output ON to command received	0 to 500	ms	Set the delay time from the moment when the brake output signal becomes ON to the moment when the servo drive receives the command. If the brake output function (BK) is not used, H02-09 is invalid.	During running	Immediate	250

Function Code	Parameter Name	Setting Range	Unit	Function	Property	Effective Time	Default
H02-10	Delay from brake output OFF to motor de-energized in static state	1 to 1000	ms	Set the delay from the moment when the brake output signal (BK) becomes OFF to the moment when the motor enters the de-energized state at motor static. If the brake output function (BK) is not used, H02-10 is invalid.	During running	Immediate	150

■ Brake time sequence at motor rotating

If the S-ON signal becomes OFF, and the current motor speed is equal to or larger than 20 RPM, the servo drive acts according to the brake time sequence for motor rotating state.



After the S-ON signal changes from OFF to ON, do not input a position/speed/torque reference within the time in H02-09. Otherwise, reference loss or running error may occur.

If the S-ON signal becomes OFF during servo motor rotation, the motor stops at zero speed, but the brake output signal becomes OFF only after one of the following conditions is met:

- The motor has decelerated to H02-11 when H02-12 time is not reached.
- The motor speed is still higher than H02-11 though H02-12 time is reached.

After the brake output signal changes to OFF, the motor remains in energized state within 50 ms to prevent the work from moving due to the gravity or external force.

Figure 5-4 Brake time sequence at motor rotating

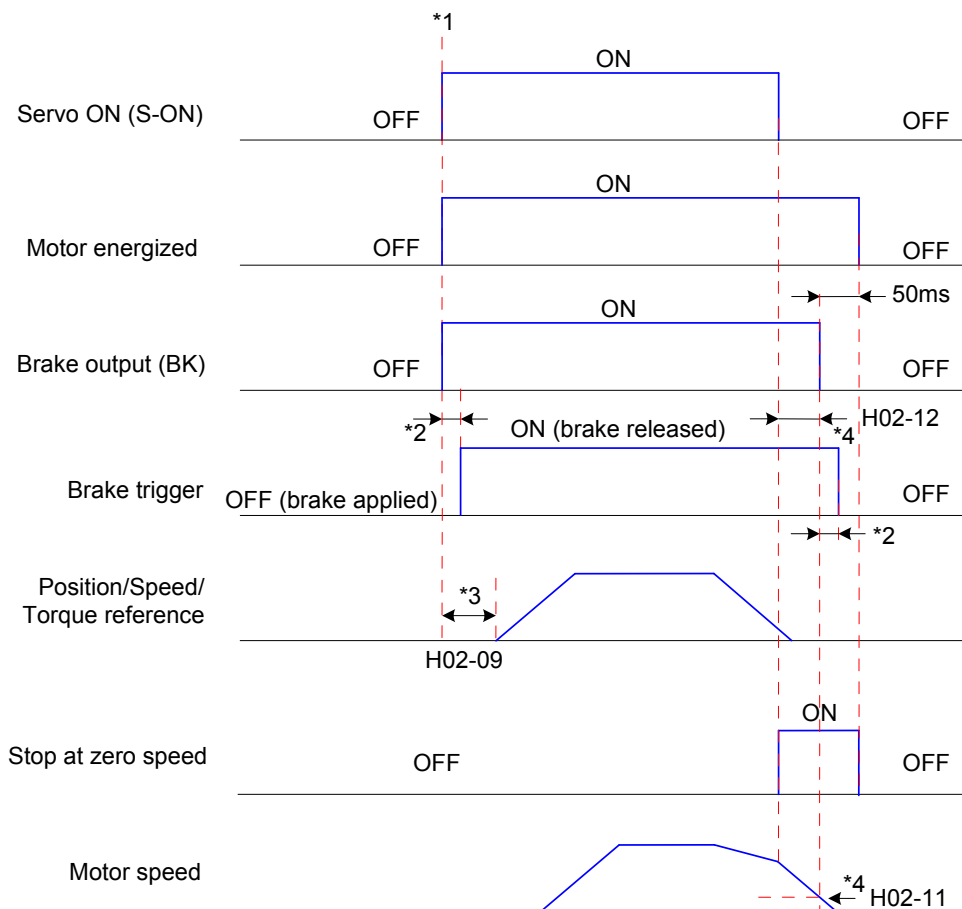



*1: When the S-ON signal is turned on, the brake output signal becomes ON, and the motor becomes energized.

*2: For the delay time of the brake contact, see the motor specifications in Chapter 1.

*3: The time interval from the moment when brake output becomes ON to the moment when the command is input must be larger than H02-09.

*4: After the brake output signal changes to OFF during motor rotation, set the delay from the moment when the S-ON signal becomes OFF to the moment when the brake output signal becomes OFF in H02-11 and H02-12. The motor enters the de-energized state after a 50 ms delay after the brake output signal becomes OFF.

Relevant parameters:

Function Code	Parameter Name	Setting Range	Unit	Function	Property	Effective Time	Default
H02-11	Motor speed threshold at brake output OFF in rotating state	0 to 3000	RPM	Set the motor speed threshold when the brake output signal becomes OFF at motor rotating. If the brake output function (BK) is not used, H02-11 is invalid.	During running	Immediate	30
H02-12	Delay from brake output OFF to motor de-energized in rotating state	1 to 1000	ms	Set the delay from the moment when the brake output signal (BK) becomes OFF to the moment when the S-ON signal becomes OFF at motor rotating. If the brake output function (BK) is not used, H02-12 is invalid.	During running	Immediate	500

5

c. Brake time sequence in faulty state of servo drive

The servo faults are classified into class 1 faults (NO.1) and class 2 (NO.2). For details, refer to Chapter 8. The brake time sequences in faulty state of servo drive includes two conditions:

For NO. 1 faults:

The brake output signal becomes OFF when one of the following conditions is met (same as the brake time sequence at motor rotating in normal state of servo drive):

- The motor has decelerated to H02-11 when the H02-12 time is not reached.
- The motor speed is still higher than H02-11 though H02-12 time is reached.

For NO. 2 faults:

When a NO. 2 fault occurs and the brake is applied, the stop mode is forced to "Stop at zero speed, keeping de-energized state".

The servo motor stops at zero speed first. When the motor speed is smaller than 20 RPM, the brake output signal immediately becomes OFF once the preceding condition is met; but the motor is still in energized state within the time of H02-10.

5.1.7 Braking Setting

When the motor torque direction is opposite to the speed direction, the energy is transmitted from the motor back to the servo drive, causing rise of the bus voltage. When the bus voltage rises to the braking threshold, the energy is consumed by the regenerative resistor according to the braking requirements; otherwise, the servo drive will be damaged. The regenerative resistor can be built-in or external; the two must not be used together. The following table lists the specifications of the regenerative resistor.

Table 5-2 Specifications of the regenerative resistor for the servo drive

Drive Model	Built-in Regenerative Resistor			Min. Permissible Resistance of External Regenerative Resistor (H02-21)
	Resistance (Ω)	Power Pr (W)	Processing Power P _a (W)	
IS600PS1R1I	-	-	-	50
IS620PS1R6I	-	-	-	50
IS620PS2R8I	-	-	-	45
IS620PS5R5I	50	50	25	40
IS620PS7R6I	25	80	40	20
IS620PS012I				15
IS620PT3R5I	100	80	40	80
IS620PT5R4I	100	80	40	60
IS620PT8R4I	50	80	40	45
IS620PT012I				35
IS620PT017I	40	100	50	25
IS620PT021I				
IS620PT026I				

Note	The models S1R6 and S2R8 do not have the built-in regenerative resistor. Users need to prepare an external one themselves.
-------------	--

1) External load torque not existing

The energy at braking of reciprocating motor movement is converted into electric energy and fed back to the bus capacitor. When the bus voltage exceeds the braking voltage threshold, the regenerative resistor consumes the excessive feedback energy.

The following figure takes motor no-load running from 3000 RPM to static as an example to show the motor speed curve and energy data.

Figure 5-5 Motor speed curve example with external load torque not existing

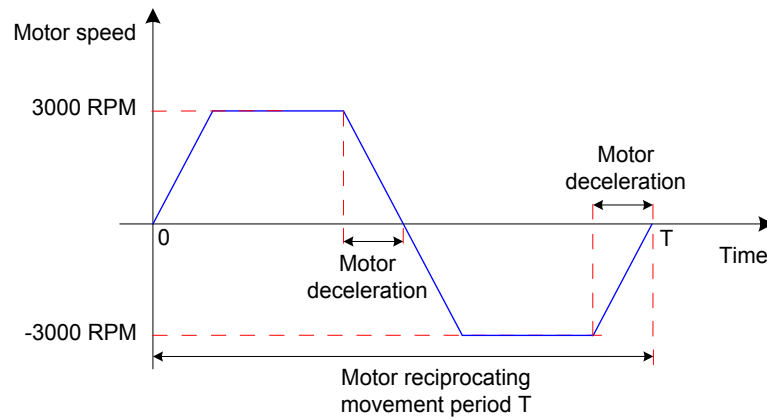

a. Energy calculation

The following two tables respectively list the energy data when the motors of 220 V and 380 V decelerate from 3000 RPM under no load to 0.

220 V:

Capacity (W)	Servo Motor Model ISMH*_*****_*****	Rotor Inertia J (10 ⁻⁴ kgm ²)	Braking Energy EO(J) from 3000 RPM to Static with No Load	Max. Braking Energy Absorbed by Capacitor EC(J)	
100	H1 (low inertia, 40/60/80 cm flange)	10B30CB	0.048	0.237	9
200		20B30CB	0.163	0.806	9
400		40B30CB	0.25	1.237	18
750		75B30CB	1.3	6.435	26
1000	H2 (low inertia, 100/130 cm flange)	10C30CB	3.12	15.44	26
1500		15C30CB	3.71	18.364	47
850	H3 (medium inertia, 130/180 cm flange)	85B15CB	15.5	76.725	26
1300		13C15CB	21.8	107.91	47
400	H4 (low inertia, 60/80 cm flange)	40B30CB	0.667	3.301	18
750		75B30CB	2.033	10.063	26

380 V:

Capacity (W)	Servo Motor Model ISMH*-*****_****	Rotor Inertia J (10^{-4} kgm ²)	Braking Energy EO(J) from 3000 RPM to Static with No Load	Max. Braking Energy Absorbed by Capacitor EC(J)	
1000	H2 (low inertia, 100/130 cm flange)	10C30CD	3.12	15.444	28
1500		15C30CD	3.71	18.3645	34
2000		20C30CD	3.06	15.147	50
2500		25C30CD	3.65	18.0675	50
3000		30C30CD	7.72	38.214	50
4000		40C30CD	12.1	59.895	81
5000		50C30CD	15.4	76.23	81
850	H3 (medium inertia, 130/180 cm flange)	85B15CD	15.5	76.725	28
1300		13C15CD	21.8	107.91	34
1800		18C15CD	28	138.6	50
2900		29C15CD	57.2	283.14	50
4400		44C15CD	90.8	449.46	81
5500		55C15CD	109.5	542.025	122
7500		75C15CD	143.1	708.345	122

If the total braking time T is known, whether an external regenerative resistor is required and the power of the resistor can be calculated based on the flowchart and formula.

b. Regenerative resistor selection

Figure 5-6 Regenerative resistor selection flowchart

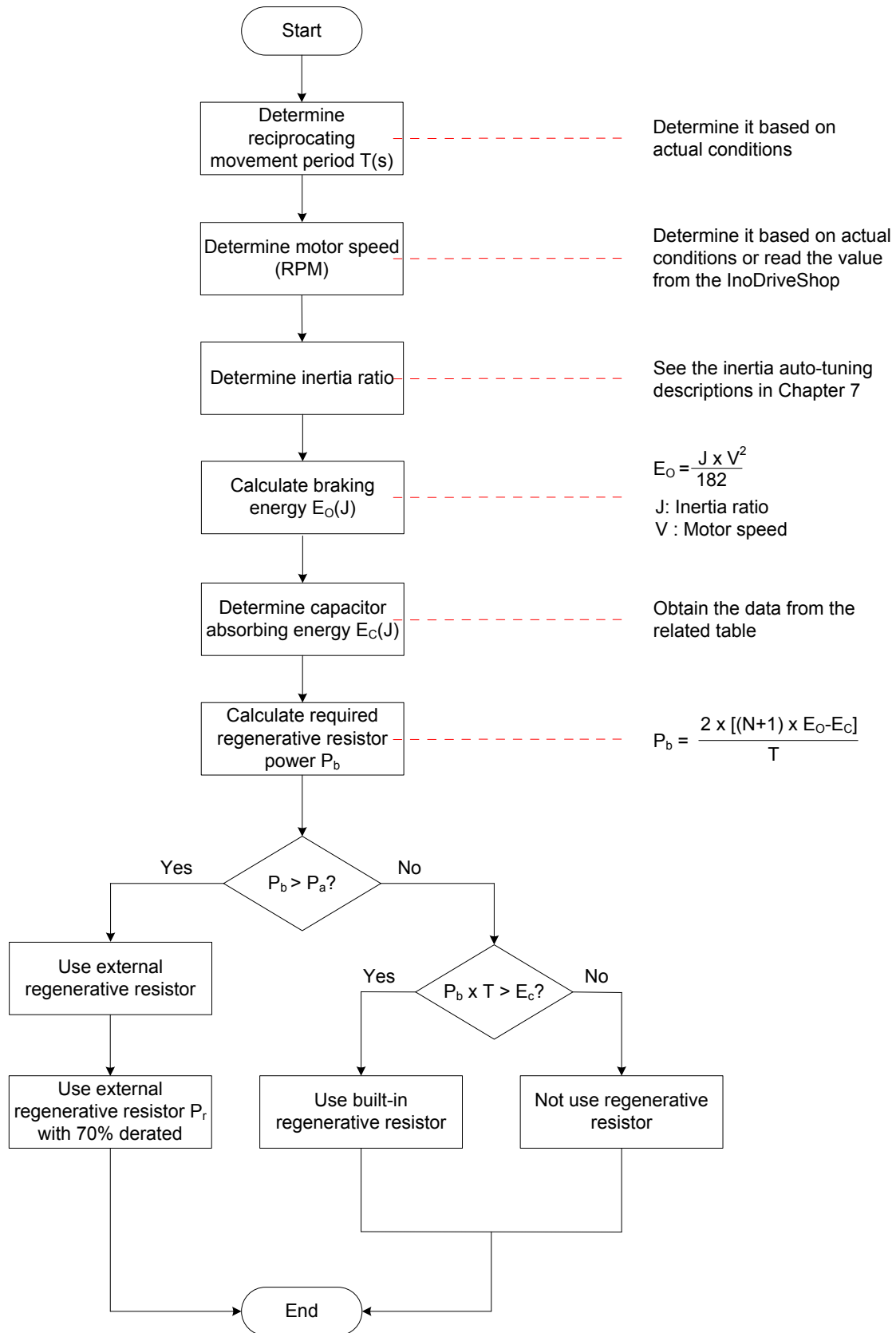

5

The following part describes the process when the motor decelerates from 3000 RPM to 0 as an example.

Assume that the load inertia is N times of the motor inertia, the braking energy is (N+1) x E_o.

when the motor decelerates from 3000 RPM to 0. The capacitor absorbs energy E_C , and the remaining energy to be consumed by the regenerative resistor is $(N+1) \times E_O - E_C$. Assume that the reciprocating movement period is T , the required regenerative resistor power is $2 \times [(N+1) \times E_O - E_C]/T$.

Determine whether to use the regenerative resistor and select the built-in or external one. Then, set H02-25 accordingly.

The resistor with aluminum case is recommended.

Relevant parameters:

Function Code	Parameter Name	Setting Range	Function	Property	Effective Time	Default
H02-25	Regenerative resistor type	0: Built-in 1: External, natural cooling 2: External, forced air cooling 3: No resistor, using only capacitor	Set the regenerative resistor type and the mode of absorbing and releasing the braking energy.	At stop	Immediate	0

Take the H1 series 750 W model as an example. Assume that the reciprocating movement period $T = 2s$, maximum speed = 3000 RPM, inertia ratio = 4, the required regenerative resistor power is:

$$P_b = \frac{2 \times [(N+1) \times E_O - E_C]}{T} = \frac{2 \times [(4+1) \times 6.4 - 9]}{2} = 23 \text{ W}$$

The calculated value is smaller than the capacity ($P_a = 25 \text{ W}$) of the built-in regenerative resistor, and a built-in regenerative resistor is sufficient to meet the requirements.

If the inertia ratio is 10 and other conditions are the same, the required regenerative resistor power is:

$$P_b = \frac{2 \times [(N+1) \times E_O - E_C]}{T} = \frac{2 \times [(10+1) \times 6.4 - 9]}{2} = 61$$

The calculated value is larger than the capacity ($P_a = 25 \text{ W}$) of the built-in regenerative resistor, and an external regenerative resistor is required. The recommended power is $E_O/(1 - 70\%) = 204.6 \text{ W}$.

c. Connection and setting of regenerative resistor

- Using external regenerative resistor:

When $P_b > P_a$, an external regenerative resistor needs to be connected. Based on the cooling mode of the regenerative resistor, set H02-25 to 1 or 2.

Use the external regenerative resistor with 70% derated, that is, $P_r = P_b/(1 - 70\%)$, and ensure the power is larger than the permissible minimum resistance of the servo drive.

Remove the jumper between P_{\oplus} and D, and connect two ends of the resistor respectively to terminals P_{\oplus} and C.

Figure 5-7 Connection diagram of external regenerative resistor

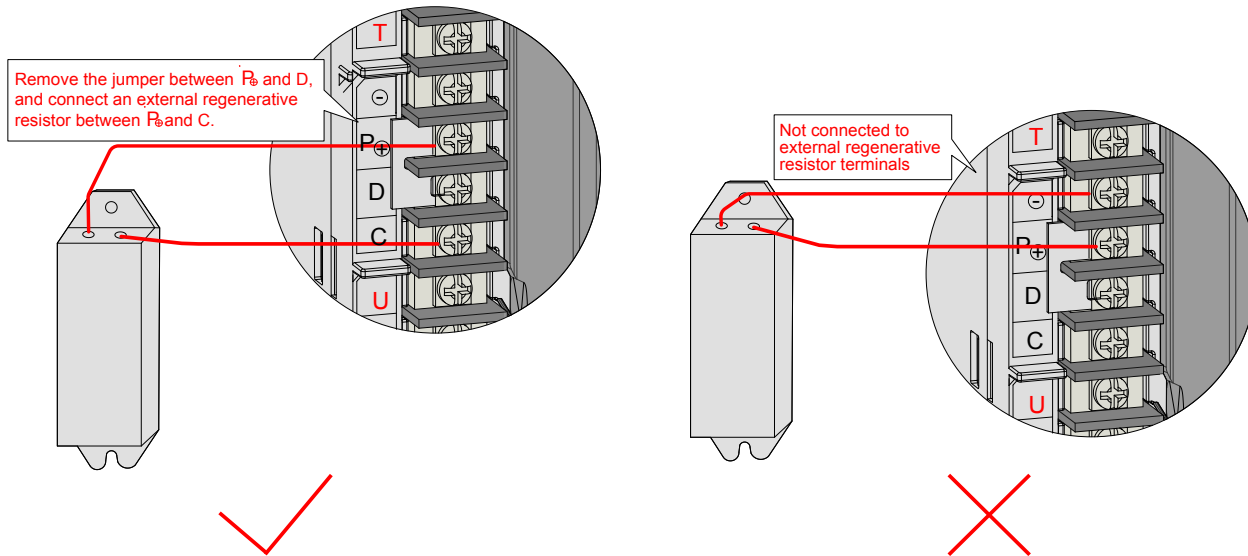

For the wire size, refer to Chapter 3.

Based on the cooling mode of the regenerative resistor, set H02-25 to 1 or 2, and set the following parameters.

Relevant parameters:

Function Code	Parameter Name	Setting Range	Unit	Function	Property	Effective Time	Default
H02-21	Permissible minimum resistance of regenerative resistor	Model dependent	-	Display the permissible minimum resistance of the external regenerative resistor.	At display	-	Model dependent
H02-26	Power of external regenerative resistor	1 to 65535	W	Set the power of the actually used external regenerative resistor. Note: The power of the actually used external regenerative resistor must not be smaller than the calculated value.	At stop	Immediate	Model dependent
H02-27	Resistance of external regenerative resistor	1 to 1000	Ω	Set the resistance of the actually used external regenerative resistor. Note: The resistance of the actually used external regenerative resistor must not be smaller than the permissible minimum resistance of regenerative resistor in H02-21. Otherwise, fault Err.922 will occur.	At stop	Immediate	Model dependent

**CAUTION**

Set the power and resistance of the external regenerative resistor in H02-26 and H02-27 correctly.

Ensure the resistance of the external regenerative resistor is larger than the permissible minimum resistance.

In natural environment, when the regenerative resistor is used at its rated power rather than the processing power (average), the temperature of the resistor will rise to above 120°C under continuous braking. To ensure safety, reduce the temperature with force air cooling, or use a resistor with a thermal switch. For the load characteristics of the regenerative resistor, consult the manufacturer.

Set the heat dissipation coefficient based on the heat dissipation condition of the external regenerative resistor.

Relevant parameters:

Function Code	Parameter Name	Setting Range	Unit	Function	Property	Effective Time	Default
H02-24	Resistor heat dissipation coefficient	10 to 100	%	Set the heat dissipation coefficient for the external regenerative resistor. The value is not larger than 30% when natural cooling is used. The value is not larger than 50% when forced air cooling is used.	At stop	Immediate	30

Note

A larger resistor heat dissipation coefficient means better braking efficiency.

- Using built-in regenerative resistor:

When $P_b < P_a$ and $P_b \times T > EC$, the built-in regenerative resistor is used. Set H02-25 to 0.

When using the built-in regenerative resistor, connect terminals P_b and D with a jumper.

Figure 5-8 Connection of the built-in regenerative resistor

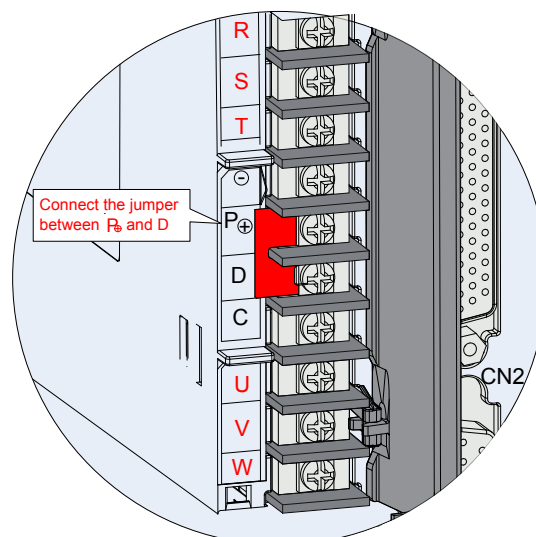

Check that the following parameters are set according to section 1.1.4.

Relevant parameters:

Function Code	Parameter Name	Setting Range	Function	Property	Effective Time	Default
H02-22	Power of built-in regenerative resistor	Model dependent	Display the power of the built-in regenerative resistor.	At display	-	Model dependent
H02-23	Resistance of built-in regenerative resistor	Model dependent	Display the resistance of the built-in regenerative resistor.	At display	-	Model dependent

■ Not using regenerative resistor:

When $P_b \times T < EC$, no regenerative resistor is required, as the bus capacitor is sufficient to absorb the braking energy. In this case, set H02-25 to 3.

2) External load torque existing, making the motor in generating state

When the motor torque direction is the same as the rotating direction, the motor produces energy externally. In some special applications where the motor torque direction is opposite to the rotating direction, the motor is in generating state, and pumps the electric energy back to the servo drive.

When the load is in continuous generating state, the common DC bus is recommended.

Figure 5-9 Example of curve for external load torque existing

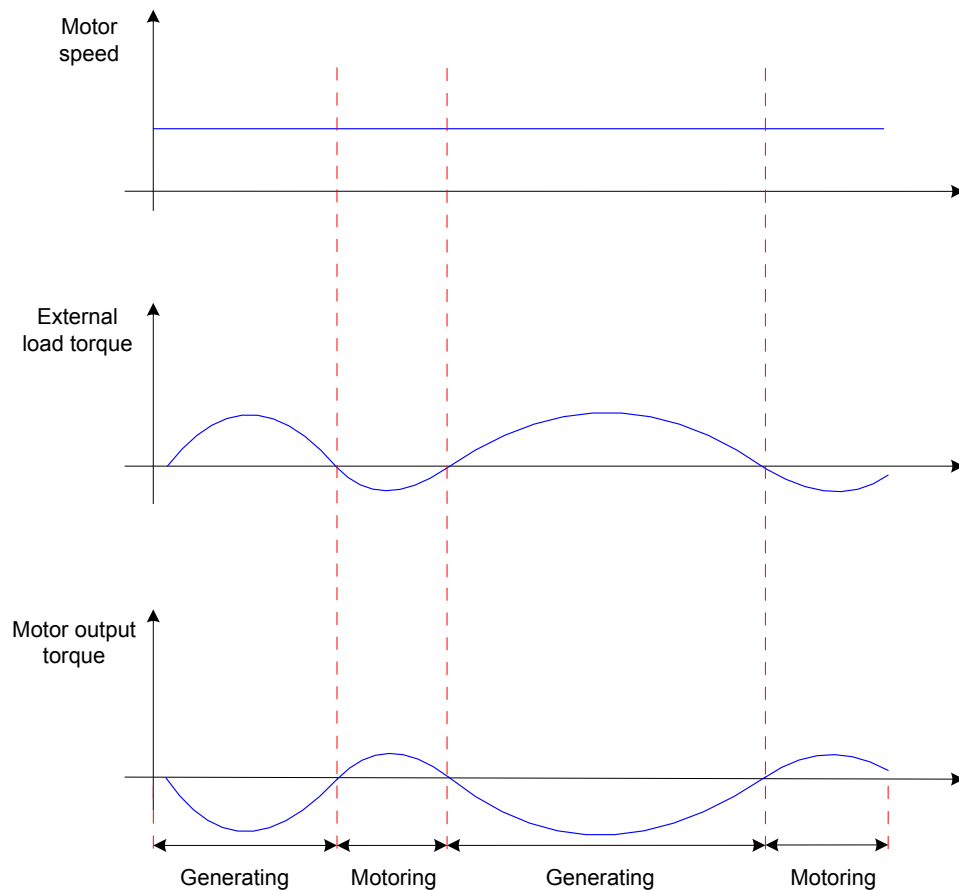

Take the H1 series 750 W model (rated torque 2.39 Nm) as an example. When the external load torque is 60% of the rated torque and the motor speed is 1500 RPM, the power pumped back to the drive is:

$$(60\% \times 2.39) \times (1500 \times 2\pi/60) = 225 \text{ W}$$

As the regenerative resistor is derated by 70%, and therefore, the power of the external regenerative resistor is:

$$225/(1 - 70\%) = 750 \text{ W, with resistance } 50 \Omega$$

5.1.8 Servo Running

1) Turn on the S-ON signal.

When the servo drive is ready for running, the keypad displays "Run"; but if there is no reference input, the servo motor is in locked state.

2) After a reference is input, the servo motor starts to rotate.

Table 5-3 Servo running operations

Applicable	No.	Description
<input type="checkbox"/>	1	At first-time running, set a appropriate reference to make the motor run at low speed and check the motor rotation is correct.
<input type="checkbox"/>	2	Observe whether the motor rotating direction is correct. If the motor rotating direction is opposite to the expected direction, check the input reference and reference direction.
<input type="checkbox"/>	3	If the motor rotating direction is correct, view the actual speed in H0B-00 and average load ratio in H0B-12 on the keypad or Inovance servo commissioning software.
<input type="checkbox"/>	4	After checking the preceding running conditions, set relevant parameters to match the actual conditions.
<input type="checkbox"/>	5	Commission the servo drive according to the instructions in Chapter 8.

3) Power-on time sequence

Figure 5-10 Power-on time sequence

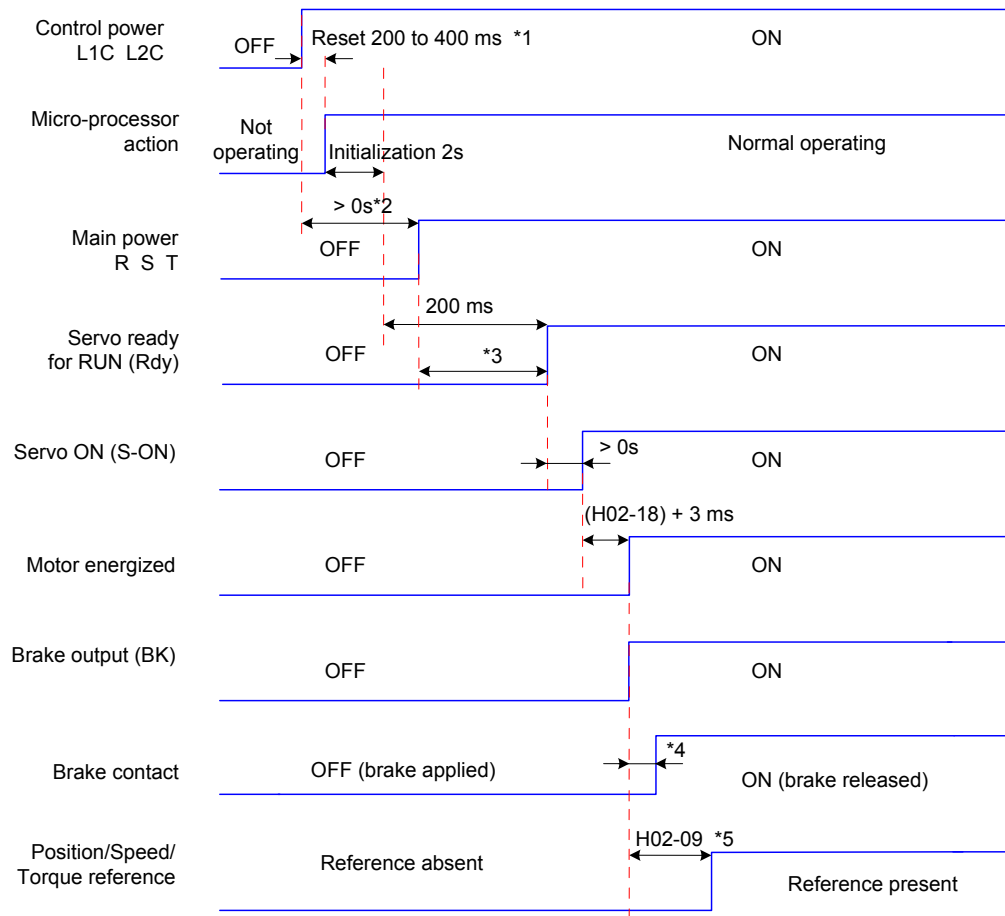

5

Note	<p>*1: The reset time is determined by the +5V power setup time of the micro-processor.</p> <p>*2: > 0s means that the time is determined by the main power connection moment.</p> <p>*3: When the control power and main power are connected at the same time, the time is the same as the time from micro-processor initialization completed to Rdy signal active.</p> <p>*4: For the brake triggering delay time, see the motor specifications in Chapter 1.</p> <p>*5: When DO function 9 (FunOUT.9:BK) is not used, H02-09 is invalid.</p>
-------------	--

4) Stop time sequence at warning or fault

a. NO. 1 fault: Coast to stop, keeping de-energized state

Figure 5-11 Time sequence of "coast to stop, keeping de-energized state" at NO. 1 fault

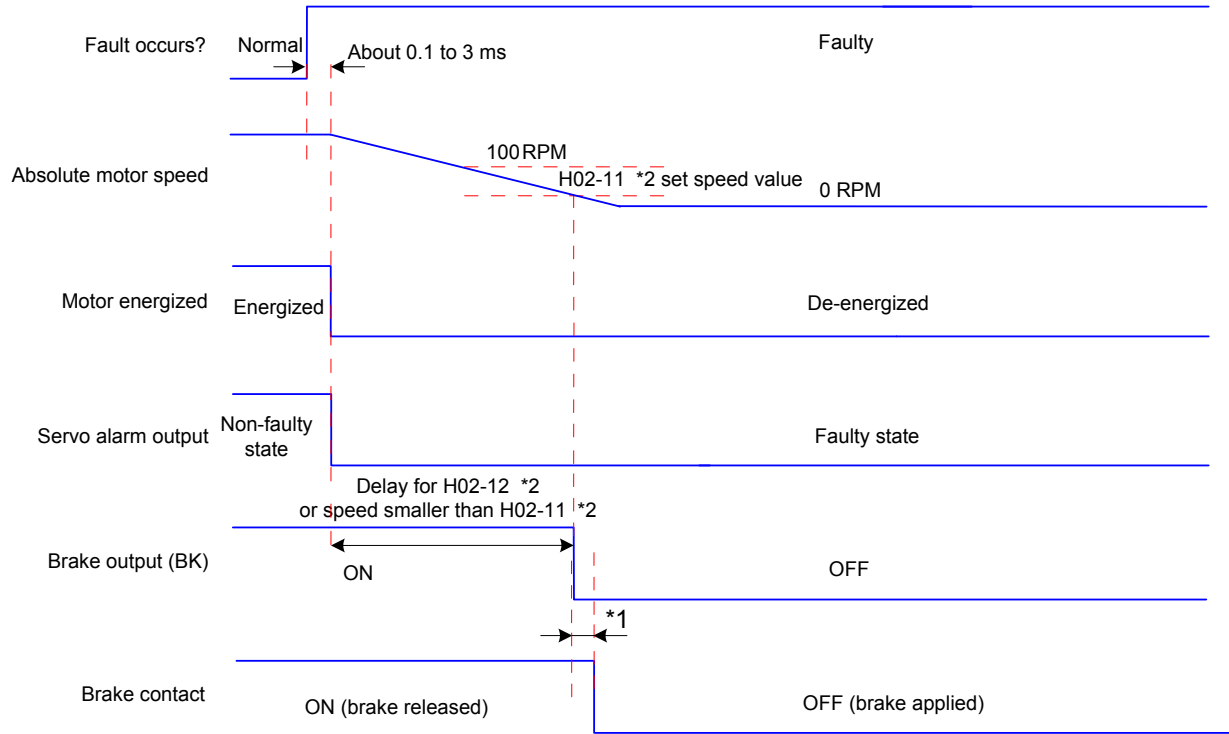

Note	<p>*1: For the brake triggering delay time, see the motor specifications in Chapter 1.</p> <p>*2: When DO function 9 (FunOUT.9:BK) is not used, H02-11 and H02-13 are invalid.</p>
-------------	--

b. NO. 2 fault (without brake): Coast to stop, keeping de-energized state

Figure 5-12 Time sequence of "coast to stop, keeping de-energized state" at NO. 2 fault

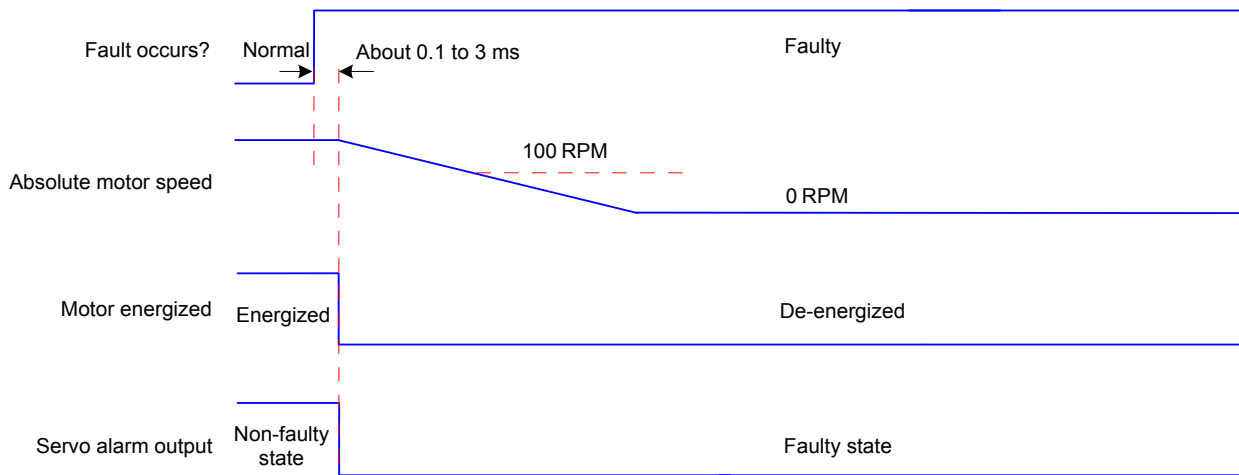

c. NO. 2 fault (without brake): Stop at zero speed, keeping de-energized state

Figure 5-13 Time sequence of "stop at zero speed, keeping de-energized state" at NO. 2 fault (without brake)

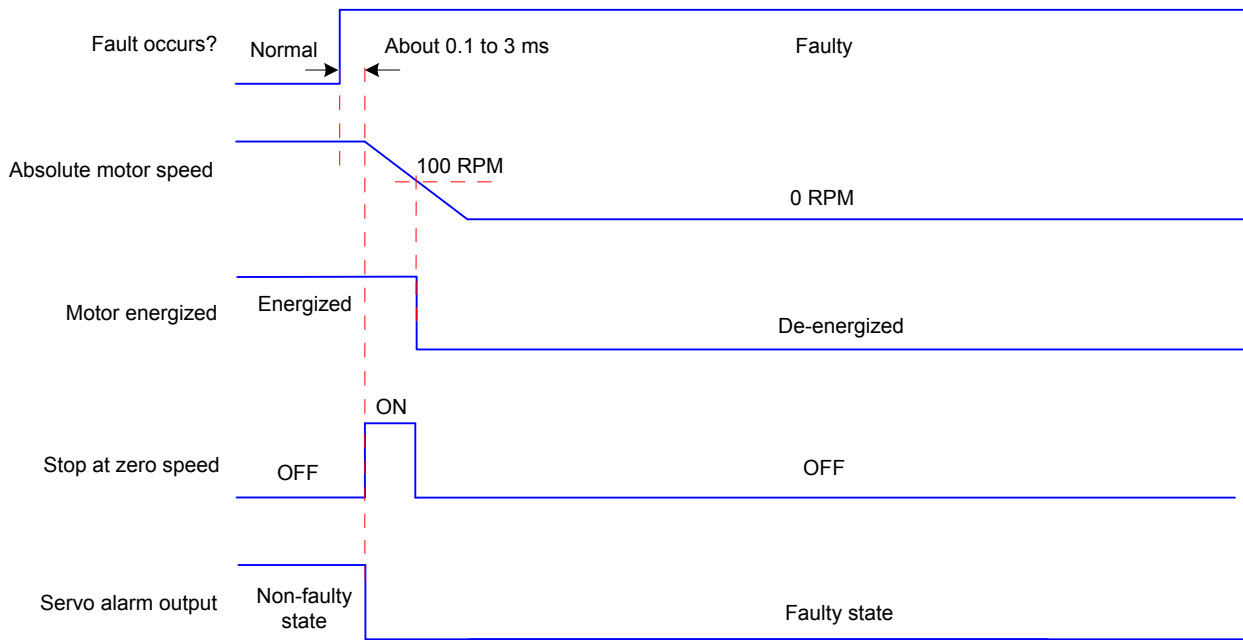

d. NO. 2 fault (with brake): Stop at zero speed, keeping de-energized state

Figure 5-14 Time sequence of "stop at zero speed, keeping de-energized state" at NO. 2 fault (with brake)

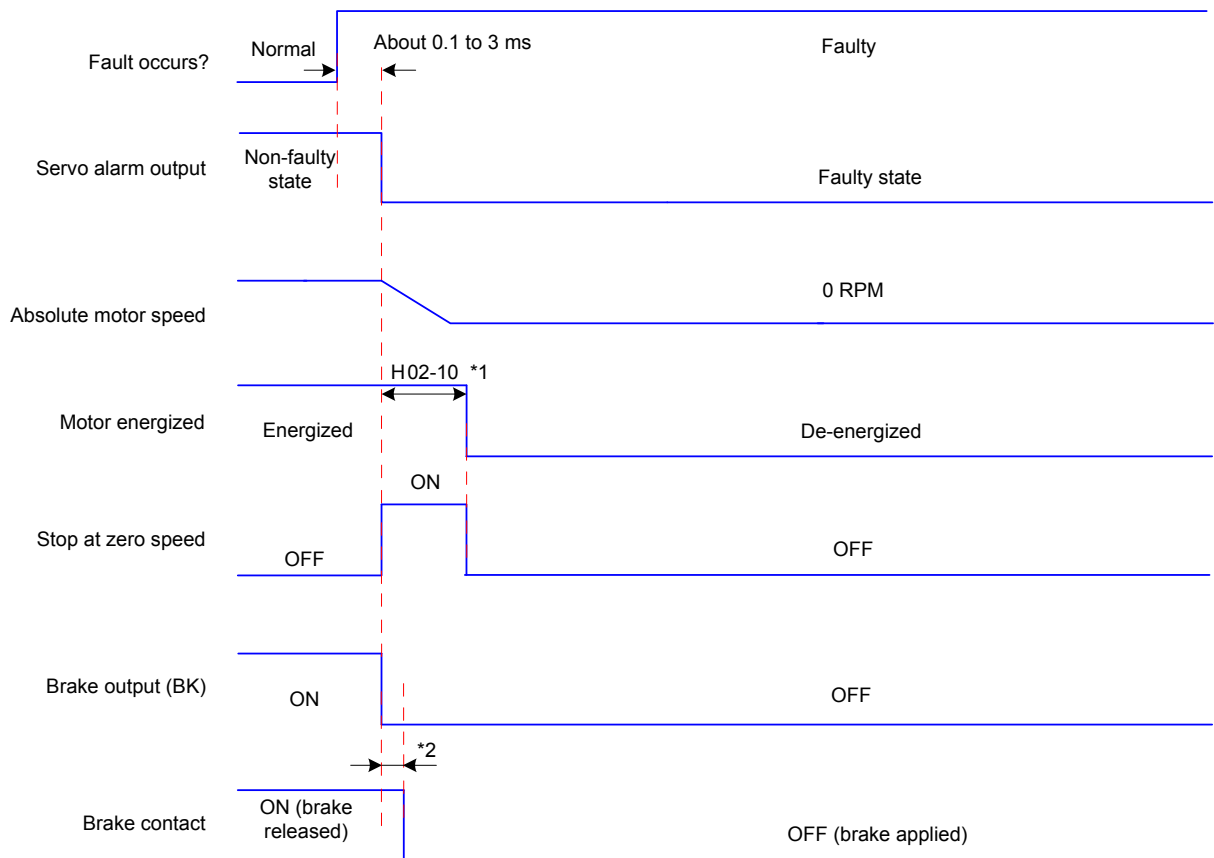

Note	<p>*1: When DO function 9 (FunOUT.9:BK) is not used, H02-10 is invalid.</p> <p>*2: For the delay time of the brake contact, see the motor specifications in Chapter 1.</p>
-------------	--

When NO.3 warnings occur in the servo drive, such as Er.900 (DI emergency braking), Er.950 (forward limit switch warning), and Er.952 (reverse limit switch warning), the servo drive stops according to the following time sequence.

e. Limit switch warning, braking stop warning: Stop at zero speed, keeping position locking state

Figure 5-15 Time sequence at warnings that cause stop

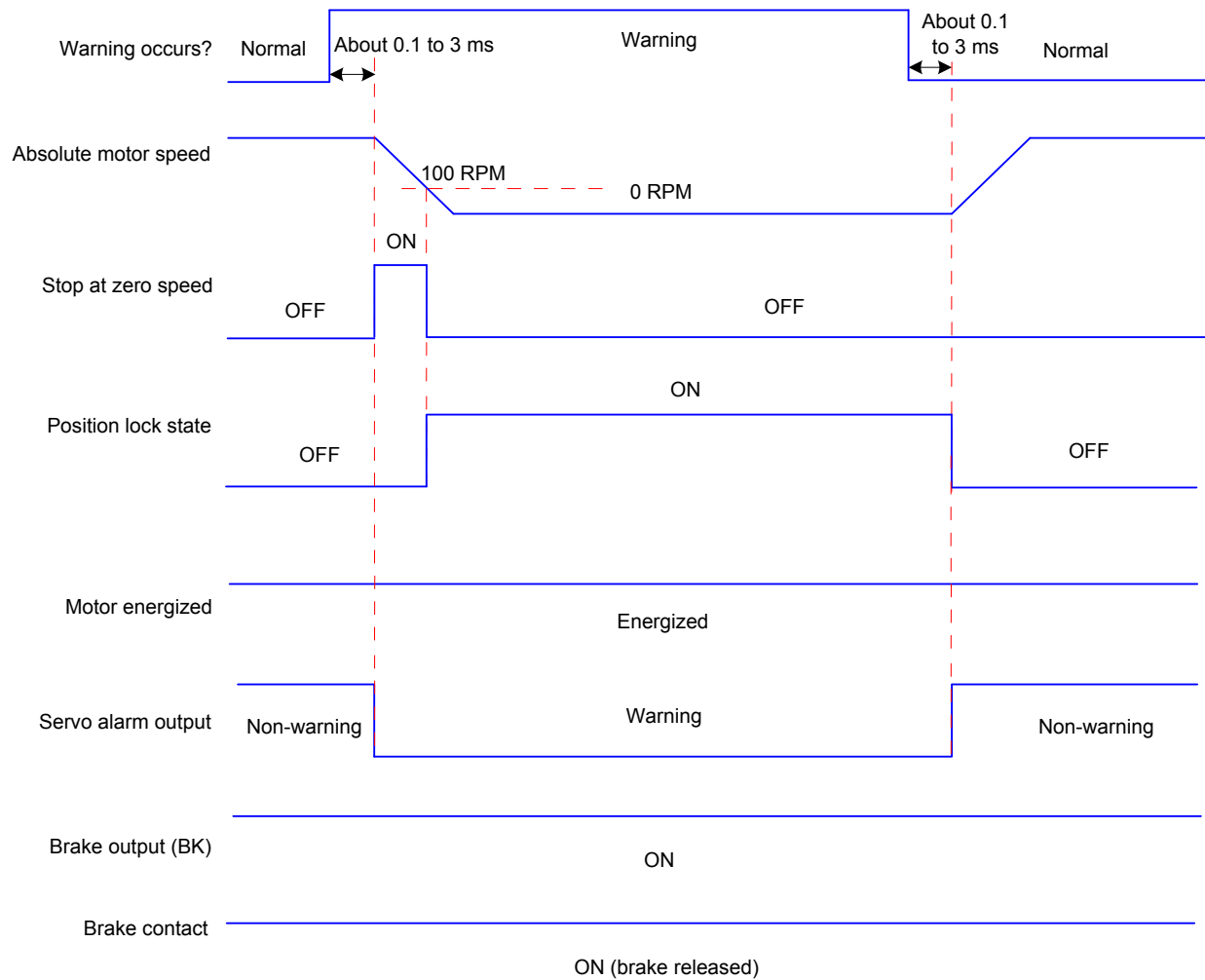

The other warnings do not affect the servo running state. The time sequence at occurrence of these warnings is as follows:

f. Warnings that do not cause stop

Figure 5-16 Time sequence at warnings that do not cause stop

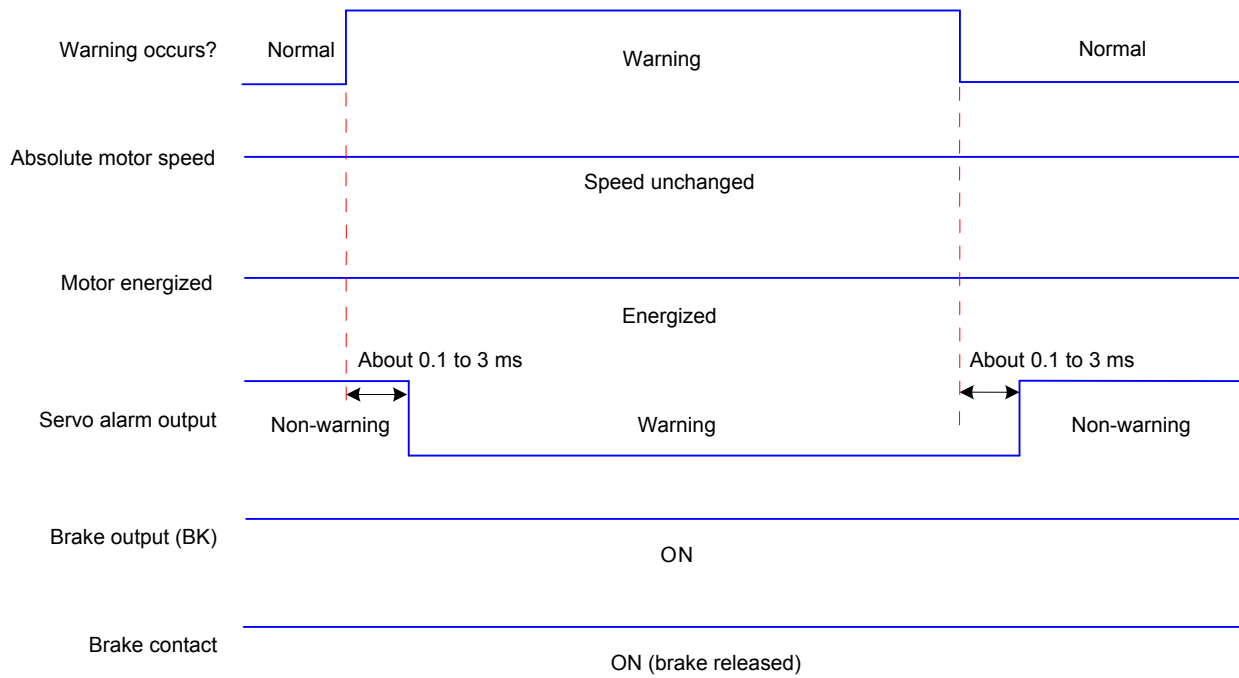

g. Fault reset

Figure 5-17 Time sequence of fault reset

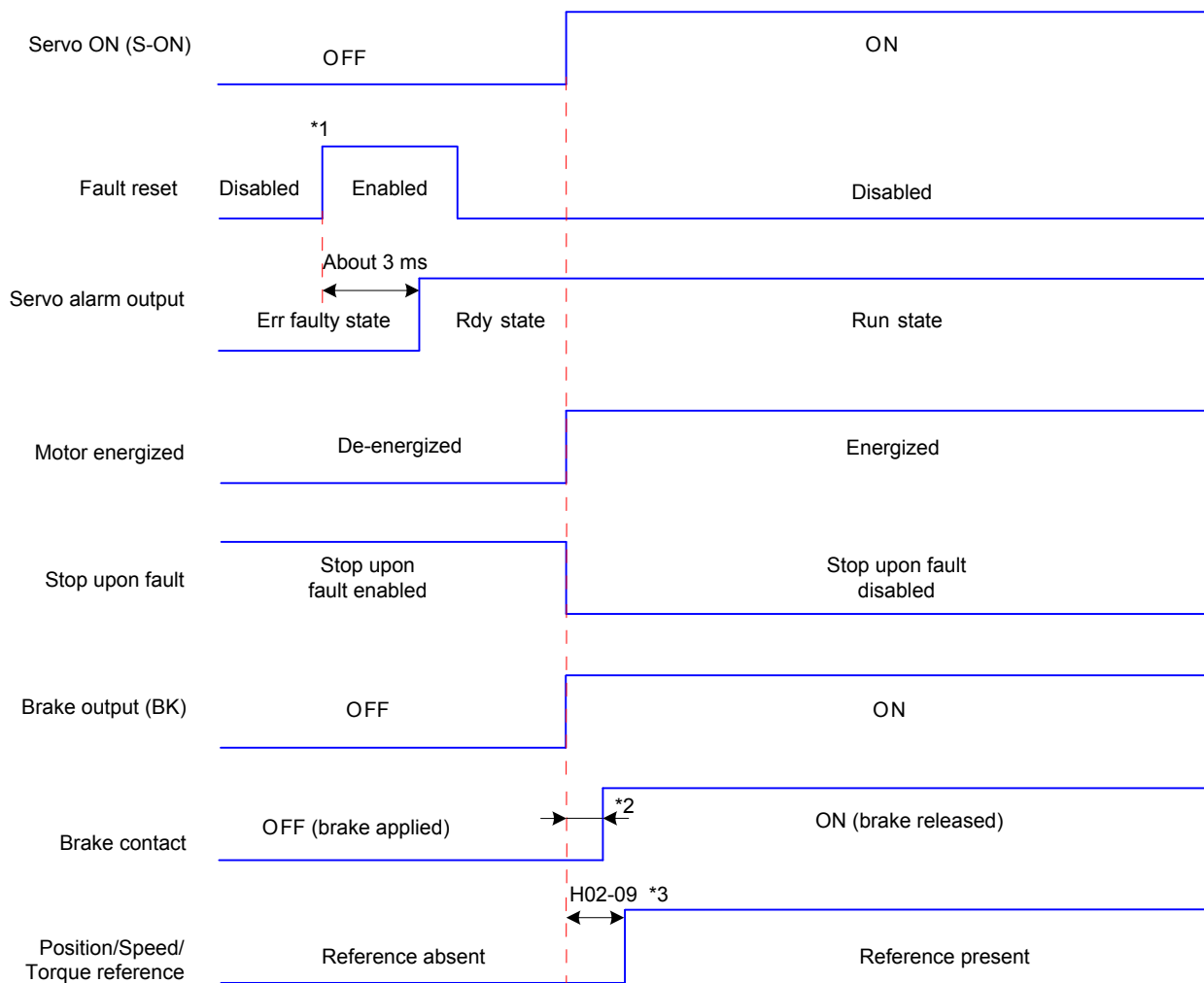

Note	<p>*1: The DI fault reset signal (FunIN.2: ALM-RST) is valid at edge change.</p> <p>*2: For the delay time of the brake contact, see the motor specifications in Chapter 1.</p> <p>*3: When DO function 9 (FunOUT.9:BK) is not used, H02-09 is invalid.</p>
-------------	---

5.1.9 Servo Stop

Servo stop includes coast to stop and zero-speed stop based on the stop mode, and de-energized state and position lock based on the stop state.

Table 5-4 Comparison of two stop modes

Stop Mode	Description
Coast to stop	<p>The servo motor is de-energized and decelerates to stop gradually. The deceleration time is affected by the friction inertia and mechanical.</p> <p>This mode features smooth deceleration and small mechanical impact, but the deceleration process is long.</p>
Stop at zero speed	<p>The servo drive outputs the reverse braking torque and the motor decelerates to 0 quickly.</p> <p>This mode features quick deceleration but a larger impact.</p>

Table 5-5 Comparison of two stop states

De-energized State	Position Lock
The motor is not energized after stopping rotation, and the motor shaft can be rotated freely.	The motor shaft is locked and cannot rotated freely after the motor stops rotation.

The servo stops due to the following causes:

- 1) Stop at S-ON signal OFF

Set a DI terminal with the S-ON function, and disable this terminal.

5

Relevant parameters:

Function Code	Parameter Name	Setting Range	Function	Property	Effective Time	Default
H02-05	Stop mode at S-ON OFF	<p>0: Coast to stop, keeping de-energized state</p> <p>1: Stop at zero speed, keeping de-energized state</p>	Set the stop mode of the servo motor when the S-ON signal is OFF.	At stop	Immediate	0

2) Stop at fault occurrence

The stop mode varies according to the fault type. For fault classification, refer to Chapter 8.

Relevant parameters:

Function Code	Parameter Name	Setting Range	Function	Property	Effective Time	Default
H02-06	Stop mode at NO.2 fault	0: Coast to stop, keeping de-energized state 1: Stop at zero speed, keeping de-energized state	Set the motor stop mode when a NO.2 fault occurs. Note: When the brake is applied, the servo drive executes the value "1" forcibly.	At stop	Immediate	0
H02-08	Stop mode at NO.1 fault	0: Coast to stop, keeping de-energized state	Set the motor stop mode when a NO.1 fault occurs.	At stop	Immediate	0

3) Stop at limit switch signal active

When the moving part moves beyond the range of safe movement, the limit switch outputs level change, and the servo drive forcibly stops the motor.

Relevant parameters:

Function Code	Parameter Name	Setting Range	Function	Property	Effective Time	Default
H02-07	Stop mode at limit switch signal active	0: Coast to stop, keeping de-energized state 1: Stop at zero speed, keeping position locking state 2: Stop at zero speed, keeping de-energized state	Set the motor stop mode when the limit switch signal is active.	At stop	Immediate	1

To prevent the work from falling when the limit switch signal is active in the vertical axis application, set H02-07 to 1. When the work moves in linear, make sure to connect the limit switch to prevent mechanical damage. If the limit switch signal becomes active, enter a reverse reference to make the motor (work) run in reverse direction.

Figure 5-18 Installation diagram of limit switch

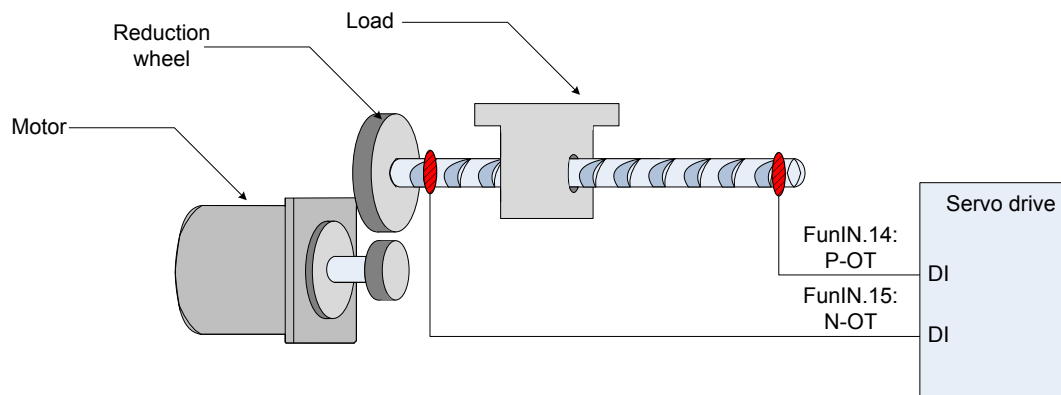

To use the limit switch function, set two DI terminals of the servo drive respectively with function 14 (FunIN.14: P-OT, forward limit switch) and function 15 (FunIN.15: N-OT, reverse limit switch) to

receive the limit switch input level signals, and set the terminal logics. The servo drive determines whether to enable or disable the limit switch function based on the DI terminal level.

Relevant function No.:

No.	Function Symbol	Function Name	Description
FunIN.14	P-OT	Forward limit switch	When the mechanical movement is outside the movable range, the servo drive implements the function of preventing the motor from sensing the limit switch. Invalid: Forward drive permitted Valid: Forward drive inhibited
FunIN.15	N-OT	Reverse limit switch	When the mechanical movement is outside the movable range, the servo drive implements the function of preventing the motor from sensing the limit switch. Invalid: Reverse drive permitted Valid: Reverse drive inhibited

4) Emergency stop

Two methods of enabling the emergency stop function are supported:

Using DI function 34 (FunIN.34: EmergencyStop)

Using the auxiliary emergency stop function in H0D-05

Relevant function No.:

No.	Function Symbol	Function Name	Description
FunIN.34	EmergencyStop	Emergency stop	Valid: Position lock after stop at zero speed, reporting warning Er.900 Invalid: Current running state unaffected

5

Function Code	Parameter Name	Setting Range	Function	Property	Effective Time	Default
H0D-05	Emergency stop	0: Keeping current running state 1: Enabled, stop mode determined in H02-05	Set whether to enable the emergency stop function. The stop mode is the same as that at S-ON signal OFF.	During running	Immediate	0

5.2 Position Control Mode

Reference unit: It means the minimum value the host controller input to the servo drive.

Encoder unit: It means that the value from the input reference processed with the electronic gear ratio.

Figure 5-19 Block diagram of the position control mode

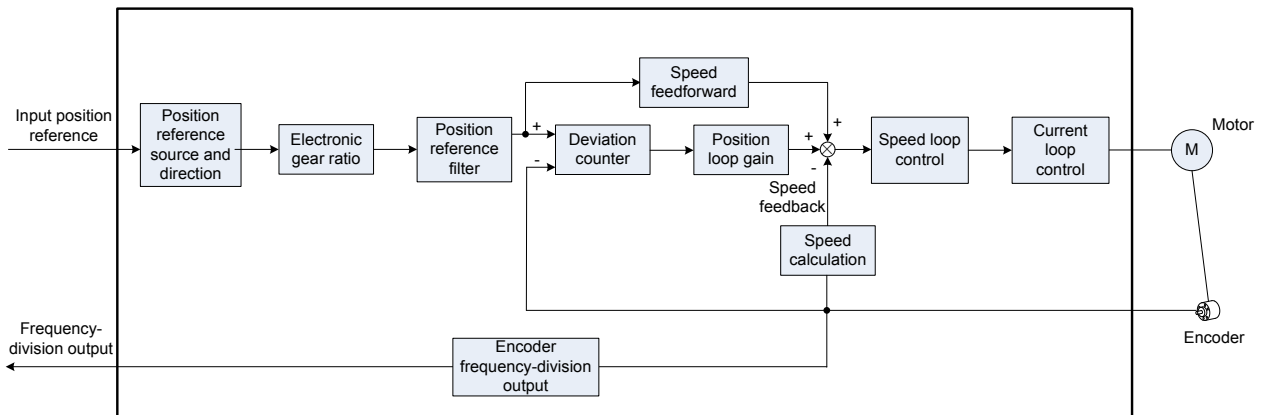

Set H02-00 to 1 on the keypad or Inovance servo commissioning software to enable the position control mode.

Set the servo drive parameters based on the mechanical structure and specifications. The following part uses the basic parameter setting to describe the position control mode.

Figure 5-20 Signal exchange between the servo drive and the host controller

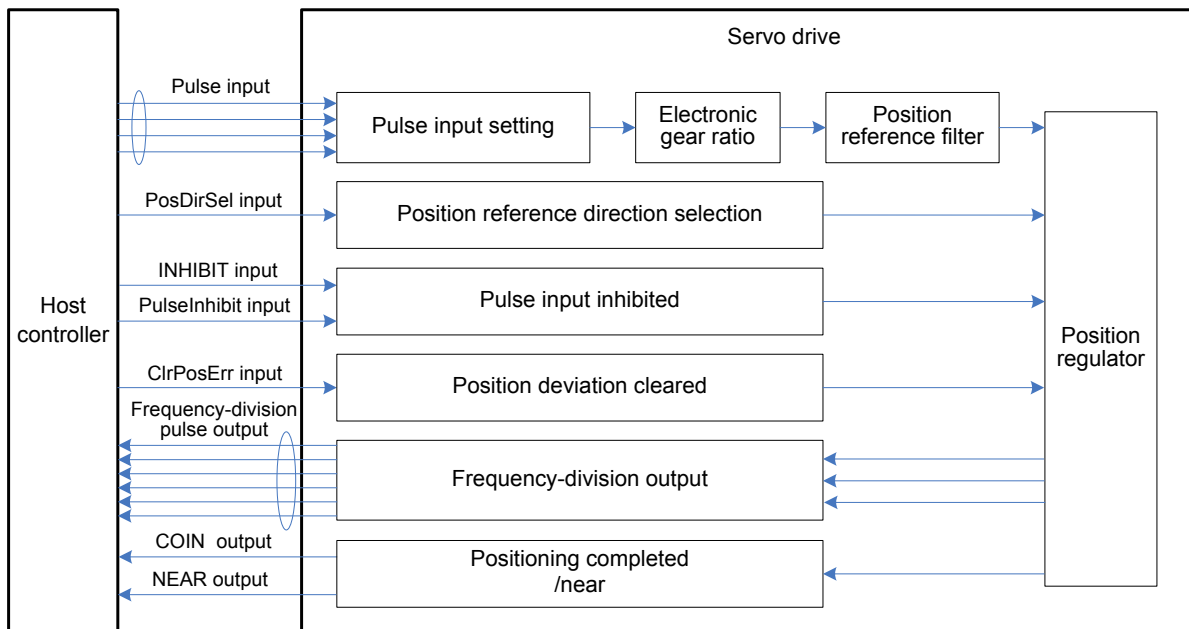

5.2.1 Position Reference Input Setting

The position reference input setting includes position reference source, direction, and inhibition.

Figure 5-21 Block diagram of position reference input setting

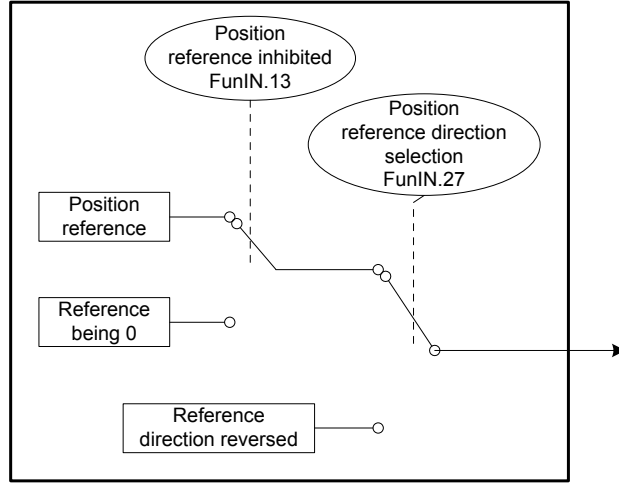

1) Position reference source

Set the position reference source in H05-00.

Figure 5-22 Setting of position reference source

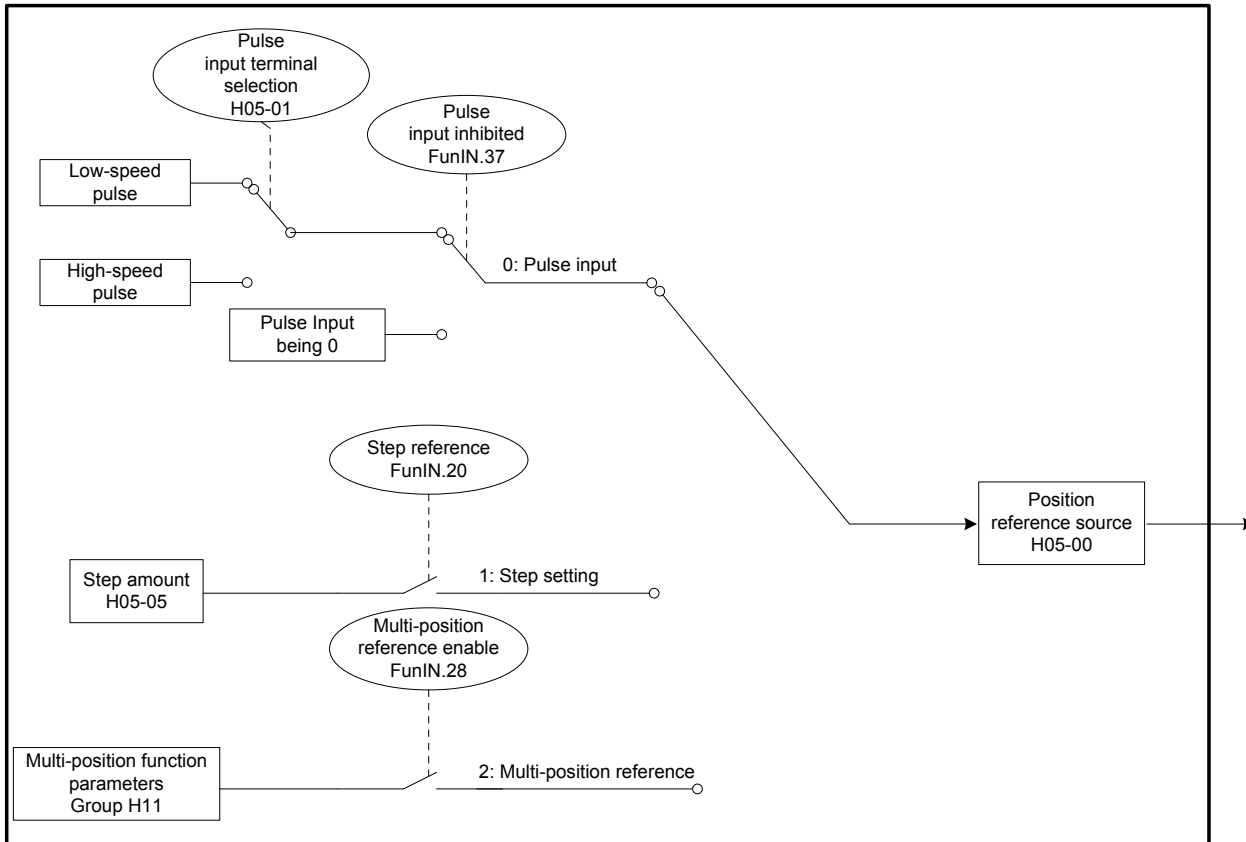

Relevant parameters:

Function Code	Parameter Name	Setting Range	Function	Property	Effective Time	Default
H05-00	Position reference source	0: Pulse input 1: Step setting 2: Multi-position reference	Set the position reference source. Pulse input is external position reference, and step reference and multi-position reference are internal ones.	At stop	Immediate	0

a. Pulse input as the source (H05-00 = 0)

Perform the following operations to obtain the correct pulse input format.

Figure 5-23 Setting flowchart of pulse input as the source

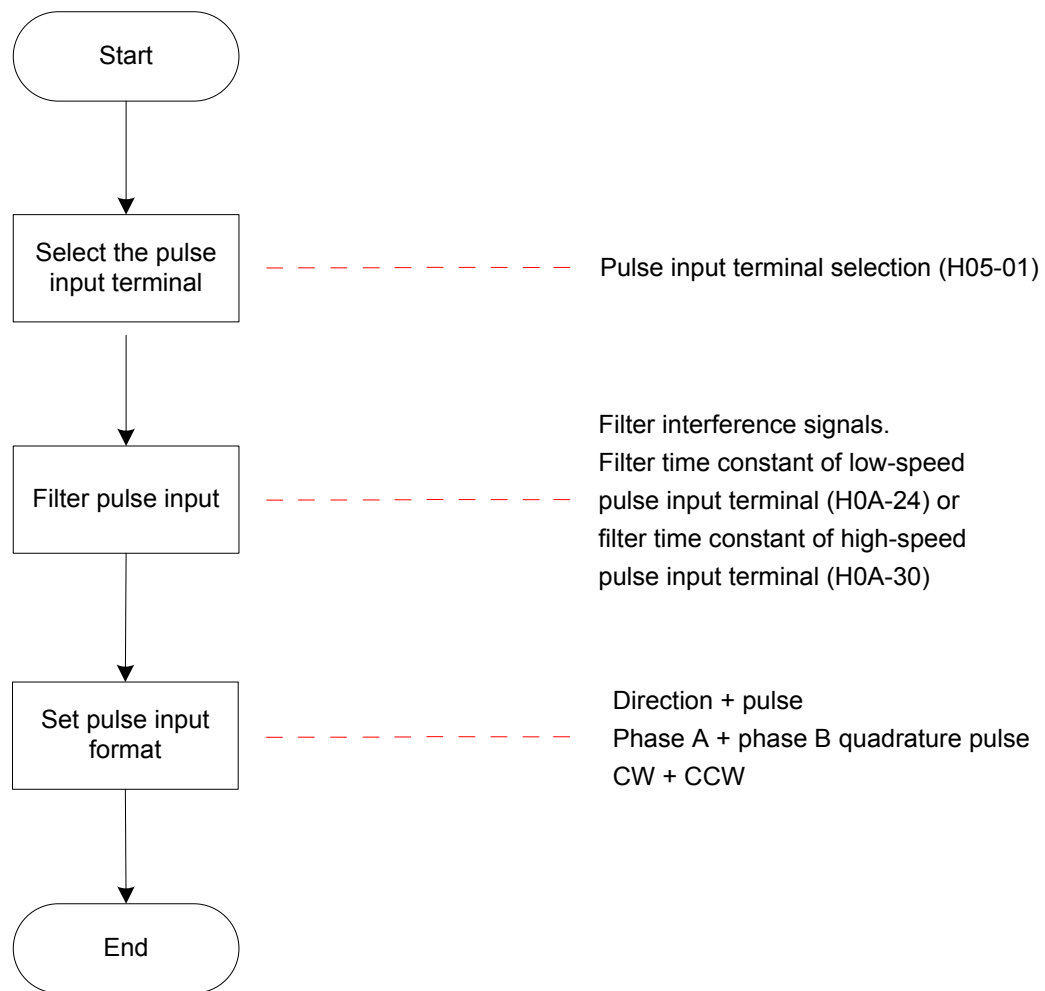

■ Pulse input terminal

The servo drive provides two pulse input terminals.

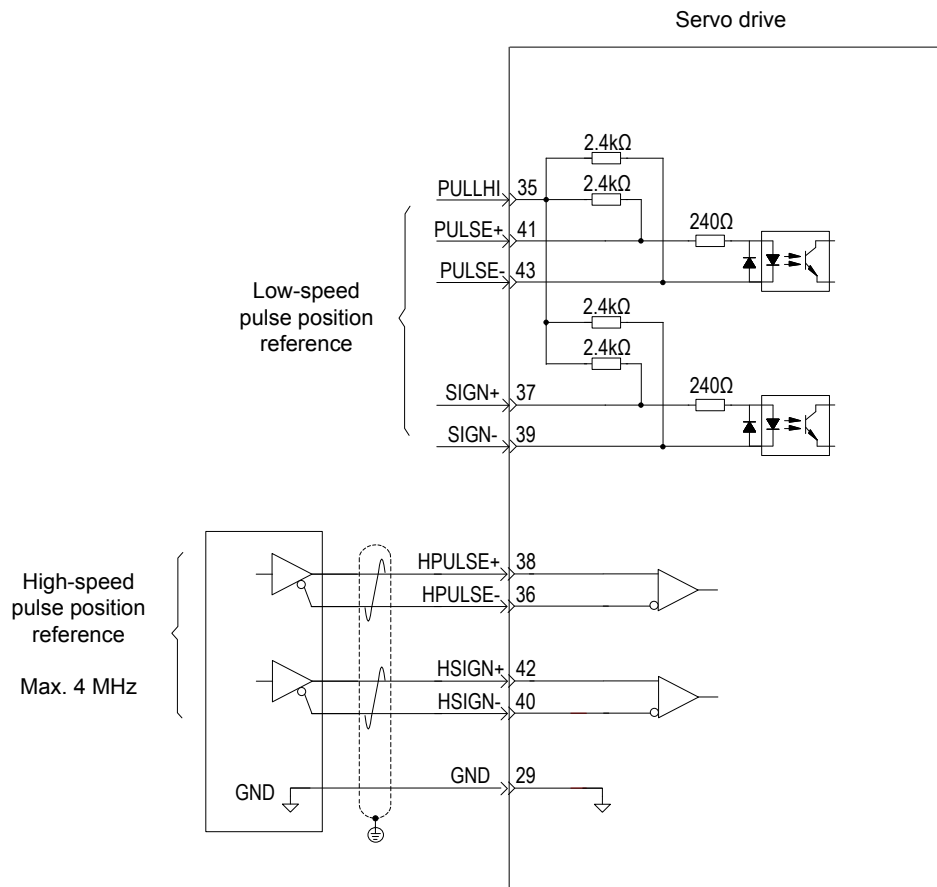

The low-speed pulse input terminal (PULSE+, PULSE-, SIGN+, SIGN-) receives differential input (maximum frequency 500 kpps) and open-collector input (maximum frequency 200 kpps).

The high-speed pulse input terminal (HPULSE+, HPULSE-, HSIGN+, HSIGN-) receives only differential input (maximum frequency 4 Mpps).

Relevant parameters:

Function Code	Parameter Name	Setting Range	Function	Property	Effective Time	Default
H05-01	Pulse input terminal selection	0: Low-speed terminals 1: High-speed terminals	Set the hardware pulse input terminal.	At stop	Immediate	0

For details on the circuit, refer to Chapter 3.

Table 5-6 Pulse input specifications

Pulse Type		Maximum Input Frequency	Voltage	Forward Current
High-speed pulse	Differential signal	4 M	5 V	< 25 mA
Low-speed pulse	Differential signal	500 k	5 V	< 15 mA
	Open-collector signal	200 k	24 V	< 15 mA

■ Pulse input terminal filter

Set the filter time to filter the pulses from the low-speed/high-speed pulse input terminals to prevent motor malfunction due to interference on the servo drive.

Relevant parameters:

Function Code	Parameter Name	Setting Range	Unit	Function	Property	Effective Time	Default
H0A-24	Filter time constant of low-speed pulse input terminal	0 to 255	25 ns	Set the filter time constant of low-speed pulse input terminal.	At stop	Power-on again	30
H0A-30	Filter time constant of high-speed pulse input terminal	0 to 255	25 ns	Set the filter time constant of high-speed pulse input terminal.	At stop	Power-on again	3

If the filter time constant is t_F , and the minimum width of input signals is t_{min} , the input signal and filtered signal are as shown in the following figure. The filtered signal has a t_F delay over the input signal.

Figure 5-24 Waveform example of signal filtering

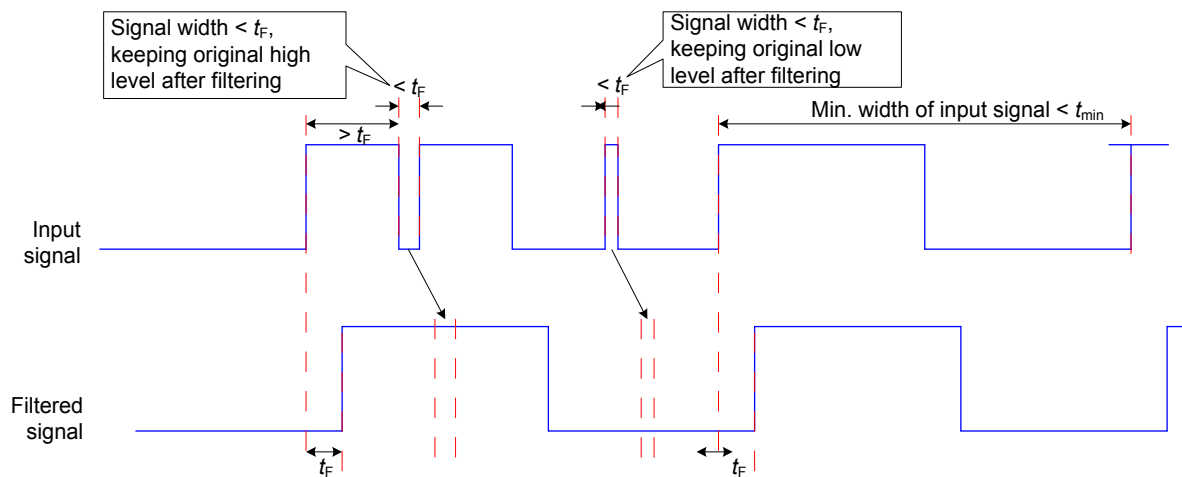

5

The filter time constant t_F must meet the requirement: $t_F \leq (20\% \sim 25\%)t_{min}$.

The recommended filter parameter setting based on the maximum frequency (minimum width) of input pulses is described in the following table.

Table 5-7 Recommended filter parameter setting

Pulse Input Terminal	Corresponding Function Code	Maximum Frequency of Input Pulses	Recommended Filter Time Constant (25 ns)
Low-speed pulse input terminal	H0A-24	< 167 k	30
		167 to 250 k	20
		250 to 500 k	10
High-speed pulse input terminal	H0A-30	500 k to 1 M	5
		> 1 M	3

For example, if the time constant is set to 30, the actual filter time is $30 \times 25 = 750$ ns.

■ Pulse input format

The servo drive supports three pulse input formats:

- Direction + pulse (positive or negative logic)
- Phase A + phase B quadrature pulse, 4-frequency multiplication
- CW + CCW

Select the pulse input format appropriate for the host controller or other pulse output device.

Relevant parameters:

Function Code	Parameter Name	Setting Range	Function	Property	Effective Time	Default
H05-15	Pulse input format	0: Direction + pulse, positive logic 1: Direction + pulse, negative logic 2: Phase A + phase B quadrature pulse, 4-frequency multiplication 3: CW + CCW	Select the pulse input format.	At stop	Power-on again	0

The following table describes the maximum frequencies and widths of position pulses from different terminals.

Table 5-8 Pulse input specifications

Input Terminal		Max. Frequency	Min. Time Width/us					
			t1	t23	t3	t4	t5	t6
High-speed pulse input terminal		4 Mpps	0.125	0.125	0.125	0.25	0.125	0.125
Low-speed pulse input terminal	Differential input	500 kpps	1	1	1	2	1	1
	Open collector input	200 kpps	2.5	2.5	2.5	5	2.5	2.5

5

The rising time and falling time of position pulses must be smaller than 0.1 us.

Pulse frequency

Set the maximum position pulse frequency in H0A-09. If the actual input pulse frequency is larger than H0A-09, Er.B01 will occur.

Relevant parameters:

Function Code	Parameter Name	Setting Range	Unit	Function	Property	Effective Time	Default
H0A-09	Maximum position pulse frequency	100 to 4000	kHz	Set the maximum frequency of external pulses.	At stop	Power-on again	4000

b. Step setting as the source (H05-00 = 1)



CAUTION

When the servo drive is in running state (S-ON signal active), the motor is in locked state if the step reference function is invalid, and rotates if this function is valid. After the H05-05 reference is executed, the function becomes invalid and the motor enters the locked state.

Step setting running means that the servo drive runs according to the internal fixed speed until the

displacement reference is completed. The setting flowchart is shown in the following figure.

Figure 5-25 Setting flowchart of step reference source

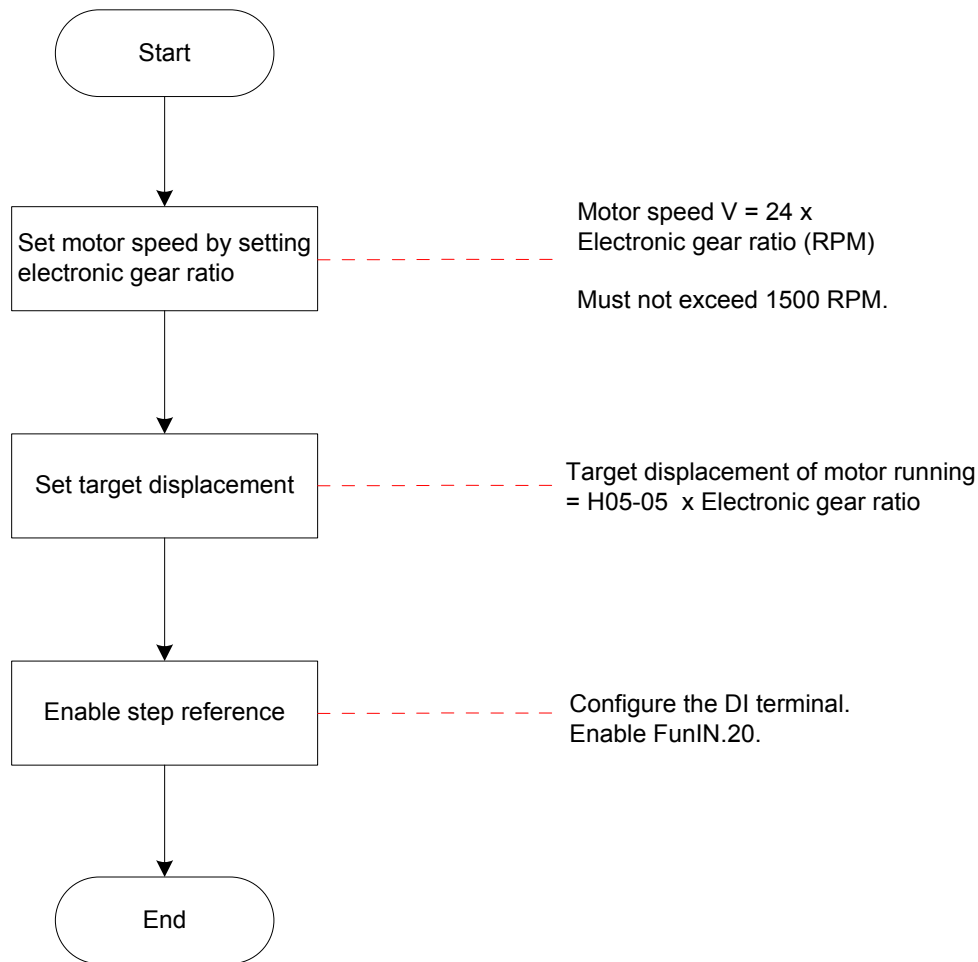

5

Figure 5-26 Motor running curve when $H05-00 = 1$

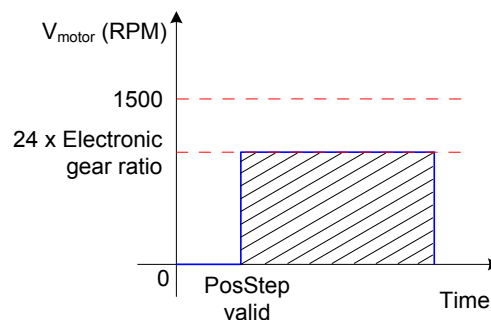

Motor displacement (shaded area in the figure) = $H05-05 \times$ Electronic gear ratio (encoder unit)

- Motor speed and electronic gear ratio

When the position reference source is step setting, the motor speed is set based on the electronic gear ratio. The motor speed in this case must not exceed 1500 RPM.

$$V_{\text{motor}} = 24 \times \text{Electronic gear ratio (RPM)}$$

- Motor displacement:

When the position reference source is step setting, the position reference sum (reference unit) is set in H05-05. Positive or negative of H05-05 value determines positive or negative of the motor speed.

Relevant parameters:

Function Code	Parameter Name	Setting Range	Unit	Function	Property	Effective Time	Default
H05-05	Step amount	-9999 to 9999	Reference unit	Set the position reference sum when H05-00 = 1. Positive or negative of the value determines positive or negative of the motor speed.	At stop	Immediate	50

Step reference

When using step setting as the position reference source, set a DI of the servo drive with function 20 (FunIN.20:PosStep, step reference), and set the DI terminal logic.

Relevant function No.:

No.	Function Symbol	Function Name	Description
FunIN.20	PosStep	Step reference	In servo running state Valid: Execute step reference set in H05-05, servo motor running Invalid: Servo motor in locked state

FunIN.20 (Step reference) is edge valid. After executing the step position reference, the servo motor enters the locked state. After FunIN.20 becomes valid again, the servo motor executes the position reference set in H05-05.

c. Multi-position reference as the source (H05-00 = 2)

The servo drive supports multi-position running. It stores 16 position references; the displacement, maximum running speed, and acceleration/deceleration time of each can be set. The waiting time and switch mode between positions can also be set according to actual requirements. The setting flowchart is shown in the following figure.

Figure 5-27 Setting flowchart of multi-position reference

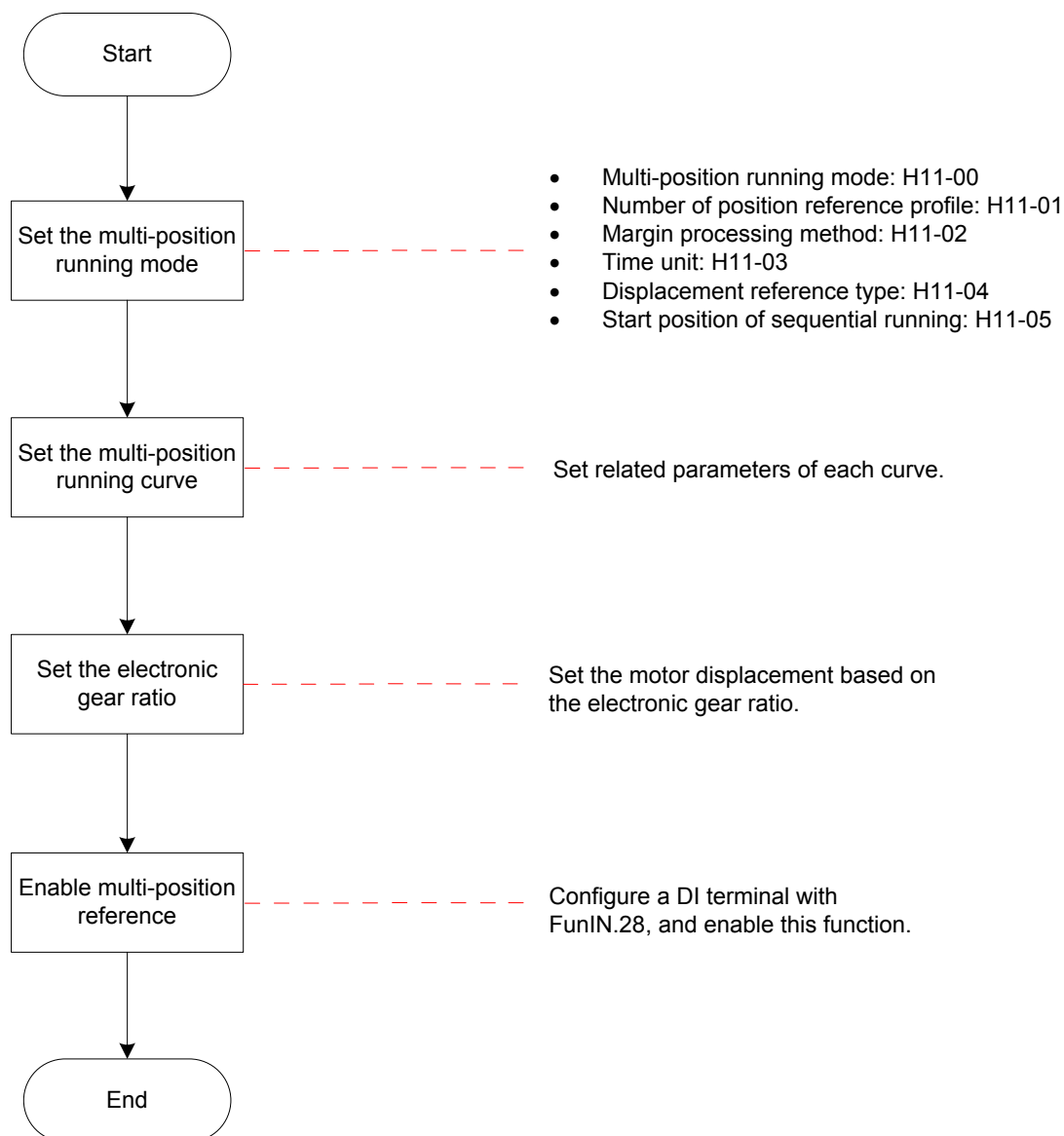

■ Setting of multi-position running mode

Relevant parameters:

Function Code	Parameter Name	Setting Range	Function	Property	Effective Time	Default
H11-00	Multi-position running mode	0: Stop after running single cycle 1: Cyclic running 2: DI switchover 3: Sequential running	Set the switchover mode between positions.	At stop	Immediate	1
H11-01	Number of position reference profile	1 to 16	Set the total number of positions in displacement reference.	At stop	Immediate	1
H11-02	Margin processing method	0: Complete the remaining distance 1: Start running again from 1st position	Set the start position No. when the multi-function running recovers after a pause. Note: This parameter is valid only when H11-00 ≠ 2.	At stop	Immediate	1
H11-03	Time unit	0: ms 1: s	Set the unit of the acceleration/deceleration time and waiting time. Note: The waiting time is valid only when H11-00 = 0 or 1.	At stop	Immediate	0
H11-04	Displacement reference type	0: Relative displacement reference 1: Absolute displacement reference	Set the displacement reference type.	At stop	Immediate	0
H11-05	Start position of sequential running	0 to 16	Set the start position No. after first cycle of running when H11-00 = 3. Note: H11-05 = 0 or H11-05 > H11-01: not cyclic. H11-05 > 1: The start position No. is H11-05 value.	At stop	Immediate	0

Stop after running single cycle (H11-00 = 0)

Table 5-9 Descriptions of single-cycle running

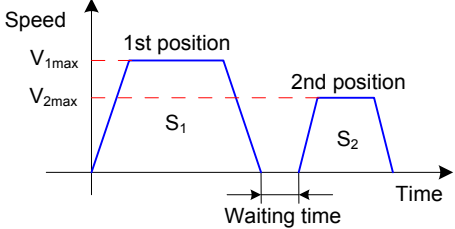
Mode Description	Running Curve
<ul style="list-style-type: none"> • The servo drive stops at one cycle- running. • The servo drive automatically switches to the next position with a larger No. • The waiting time can be set between positions. • The multi-position reference enable signal (FunIN.28: PosInSen) is level valid. 	<div style="text-align: center;">  </div> <p>V_{1max}, V_{2max}: maximum speeds of 1st and 2nd positions</p> <p>S_1, S_2: displacements of 1st and 2nd positions</p> <ul style="list-style-type: none"> • The positioning completion signal is active after each position is completed. • If the multi-position reference enable signal is turned off during running, the servo drive discards the uncompleted displacement and stops. After the stop process is completed, the positioning completion signal is active. • After the multi-position reference enable signal is turned on again, the servo drive starts running from the corresponding position according to H11-02 setting. • If the S-ON signal is turned off during running of a certain position, the motor stops according to the stop mode set in H02-05. After the motor is stopped, the positioning completion signal is inactive. • The DI logic change of position reference direction switchover (FunIN.27: PosDirSel) during running of a certain position does not affect the direction of this position running.

5

One-cycle running: The servo drive completes running the total number of positions set in H01-01.

Cyclic running (H11-00 = 1)

Table 5-10 Descriptions of cyclic running

Mode Description	Running Curve
<ul style="list-style-type: none"> • The servo drive repeats running from the 1st position after one-cycle running. • The servo drive automatically switches to the next position with a larger No. • The waiting time can be set between positions. • The cyclic running mode remains when the multi-position signal (FunIN.28: PosInSen) is active. • The multi-position reference enable signal (FunIN.28: PosInSen) is level valid. 	<div data-bbox="847 445 1298 686" style="text-align: center;"> <p>The graph plots Speed on the vertical axis and Time on the horizontal axis. It shows two trapezoidal speed profiles. The first profile, labeled '1st position' and 'S₁', starts at the origin, rises to a maximum speed V_{1max}, remains constant for a short duration, and then decelerates to zero. The second profile, labeled '2nd position' and 'S₂', starts after a 'Waiting time' interval, rises to a maximum speed V_{2max}, remains constant, and then decelerates to zero. Dashed horizontal lines indicate the levels of V_{1max} and V_{2max}.</p> </div> <p>V_{1max}, V_{2max}: maximum speeds of 1st and 2nd positions S_1, S_2: displacements of 1st and 2nd positions</p> <ul style="list-style-type: none"> • The positioning completion signal is active after each position is completed. • If the multi-position reference enable signal is turned off during running, the servo drive discards the uncompleted displacement and stops. After the stop process is completed, the positioning completion signal is active. • After the multi-position reference enable signal is turned on again, the servo drive starts running from the corresponding position according to H11-02 setting. • If the S-ON signal is turned off during running of a certain position, the motor stops according to the stop mode set in H02-05. After the motor is stopped, the positioning completion signal is inactive. • The logic change of the position reference direction switchover (FunIN.27: PosDirSel) during running of a certain position does not affect the direction of this position running.

DI switchover (H11-00 = 2)

Table 5-11 Descriptions of DI switchover

Mode Description	Running Curve
<ul style="list-style-type: none"> • The servo drive continues running when the position No. is updated. • The position No. is determined by the DI terminal logic. • The time interval between positions is determined by the delay time command from the host controller. • The multi-position reference enable signal (FunIN.28: PosInSen) is level valid. 	<div data-bbox="798 457 1302 782" style="text-align: center;"> </div> <p>x, y: position No.; for the relationship between the position No. and the DI terminal logic, see H11-01.</p> <p>S_x, S_y: displacements of xth and yth positions</p> <ul style="list-style-type: none"> • The positioning completion signal is active after each position is completed. • If the multi-position reference enable signal is turned off during running, the servo drive completes the remaining displacement, and outputs the positioning completion signal. • The position No. is switched over according to the following sequence: <ol style="list-style-type: none"> 1. The position No. cannot be switched over before the xth displacement is not completed. 2. During running of the xth displacement or after positioning is completed, set the multi-position reference enable signal inactive and switch over x to y (the servo drive executes the xth displacement again if $x = y$). 3. After the xth displacement is completed, the servo drive executes the yth displacement if you set the multi-position reference enable signal active. • If the S-ON signal is turned off during running of a certain position, the motor stops according to the stop mode set in H02-05. After the motor is stopped, the positioning completion signal is inactive. • The logic change of the position reference direction switchover (FunIN.27: PosDirSel) during running of a certain position does not affect the direction of this position running.

When the multi-position running mode is DI switchover, set four DI terminals with functions 6 to 9 (FunIN.6:CMD1 to FunIN.9:CMD4, multi-reference switchover) and set the terminal logic.

Figure 5-28 Multi-position time sequence

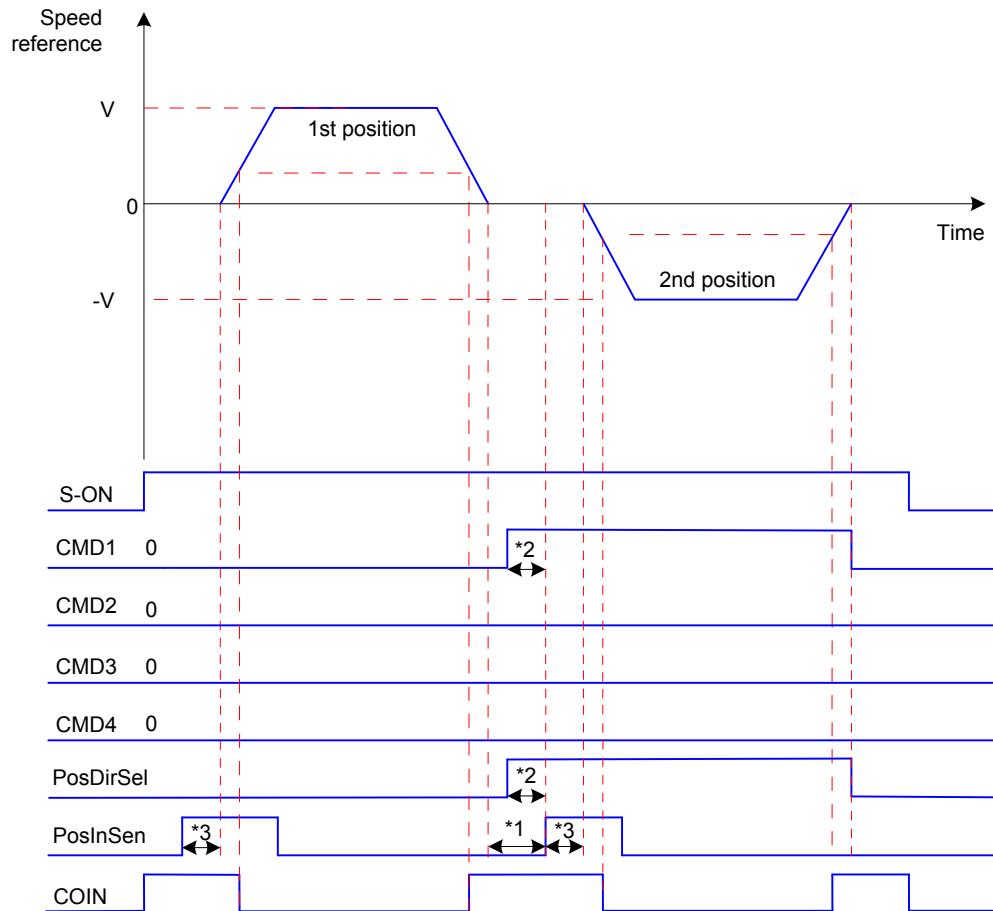

Note	<p>*1: Area for position No. switchover, that is, the previous position reference is issued, and the PosInSen signal for the next position becomes active again.</p> <p>*2: This signal remains active for at least 3 ms when the low-speed DI terminal is used.</p> <p>*3: The PosInSen signal is level valid. When using a low-speed DI terminal, ensure the effective signal width is at least 3 ms; when using a high-speed DI terminal, ensure the effective signal width is at least 0.25 ms.</p>
-------------	---

5

Relevant function No.:

No.	Function Symbol	Function Name	Description
FunIN.6	CMD1	Multi-reference switchover 1	The position No. is a 4-bit binary value, and the relationship between CMD1 to CMD4 and the position No. is listed in the following table.
FunIN.7	CMD2	Multi-reference switchover 2	
FunIN.8	CMD3	Multi-reference switchover 3	
FunIN.9	CMD4	Multi-reference switchover 4	
			The DI terminal logic is level valid. The signal is 1 when the input level is valid, and 0 when the input level is invalid.

Sequential running (H11-00 = 3)

Table 5-12 Descriptions of sequential running

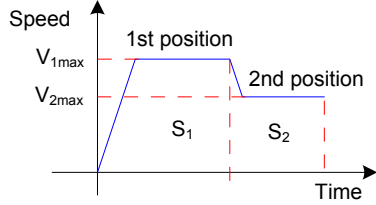
Mode Description	Running Curve
<ul style="list-style-type: none"> The servo drive stops after one-cycle running (H11-05 = 0 or H11-05 > H11-01). Cyclic running is supported, with continuing from position No. set in H11-05. The servo drive automatically switches to the next position with a larger No. There is no waiting time between positions. The multi-position reference enable signal (FunIN.28: PosInSen) is level valid. 	<div style="text-align: center;">  </div> <p>V_{1max}, V_{2max}: maximum speeds of 1st and 2nd positions S_1, S_2: displacements of 1st and 2nd positions</p> <ul style="list-style-type: none"> The positioning completion signal is active after each position is completed. If the multi-position reference enable signal is turned off during running, the servo drive discards the uncompleted displacement and stops. After the stop process is completed, the positioning completion signal becomes active. After the multi-position reference enable signal is turned on again, the servo drive starts running from the corresponding position according to H11-02 setting. If the servo ON signal is turned off during running of a certain position, the motor stops according to the stop mode set in H02-05. After the motor is stopped, the positioning completion signal becomes inactive. The logic change of the position reference direction switchover (FunIN.27: PosDirSel) during running of a certain position does not affect the direction of this position running.

5

When the multi-position function is used, a terminal must be set with function 28 (FunIN.28:PosInSen, multi-position reference enable); for the setting method, see the descriptions of group H03.

After each position reference is executed, the positioning completed signal (COIN) becomes active. To use this signal to check whether a position is completed, set a DO terminal with function 5 (FunOUT.5:COIN, positioning completed); for the setting method, see the descriptions of group H04.

Ensure that the S-ON signal is active during running of each position. Otherwise, the servo drive immediately stops according to the stop mode set in H02-05, and the positioning completed signal (COIN) becomes inactive after the servo drive is stopped.

In non-DI switchover mode, if S-ON signal is active and the multi-position function is disabled during the running of a certain position, the servo drive cancels the displacement command not sent and stops. The positioning completed signal (COIN) becomes active after the servo drive is stopped. After the multi-position function is enabled again, the start position No. is determined by H11-02.

■ Setting of multi-position running curve

The servo drive provides 16 position references, and the displacement, maximum running speed, and acceleration/deceleration time of each can be set. The following descriptions take the 1st position as an example.

Relevant parameters:

Function Code	Parameter Name	Setting Range	Unit	Function	Property	Effective Time	Default
H11-12	1st displacement	-1073741824 to 1073741824	Reference unit	Set the sum of 1st position reference.	During running	Immediate	10000
H11-14	Maximum running speed of 1st displacement	1 to 6000	RPM	Set the maximum running speed of the 1st displacement.	During running	Immediate	200
H11-15	Acceleration/Deceleration time of 1st displacement	0 to 65535	ms(s)	Set the time for the servo motor to change from 0 RPM to 1000 RPM for the 1st displacement.	During running	Immediate	10
H11-16	Waiting time after 1st displacement	0 to 10000	ms(s)	Set the waiting time after completion of 1st displacement.	During running	Immediate	10

The actual motor running curve according to the preceding setting is shown in the following figure.

Figure 5-29 Motor running curve of 1st displacement

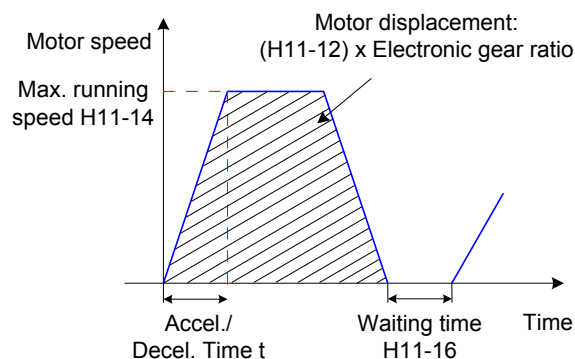

Actual time t of accelerating to H11-14:

$$t = \frac{(H11-14)}{1000} \times (H11-15)$$

For the parameter setting of the other 15 displacements, refer to Chapter 7.

Multi-position reference signal enable

When using multi-position reference as the position reference source, set a DI of the servo drive with function 28 (FunIN.28:PosInSen, multi-position reference enable), and set the DI terminal logic.

Relevant function No.:

No.	Function Symbol	Function Name	Description
FunIN.28	PosInSen	Multi-position reference enable	Invalid: Disabled, servo motor in locked state Valid: Enabled Note: When H11-00 = 0, 1, 3, the logic of the DI terminal with the PosInSen signal is level valid. When H11-00 = 2, the logic of the DI terminal with the PosInSen signal is edge change valid.

2) Position reference direction

A DI terminal is used to change the position reference direction and further the motor direction. Set a DI terminal of the servo drive with function 27 (FunIN.27:PosDirSel, position reference direction selection), and set the terminal logic.

Relevant function No.:

No.	Function Symbol	Function Name	Description
FunIN.27	PosDirSel	Position reference direction selection	Valid: Actual position reference direction same as given position reference direction Invalid: Actual position reference direction opposite to given position reference direction

The actual motor direction is related to the rotating direction in H02-02, positive/negative of position reference, position reference direction (FunIN.27).

Table 5-13 Motor rotating direction

H02-02	Positive/Negative of Position Reference	FunIN.27	Actual Motor Rotating Direction
0	+	Invalid	Counterclockwise
0	+	Valid	Clockwise
0	-	Invalid	Clockwise
0	-	Valid	Counterclockwise
1	+	Invalid	Clockwise
1	+	Valid	Counterclockwise
1	-	Invalid	Counterclockwise
1	-	Valid	Clockwise

3) Position reference inhibited

The servo drive provides the position reference inhibited function (FunIN.13: Inhibit) and pulse input inhibited function (FunIN.37:PulseInhibit).

Position reference inhibited function

The servo drive forces all position references to zero and does not respond to any internal or external position reference, and make the motor in position lock state. In this case, the servo drive can be switched over to other control modes.

When this function is enabled, the input position reference counter (H0B-13) continues to count the position references; when this function becomes disabled, the servo drive does not respond to the references counted earlier.

To use this function, configure a DI terminal of the servo drive with function 13 (FunIN.13: Inhibit, Position reference inhibited), and set the terminal logic. The high-speed DI terminal (DI8 or DI9) is recommended.

Figure 5-30 Waveform example of position reference inhibited function

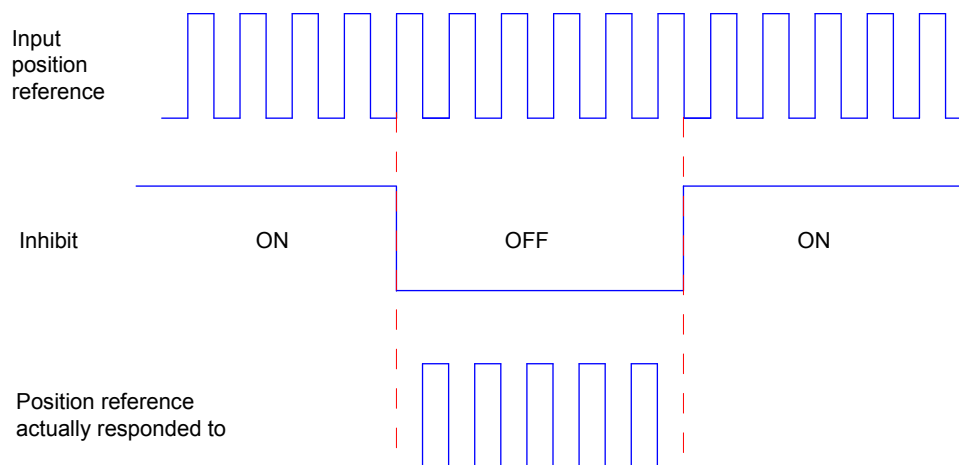

Relevant function No.:

No.	Function Symbol	Function Name	Description
FunIN.13	Inhibit	Position reference inhibited	Invalid: The servo drive responds to position references in position control mode. Valid: The servo drive does not respond to any internal or external position reference in position control mode.

b. Pulse input inhibited function

The servo drive forces pulses to zero and does not respond to pulses input from the pulse input terminal, but responds to position references of other sources. In this case, the servo drive can be switched over to other control modes.

When this function is enabled, if the position reference source is still pulse input in position control mode and the pulse input terminal continues to input pulse signals, the input position reference counter (H0B-13) continues to count the pulses, but the servo drive does not respond to them. If the position reference source is other forms, the counter in H0B-13 continues to count the position references, and the servo drive executes these references.

To use this function, configure a DI terminal of the servo drive with function 37 (FunIN.37: PulseInhibit, pulse input inhibited), and set the terminal logic. The high-speed DI terminal (DI8 or DI9) is recommended.

Figure 5-31 Waveform example of pulse input inhibited function

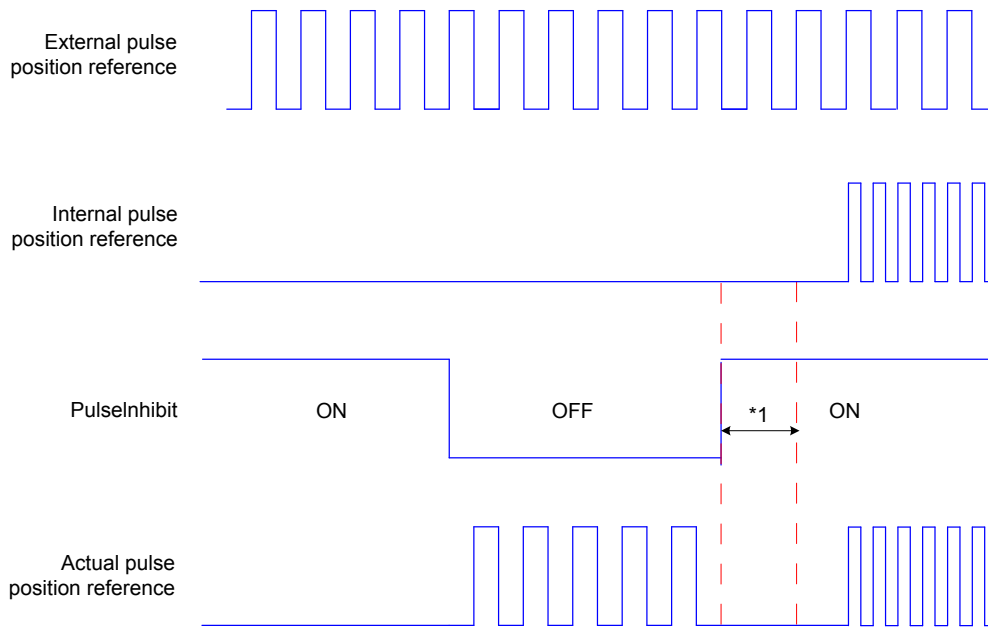

Note *1: When using a low-speed DI terminal, ensure the delay from input to response of DI terminal signal is at least 3 ms; when using a high-speed DI terminal, ensure the delay is at least 0.25 ms.

Relevant function No.:

No.	Function Symbol	Function Name	Description
FunIN.37	PulseInhibit	Pulse input inhibited	When the position reference source is pulse input (H05-00 = 0) in the position control mode: Invalid: Respond to pulse input Valid: Not respond to pulse input

5

5.2.2 Electronic Gear Ratio



The electronic gear ratio must be within the following range:

$$\frac{0.001 \times \text{Encoder resolution}}{10000} < \frac{B}{A} < \frac{4000 \times \text{Encoder resolution}}{10000}$$

Otherwise, Er.B03 is detected, indicating electronic gear ratio setting incorrect.
Incorrect electronic gear ratio setting causes running errors. Set it again in servo drive stop state.

1) Electronic gear ratio

In position control mode, the input position reference (reference unit) defines the load displacement; the motor position reference (encoder unit) defines the motor displacement. The electronic gear ratio is used to indicate the relationship between input position reference and motor position reference.

By dividing (electronic gear ratio < 1) or multiplying (electronic gear ratio >1) the electronic gear ratio, the actual motor rotating or moving displacement within the input position reference of one reference unit can be set.

Reference unit: It means the minimum value the host controller input to the servo drive.

Encoder unit: It means that the input reference processed with the electronic gear ratio.

2) Setting flowchart of electronic gear ratio

The electronic gear ratio varies according to the mechanical structure. Set it according to the following flowchart.

Figure 5-32 Setting flowchart of electronic gear ratio

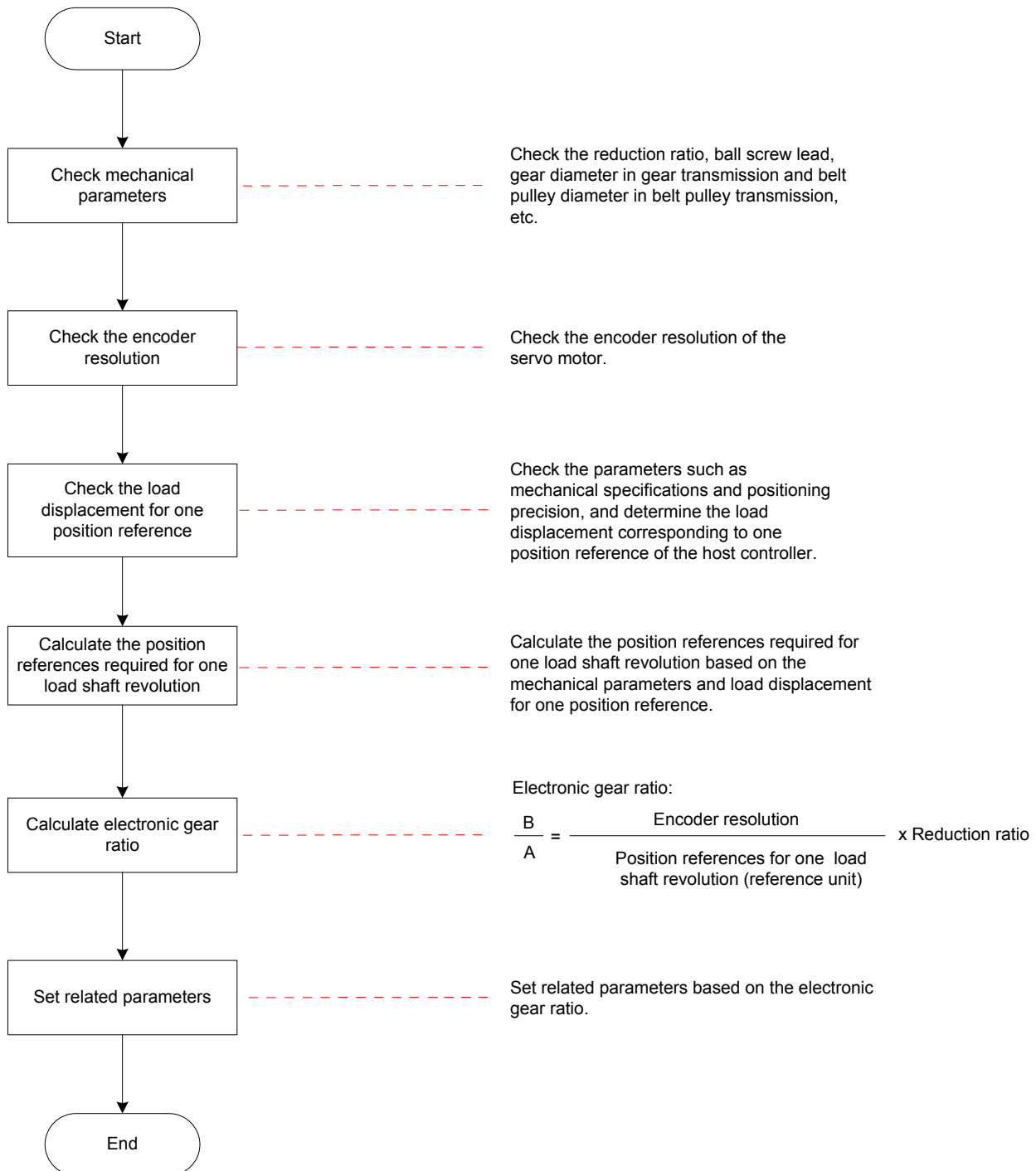

The method of parameter setting is shown in the following figure.

Figure 5-33 Setting the electronic gear ratio

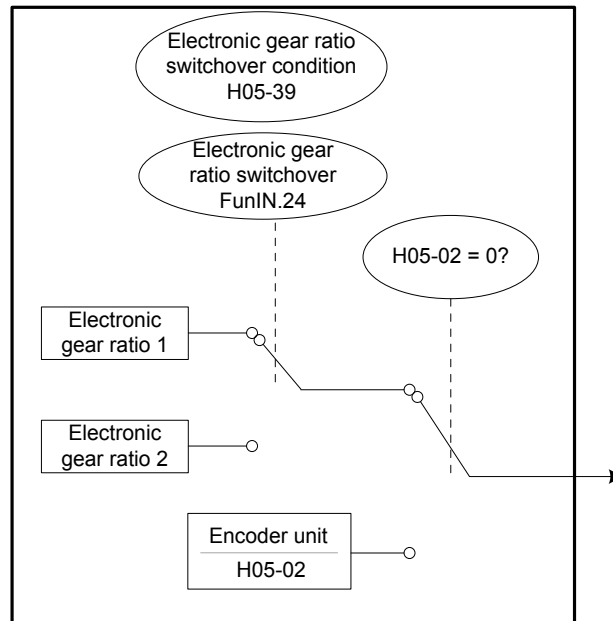

Note	When H05-02 ≠ 0: $\text{Electronic gear ratio} \frac{B}{A} = \frac{\text{Encoder resolution}}{H05-02}$ In this case, electronic gear ratio 1 and electronic gear ratio 2 are invalid.
-------------	--

3) Relevant parameters

a. Setting of electronic gear ratio

5

Relevant parameters:

Function Code	Parameter Name	Setting Range	Unit	Function	Property	Effective Time	Default
H05-02	Pulses per one motor revolution	0 to 1048576	P/r	Set the number of pulses required for one motor revolution.	Power-on again	Immediate	0
H05-07	Electronic gear ratio 1 (numerator)	1 to 1072741824	-	Set the numerator of electronic gear ratio 1.	During running	Immediate	1048576
H05-09	Electronic gear ratio 1 (denominator)	1 to 1073741824	-	Set the denominator of electronic gear ratio 1.	During running	Immediate	10000
H05-11	Electronic gear ratio 2 (numerator)	1 to 1073741824	-	Set the numerator of electronic gear ratio 2.	During running	Immediate	1048576
H05-13	Electronic gear ratio 2 (denominator)	1 to 1073741824	-	Set the denominator of electronic gear ratio 2.	During running	Immediate	10000

b. Setting of electronic gear ratio



Due to large difference between two electronic gear ratios, the motor speed fluctuates greatly during the switchover. Use the first-order low-pass filter function (H05-04) to make smooth switchover of position references.

When H05-02 = 0, electronic gear ratio switchover is supported. Determine whether switchover is necessary based on the mechanical running conditions and set the switchover conditions. Only one electronic gear ratio is effective at a moment.

Relevant parameters:

Function Code	Parameter Name	Setting Range	Function	Property	Effective Time	Default
H05-39	Electronic gear ratio switchover condition	0: Switchover if position reference = 0 and the duration reaches 2.5 ms 1: Real-time switchover	Set the electronic gear ratio switchover conditions.	At stop	Immediate	0

Set a DI terminal of the servo drive with function 24 (FunIN.27:GEAR_SEL, electronic gear ratio switchover), and set the terminal logic.

Relevant function No.:

No.	Function Symbol	Function Name	Description
FunIN.24	GEAR_SEL	Electronic gear ratio switchover	Invalid: Electronic gear ratio 1 Valid: Electronic gear ratio 2

The selected electronic gear ratio is described in the following table.

Table 5-14 Selection of electronic gear ratio

H05-02	H05-39	Level of DI terminal with FunIN.24	Electronic Gear Ratio
0	0	Invalid	$\frac{H05-07}{H05-09}$
		Valid	$\frac{H05-11}{H05-13}$
	1	Invalid	$\frac{H05-07}{H05-09}$
		Valid	$\frac{H05-11}{H05-13}$
1 to 1048576		-	-

Resolution of serial encoder = $2n(P/r)$, where "n" is the bits of the serial encoder.

For example, resolution of Inovance 20-bit serial encoder = $2^{20}(P/r) = 1048576(P/r)$.

Resolution of quadrature incremental encoder = Encoder PPR x 4

For example, resolution of Inovance quadrature 2500-PPR incremental encoder = $10000(P/r)$.

4) Calculation of electronic gear ratio

The following figure shows the relationship between the position reference (reference unit), load displacement, and electronic gear ratio.

Figure 5-34 relationship between the position reference (reference unit), load displacement, and electronic gear ratio.

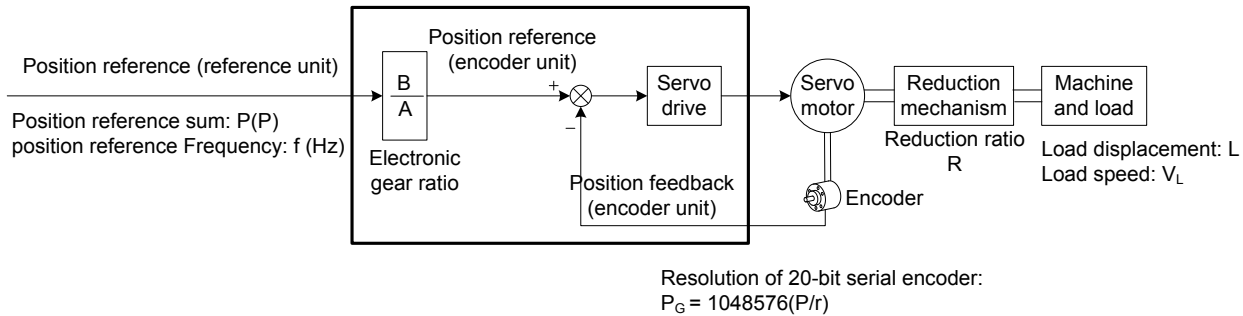

Take the load ball screw in linear movement as an example. Assume that the lead is p_B (mm), encoder resolution is P_G , and reduction ratio is R .

Figure 5-35 Ball screw diagram

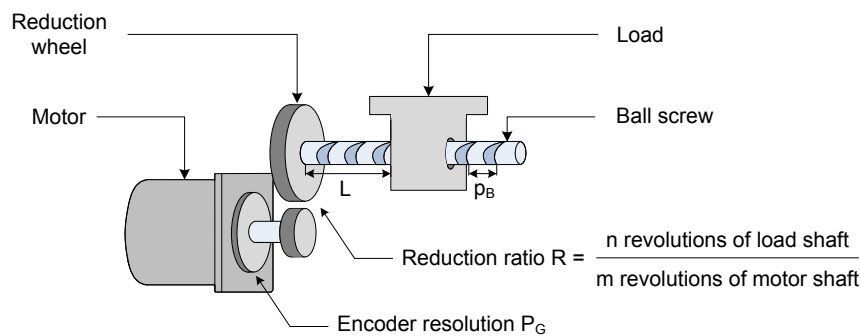

5

- Known that a pulse of the servo drive corresponds to load displacement ΔL (mm):

When the mechanical displacement is ΔL , correspondingly the load shaft rotates $\frac{\Delta L}{p_B}$ revolutions and the motor shaft rotates $\frac{\Delta L}{p_B} \times \frac{1}{R}$ revolutions.

Then, $1 \times \frac{B}{A} = \frac{\Delta L}{p_B} \times \frac{1}{R} \times P_G$

Electronic gear ratio $\frac{B}{A} = \frac{\Delta L}{p_B} \times \frac{1}{R} \times P_G$

- The load displacement L (mm) and position reference sum $P(P)$ are known.

When the mechanical displacement is L , correspondingly the load shaft rotates $\frac{L}{p_B}$ revolutions

and the motor shaft rotates $\frac{L}{p_B} \times \frac{1}{R}$ revolutions.

Then, $P \times \frac{B}{A} = \frac{L}{p_B} \times \frac{1}{R} \times P_G$

Electronic gear ratio $\frac{B}{A} = \frac{L}{p_B} \times \frac{1}{R} \times P_G \times \frac{1}{P}$

- The load moving speed V_L (mm/s) and position reference frequency f (Hz) are known.

Load shaft rotating speed: $\frac{V_L}{p_B}$ (r/s)

Motor speed: $v_M = \frac{V_L}{p_B} \times \frac{1}{R}$ (r/s)

Relationship between position reference frequency, electronic gear ratio and motor speed: $f \times \frac{B}{A} = v_M \times P_G$

$$\text{Electronic gear ratio } \frac{B}{A} = \frac{v_M \times P_G}{f}$$

5) Setting example of electronic gear ratio

Figure 5-36 Setting example of electronic gear ratio

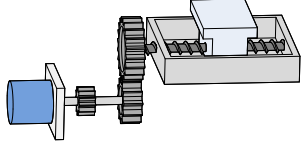
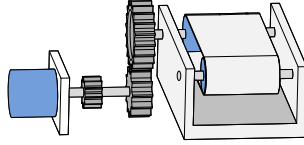
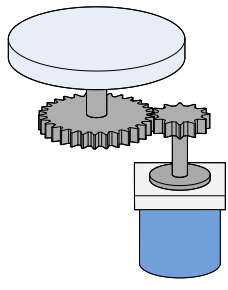
Step	Item	Mechanism		
		Ball Screw Transmission	Belt Pulley Transmission	Rotating Load
				
1	Mechanical parameters	Reduction ratio R: 1/1 Lead: 0.01 m	Reduction ratio R: 5/1 Diameter of belt pulley: 0.2 m (circumference: 0.628 m)	Reduction ratio R: 10/1 Load rotating angle for one load shaft revolution: 360°
2	Encoder resolution	20 bit = 1048576 P/r	20 bit = 1048576 P/r	20 bit = 1048576 P/r
3	Load displacement to one position reference (reference unit)	0.0001 m	0.000005 m	0.01°
4	Position references required for one load shaft revolution (reference unit)	$\frac{0.01}{0.0001} = 100$	$\frac{0.628}{0.000005} = 125600$	$\frac{360}{0.01} = 36000$
5	Calculation	$\frac{B}{A} = \frac{1048576}{100} \times \frac{1}{1}$	$\frac{B}{A} = \frac{1048576}{125600} \times \frac{5}{1}$	$\frac{B}{A} = \frac{1048576}{36000} \times \frac{10}{1}$
6	Setting	H05-07 = 1048576 H05-09 = 100	H05-07 = 5242880 H05-09 = 125600	H05-07 = 10485760 H05-09 = 36000

5

5.3.2 Position Reference Filter

This function filters the position references (encoder unit) divided or multiplied by the electronic gear ratio. It involves the first-order filter and moving average filter.

It is applicable to the following conditions:

Acceleration/Deceleration is absent on the position references from the host controller.

The pulse frequency is too low.

The electronic gear ratio is larger than 10.

Relevant parameters:

Function Code	Parameter Name	Setting Range	Unit	Function	Property	Effective Time	Default
H05-04	Time constant of first-order low-pass filter	0 to 6553.5	ms	Set the time constant of first-order low-pass filter for position reference (encoder unit).	At stop	Immediate	0.0
H05-06	Time constant of moving average filter	0 to 128.0	ms	Set the time constant of moving average filter for position reference (encoder unit).	At stop	Immediate	0.0

Note This function has no effect on the displacement (position reference sum).
If the setting is excessive, the response delay may be too large. Set the filter time constant based on actual conditions.

Figure 5-37 First-order and moving average filter of rectangular position reference

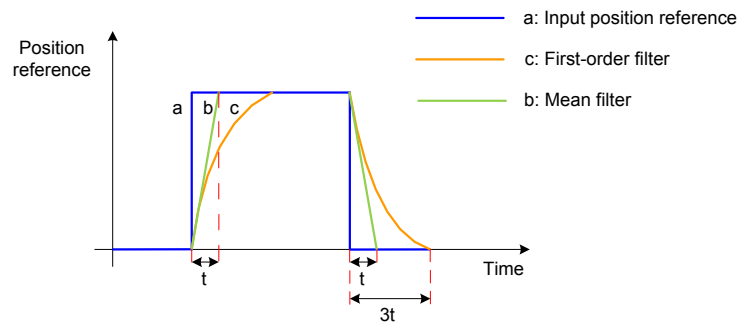
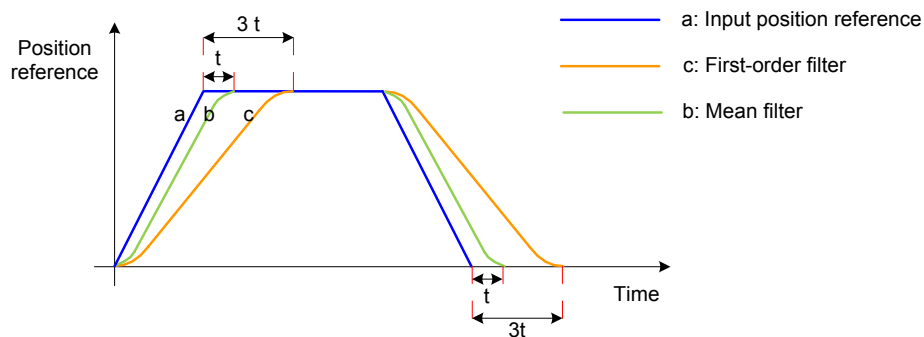

Figure 5-38 First-order and moving average filter of trapezoid position reference



5.2.4 Position Deviation Cleared

Position deviation = Position reference – Position feedback (encoder unit)

This function enables the servo drive to clear the position deviation when certain conditions are met (H05-16).

Relevant parameters:

Function Code	Parameter Name	Setting Range	Function	Property	Effective Time	Default
H05-16	Clear action	0: When S-ON is turned off or a fault occurs 1: When S-ON is turned off or a fault occurs 2: When S-ON is turned off and the ClrPosErr signal is input from DI	Set the conditions for clearing position deviation.	At stop	Immediate	0

When H05-16 = 2, set a DI terminal of the servo drive with function 35 (FunIN.35:ClrPosErr, position deviation cleared), and set the terminal logic. The high-speed DI terminal (DI8 or DI9) is recommended.

Relevant function No.:

No.	Function Symbol	Function Name	Description
FunIN.35	ClrPosErr	Position deviation cleared	Valid: Position deviation cleared Invalid: Position deviation not cleared

Table 5-15 Setting of position deviation cleared

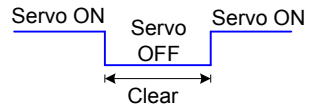
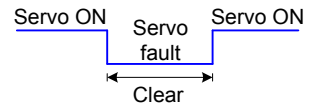
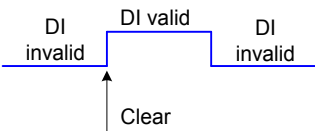
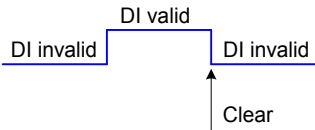
Setting	Clear Conditions	Clear Time
H05-16 = 0	The position deviation is cleared when the S-ON signal is turned off or the servo state is not "run".	
H05-16 = 1	The position deviation is cleared when the S-ON signal is turned off or a fault or warning occurs.	
H05-16 = 2	When position deviation is cleared when the S-ON signal is turned off or the DI terminal with this function is logic valid. The recommended logic is edge change valid.	 <p>(Rising edge valid)</p>
		 <p>(Falling edge valid)</p>

5.2.5. Frequency-Division Output



In full closed-loop control mode, the frequency-division output function cannot be used, and the frequency-division output terminal is used as the input terminal of external scale signal.

In applications requiring high precision of Z signal frequency-division output, the effective change edge of Z signal is recommended.

H05-41 = 0: The effective change edge is falling edge.

H05-41 = 1: The effective change edge is rising edge.

The frequency-division output function outputs the position reference pulses or encoder feedback position references as A/B phase quadrature pulses.

Figure 5-39 Schematic diagram of frequency-division output

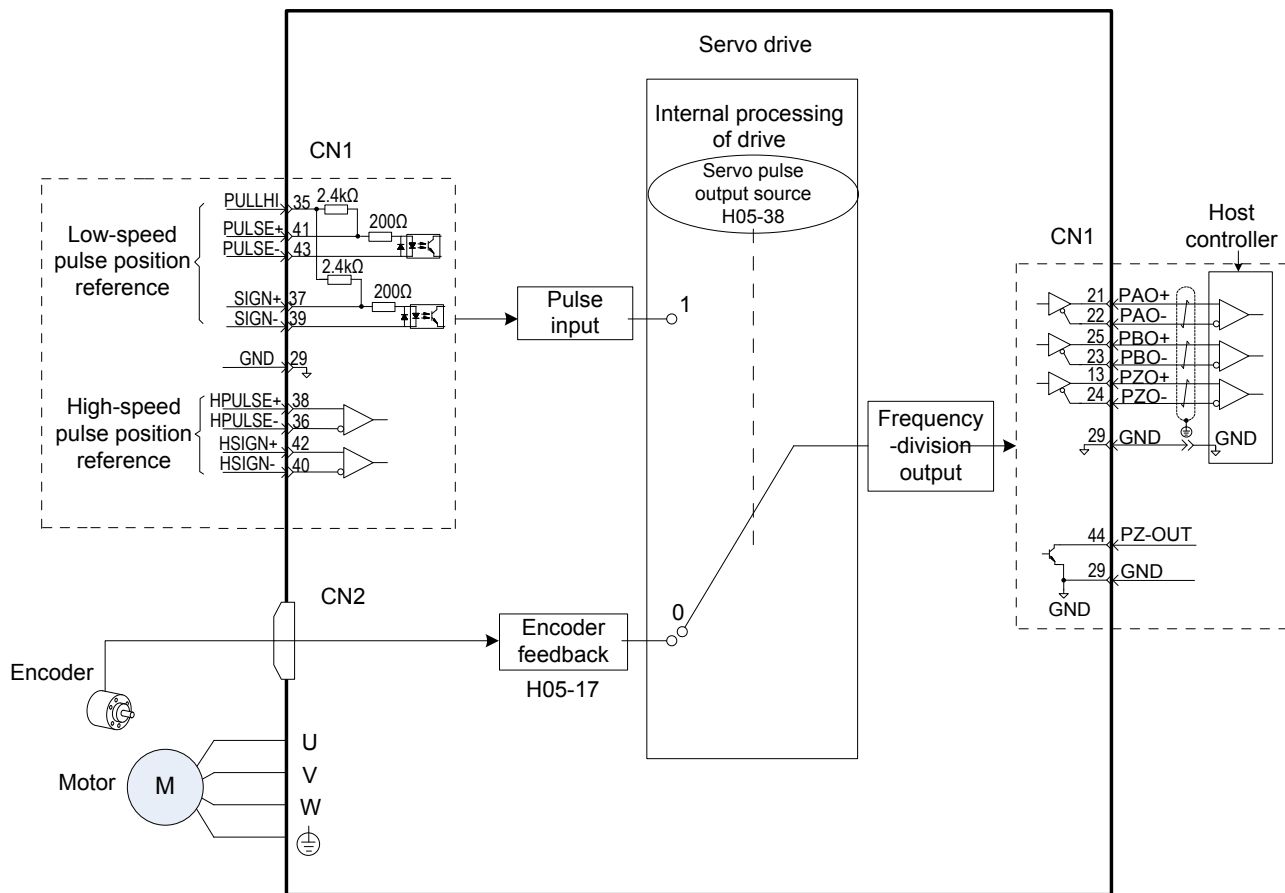

5

When pulse synchronous tracking of the multi-axis servo is required, pulse synchronous output (H05-38 = 1) is recommended; when the host controller provides closed-loop feedback, encoder frequency-division output (H05-38 = 0) is recommended.

The servo drive provides one frequency-division terminal, described in the following table.

Phase	Terminal	Output Format	Maximum Output Pulse Frequency
Phase A pulse	PAO+, PAO-	Differential output	2 Mpps
Phase B pulse	PBO+, PBO-	Differential output	2 Mpps
Phase Z pulse	PZO+, PZO-	Differential output	2 Mpps
PZ-OUT	GND	Open-collector output	100 kpps

When using the frequency-division output function, set the output pulse source (H05-38), phase (H02-03), resolution (H05-17), and phase Z pulse polarity (H05-41) according to requirements.

When the output source is encoder frequency-division pulse (H05-38 = 0), the phase A/B output pulses per motor revolution are determined by H05-17; phase A/B pulse width T is determined by the motor speed, and phase Z is synchronous with phase A and its width is T; Z signal is output once per motor revolution.

Table 5-16 Pulse diagram of encoder frequency-division output (H05-38 = 0)

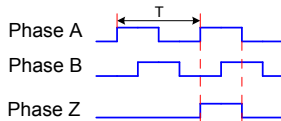
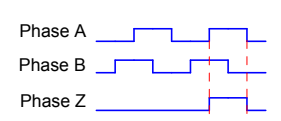
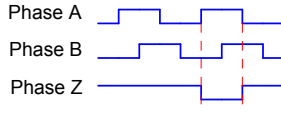
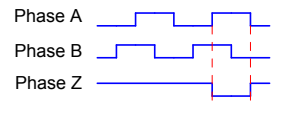
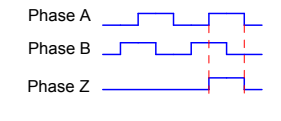
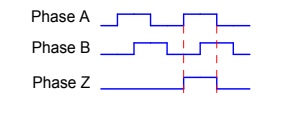
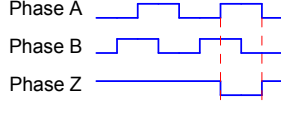
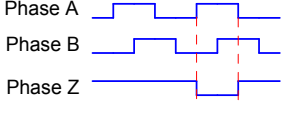
H02-03 (output pulse phase)	H05-41 (output polarity of Z pulse)	Pulse Output Diagram of Forward RUN	Pulse Output Diagram of Reverse RUN
0	0	 <p>Phase A advancing phase B by 90° .</p>	 <p>Phase B advancing phase A by 90° .</p>
	1	 <p>Phase A advancing phase B by 90° .</p>	 <p>Phase B advancing phase A by 90° .</p>
1	0	 <p>Phase B advancing phase A by 90° .</p>	 <p>Phase A advancing phase B by 90° .</p>
	1	 <p>Phase B advancing phase A by 90° .</p>	 <p>Phase A advancing phase B by 90° .</p>

Relevant parameters:

Function Code	Parameter Name	Setting Range	Unit	Function	Property	Effective Time	Default
H02-03	Output pulse phase	0: Phase A advancing phase B 1: Phase A lagging phase B	-	Set the phase relationship between phase A pulse and phase B pulse.	At stop	Power-on again	0

Function Code	Parameter Name	Setting Range	Unit	Function	Property	Effective Time	Default
H05-17	Encoder frequency-division pulses	35 to 32767	p/r	Set the number of pulses output by PAO or PBO (before 4-frequency multiplication) per motor revolution.	At stop	Power-on again	2500
H05-38	Servo pulse output source	0: Encoder frequency-division output 1: Pulse synchronous output 2: Frequency-division or synchronous output inhibited	-	Set the servo pulse output source.	At stop	Power-on again	0
H05-41	Output polarity of Z pulse	0: Positive (high level when pulse Z is valid) 1: Negative (low level when pulse Z is valid)	-	Set the output level when the phase Z pulse is valid.	At stop	Power-on again	1

5.2.6 Positioning Completed/Near Function

5

Positioning completed: When the position deviation meets the condition set in H05-20, the servo drive outputs the positioning completed signal (COIN); after receiving this signal, the host controller determines that positioning is completed.

The following figure shows the schematic diagram.

Figure 5-40 Diagram of positioning completed function

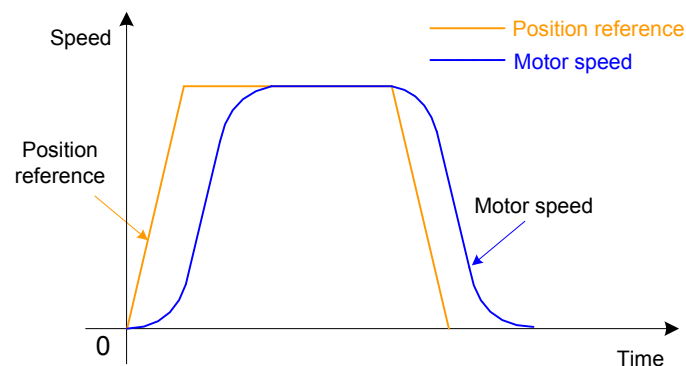

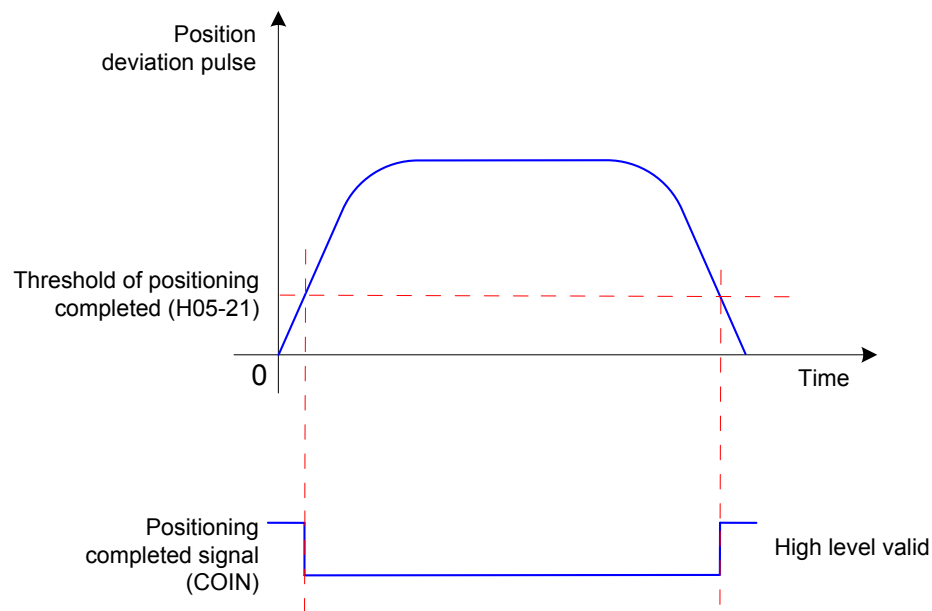
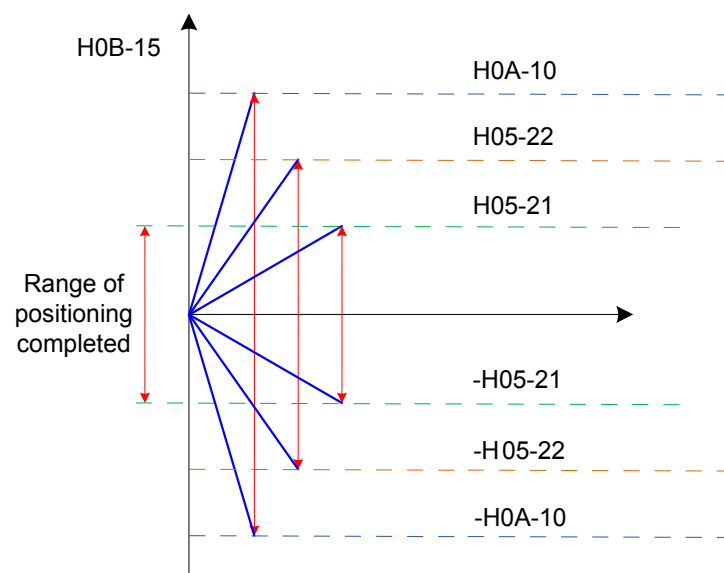

Figure 5-41 Position deviation-related signals



H0B-15: Encoder position deviation counter (encoder unit)

H0A-10: Threshold of position deviation excess

H05-22: Threshold of positioning near

H05-21: Threshold of positioning completed

When the position deviation meets the condition set in H05-20, the servo drive also outputs the positioning near signal (NEAR). The host controller sends the positioning near signal to the servo drive before confirming positioning completed, so that the servo drive prepares for the positioning completed action.

Before using the positioning completed/near function, set the output condition and threshold.

Relevant parameters:

Function Code	Parameter Name	Setting Range	Unit	Function	Property	Effective Time	Default
H05-20	Output condition of positioning completed/near signal (COIN)	0: Absolute value of position deviation is smaller than setting of H05-21/H05-22 1: Absolute value of position deviation is smaller than setting of H05-21/H05-22 and position reference after filter is 0 2: Absolute value of position deviation is smaller than setting of H05-21/H05-22 and position reference before filter is 0	-	Set the output condition of the positioning completed or near signal.	During running	Immediate	0
H05-21	Threshold of positioning completed	1 to 65535	Encoder unit	Set the absolute threshold of position deviation when servo drive outputs positioning completed signal.	During running	Immediate	734
H05-22	Threshold of positioning near	1 to 65535	Encoder unit	Set the absolute threshold of position deviation when servo drive outputs positioning near signal.	During running	Immediate	65535

5

**CAUTION**

H05-22 > H05-21

H05-21 reflects only the absolute threshold when the positioning completed signal is active. It is irrelevant to the positioning precision.

When the speed feedforward gain (H08-19) is large or the servo drive is in low-speed running, the absolute positioning deviation is relatively small. A large setting of H05-21 in this case may cause positioning completed signal always active. Decrease H05-21.

When both H05-21 and the position deviation are small, change the output condition of positioning completed signal in H05-20.

When the S-ON signal is inactive, the positioning completed signal (COIN) and positioning near signal (NEAR) are invalid.

To use the positioning completed and positioning near functions, set two DO terminals of the servo drive respectively with function 5 (FunOUT.5:COIN, positioning completed) and function 6 (FunOUT.6:NEAR, positioning near), and set the terminal logics.

Relevant function No.:

No.	Function Symbol	Function Name	Description
FunOut.5	COIN	Positioning completed	In the position control mode, when the position deviation pulses reach the value of H05-21, this signal is active.
FunOut.6	NEAR	Positioning near	In the position control mode, when the position deviation pulses reach the value of H05-22, this signal is active.

5.2.7 Position Change on Fly



CAUTION

The position change on fly signal cannot be turned on when the homing function is used.

1) Function description

This function allows the servo drive to interrupt during running and execute the preset position reference with fixed length in the position control mode. To be specific, when the S-ON signal is active in the position control mode, if this function is enabled, the servo motor runs the position reference for position change on fly in the original direction (before the function is triggered).

During running of this function, the servo drive shields any other internal or external position reference (including the position reference for this function triggered again), and the input position reference counter in H0B-13 counts only the position references for this function. After the running of this function is complete, the servo drive keeps shielding or responds to position references according to the setting of H05-29, but discards the position references input in the running process.

After the running of this function is complete, the servo drive outputs the position change on fly completed signal (FunOUT.15:XintCoin) and positioning completed signal (FunOUT.5:COIN) signal simultaneously. After receiving the position change on fly completed signal, the host controller confirms that the running of this function is complete. The output of the position change on fly completed signal is irrelevant to the S-ON signal and DI9 terminal logic.

This function takes effect on the following conditions:

Before this function is triggered, motor speed ≥ 10 RPM, H05-26 $\neq 0$.

H05-24 $\neq 0$

The DI FunIN.33 (Position change on fly inhibited) is not enabled or the logic of the terminal with this function is invalid.

Note

The moving average filter is invalid when the position change on fly function is used.

Figure 5-42 Setting flowchart of position change on fly function

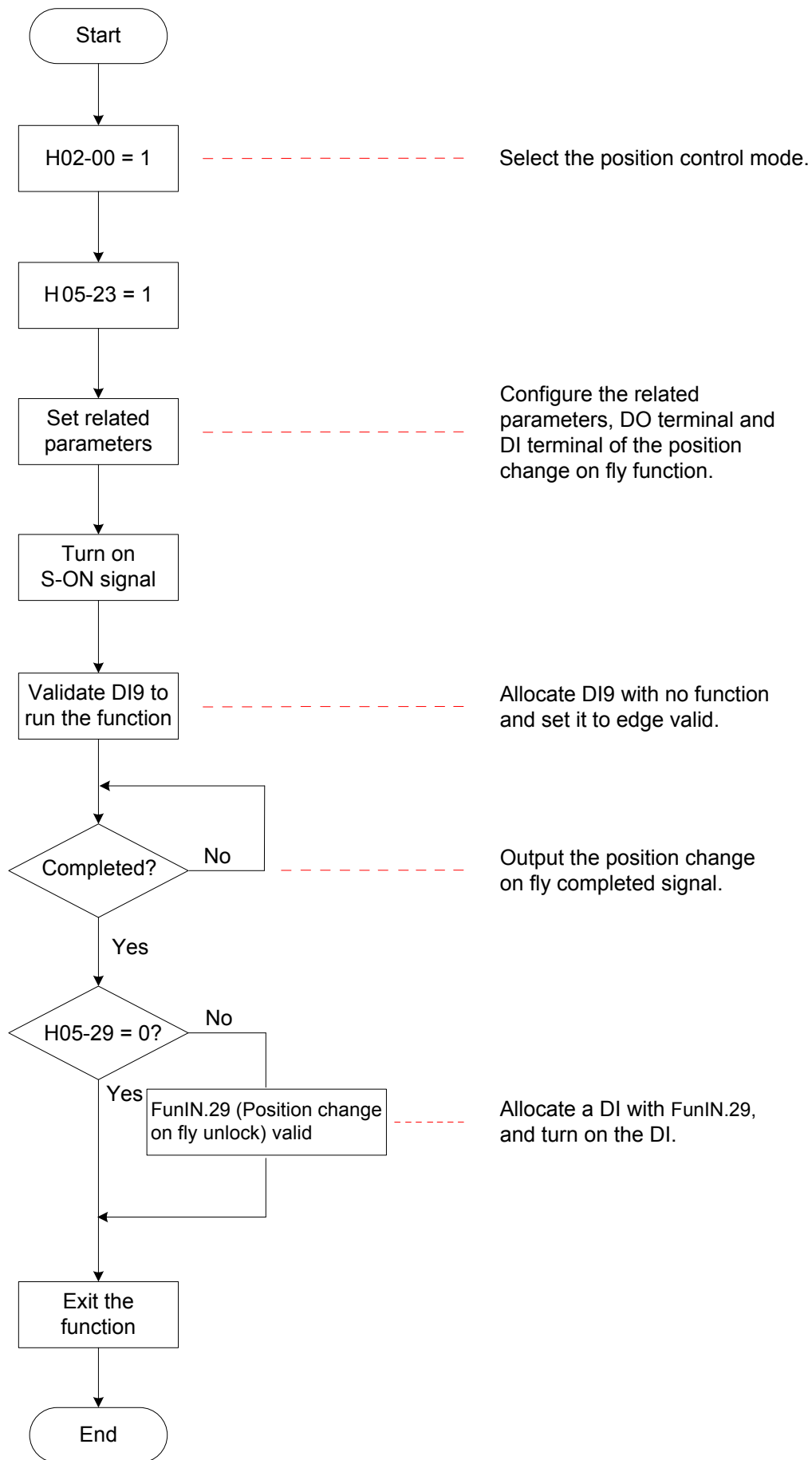

2) Parameter setting

Relevant parameters:

Function Code	Parameter Name	Setting Range	Unit	Function	Property	Effective Time	Default
H05-23	Position change on fly	0: Disabled 1: Enabled	-	Set whether to enable position change on fly.	At stop	Power-on again	0
H05-24	Displacement of position change on fly	0 to 1073741824	Reference unit	Set the displacement of position change on fly.	During running	Immediate	10000
H05-26	Constant speed for position change on fly	0 to 6000	RPM	Set maximum motor speed for position change on fly, irrelevant to the electronic gear ratio.	During running	Immediate	200
H05-27	Acceleration/Deceleration time of position change on fly	0 to 1000	ms	Set the time for motor to accelerate from 0 to 1000 RPM.	During running	Immediate	10
H05-29	Position change on fly unlock	0: Disabled 1: Enabled	-	Set the conditions of responding to other position references after the running of the position change on fly function is complete. When H05-29 = 1, a DI with FunIN.29 (Position change on fly unlock) must be used to exit the position change on fly function.	During running	Immediate	1

5

Relevant function No.:

No.	Function Symbol	Function Name	Description
FunIN.29	XintFree	Position change on fly unlock	Valid: The position change on fly state is unlocked, and the servo drive can respond to other position references. Invalid: The position change on fly signal is retained, and the servo drive does not respond to other position references.
FunIN.33	XintInHibit	Position change on fly inhibited	Valid: Position change on fly inhibited Invalid: Position change on fly permitted
FunOut.15	XintCoin	Position change on fly completed	Valid: Position change on fly completed Invalid: Position change on fly not completed



When using the position change on fly function, the servo drive forces the high-speed terminal DI9 as the triggering terminal; if allocated to other terminal, this function will be invalid. DI9 (H03-18) must not be allocated with other functions, and the terminal logic (H03-19) must be set to edge change valid. If not, the servo drive forces it to edge change valid.

Table 5-17 DI9 logic for the position change on fly function

H03-19	DI9 Logic	Waveform
0/3	Falling edge	
1/2	Rising edge	
4	Rising edge and falling edge	

The constant speed for position change on fly is shown in the following figure.

Figure 5-43 Motor running curve of position change on fly

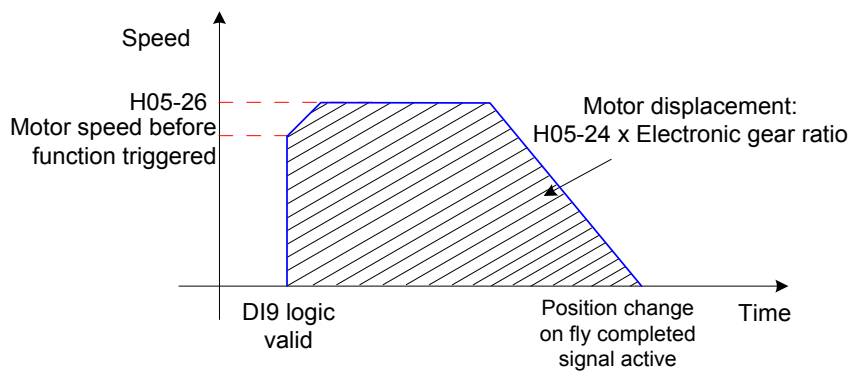

5

Table 5-18 Motor speed for position change on fly

H05-26	Motor Speed Before Function Triggered	Position Change on Fly Function	Constant Speed
0	< 10	Invalid	-
	≥ 10	Valid	Motor speed before the function is triggered
1 to 6000	-	Valid	H05-26

5.2.8 Homing



The homing signal is shielded when the position change on fly or multi-position function is running.

1) Function description

Home: It means the mechanical home reference point, that is, the position of the home switch or motor Z signal, determined by H05-31.

Zero: positioning target point, expressed as home + offset (set in H05-36). When H05-36 = 0, the zero position is the same as the home.

Homing function: When the S-ON signal is active in the position control mode, the servo motor proactively searches for the zero position and completes positioning if the homing function is triggered.

During the homing operation, the servo drive shields the other position references (including the homing reference triggered again). After the homing operation is complete, the servo drive can respond to other position references.

This function includes two actions:

- Home attaining: After receiving the homing signal, the servo drive proactively locates the relative position between the motor shaft and the preset mechanical home reference point; it finds the home and then moves through the offset from the home reference point to the zero point. This mode is used for finding the zero position for the first time.
- Electric home attaining: After finding the absolute zero position, the servo drive moves a certain displacement from the current position.

After the homing operation is completed (including home attaining and electric home attaining), the absolute motor position (H0B-07) is the same as the mechanical home offset (H05-36).

After the homing operation is completed, the servo drive outputs the home attaining completed signal (FunOUT.16: HomeAttain) or electric home attaining completed signal (FunOUT.17: ElecHomeAttain). After receiving this signal, the host controller confirms that the homing operation is completed. These two signals are irrelevant to the servo mode and running state.

Table 5-19 Comparison between home attaining and electric home attaining

Action	Homing Enabling Method (H05-30)	Actuation Direction, Deceleration Point, Home	Signal	Total Motor Displacement
Home attaining	0	-	-	-
	1	Determined by H05-31	HomingStart signal	Determined by the mechanical home coordinate and offset displacement
	3		S-ON signal	
	4		S-ON signal	
	6	-	-	-
Electric home attaining	2	The actuation direction is consistent with the motor displacement symbol (+/-). The deceleration point and home signals are not required.	HomingStart signal	(H05-36 – H0B-07) x Electronic gear ratio
	5		S-ON signal	

Note	Both the moving average filter and low-pass filter are invalid when the homing function is used.
-------------	--

2) Home attaining



Before using the homing function, set the mechanical limit switches to prevent the machine from being crashed due to the high speed during the homing process.

If the motor reaches the limit switch during homing, the servo drive reports Dr.950 (Forward limit warning) or Dr.952 (Reverse limit warning). If H05-40 = 0 or 1, the motor stops according to the mode set in H02-07.

The following part takes an example to describe homing attaining:

H05-31 = 0: Forward direction, deceleration point and home being home switch signal

H05-31 = 2: Forward direction, deceleration point and home being motor Z signal

H05-31 = 4: Forward direction, deceleration point being home switch signal and home being motor Z signal

H05-31 = 6: Forward direction, deceleration point and home being forward limit switch signal

H05-31 = 8: Forward direction, deceleration point being forward limit switch signal and home being motor Z signal

The other home attaining modes are the same as the above except that the direction is opposite.

a. H05-31 = 0: Forward direction, deceleration point and home being home switch signal

- The home switch (deceleration point) signal is inactive (0: inactive, 1: active) when the motor starts to run, and the forward limit switch is not sensed in the entire process.

The running process is as follows:

The servo motor searches for the deceleration point signal in forward direction at high speed set in H05-32.

After reaching the rising edge of the deceleration point signal, the motor decelerates to $-(H05-33)$ according to the time set in H05-34.

The motor searches for the falling edge of the deceleration point signal in reverse direction at low speed of $-(H05-33)$.

After reaching the falling edge of the deceleration point signal, the motor then changes to forward direction, and searches for the rising edge of the home signal at the speed of H05-33. During forward acceleration or forward constant speed running, the motor stops immediately after reaching the rising edge of the home signal.

Figure 5-44 Motor running curve 1 and speeds in Mode 0

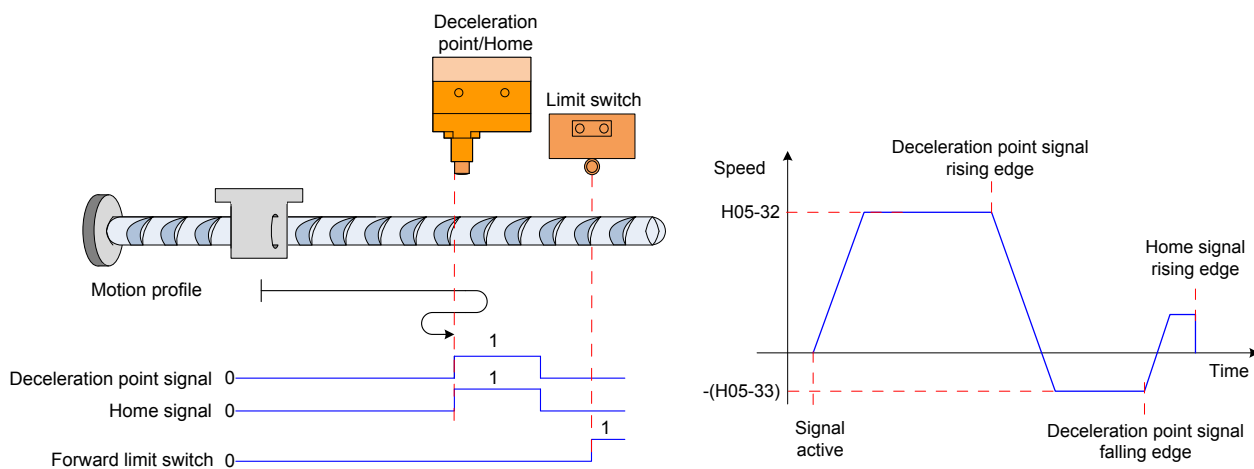

- The home switch (deceleration point) signal is active when the motor starts to run, and the forward limit switch is not sensed in the entire process.

The running process is as follows:

The servo motor directly searches for the falling edge of the deceleration point signal in reverse direction at low speed of $-(H05-33)$.

After reaching the falling edge of the deceleration point signal, the motor changes to forward direction, and searches for the rising edge of the home signal at low speed of H05-33.

During forward acceleration or forward constant speed running, the motor stops immediately after reaching the rising edge of the home signal.

Figure 5-45 Motor running curve 2 and speeds in Mode 0

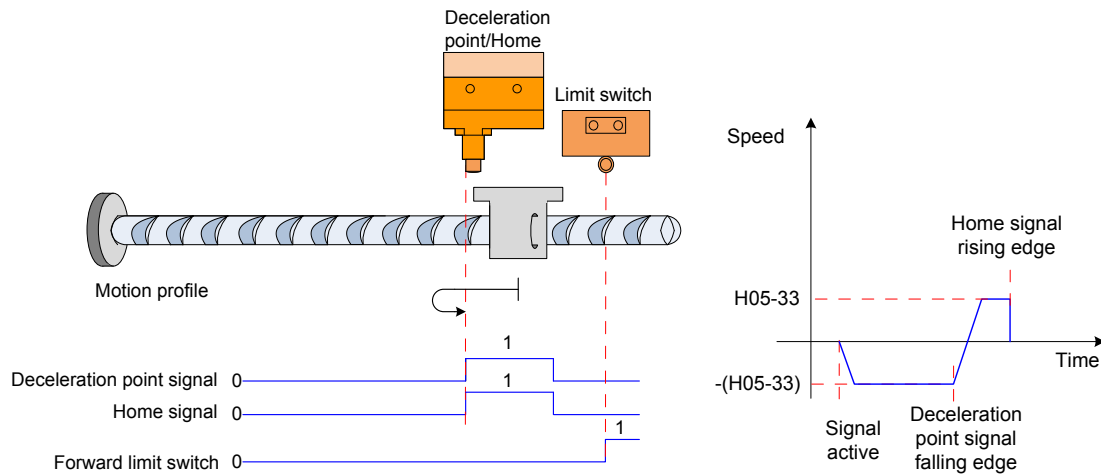

- The home switch (deceleration point) signal is inactive when the motor starts to run, and the forward limit switch is sensed in the process.

The servo motor searches for the deceleration point signal in forward direction at high speed of H05-32.

After sensing the forward limit switch, the servo drive implements immediate reverse home attaining (H05-40 = 2 or 3) or stops and waits for the home attaining signal re-issued by the host controller (H05-40 = 0 or 1).

After the condition is met, the motor searches for the falling edge of the deceleration point signal in reverse direction at high speed of -(H05-32).

After reaching the falling edge of the deceleration point signal, the motor then decelerates and restores to forward direction according to the time set in H05-34, and searches for the rising edge of the home signal at the speed of H05-33.

During forward acceleration or forward constant speed running, the motor stops immediately after reaching the rising edge of the home signal.

Figure 5-46 Motor running curve 3 and speeds in Mode 0

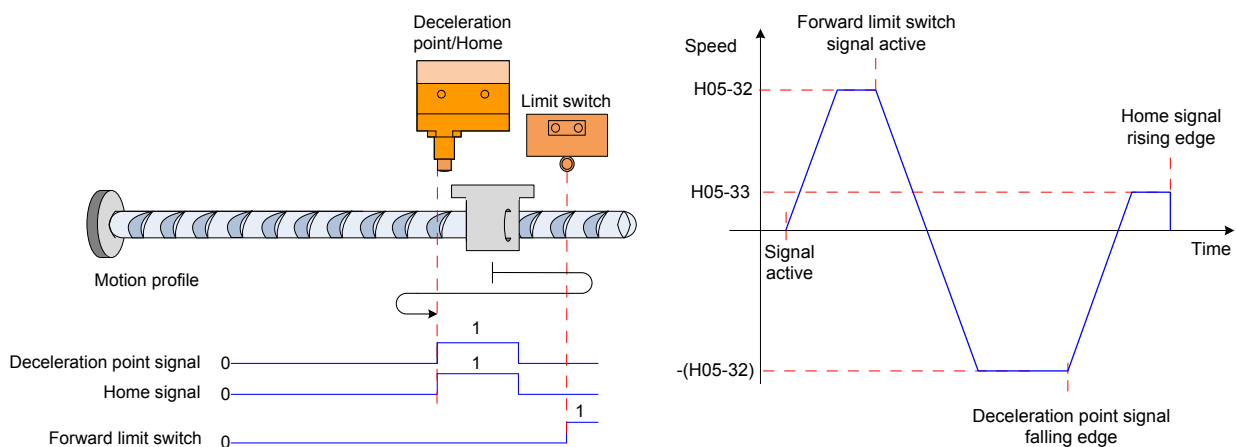

- b. H05-31 = 2: Forward direction, deceleration point and home being motor Z signal



In the mode where Z signal is used to judge the deceleration point and home (H05-31 = 2 or 3), the actual motor stop position may be on a different side from the rising edge of Z signal, and there is a deviation of ± 1 pulse (encoder unit).

- The Z signal is inactive (0: inactive, 1: active) when the motor starts to run, and the forward limit switch is not sensed in the entire process.

The running process is as follows:

The servo motor searches for Z signal in forward direction at high speed of H05-32.

After reaching the rising edge of Z signal, the motor then decelerates and changes to reverse direction according to the time set in H05-34, and accelerates to $-(H05-33)$.

During reverse acceleration or reverse constant speed running, the motor immediately stops after reaching motor Z signal rising edge of the other side.

Figure 5-47 Motor running curve 1 and speeds in Mode 2

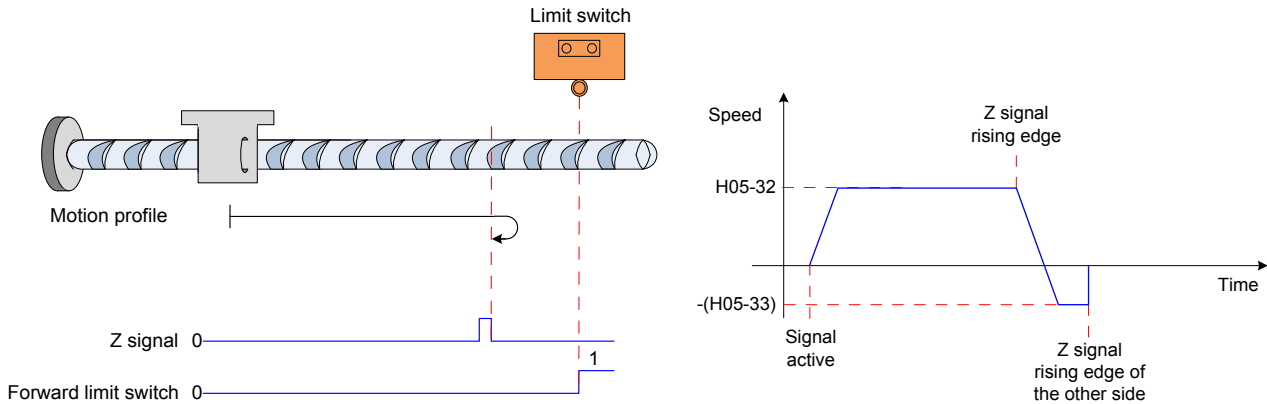

- The Z signal is active when the motor starts to run, and the forward limit switch is not sensed in the entire process.

The running process is as follows:

The servo motor directly searches for the falling edge of Z signal in forward direction at low speed of H05-33.

After reaching the falling edge of Z signal, the motor changes to reverse direction, and searches for the rising edge of Z signal at low speed of $-(H05-33)$.

During reverse acceleration or reverse constant speed running, the motor stops immediately after reaching the rising edge of Z signal.

Figure 5-48 Motor running curve 2 and speeds in Mode 2

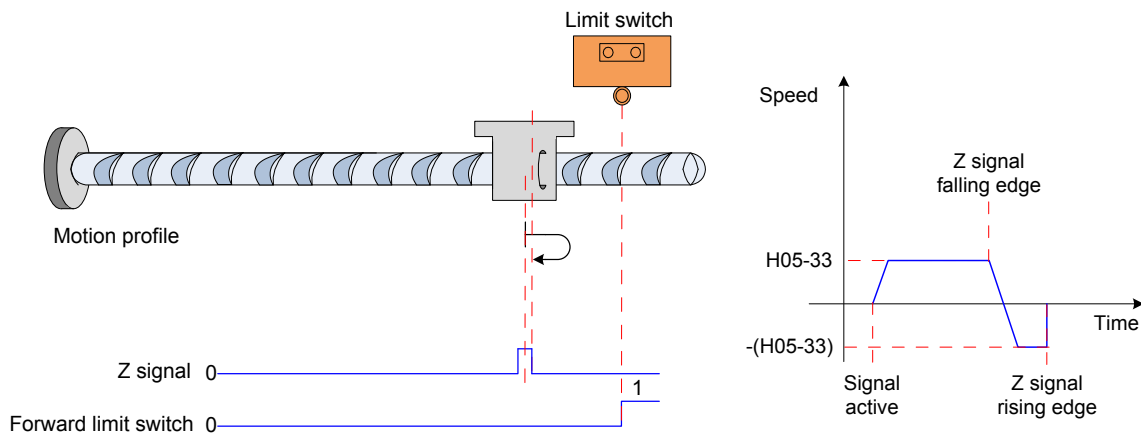

- The Z signal is inactive when the motor starts to run, and the forward limit switch is sensed in the process.

The servo motor searches for Z signal in forward direction at high speed of H05-32.

After sensing the forward limit switch, the servo drive implements immediate reverse home attaining ($H05-40 = 2$ or 3) or stops and waits for the home attaining signal re-issued by the host controller ($H05-40 = 0$ or 1).

After the condition is met, the motor searches for Z signal in reverse direction at high speed of $-(H05-32)$.

After reaching the rising edge of Z signal, the motor then decelerates and restores to forward direction according to the time set in H05-34, and searches for Z signal rising edge of the other side at low speed of H05-33.

During forward acceleration or forward constant speed running, the motor stops immediately after reaching Z signal rising edge of the other side.

Figure 5-49 Motor running curve 3 and speeds in Mode 2

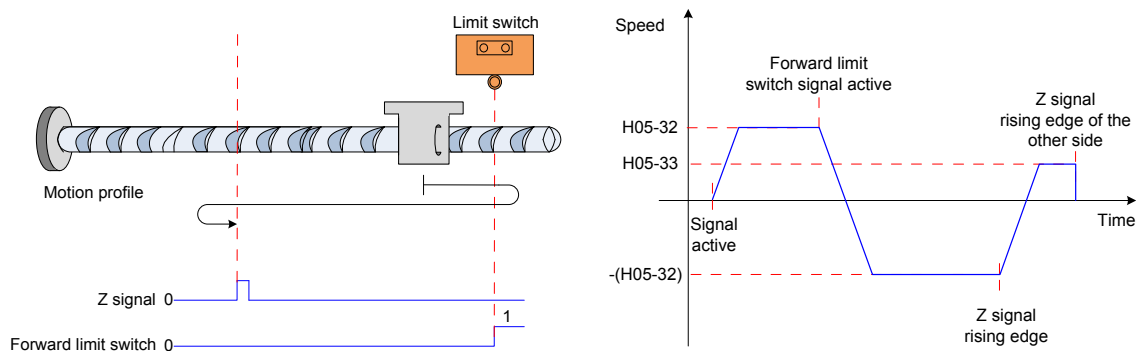

- c. $H05-31 = 4$: Forward home direction, deceleration point being home switch signal and home

being motor Z signal

- The home switch signal is inactive (0: inactive, 1: active) when the motor starts to run, and the forward limit switch is not sensed in the entire process.

The running process is as follows:

The servo motor searches for the home switch signal in forward direction at high speed of H05-32. After reaching the rising edge of the home switch signal, the motor then decelerates and changes to reverse direction according to the time set in H05-34, and searches for the falling edge of the home switch signal at low speed of $-(H05-33)$.

After reaching the falling edge of the home switch signal, the motor decelerates and restores to forward direction, and searches for the rising edge of the home switch signal at low speed of H05-33. After reaching the rising edge of the home switch signal, the motor continues to run and immediately stops after reaching Z signal for the first time.

Figure 5-50 Motor running curve 1 and speeds in Mode 4

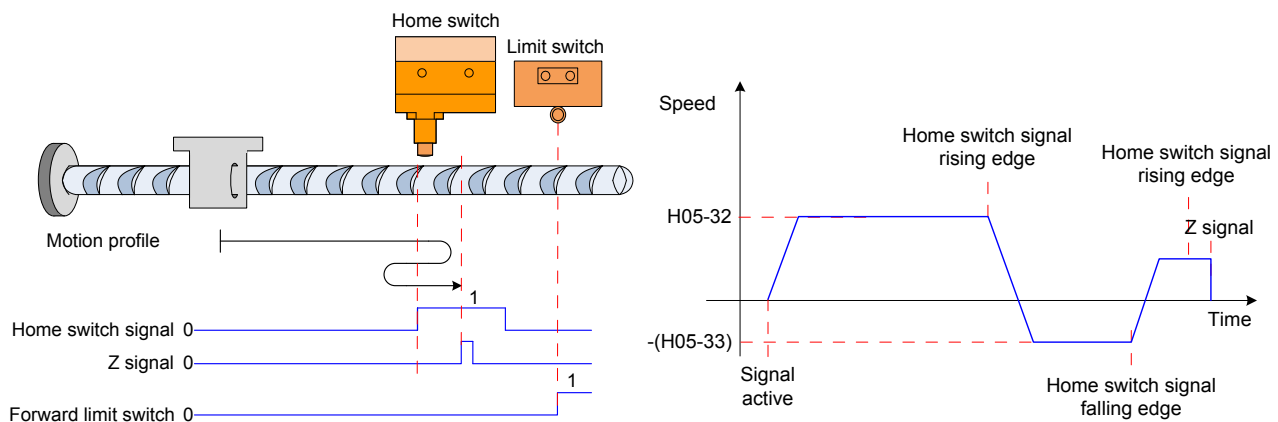

- The home switch signal is active when the motor starts to run, and the forward limit switch is not sensed in the entire process.

The running process is as follows:

The servo motor directly searches for the falling edge of the home switch signal in reverse direction at low speed of $-(H05-33)$.

After reaching the falling edge of the home switch signal, the motor decelerates and restores to forward direction, and searches for the rising edge of the home switch signal at low speed of H05-33. After reaching the rising edge of the home switch signal, the motor continues to run in forward direction at low speed of H05-33, and stops immediately after reaching Z signal for the first time.

Figure 5-51 Motor running curve 2 and speeds in Mode 4

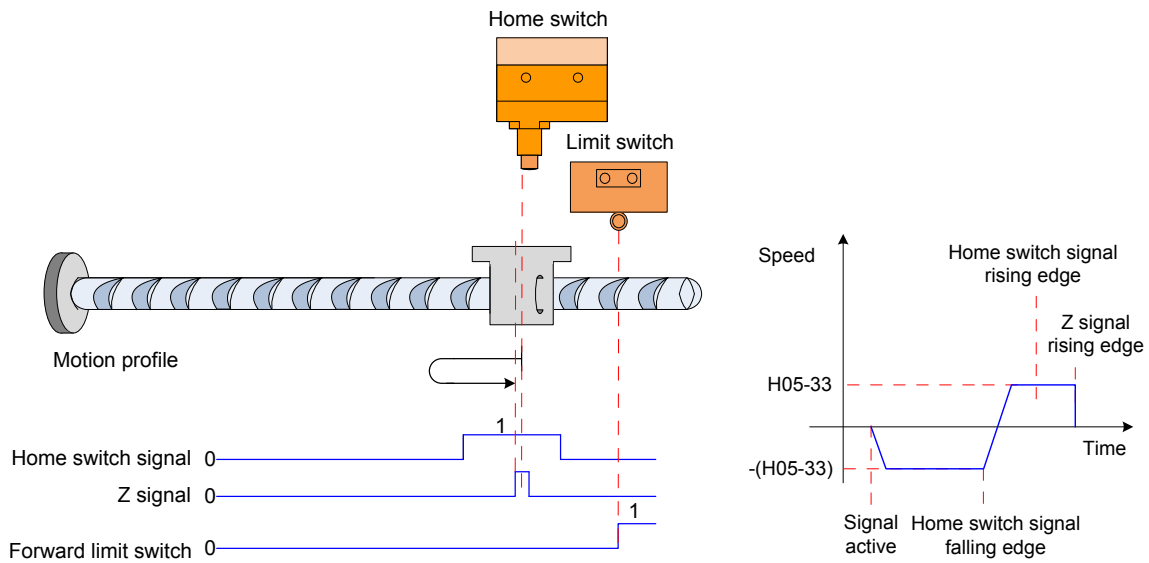

- The home switch signal is inactive when the motor starts to run, and the forward limit switch is sensed in the process.

The servo motor searches for the home switch signal in forward direction at high speed of H05-32. After sensing the forward limit switch, the servo drive implements immediate reverse home attaining (H05-40 = 2 or 3) or stops and waits for the home attaining signal re-issued by the host controller (H05-40 = 0 or 1).

After the condition is met, the motor searches for the deceleration point signal in reverse direction at high speed of -(H05-32).

After reaching the falling edge of the home switch signal, the motor then decelerates and restores to forward direction according to the time set in H05-34, and searches for the rising edge of the home switch signal at low speed of H05-33.

After reaching the rising edge of the home switch signal, the motor continues to run and stops immediately after reaching Z signal for the first time.

Figure 5-52 Motor running curve 3 and speeds in Mode 4

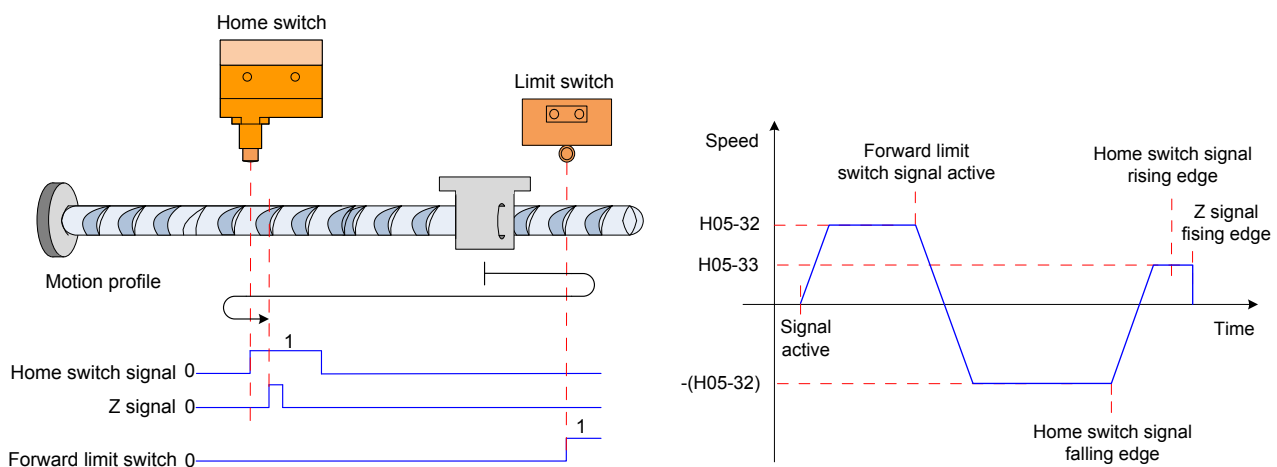

d. H05-31 = 6: Forward direction, deceleration point and home being forward limit switch signal

- The forward limit switch signal is inactive (0: inactive, 1: active) when the motor starts to run.

The running process is as follows:

The servo motor searches for the forward limit switch signal in forward direction at high speed of H05-32.

After reaching the rising edge of the forward limit switch signal, the motor then decelerates and changes to reverse direction according to the time set in H05-34, and searches for the falling edge of the forward limit switch signal at low speed of $-(H05-33)$.

After reaching the falling edge of the forward limit switch signal, the motor decelerates and restores to forward direction, and searches for the rising edge of the forward limit switch signal at low speed of H05-33.

During forward acceleration or forward constant speed running, the motor stops immediately after reaching the rising edge of the forward limit switch signal.

Figure 5-53 Motor running curve 1 and speeds in Mode 6

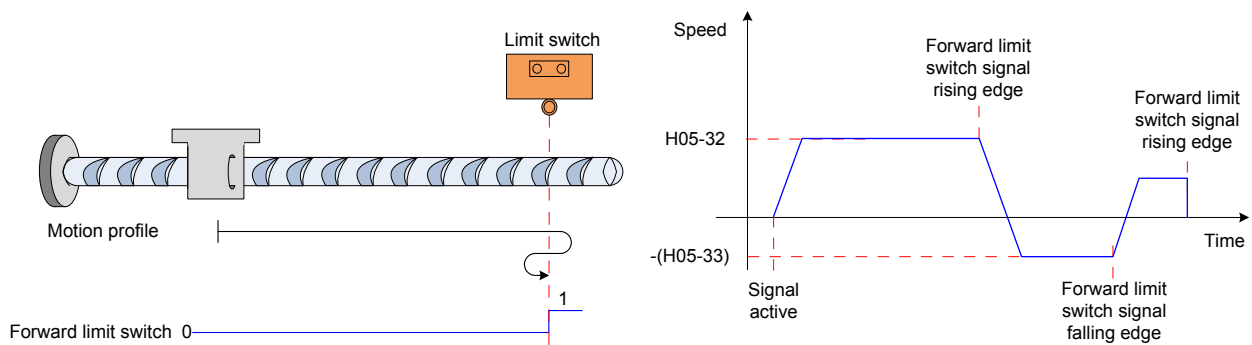

5

- The forward limit switch signal is active when the motor starts to run.

The running process is as follows:

The servo motor directly searches for the falling edge of the forward limit switch signal in reverse direction at low speed of $-(H05-33)$.

After reaching the falling edge of the forward limit switch signal, the motor decelerates and changes to forward direction, and searches for the rising edge of the forward limit switch signal at low speed of H05-33.

During forward acceleration or forward constant speed running, the motor stops immediately after reaching the rising edge of the forward limit switch signal.

Figure 5-54 Motor running curve 2 and speeds in Mode 6

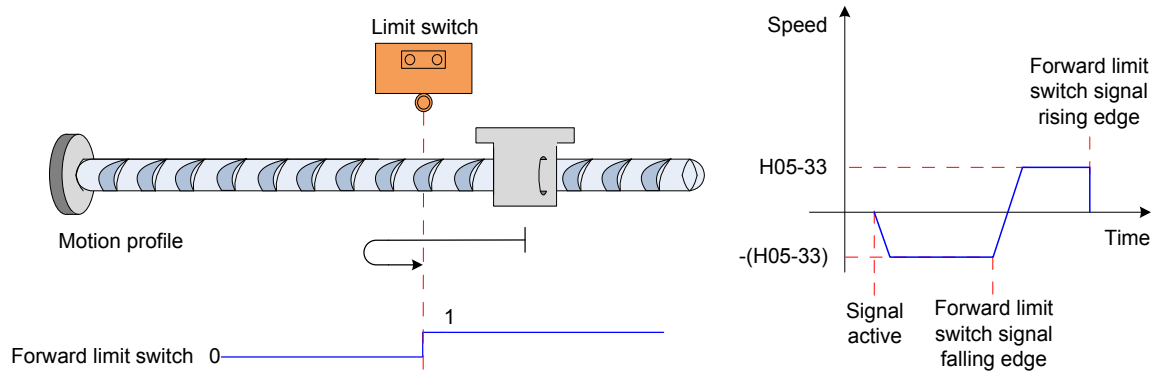

e. H05-31 = 8: Forward direction, deceleration point being forward limit switch signal and home being motor Z signal

- The forward limit signal is inactive (0: inactive, 1: active) when the motor starts to run.

The running process is as follows:

The servo motor searches for the forward limit switch signal in forward direction at high speed of H05-32.

After reaching the rising edge of the forward limit switch signal, the motor then decelerates and changes to reverse direction according to the time set in H05-34, and searches for the falling edge of the forward limit switch signal at low speed of $-(H05-33)$.

After reaching the falling edge of the forward limit switch signal, the motor decelerates and restores to forward direction, and searches for the rising edge of the forward limit switch signal at low speed of H05-33.

After reaching the rising edge of the forward limit switch signal, the motor continues to run and stops immediately after reaching Z signal for the first time.

5

Figure 5-55 Motor running curve 1 and speeds in Mode 8

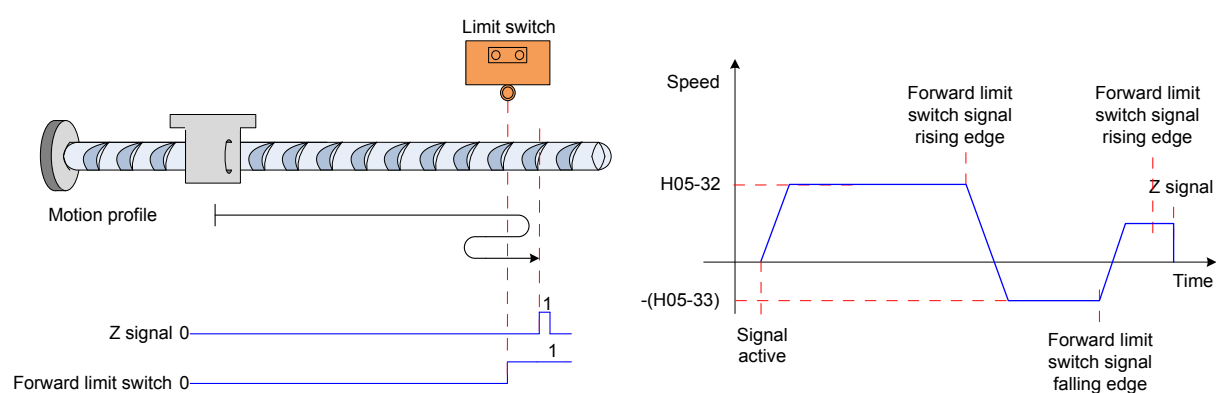

- The forward limit switch signal is active when the motor starts to run.

The running process is as follows:

The servo motor directly searches for the falling edge of the forward limit switch signal in reverse direction at low speed of $-(H05-33)$.

After reaching the falling edge of the forward limit switch signal, the motor decelerates and changes to forward direction, and searches for the rising edge of the forward limit switch signal at low speed of H05-33.

After reaching the rising edge of the forward limit switch signal, the motor continues to run in forward direction at low speed of H05-33, and stops immediately after reaching Z signal for the first time.

Figure 5-56 Motor running curve 2 and speeds in Mode 8

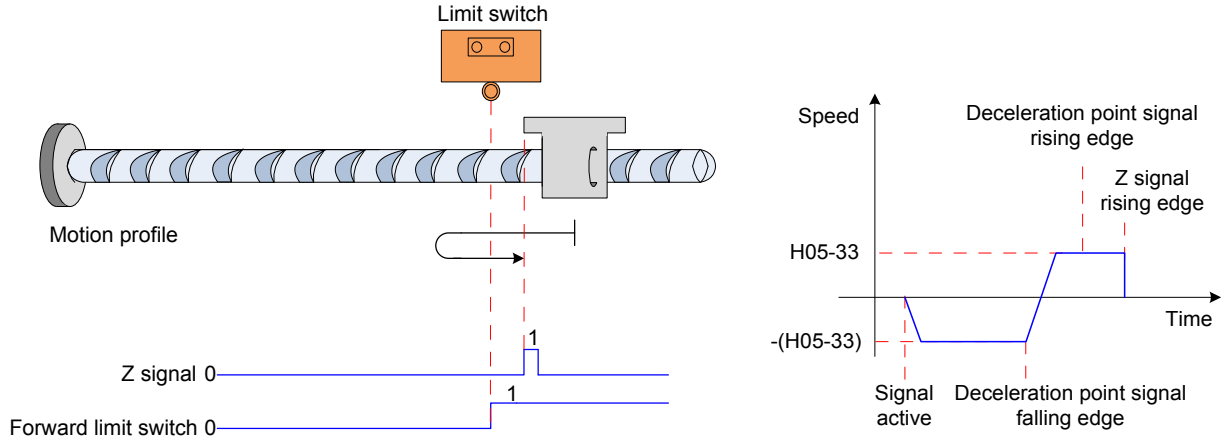

3) Electric home attaining: Start electrical home attaining (H05-30 = 5)

After homing attaining is completed, the mechanical zero position of the servo system is obtained. H05-36 sets the distance for the servo motor to move from the current absolute position (H0B-07) to the specified position (H05-36). In the electric home attaining mode, the servo motor keeps running at high speed of H05-32. The total motor displacement is determined by the difference between H05-36 and H0B-07, and the running direction is determined by position/negative of the total motor displacement.

After completing the displacement reference, the motor stops immediately.

Figure 5-57 Motor running curve and speed of electric homing attaining

5

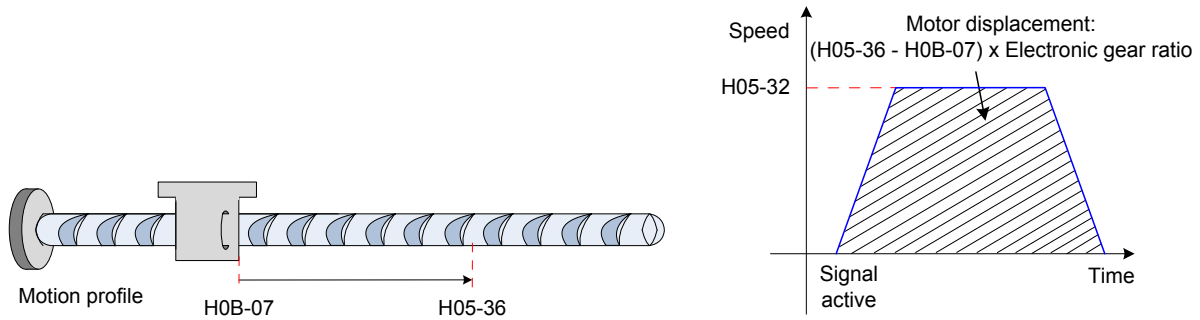

4) Mechanical home reference point and mechanical zero

The following table takes H05-30 = 0 as an example to describe the difference between mechanical home reference point and mechanical zero.

Table 5-20 Difference between mechanical home reference point and mechanical zero

Mechanical Zero Different From Mechanical Home Reference Point	Mechanical Zero Same As Mechanical Home Reference Point
<p>If the home offset is set (H05-36 ≠ 0) and the mechanical zero is different from the mechanical home reference point (H05-40 = 0 or 2), the motor stops immediately after reaching the rising edge of the home signal during forward acceleration or forward constant speed running, and the motor absolute position (H0B-07) is forced to H05-36.</p>	<p>If the home offset is set (H05-36 ≠ 0) and the mechanical zero is the same as the mechanical home reference point (H05-40 = 1 or 3), the motor continues to run after reaching the rising edge of the home switch signal during forward acceleration or forward constant speed running until the motor absolute position (H0B-07) = H05-36.</p>

5) Parameter setting

a. Setting of homing mode

Relevant parameters:

Function Code	Parameter Name	Setting Range	Function	Property	Effective Time	Default
H05-30	Homing enabling method	0: Disabled 1: Input HomingStart signal from DI to enable homing 2: Input HomingStart signal from DI to enable electrical home attaining 3: Start homing immediately upon power-on 4: Perform homing immediately 5: Start electrical home attaining 6: Take current position as the home	Set the method of enabling the homing function.	During running	Immediate	0

Function Code	Parameter Name	Setting Range	Function	Property	Effective Time	Default
H05-31	Homing mode	0: Forward direction, deceleration point and home being home switch signal 1: Reverse direction, deceleration point and home being home switch signal 2: Forward direction, deceleration point and home being motor Z signal 3: Reverse direction, deceleration point and home being motor Z signal 4: Forward direction, deceleration point being home switch signal and home being motor Z signal 5: Reverse direction, deceleration point being home switch signal and home being motor Z signal 6: Forward direction, deceleration point and home being forward limit switch signal 7: Reverse direction, deceleration point and home being reverse limit switch signal 8: Forward direction, deceleration point being forward limit switch signal and home being motor Z signal 9: Reverse direction, deceleration point being reverse limit switch signal and home being motor Z signal	Set the default motor rotating direction, deceleration point and home for home attaining	At stop	Immediate	0
H05-40	Mechanical home offset and action after reaching limit switch	0: H05-36 as coordinate for homing, trigger homing and find home reversely after reaching limit switch 1: H05-36 as relative offset for homing, trigger homing and find home reversely after reaching limit switch 2: H05-36 as coordinate for homing, automatically find zero reversely after reaching limit switch 3: H05-36 as relative offset for homing, automatically find position reversely after reaching limit switch	Set the offset of mechanical home reference point and mechanical zero and action after reaching limit switch during the homing operation.	At stop	Immediate	0

b. Setting of running curve

If the home switch signal is turned on after the deceleration signal becomes active but deceleration is insufficient, the positioning may be inaccurate. Fully consider the displacement required for deceleration when setting:

- Deceleration point/Home switch signal input position
- Acceleration/Deceleration time for home searching (H05-34)

Relevant parameters:

Function Code	Parameter Name	Setting Range	Unit	Function	Property	Effective Time	Default
H05-32	Low speed of homing	0 to 3000	RPM	Set the high speed value of searching for the deceleration point signal during home attaining. During electric home attaining, the motor runs always at the speed of H05-32.	At stop	Immediate	100
H05-33	High speed of homing	0 to 1000	RPM	Set the low speed value of searching for the deceleration point signal during home attaining. The value must be low enough to prevent mechanical impact at stop.	At stop	Immediate	10
H05-34	Acceleration/Deceleration time of homing	0 to 1000	ms	Set the time for the motor to change from 0 to 1000 RPM during the homing operation.	At stop	Immediate	1000
H05-35	Duration limit of homing	0 to 65535	ms	Set the time limit of the homing operation. If the time is exceeded, Er.601 will occur.	At stop	Immediate	10000
H05-36	Mechanical home offset	-1073741824 to 1073741824	Reference unit	Set the motor absolute position value (H0B-07) after homing.	At stop	Immediate	0

Relevant function No.:

No.	Function Symbol	Function Name	Description												
FunIN.31	HomeSwitch	Home switch	Valid: current position being home <table border="1"> <thead> <tr> <th>Logic of DI with HomeSwitch</th> <th>Actual Valid Level</th> </tr> </thead> <tbody> <tr> <td>0 (low level)</td> <td>Low level</td> </tr> <tr> <td>1 (high level)</td> <td>High level</td> </tr> <tr> <td>3 (rising edge)</td> <td>High level</td> </tr> <tr> <td>4 (falling edge)</td> <td>Low level</td> </tr> <tr> <td>5 (edge change)</td> <td>Low level</td> </tr> </tbody> </table> Set the logic of the DI terminal with this function to high/low level valid according to the output of the host controller.	Logic of DI with HomeSwitch	Actual Valid Level	0 (low level)	Low level	1 (high level)	High level	3 (rising edge)	High level	4 (falling edge)	Low level	5 (edge change)	Low level
Logic of DI with HomeSwitch	Actual Valid Level														
0 (low level)	Low level														
1 (high level)	High level														
3 (rising edge)	High level														
4 (falling edge)	Low level														
5 (edge change)	Low level														
FunIN.32	HomingStart	Homing function	Valid: Enabled (the function cannot be enabled repeatedly when running) Invalid: Disabled												
FunOUT.16	HomeAttain	Home attaining output	Valid: Home attaining completed in position control mode Invalid: Home attaining not completed												
FunOUT.17	ElecHomeAttain	Electrical home attaining output	Valid: Electrical home attaining completed in position control mode Invalid: Electrical home attaining not completed												

c. Working time sequence

5

H05-30 = 1 or 2

Figure 5-58 Example of time sequence diagram

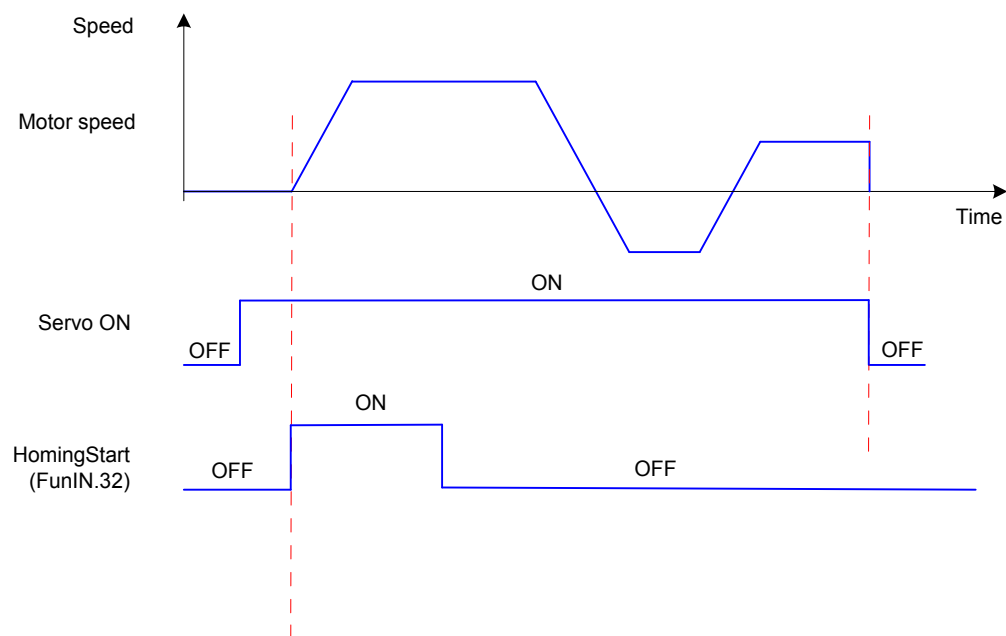

Turn on the S-ON signal and then HomingStart signal.

During the homing operation, the S-ON signal remains active and the HomingStart signal change is shielded.

During the homing operation, the servo motor stops if the S-ON signal is turned off. To enable the homing function again, turn on the S-ON signal and then HomingStart signal.

If Er.601 indicating homing timeout occurs, the servo motor stops, and the S-ON signal remains active. After the HomingStart signal is turned on again, and Er601 is reset and the homing operation is carried out again.

The homing operation can be triggered repeatedly.

- H05-30 = 3

The homing operation is carried out only when the S-ON signal is turned on for the first time after power-on.

The servo motor stops when Er.601 occurs. Er601 can be reset after the S-ON signal is turned off.

The homing operation cannot be triggered repeatedly after power-on again.

- H05-30 = 4 or 5

The homing operation is carried out immediately if the S-ON signal is turned on after power-on.

During the homing operation, the servo motor stops if the S-ON signal is turned off. The homing function is enabled again if the S-ON signal is turned on again.

When Er.601 occurs, H05-30 becomes 0 and the servo motor stops. Er601 can be reset after the S-ON signal is turned off. To enable the homing function again, re-set H05-30. After the homing operation is completed, H05-30 becomes 0. To enable the homing function again, re-set H05-30.

- H05-30 = 6

When using the current position as the home and home offset (H05-40 = 0 or 2, H05-36 ≠ 0) is required, set H05-36 and H05-40 first, and then set H05-30 to 6. Otherwise, H0B-07 is the value before H05-36 is modified.

After the homing operation is completed, H05-30 becomes 0. To enable the homing function again, re-set H05-36 and set H05-30 to 6.

5.2.9 Function Code Block Diagram

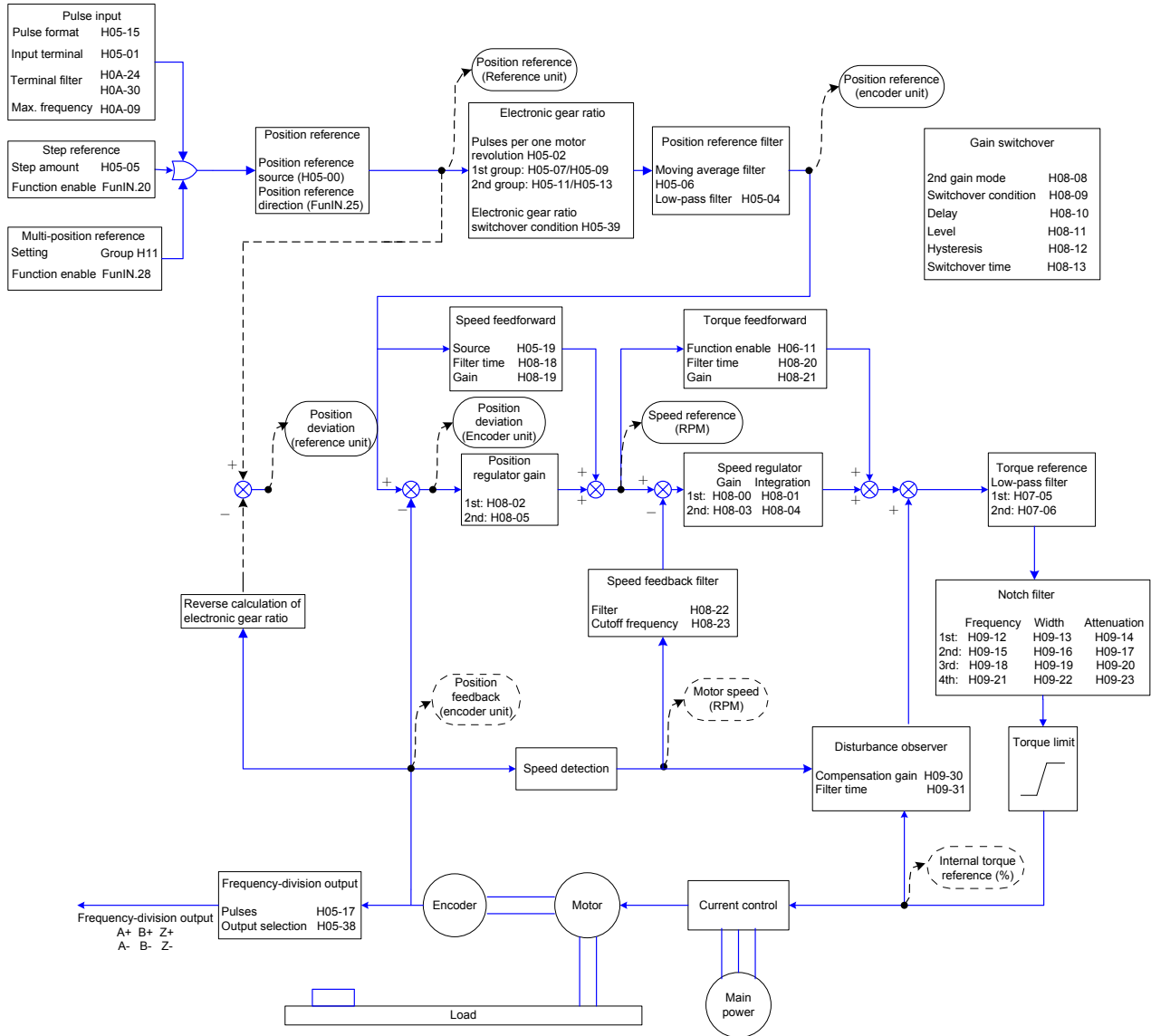

5

5.3 Speed Control Mode

Figure 5-59 Block diagram of the speed control mode

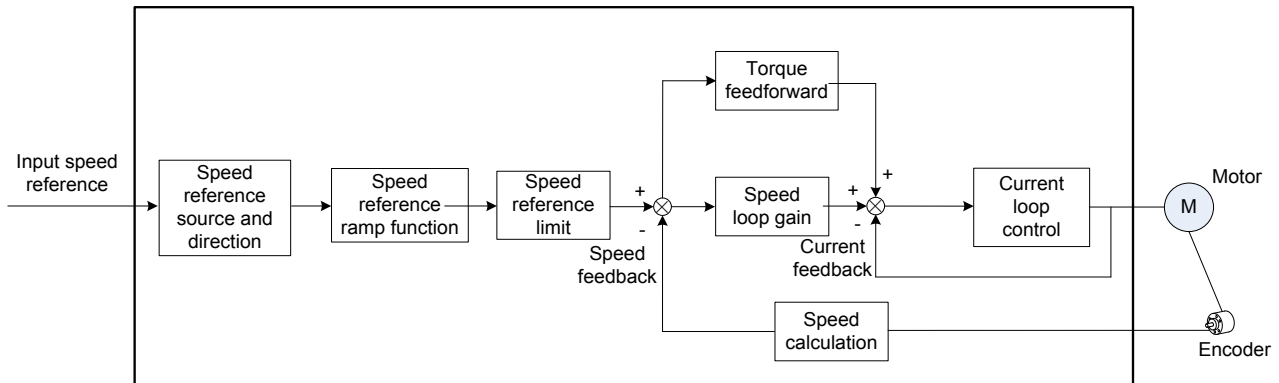

Set H02-00 to 0 on the keypad or Inovance servo commissioning software to enable the speed control mode.

Set the servo drive parameters based on the mechanical structure and specifications. The following part uses the basic parameter setting to describe the speed control mode.

Figure 5-60 Signal exchange between the servo drive and the host controller

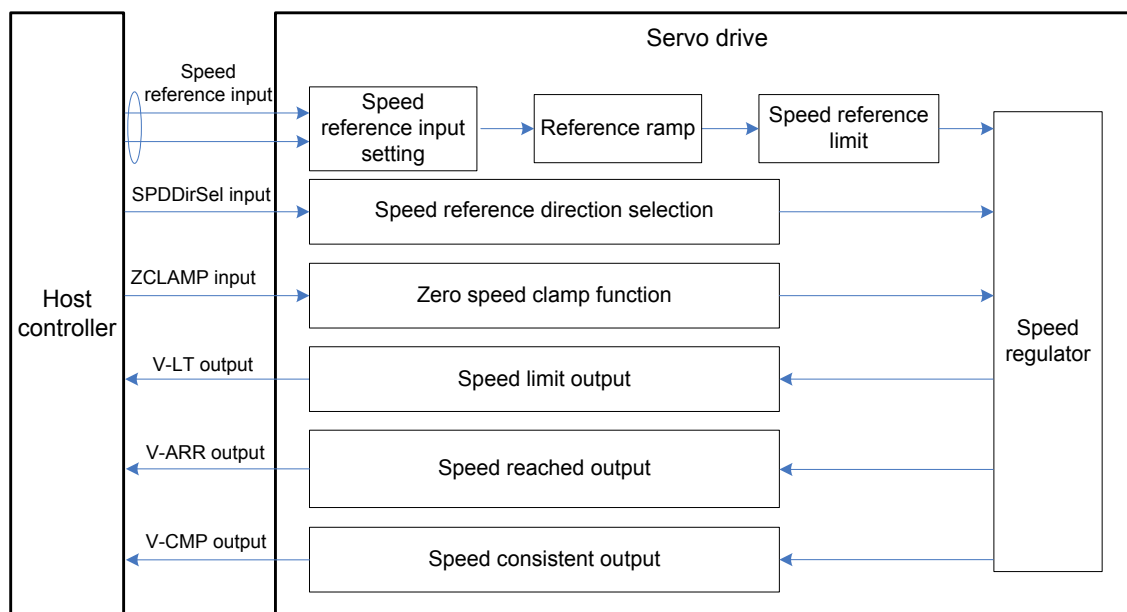

5.3.1 Speed Reference Input Setting

1). Speed reference source

In the speed control mode, five methods of obtaining speed references are available, and you can select one in H06-02.

Figure 5-61 Speed reference source selection

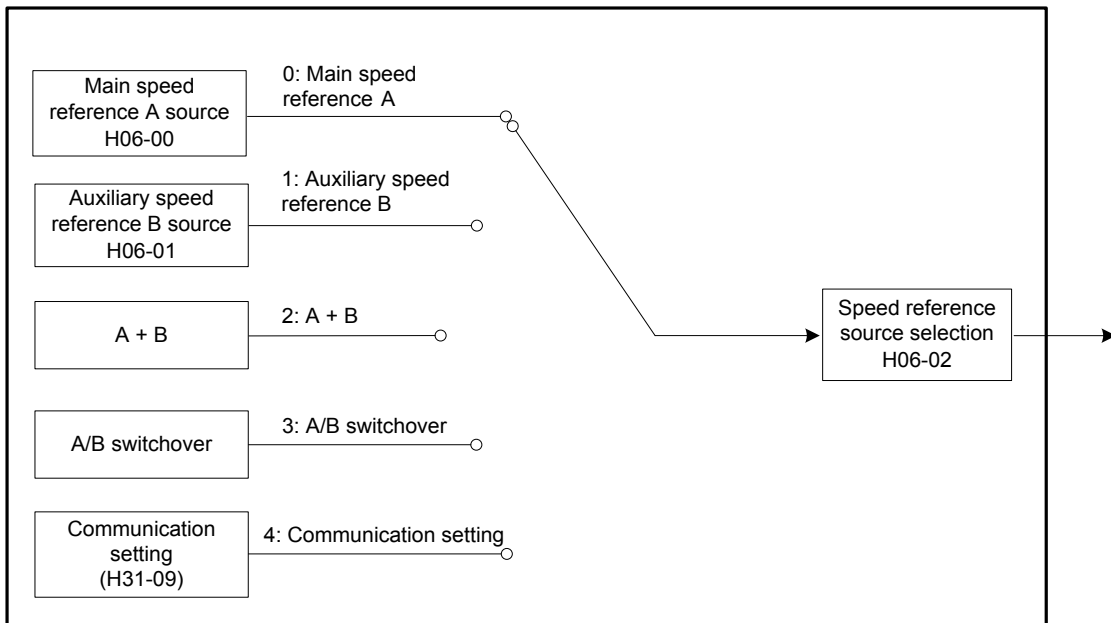

Relevant parameters:

Function Code	Parameter Name	Setting Range	Unit	Function	Property	Effective Time	Default
H06-02	Speed reference source selection	0: Main speed reference A source 1: Auxiliary speed reference B source 2: A + B 3: A/B switchover 4: Communication setting	-	Select the speed reference source.	At stop	Immediate	0

5

a. Main speed reference A source

The main speed reference A sources include digital setting and analog voltage setting. Digital setting produces the internal speed reference, and the analog voltage setting produces the external speed reference.

Figure 5-62 Main speed reference A source

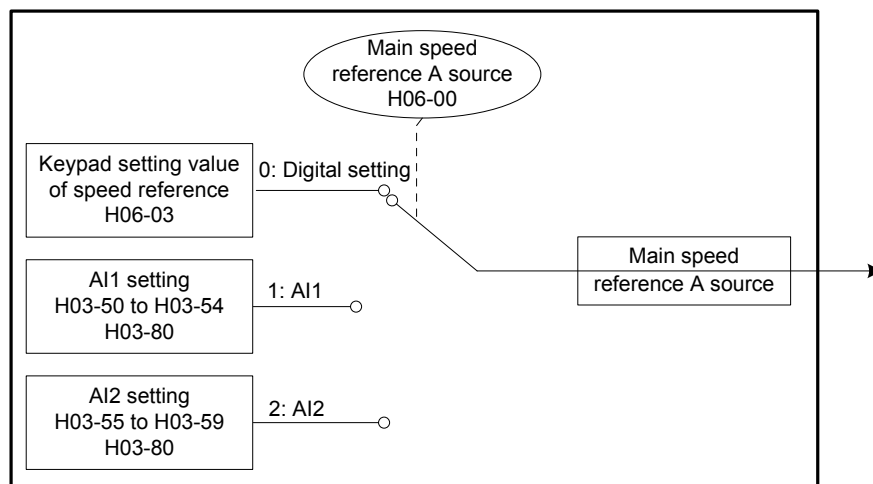

Relevant parameters:

Function Code	Parameter Name	Setting Range	Unit	Function	Property	Effective Time	Default
H06-00	Main speed reference A source	0: Digital setting (H06-03) 1: AI1 2: AI2	-	Select the source of main speed reference A.	At stop	Immediate	0

- Digital setting

The speed reference is set in H06-03.

Relevant parameters:

Function Code	Parameter Name	Setting Range	Unit	Function	Property	Effective Time	Default
H06-03	Keypad setting value of speed reference	-6000 to 6000	RPM	Set the value of the internal speed reference, in unit of 1 RPM.	During running	Immediate	200

- Analog voltage setting

The analog voltage signal output by the host controller or other devices is processed and then used as the speed reference.

Analog voltage input terminal:

The servo drive provides two analog input channels, AI1 and AI2, with maximum input voltage ± 10 VDC, input impedance 9 k Ω .

Analog input circuit:

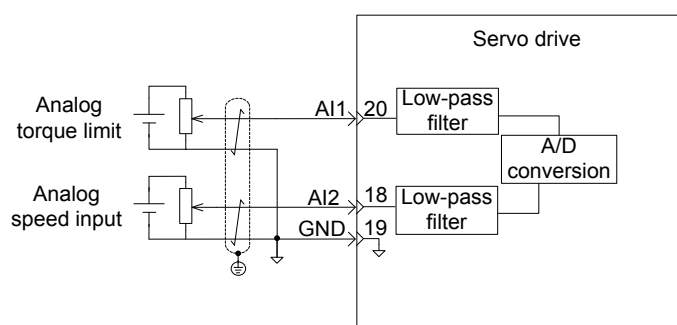

Operation method:

The following figure takes AI2 as an example to describe the analog setting of the speed reference.

Figure 5-63 Operation flowchart of setting speed reference by analog voltage

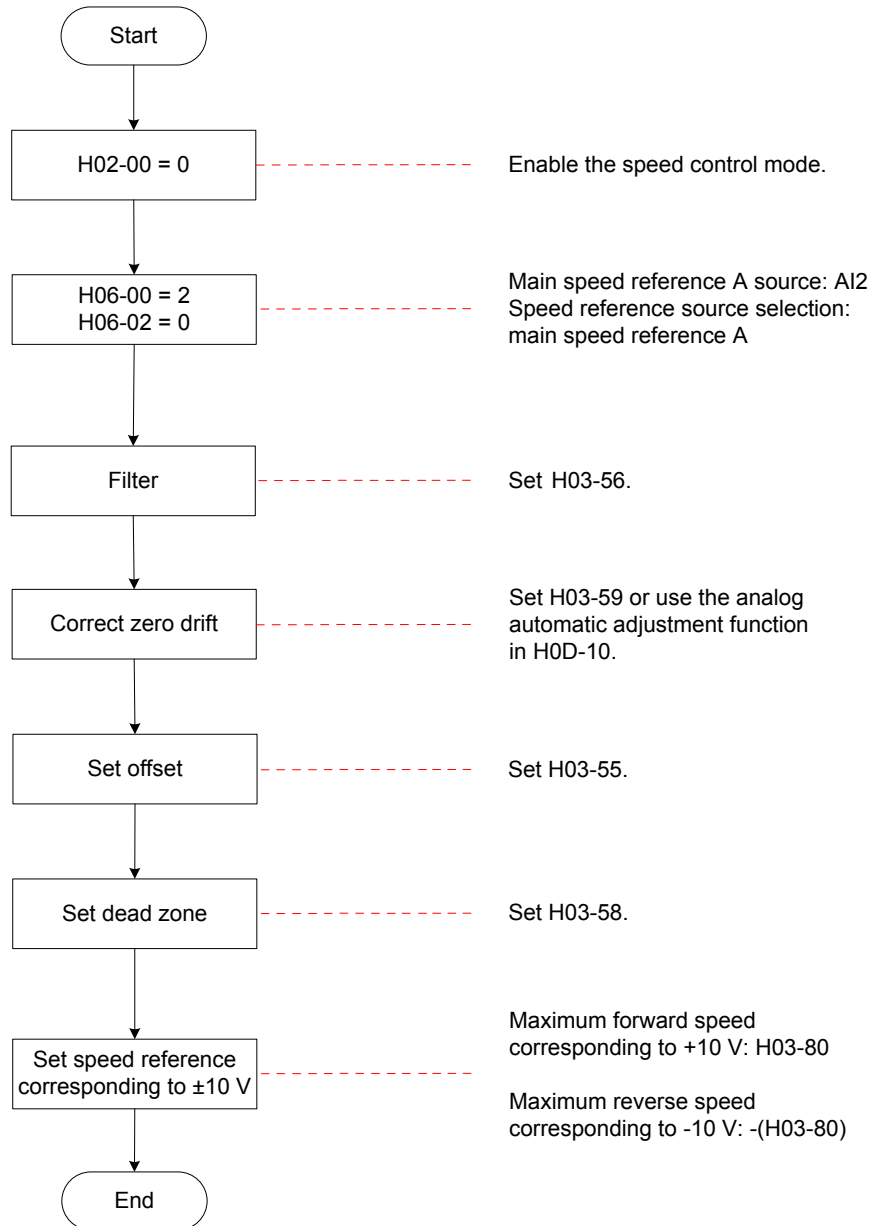

5

Zero drift: value of the servo drive sampling voltage relative to GND when the input voltage of the analog channel is zero

Offset: input voltage value of the analog channel when the sampling voltage is zero after zero drift correction

Dead zone: input voltage range of the analog channel when the sampling voltage is zero

In the following figure, y_1 is the output voltage of the analog channel not processed, and y_6 is the final speed reference.

Figure 5-64 AI processing of servo drive

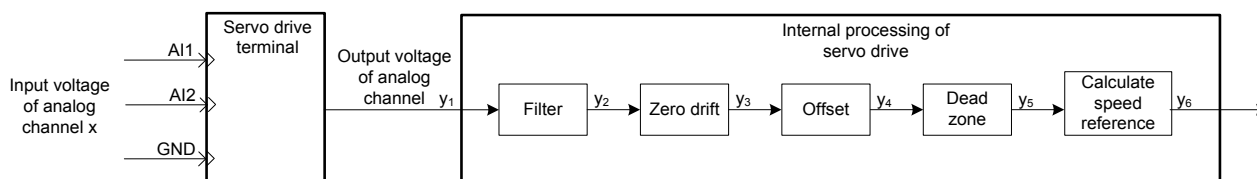
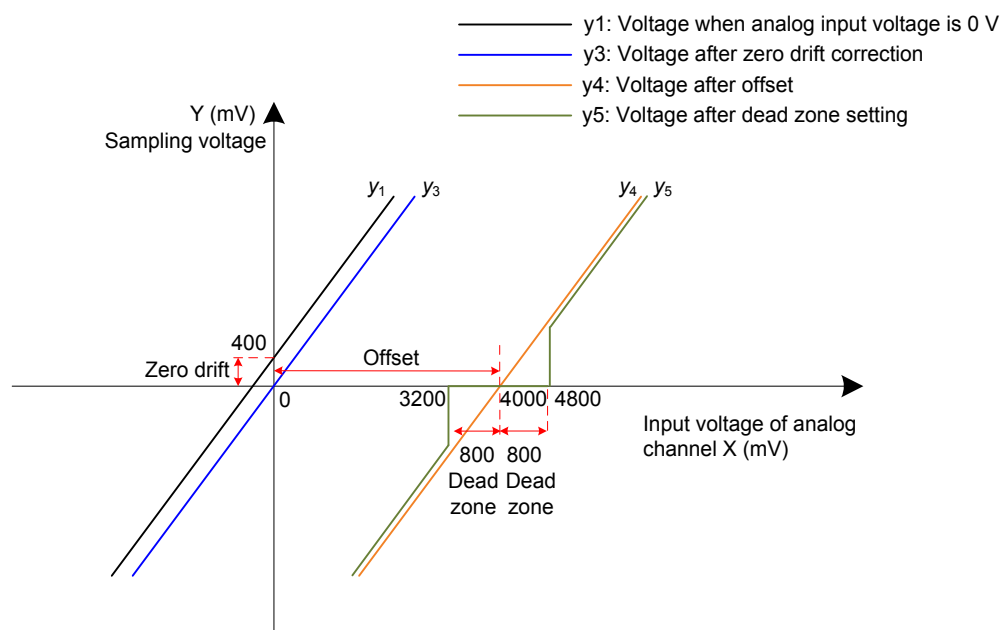

Figure 5-65 Example of sampling voltage and servo drive AI processing



- Filter:

The servo drive provides the analog channel filter function. Setting the filter time constant in H03-56 prevents motor reference fluctuation due to instable analog input voltage and eliminates motor malfunction due to signal interference. The filter function cannot eliminate or suppress the zero drift or dead zone.

- Zero drift correction:

It corrects the analog output voltage offset relative to the output for the actual input voltage 0 V.

In the preceding figure, the analog output voltage without being processed by the servo drive is shown as y_1 . Take the filter time constant $H03-56 = 0.00$ ms as an example, and the sampling voltage after filter $y_2 = y_1$.

That is, when the actual input voltage $x = 0$, the output voltage $y_1 = 400$ mV. Therefore, the zero drift voltage is 400 mV.

Set H03-59 to 400.0 (mV). The sampling voltage after zero drift correction is shown as y_3 .

$$y_3 = y_1 - 400.0$$

Zero drift correction can also be carried out by using the analog automatic adjustment function in H0D-10.

- Offset setting:

It sets the actual input voltage corresponding to sampling voltage 0.

Assume that the actual input voltage $x = 4000$ mV when the sampling voltage $y_3 = 0$. That is, the offset is 4000 mV.

Set H03-55 to 4000 (mV). The sampling voltage after offset $y_4 = x - 4000 = y_3 - 4000$

- Dead zone correction:

It sets the effective input voltage range when the sampling voltage of the servo drive is not 0.

After the offset is set, if the sampling voltage is always 0 when the input voltage x is within 3200 mV

to 4800 mV, the dead zone is 800 mV.

Set H03-58 to 800.0 (mV). The sampling voltage after dead zone correction is shown as y_5 :

$$y_5 = \begin{cases} 0 & 3200 \leq x \leq 4800 \\ y_4 & 4800 < x \leq 10000 \text{ or } -10000 \leq x < 3200 \end{cases}$$

Speed reference calculation:

After setting the zero drift, offset, and dead zone, set the speed reference corresponding to 10 V (10000 mV) in H03-80 to obtain the actual speed reference y_6 :

$$y_6 = \frac{y_5}{10000} \times (\text{H03-80})$$

This value is used as the speed reference set via analog in the speed control mode.

The following figures show the relationship between analog input and speed values respectively when the offset is absent and present. After all setting is completed correctly, view the sampling voltage of AI2 in H0B-22 or the speed reference corresponding to analog input in H0B-01.

Figure 5-66 No-offset AI2

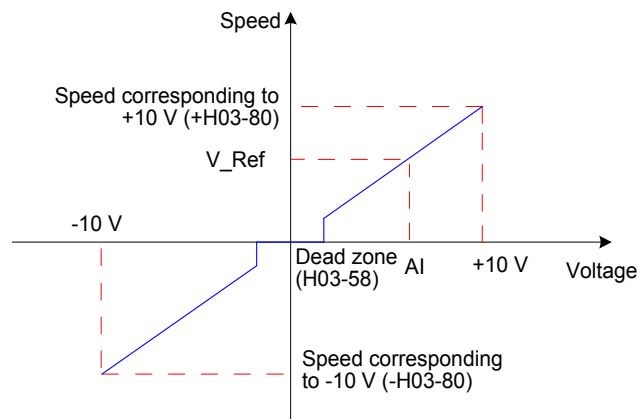

5

Figure 5-67 After-offset AI2

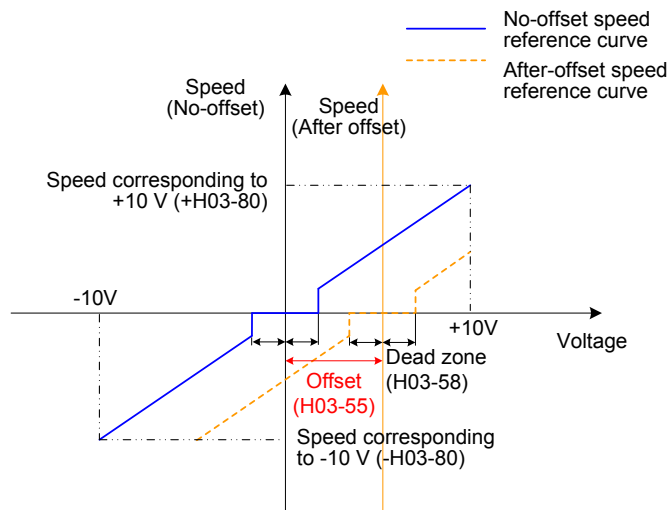

The relationship between the final speed reference y_6 and the input voltage x is:

$$y_6 = \begin{cases} 0 & B - C \leq x \leq B + C \\ x - B & B + C < x \leq 10000 \text{ or } -10000 \leq x < B - C \end{cases}$$

B: offset, C: dead zone

Relevant parameters:

Function Code	Parameter Name	Setting Range	Unit	Function	Property	Effective Time	Default
H03-55	AI2 offset	-5000 to 5000	mV	Set the offset of the analog channel AI2.	During running	Immediate	0
H03-56	AI2 filter time constant	0 to 655.35	ms	Set the moving average filter time constant of the analog channel AI2.	During running	Immediate	2.00
H03-58	AI2 dead zone	0 to 1000.0	mV	Set the dead zone of the analog channel AI2.	During running	Immediate	10.0
H03-59	AI2 zero drift	-500.0 to 500.0	mV	Set the zero drift of the analog channel AI2.	During running	Immediate	0.0
H03-80	Speed corresponding to 10 V	0 to 6000	RPM	Set the speed corresponding to analog input 10 V.	At stop	Immediate	3000
H0D-10	Analog automatic adjustment	0: Disabled 1: AI1 adjustment 2: AI2 adjustment	-	Set whether to enable automatic zero drift correction of AI1 and AI2.	At stop	Immediate	0

Note

The setting method of AI1 is the same as that of AI2 described above. For the detailed parameter descriptions, refer to Chapter 7.

b. Auxiliary speed reference B source

The auxiliary speed reference B sources include digital setting, analog setting, and multi-speed references. Digital setting and multi-speed references produce the internal speed reference, and analog setting produces the external speed reference.

5

Figure 5-68 Auxiliary speed reference B source

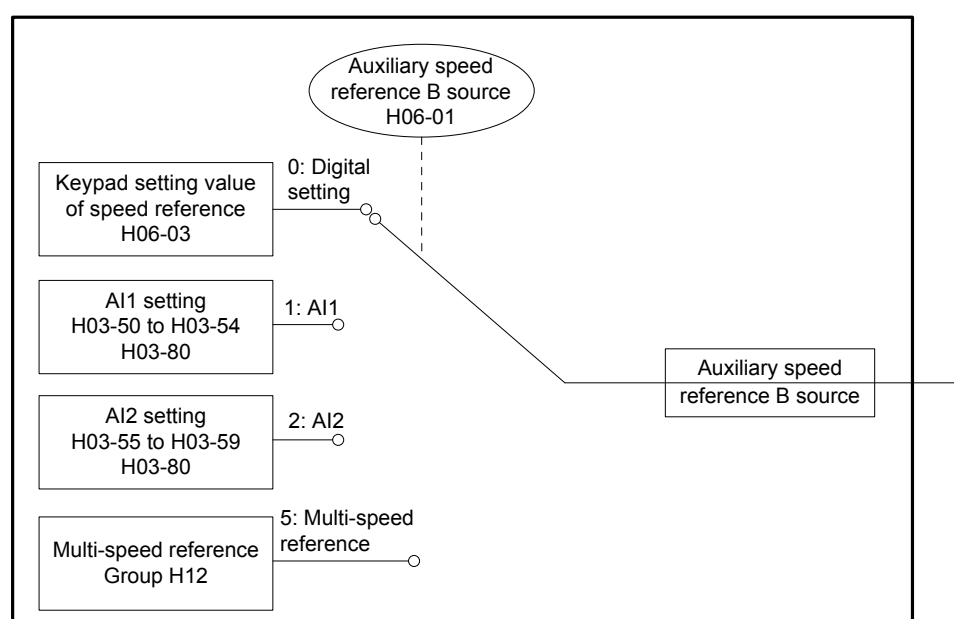

Relevant parameters:

Function Code	Parameter Name	Setting Range	Unit	Function	Property	Effective Time	Default
H06-01	Auxiliary speed reference B source	0: Digital setting (H06-03) 1: AI1 2: AI2 3: 0 (Invalid) 4: 0 (Invalid) 5: Multi-speed reference	-	Set the source of auxiliary speed reference B	At stop	Immediate	1

Digital setting and analog setting are the same as those of main speed reference A source. The following part describes how to set auxiliary speed reference B via multi-speed reference.

The servo drive stores 16 speed references, and the maximum running speed and running time of each can be set. Four groups of acceleration/deceleration time are optional. The setting flowchart is shown in the following figure.

Figure 5-69 Multi-speed reference setting flowchart

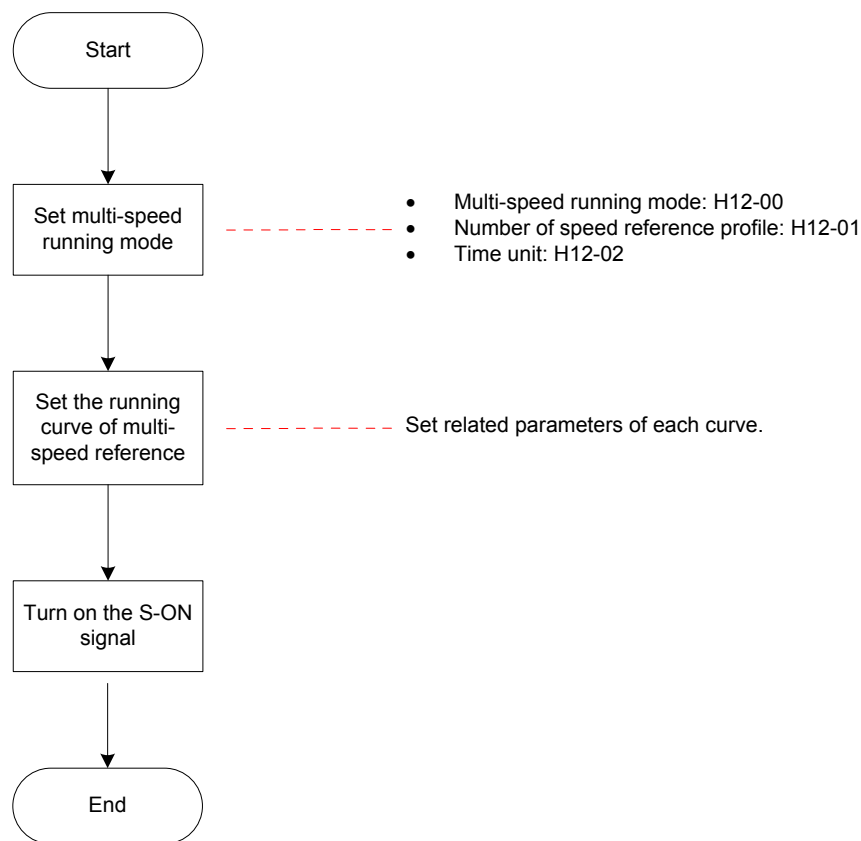

5

■ Setting of multi-speed running mode

Relevant parameters:

Function Code	Parameter Name	Setting Range	Unit	Function	Property	Effective Time	Default
H12-00	Multi-speed running mode	0: Stop after running single cycle (number of speeds set in H12-01) 1: Cyclic running (number of speeds set in H12-01) 2: DI switchover	-	Set the multi-speed running mode.	At stop	Immediate	1
H12-01	Number of speed reference profile	1 to 16	-	Set the total number of speed references.	At stop	Immediate	1
H12-02	Time unit	0: Sec 1: Min		Set the time unit of multi-speed running.	During running	Immediate	1

Set an external DI terminal with FunIN.5: DIR-SEL to select the multi-speed running direction.

Relevant function No.:

No.	Function Symbol	Function Name	Description
FunIN.5	DIR-SEL	Multi-reference direction	Invalid: Default reference direction Valid: Reverse to reference direction

The following part takes H12-01 = 2 as an example to describe each running mode.

Stop after running single cycle (H12-00 = 0)

Set H12-00 to 0 to select the running mode of stop after running single cycle. Set H12-01 and H12-02 based on the total number of speeds and running time unit, and set each speed reference, running time, and acceleration/deceleration. The servo drive runs from 1st speed to Nth speed and stops after completing the end speed.

Table 5-21 Description of stop after running single cycle

Mode Description	Running Curve
<p>The servo drive stops at one-cycle running.</p> <p>The servo drive automatically switches to the next speed with a larger No.</p>	<div data-bbox="777 611 1281 876" style="text-align: center;"> </div> <p>V_{1max}, V_{2max}: 1st and 2nd speeds</p> <p>t_1: actual acceleration/deceleration time of 1st speed</p> <p>t_3, t_5: actual acceleration/deceleration time of 2nd speed</p> <p>Running time of a certain speed = Speed change time from previous speed reference switched over to the current speed reference + Average running time</p> <p>For example, the running time of the 1st speed and 2nd speed is respectively $t_1 + t_2$ and $t_3 + t_4$.</p> <p>Do not set the running time to 0; otherwise, the servo drive automatically ignores this speed reference and directly runs the next speed No.</p> <p>When the actual motor speed reaches the maximum running speed, the speed reached signal becomes active.</p> <p>If the S-ON signal becomes OFF during running of a certain speed, the servo motor stops according to the stop mode in H02-05.</p>

One-cycle running: The servo drive completes running the total number of speeds set in H02-01.

Cyclic running (H12-00 = 1)

Set H12-00 to 1 to select the cyclic running mode. Set H12-01 and H12-02 based on the total number of speeds and running time unit, and set each speed reference, running time, and acceleration/deceleration. The servo drive runs from 1st speed to Nth speed and automatically starts from 1st speed again after completing one cycle.

Table 5-22 Descriptions of cyclic running

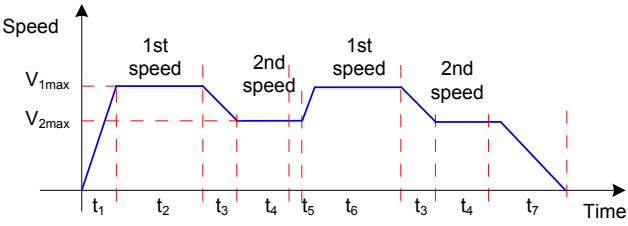
Mode Description	Running Curve
<p>The servo drive repeats from the 1st speed after each cycle of running.</p> <p>The servo drive automatically switches to the next speed with a larger No.</p> <p>The cyclic running state remains if the S-ON signal is active.</p>	 <p>V_{1max}, V_{2max}: maximum values of 1st and 2nd speeds</p> <p>Running time of a certain speed = Speed change time from previous speed reference switched over to the current speed reference + Average running time</p> <p>For example, the running time of the 1st speed and 2nd speed is respectively $t_1 + t_2$ and $t_3 + t_4$.</p> <p>Do not set the running time to 0; otherwise, the servo drive automatically ignores this speed reference and directly runs the next speed No.</p> <p>When the actual motor speed reaches the maximum running speed, the speed reached signal becomes active.</p> <p>If the S-ON signal becomes OFF during running of a certain speed, the servo motor stops according to the stop mode in H02-05.</p>

DI switchover (H12-00 = 2)

Set H12-00 to 2 to select the running mode of DI switchover. Set H12-01 and H12-02 based on the total number of speeds and running time unit, and set each speed reference, running time, and acceleration/deceleration. The servo drive selects the speed No. based on the state combinations of the external DI terminals (CMDx).

Table 5-23 Descriptions of DI switchover

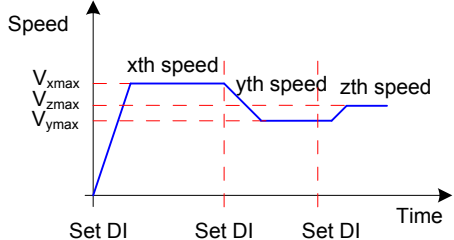
Mode Description	Running Curve
<p>The servo drive continues running when the S-ON signal is active.</p> <p>The speed No. is determined by the DI terminal logic.</p> <p>The running time of each speed reference is determined by the time interval for speed No. switchover.</p>	 <p>x, y: speed No; for the relationship between the speed No. and the DI terminal logic, see the descriptions below.</p> <p>If the speed No. determined by the DI does not change, the servo drive continues running at this speed, without being affected by the running time.</p> <p>When the actual motor speed reaches the maximum running speed, the speed reached signal becomes active.</p> <p>If the S-ON signal becomes OFF during running of a certain speed, the servo motor stops according to the stop mode in H02-05.</p>

When the multi-speed running mode is DI switchover, set four DI terminals with functions 6 to 9 (FunIN.6:CMD1 to FunIN.9:CMD4, multi-reference switchover) and set the terminal logic. In addition, set a DI terminal with function 5 (FunIN.5:DIR-SEL, multi-reference direction) for switching over the speed reference direction.

5

Ensure that the S-ON signal is active during running of each speed. Otherwise, the servo drive immediately stops according to the stop mode set in H02-05.

The speed reached signal (FunOUT.19:V-Arr) is active when a certain speed reference is reached.

Relevant function No.:

No.	Function Symbol	Function Name	Description
FunIN.5	DIR-SEL	Multi-reference direction	<p>Used to switch over the speed reference direction in multi-speed DI switchover mode.</p> <p>Invalid: Default reference direction</p> <p>Valid: Reverse to reference direction</p>

No.	Function Symbol	Function Name	Description																									
FunIN.6	CMD1	Multi-reference switchover 1	The speed No. is a 4-bit binary value, and the relationship between CMD1 to CMD4 and the speed No. is listed in the following table. <table border="1" style="margin: 10px auto;"> <thead> <tr> <th>CMD4</th> <th>CMD3</th> <th>CMD2</th> <th>CMD1</th> <th>Speed No.</th> </tr> </thead> <tbody> <tr> <td>0</td> <td>0</td> <td>0</td> <td>0</td> <td>1</td> </tr> <tr> <td>0</td> <td>0</td> <td>0</td> <td>1</td> <td>2</td> </tr> <tr> <td colspan="5" style="text-align: center;">...</td> </tr> <tr> <td>1</td> <td>1</td> <td>1</td> <td>1</td> <td>16</td> </tr> </tbody> </table> CMD(n) is 1 when the DI terminal logic is valid and 0 when the DI terminal logic is invalid.	CMD4	CMD3	CMD2	CMD1	Speed No.	0	0	0	0	1	0	0	0	1	2	...					1	1	1	1	16
CMD4	CMD3	CMD2		CMD1	Speed No.																							
0	0	0		0	1																							
0	0	0		1	2																							
...																												
1	1	1	1	16																								
FunIN.7	CMD2	Multi-reference switchover 2																										
FunIN.8	CMD3	Multi-reference switchover 3																										
FunIN.9	CMD4	Multi-reference switchover 4																										

Figure 5-70 Example of multi-speed curve and DI signal states

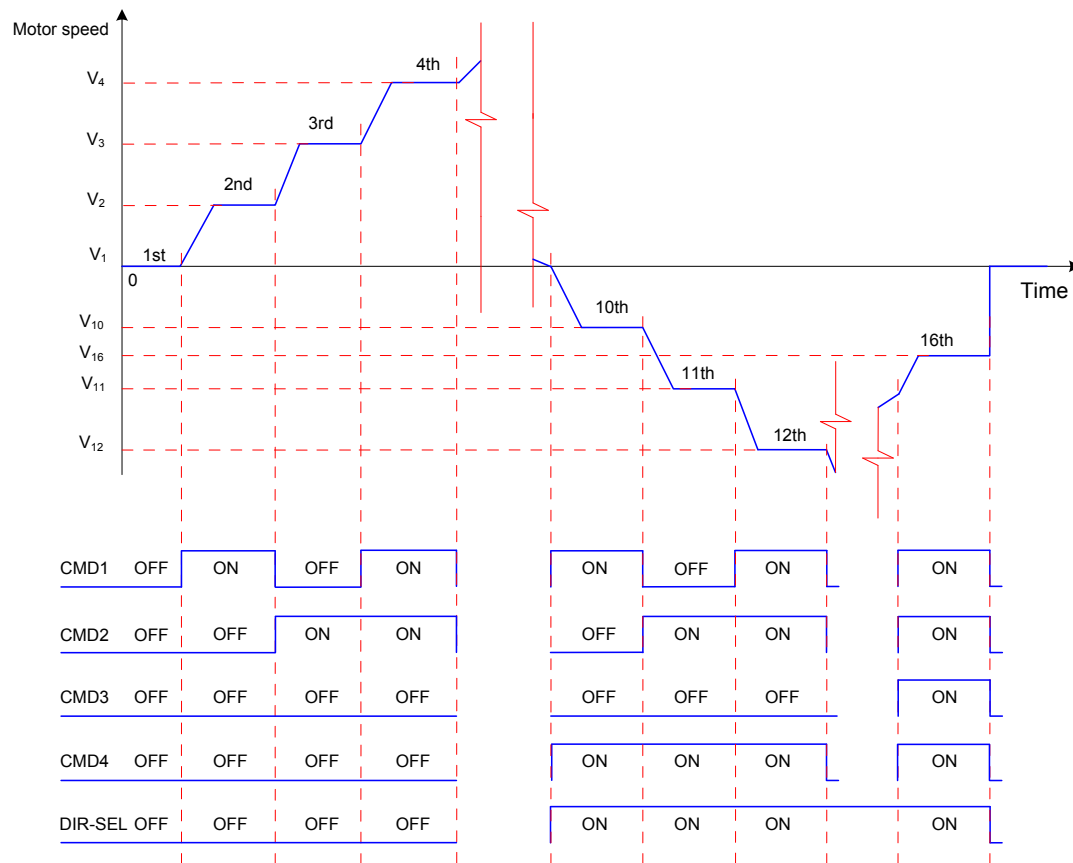

■ Setting of multi-speed running curve

The following part takes the 1st speed reference as an example to describe the running curve.

Relevant parameters:

Function Code	Parameter Name	Setting Range	Unit	Function	Property	Effective Time	Default
H12-03	Acceleration time 1	0 to 65535	ms	Set the 1st group of acceleration/ deceleration time.	At stop	Immediate	10
H12-04	Deceleration time1	0 to 65535	ms		At stop	Immediate	10

Function Code	Parameter Name	Setting Range	Unit	Function	Property	Effective Time	Default
H12-09	Acceleration time 4	0 to 65535	ms	Set the 1th group of acceleration/ deceleration time.	At stop	Immediate	150
H12-10	Deceleration time4	0 to 65535	ms		At stop	Immediate	150
H12-20	1st speed reference	-6000 to 6000	RPM	Set the value of the 1st speed reference.	At stop	Immediate	0
H12-21	Running time of 1st speed reference	0 to 6553.5	s (min)	Set the running time of the 1st speed reference.	At stop	Immediate	5.0
H12-22	Acceleration/ deceleration time of 1st speed reference	0: No acceleration/ deceleration time 1: Acceleration/ Deceleration time 1 2: Acceleration/ Deceleration time 2 3: Acceleration/ Deceleration time 3 4: Acceleration/ Deceleration time 4	-	Set the acceleration/ deceleration time of the 1st speed reference.	At stop	Immediate	0

Four groups of acceleration/deceleration time are optional. By default, no acceleration/deceleration time is used. The following part takes H12-01 = 1 to describe the actual acceleration/deceleration time and running time.

Figure 5-71 Example of curve of a certain speed in multi-speed reference

5

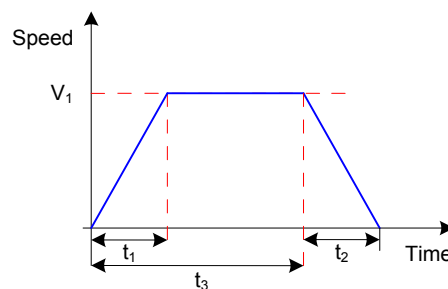

As shown in the preceding figure, the speed reference is V_1 , and actual acceleration time t_1 and deceleration time t_2 are:

$$t_1 = \frac{V_1}{1000} \times \text{Acceleration time of this speed reference}$$

$$t_2 = \frac{V_1}{1000} \times \text{Deceleration time of this speed reference}$$

Running time = Speed change time from previous speed reference switched over to the current speed reference + Average running time, t_3 in the preceding figure

c. A/B switchover

When H06-02 = 3 (A/B switchover), set a DI terminal with FunIN.4 (CMD-SEL, main/Auxiliary reference switchover). The signal of the DI terminal determines whether the main or auxiliary reference source is valid.

Relevant function No.:

No.	Function Symbol	Function Name	Description
FunIN.4	CMD-SEL	Main/Auxiliary reference switchover	Valid: Current running reference being A Invalid: Current running reference being B

d. Communication setting

When H06-02 = 4 (Communication setting), the speed reference is the value of H31-09, and H31-09 is not displayed on the keypad and can be set only via communication.

Relevant parameters:

Function Code	Parameter Name	Setting Range	Unit	Function	Property	Effective Time	Default
H31-09	Speed reference set via communication	-6000.000 to 6000.000	RPM	Set the speed reference (in unit of 0.001 RPM) when the speed reference source is communication setting in speed control mode.	During running	Immediate	-

2) Speed reference direction

A DI terminal with FunIN.26 (SPDDirSel, speed reference direction selection) is used to change the speed reference direction.

Relevant function No.:

No.	Function Symbol	Function Name	Description
FunIN.26	SPDDirSel	Speed reference direction selection	Valid: Forward direction Invalid: Reverse direction

The actual motor direction is related to the rotating direction in H02-02, positive/negative of speed reference, speed reference direction (FunIN.26).

Table 5-24 Actual motor rotating direction in speed control mode

H02-02	Positive/Negative of Speed Reference	FunIN.26	Actual Motor Rotating Direction
0	+	Invalid	Counterclockwise
0	+	Valid	Clockwise
0	-	Invalid	Clockwise
0	-	Valid	Counterclockwise
1	+	Invalid	Clockwise
1	+	Valid	Counterclockwise
1	-	Invalid	Counterclockwise
1	-	Valid	Clockwise

5.3.2 Ramp Function Setting

The ramp function converts the speed references with large acceleration rate to smoother speed reference, that is, it controls the acceleration rate by setting the acceleration/deceleration time.

A very large acceleration rate in speed control mode causes motor jitter or severe vibration. Increasing the acceleration/deceleration time smoothens the speed change and prevents mechanical damage.



When the speed reference source is digital setting, analog setting or jogging, the acceleration time and deceleration time are set in H06-05 and H06-06.

When the speed reference source is multi-speed reference, the acceleration/ deceleration time is set in group H12. For details, refer to Chapter 7.

Figure 5-72 Ramp control diagram

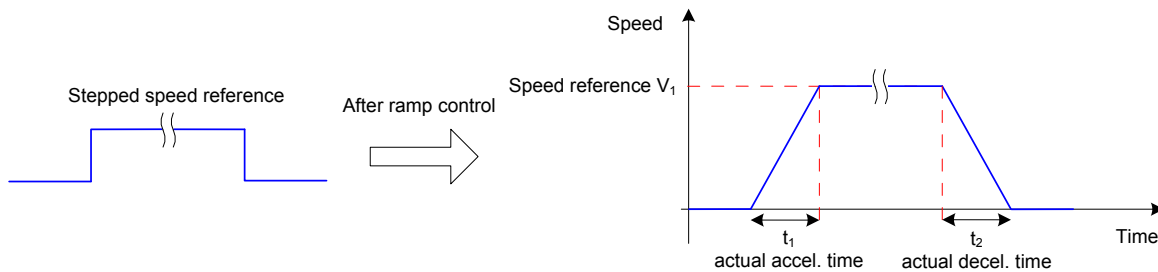

H06-05: time for the speed reference to accelerate from zero to 1000 RPM.

H06-06: time for the speed reference to decelerate from 1000 RPM to zero.

The formulas of calculating the actual acceleration and deceleration time are as follows:

$$\text{Actual acceleration time } t_1 = \frac{\text{Speed reference}}{1000} \times \text{Acceleration ramp time}$$

$$\text{Actual deceleration time } t_2 = \frac{\text{Speed reference}}{1000} \times \text{Deceleration ramp time}$$

5

Relevant parameters:

Function Code	Parameter Name	Setting Range	Unit	Function	Property	Effective Time	Default
H06-05	Acceleration ramp time constant of speed reference	0 to 65535	ms	Set the acceleration/ deceleration time of speed reference in speed control mode.	During running	Immediate	0
H06-06	Deceleration ramp time constant of speed reference	0 to 65535	ms		Immediate	During running	0

5.3.3 Zero Speed Clamp Function



The zero speed clamp function is used in the system in which the host controller does not construct the position loop in speed control mode.

If servo motor oscillation occurs in zero speed clamp state, adjust the position loop gain.

In speed control, if DI function FunIN.12 (ZCLAMP) is enabled, and the speed reference amplitude is smaller than or equal to the value of H06-15, the servo motor enters the zero speed clamp state.

At this moment, position loop is built inside the servo drive and speed reference is invalid. The servo motor is clamped within ± 1 pulse of the position at which zero speed clamp becomes valid. Even if it rotates due to external force, it will return to the zero position and be clamped.

When the speed reference amplitude is larger than the value of H06-15, the servo motor exits the zero speed clamp state and continues running according to the input speed reference. If the signal of the DI terminal with FunIN.12 (ZCLAMP) is inactive, the zero speed clamp function is disabled.

Figure 5-73 Zero speed clamp wiring and waveform

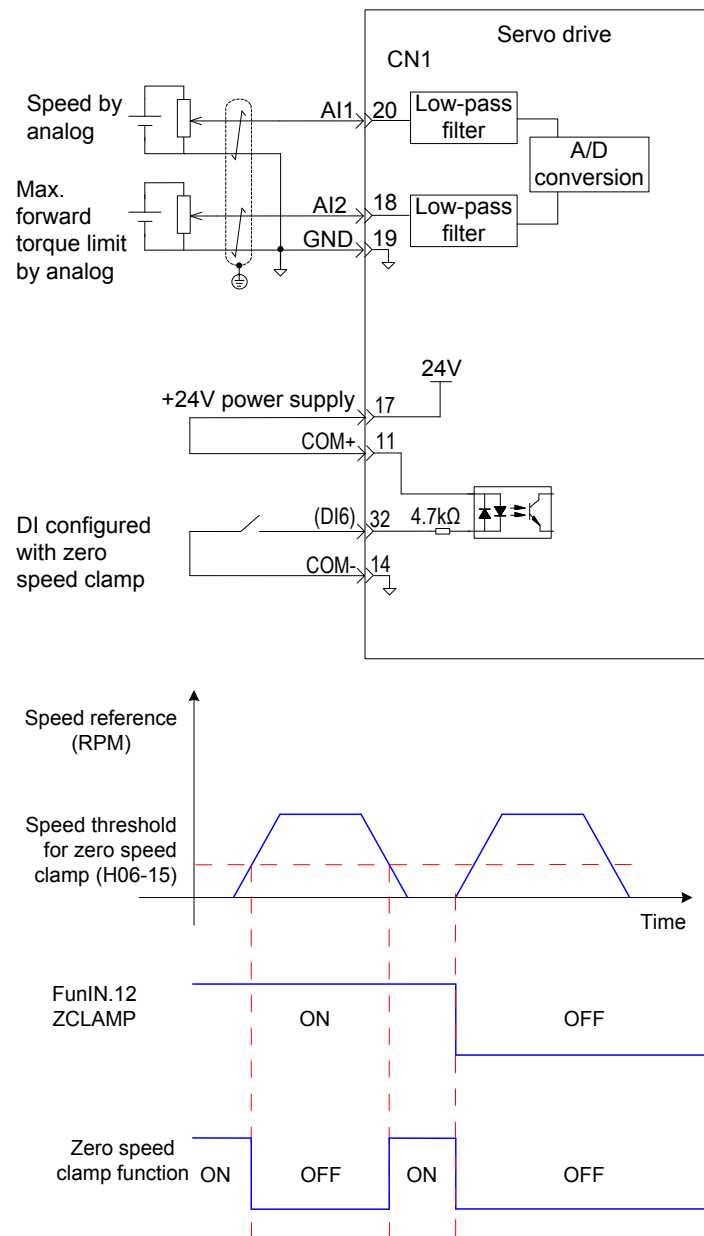

Relevant parameters:

Function Code	Parameter Name	Setting Range	Unit	Function	Property	Effective Time	Default
H06-15	Speed threshold for zero speed clamp	0 to 6000	RPM	Set the speed threshold for the zero speed clamp function.	During running	Immediate	10

Relevant function No.:

No.	Function Symbol	Function Name	Description
FunIN.12	ZCLAMP	Zero speed clamp	Valid: Zero speed clamp enabled Invalid: Zero speed clamp disabled

5.3.4 Speed Reference Limit



When the actual motor speed exceeds H0A-08 (Overspeed threshold), the servo drive reports Er.500 indicating motor overspeed. The speed reference must be smaller than H0A-08.

The speed references in the speed control mode can be limited.

H06-07 specifies both the positive and negative speed limits of speed reference. If speed reference exceeds the setting of H06-07, the speed reference will be limited as this value.

H06-08 specifies the positive speed limit. If positive speed reference exceeds the setting of H06-08, the reference will be limited as this value.

H06-09 specifies the negative speed limit. If reverse speed reference exceeds the setting of H06-09, the reference will be limited as this value..

The maximum motor speed varies with the actual motor model.

Figure 5-74 Speed reference limit

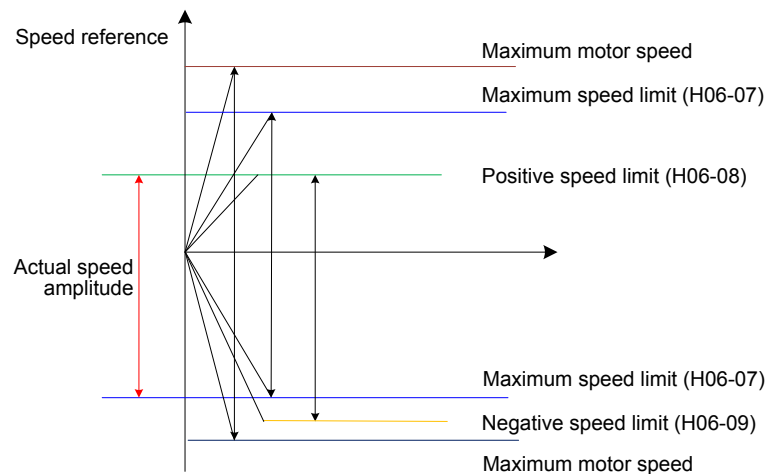

5

The actual motor speed limit meets the following requirements:

$$|\text{Positive speed limit}| \leq \min \{ \text{maximum motor speed, H06-07, H06-08} \}$$

$$|\text{Negative speed limit}| \leq \min \{ \text{motor rotational speed, H06-07, H06-09} \}$$

Relevant parameters:

Function Code	Parameter Name	Setting Range	Unit	Function	Property	Effective Time	Default
H06-07	Maximum speed limit	0 to 6000	RPM	Set the maximum speed limit.	During running	Immediate	6000
H06-08	Positive speed limit	0 to 6000	RPM	Set the positive speed limit.	During running	Immediate	6000
H06-09	Negative speed limit	0 to 6000	RPM	Set the negative speed limit.	During running	Immediate	6000

5.3.5 Speed-related DO Signals

Different DO signals are output to the host controller based on comparison between the speed feedback after filter and different thresholds. The related filter time is set in H0A-27.

1) Motor rotation DO signal

When the absolute value of the actual motor speed after filter reaches the setting of H06-16, the motor can be considered to rotate. At this moment, the servo drive outputs the motor rotation signal (FunOUT.2: TGON) to confirm that motor has rotated. When the absolute value of the actual motor speed after filter is smaller than the setting of H06-16, the motor is considered not to rotate.

Judgment on the motor rotation signal (FunOUT.2: TGON) is not influenced by the servo drive status and control mode.

Figure 5-75 Motor rotation signal waveform

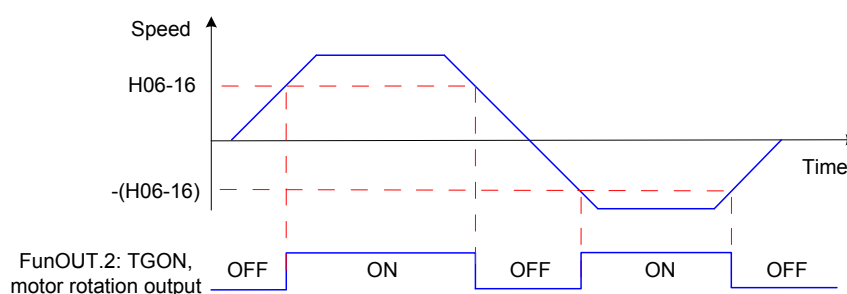

Note

In the preceding figure, ON indicates that the motor rotation DO signal is active. OFF indicates that the motor rotation DO signal is inactive.

Relevant parameters:

Function Code	Parameter Name	Setting Range	Unit	Function	Property	Effective Time	Default
H06-16	Speed threshold of motor rotation signal	0 to 1000	RPM	Set the speed threshold at which the motor rotation signal is active.	During running	Immediate	20

5

Set a DO terminal of the servo drive with function 2 (FunOUT.2: TGON, motor rotation output) and set the terminal logic.

Relevant function No.:

No.	Function Symbol	Function Name	Description
FunOUT.2	TGon	Motor rotation output	Valid: Motor speed absolute value after filter smaller than H06-16 Invalid: Motor speed absolute value after filter equal to or larger than H06-16

2) Speed consistent DO signal

In speed control, when the absolute value of the difference between the motor speed after filter and the speed reference satisfies the setting of H06-17, the actual motor speed is considered to reach the speed reference. At this moment, the servo drive outputs the speed consistent signal (FunOUT.4: V-CMP). When the absolute value of the difference between the motor speed after filter and the speed reference exceeds the setting of H06-17, the speed consistent signal is inactive.

If the servo drive is not in running status or in speed control, the speed consistent signal (FunOUT.4: V-CMP) is always inactive.

Figure 5-76 Speed consistent signal waveform

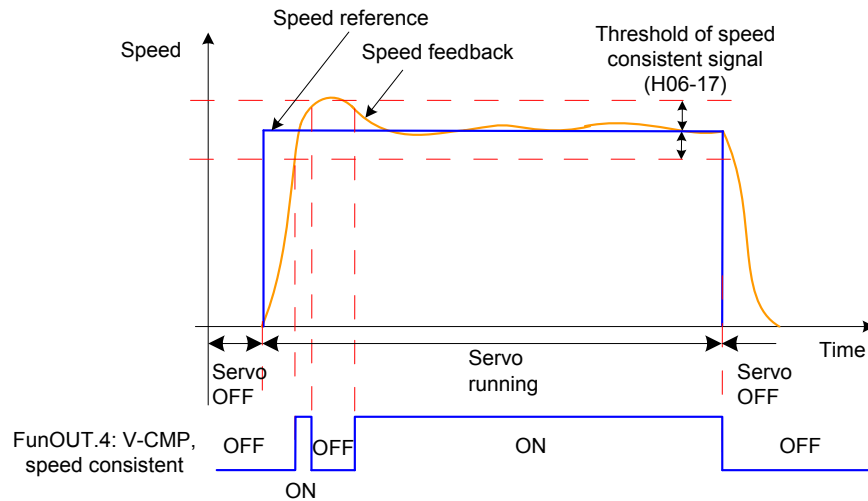

Note In the preceding figure, ON indicates that the speed consistent DO signal is active. OFF indicates that the speed consistent DO signal is inactive.

Relevant parameters:

Function Code	Parameter Name	Setting Range	Unit	Function	Property	Effective Time	Default
H06-17	Threshold of speed consistent signal	0 to 100	RPM	Set the threshold at which the speed consistent signal is active.	During running	Immediate	10

5

Set a DO terminal of the servo drive with function 4 (FunOUT.4:V-CMP, speed consistent) and set the terminal logic.

Relevant function No.:

No.	Function Symbol	Function Name	Description
FunOUT.4	V-CMP	Speed consistent	Invalid: The absolute value of the difference between the motor speed after filter and the speed reference is larger than H06-17. Valid: The absolute value of the difference between the motor speed after filter and the speed reference is equal to or smaller than H06-17.

3) Speed reached DO signal

When the absolute value of the motor speed after filter exceeds the setting of H06-18, the motor speed is considered to reach the desired value. At this moment, the servo drive outputs the speed reached signal (FunOUT.19: V-Arr). When the absolute value of the motor speed after filter is smaller than or equal to the setting of H06-18, the speed reached signal is inactive.

Judgment on the speed reached signal (FunOUT.19: V-Arr) is not influenced by the servo drive status and control mode.

Figure 5-77 Speed reached signal waveform

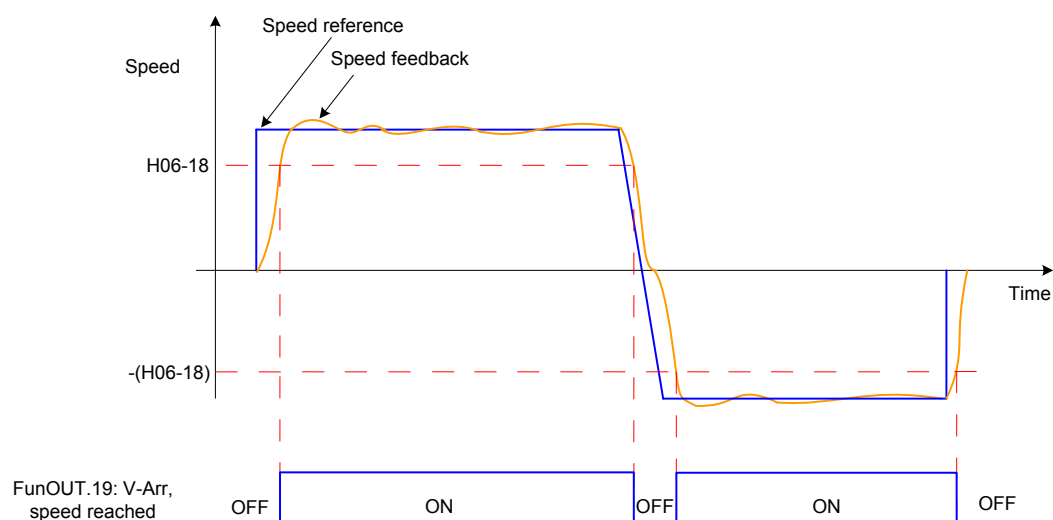
**Note**

In the preceding figure, ON indicates that the speed reached DO signal is active. OFF indicates that the speed reached DO signal is inactive.

Relevant parameters:

Function Code	Parameter Name	Setting Range	Unit	Function	Property	Effective Time	Default
H06-18	Threshold of speed reached signal	10 to 6000	RPM	Set the threshold at which the speed reached signal is active.	During running	Immediate	1000

Set a DO terminal of the servo drive with function 19 (FunOUT.19: V-Arr, speed reached) and set the terminal logic.

Relevant function No.:

5

No.	Function Symbol	Function Name	Description
FunOUT.19	V-Arr	Speed reached	Invalid: The absolute value of the speed feedback after filter is larger than H06-18. Invalid: The absolute value of the speed feedback after filter is equal to or smaller than H06-18.

4) Zero speed DO signal

When the absolute value of the motor speed after filter is smaller than the setting of H06-19, the motor speed is considered to be close to 0. At this moment, the servo drive outputs the zero speed signal (FunOUT.3: V-Zero). When the absolute value of the motor speed after filter is equal to or large than to the setting of H06-19, the zero speed signal is inactive.

Judgment on the zero speed signal (FunOUT.3: V-Zero) is not influenced by the servo drive status and control mode.

When there is interference on the speed feedback, eliminate the interference by using the speed feedback DO filter. Set the filter time constant in H0A-27.

Figure 5-78 Zero speed signal waveform

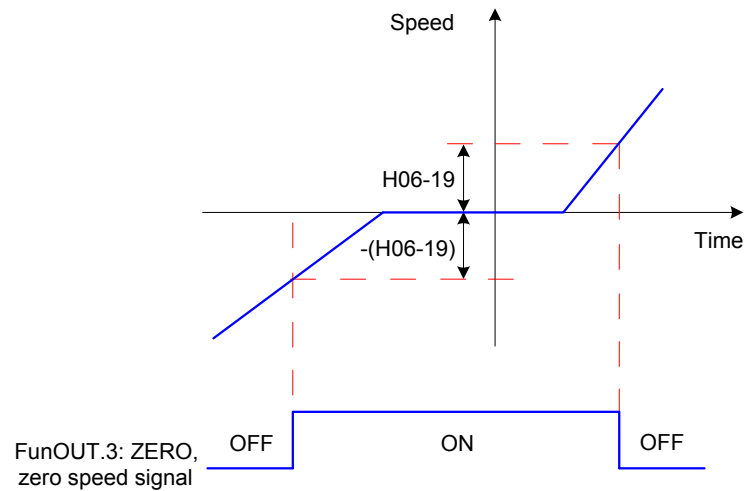

Note In the preceding figure, ON indicates that the zero speed DO signal is active. OFF indicates that the zero speed DO signal is inactive.

Relevant parameters:

Function Code	Parameter Name	Setting Range	Unit	Function	Property	Effective Time	Default
H06-19	Threshold of zero speed output signal	1 to 6000	RPM	Set the threshold at which the zero speed signal is active.	During running	Immediate	10

Set a DO terminal of the servo drive with function 3 (FunOUT.3: ZERO, zero speed) and set the terminal logic.

5

Relevant function No.:

No.	Function Symbol	Function Name	Description
FunOUT.3	V-Zero	Zero speed signal	Invalid: The absolute deviation between the motor speed feedback and the speed reference is larger than the setting of H06-19. Valid: The absolute deviation between the motor speed feedback and the speed reference is smaller than or equal to the setting of H06-19.

5.3.6 Function Code Block Diagram

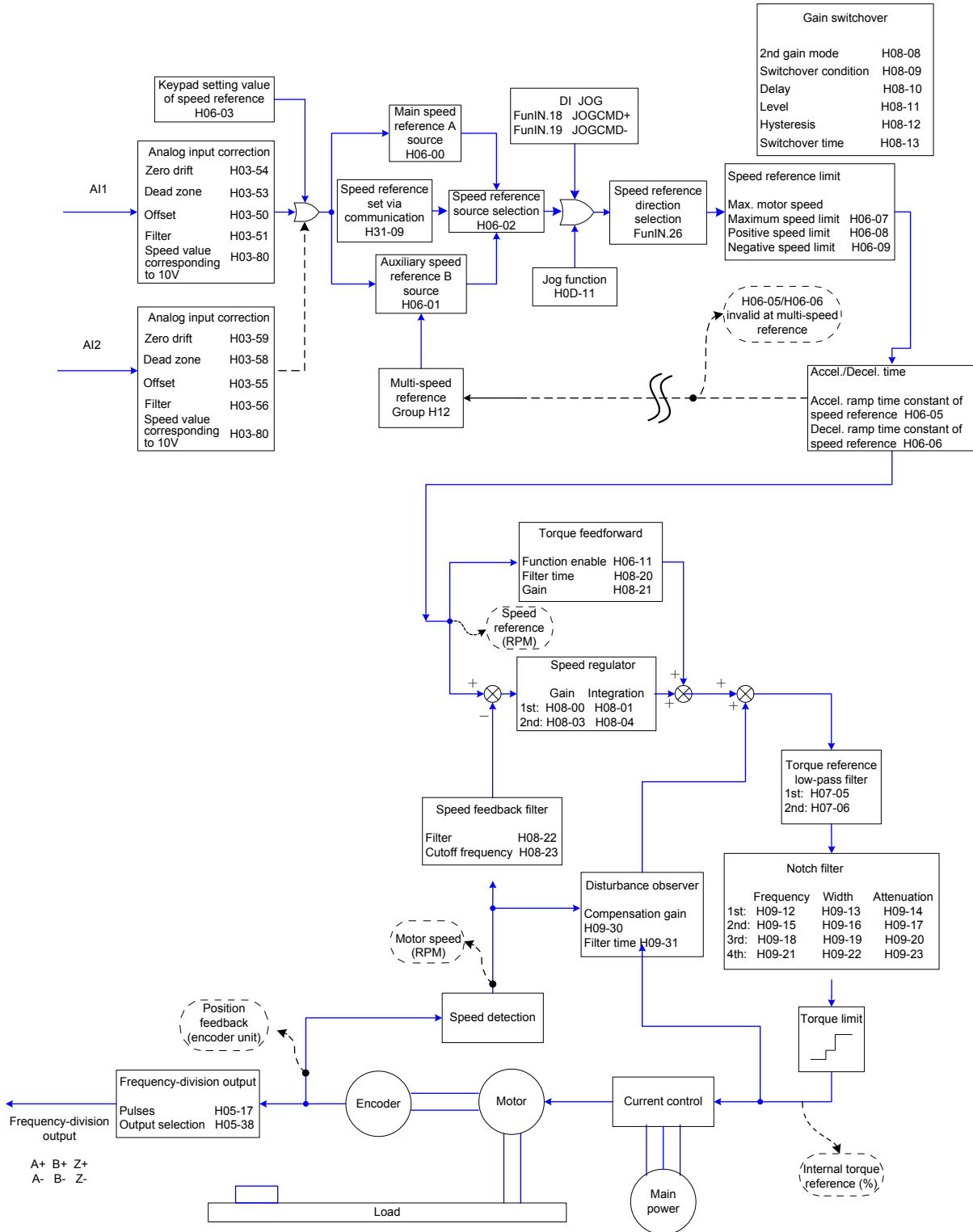

5.4 Torque Control Mode

Figure 5-79 Block diagram of the torque control mode

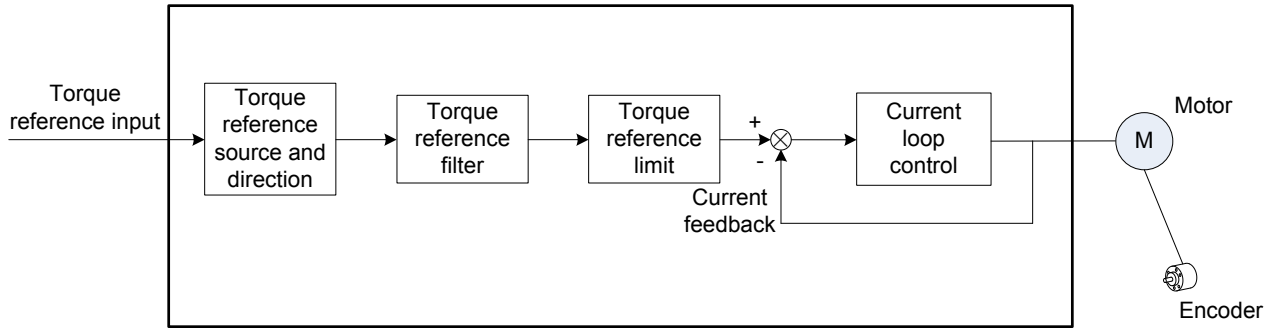

Set H02-00 to 2 on the keypad or Inovance servo commissioning software to enable the torque control mode.

Set the servo drive parameters based on the mechanical structure and specifications. The following part uses the basic parameter setting to describe the torque control mode.

Figure 5-80 Signal exchange between the servo drive and the host controller

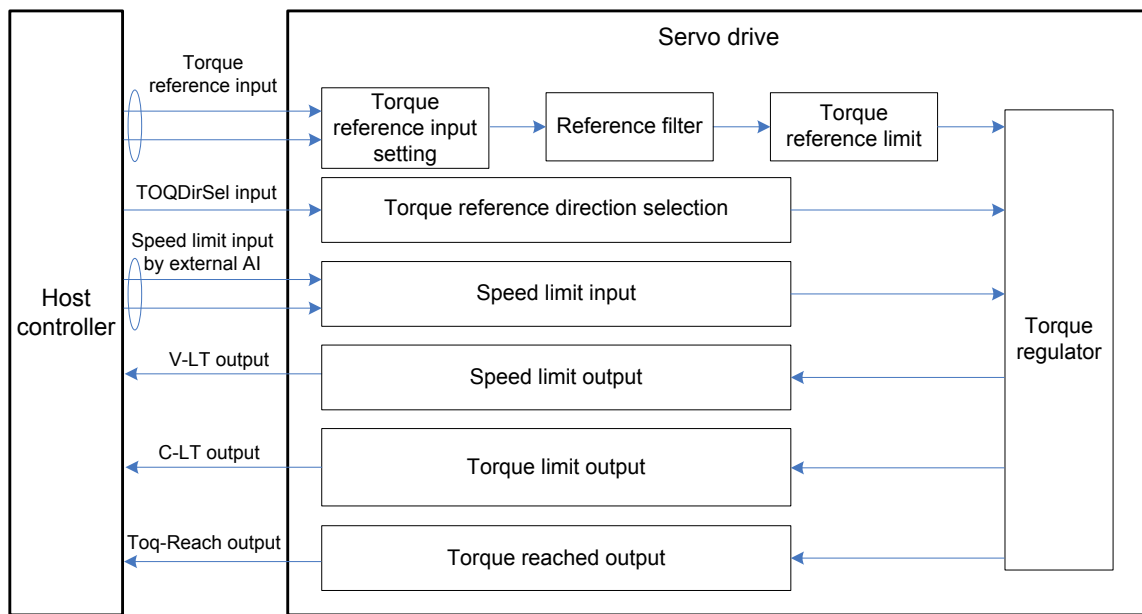

5

5.4.1 Torque Reference Input Setting

1) Torque reference source

In the torque control mode, five methods of obtaining torque references are available, and you can select one in H07-02.

Figure 5-81 Selection of torque reference source

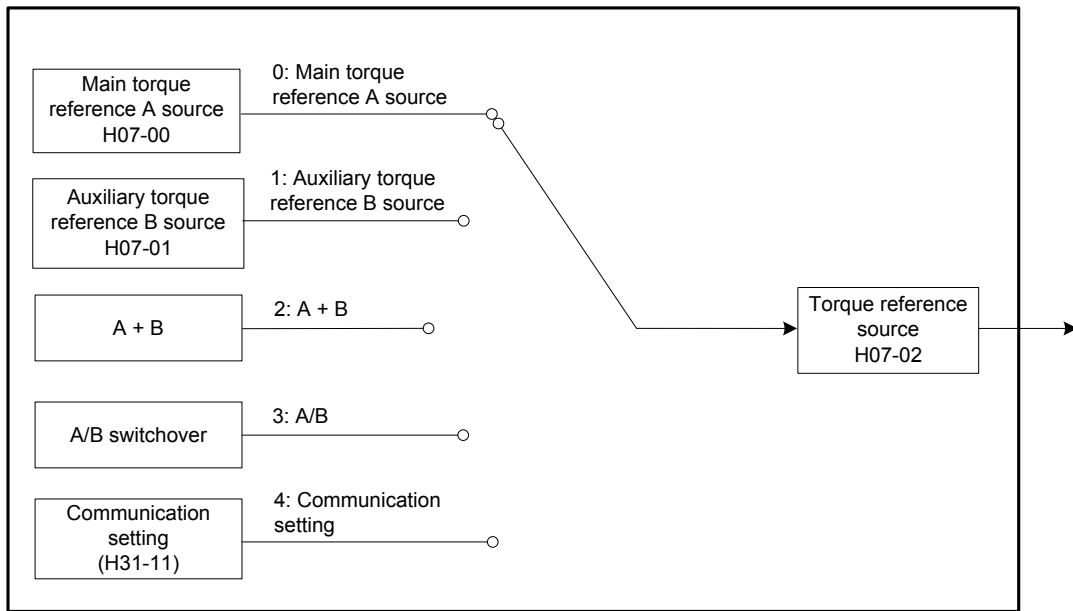

Relevant parameters:

Function Code	Parameter Name	Setting Range	Unit	Function	Property	Effective Time	Default
H07-02	Torque reference source	0: Main torque reference A source 1: Auxiliary torque reference B source 2: A + B 3: A/B switchover 4: Communication setting	-	Select the torque reference source.	At stop	Immediate	0

a. Main torque reference A source

The main torque reference A sources include digital setting and analog voltage setting. Digital setting produces the internal speed reference, and the analog voltage setting produces the external speed reference.

Figure 5-82 Main torque reference A source

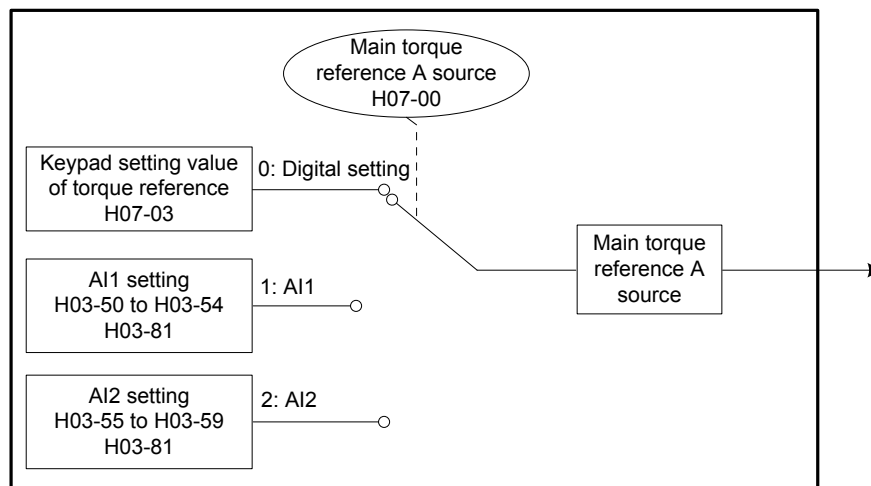

Relevant parameters:

Function Code	Parameter Name	Setting Range	Unit	Function	Property	Effective Time	Default
H07-00	Main torque reference A source	0: Digital setting (H07-03) 1: AI1 2: AI2	-	Select the source of main torque reference A.	At stop	Immediate	0

■ Digital setting

The torque reference is set in H07-03 as a percentage relative to the rated motor torque.

Relevant parameters:

Function Code	Parameter Name	Setting Range	Unit	Function	Property	Effective Time	Default
H07-03	Keypad setting value of torque reference	-300.0 to 300.0	%	Set the torque reference, in unit of 0.1%.	During running	Immediate	0

■ Analog voltage setting

The analog voltage signal output by the host controller or other devices is processed and then used as the torque reference.

Analog voltage input terminal:

The servo drive provides two analog input channels, AI1 and AI2, with maximum input voltage ± 10 VDC, input impedance 9 k Ω .

Analog input circuit:

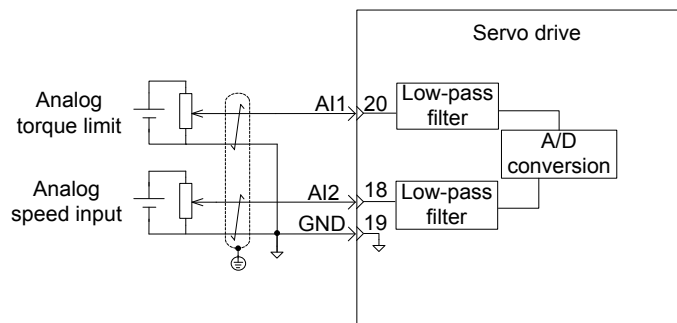

Operation method:

The following table takes AI1 as an example to describe the analog setting of the torque reference.

Figure 5-83 Operation flowchart of setting torque reference by analog voltage

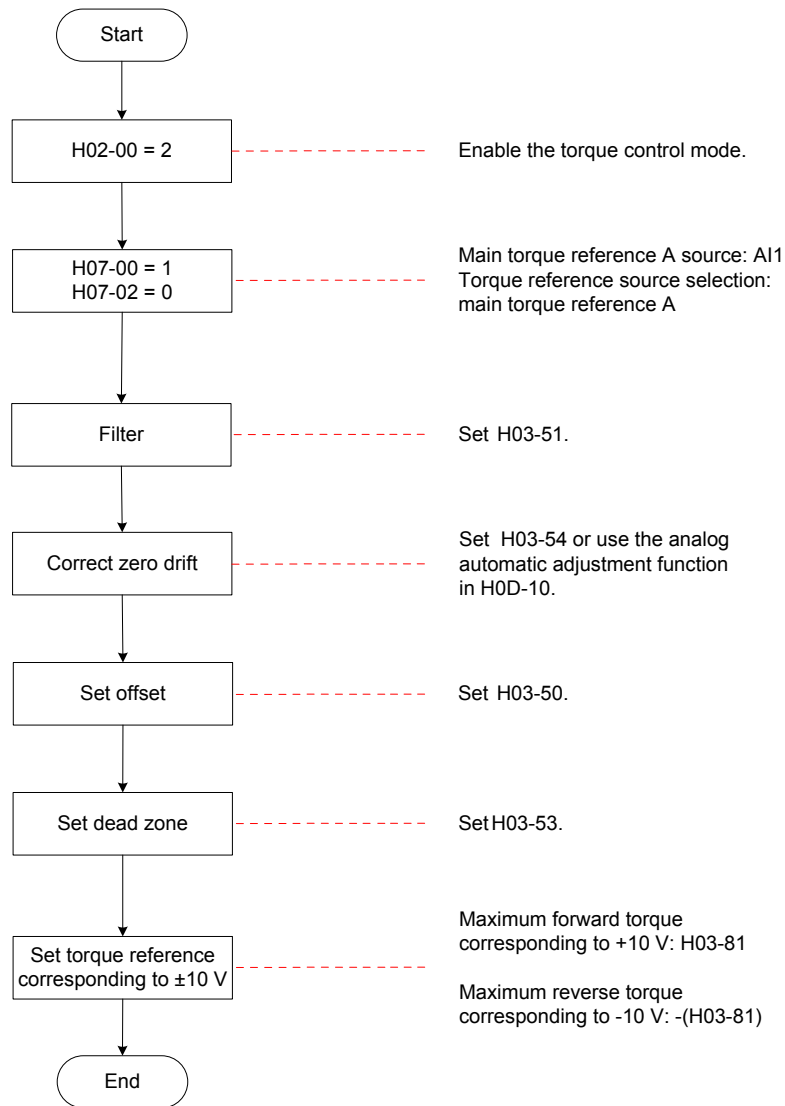

Zero drift: value of the servo drive sampling voltage relative to GND when the input voltage of the analog channel is zero

Offset: input voltage value of the analog channel when the sampling voltage is zero after zero drift correction

Dead zone: input voltage range of the analog channel when the sampling voltage is zero

In the following figure, y_1 is the output voltage of the analog channel not processed, and y_6 is the final torque reference.

Figure 5-84 AI processing of servo drive

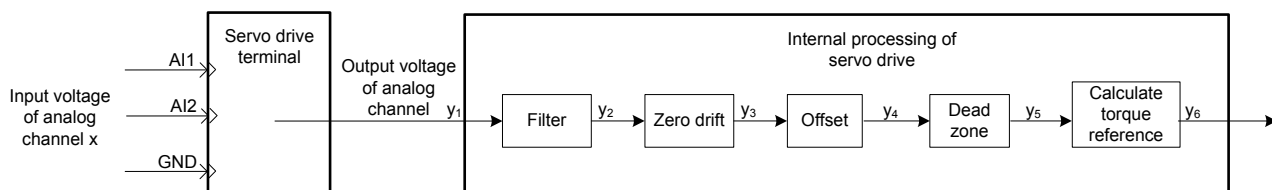
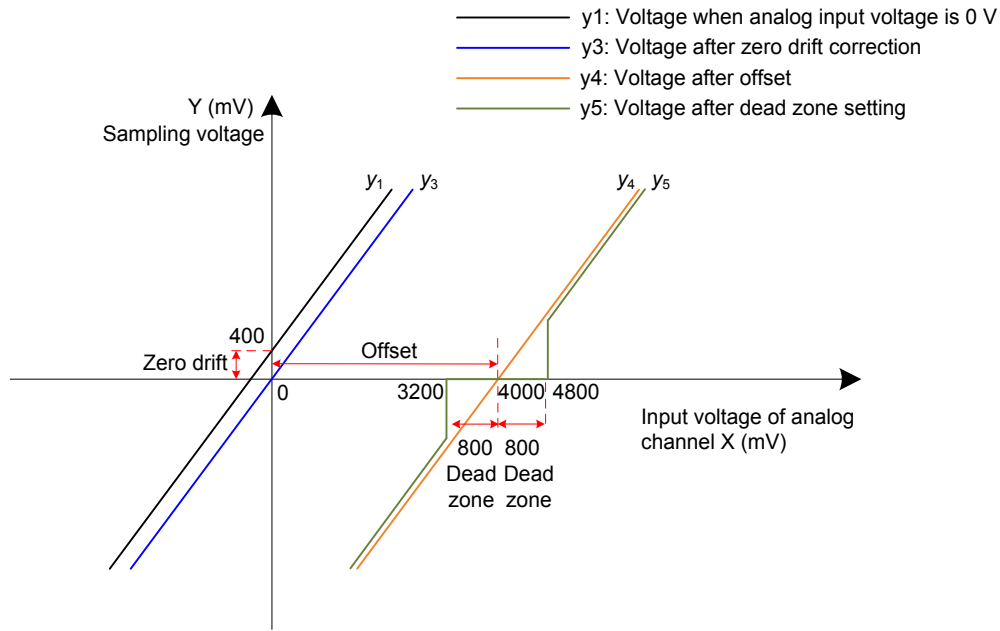

Figure 5-85 Sampling voltage example for servo drive AI processing



- Filter:

The servo drive provides the analog channel filter function. Setting the filter time constant in H03-51 prevents motor reference fluctuation due to instable analog input voltage and eliminates motor malfunction due to signal interference. The filter function cannot eliminate or suppress the zero drift or dead zone.

- Zero drift correction:

It corrects the analog output voltage offset relative to the actual input voltage 0 V.

In the preceding figure, the analog output voltage without being processed by the servo drive is y_1 . Take the filter time constant H03-51 = 0.00 ms as an example, and the sampling voltage after filter y_2 is the same as y_1 .

That is, when the actual input voltage $x = 0$, the output voltage $y_1 = 400$ mV. Therefore, the zero drift voltage is 400 mV.

Set H03-54 to 400.0 (mV). The sampling voltage after zero drift correction is shown as y_3 .

$$y_3 = y_1 - 400.0$$

Zero drift correction can also be carried out by using the analog automatic adjustment function in H0D-10.

- Offset setting:

It sets the actual input voltage corresponding to sampling voltage 0.

Assume that the actual input voltage $x = 4000$ mV when the sampling voltage $y_3 = 0$. That is, the offset is 4000 mV.

Set H03-50 to 4000 (mV). The sampling voltage after offset $y_4 = y_3 + 4000$

- Dead zone correction:

It sets the effective input voltage range when the sampling voltage of the servo drive is not 0.

After the offset is set, if the sampling voltage is always 0 when the input voltage x is within 3200 mV to 4800 mV, the dead zone is 800 mV.

5

Set H03-53 to 800 (mV). The sampling voltage after dead zone correction is shown as y_5 :

$$y_5 = \begin{cases} 0 & 3200 \leq x \leq 4800 \\ y_4 & 4800 < x \leq 10000 \text{ or } -10000 \leq x < 3200 \end{cases}$$

- Speed reference calculation:

After setting the zero drift, offset, and dead zone, set the torque corresponding to 10 V (10000 mV) in H03-81 to obtain the actual torque reference y_6 :

$$y_6 = \frac{y_5}{10000} \times (\text{H03-80})$$

This value is used as the torque reference set via analog in the torque control mode.

The following figures show the relationship between analog input and torque values when the offset is absent and present. After all setting is completed correctly, view the sampling voltage of AI1 in H0B-21 or the torque reference corresponding to analog input in H0B-02.

Figure 5-86 No-offset AI1

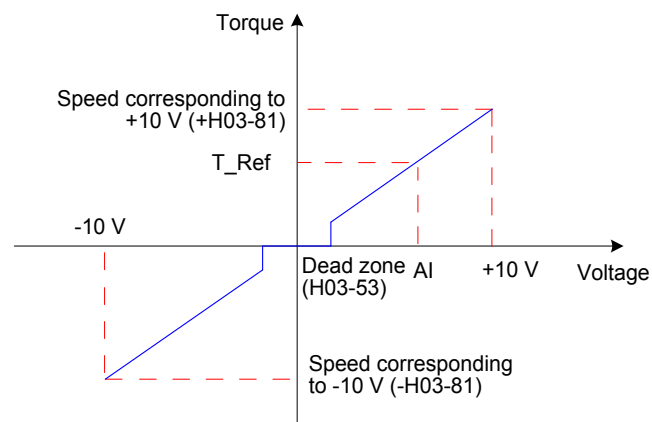
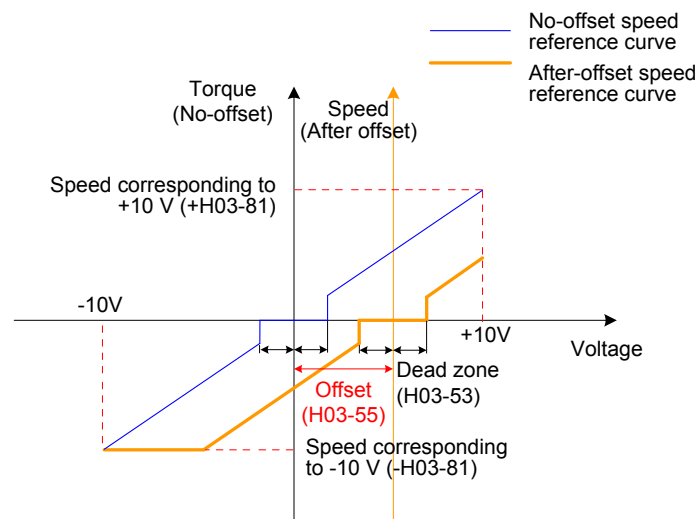

Figure 5-87 After-offset AI1



The relationship between the final torque reference y_6 and the input voltage x is:

$$y_6 = \begin{cases} 0 & B - C \leq x \leq B + C \\ (x - B) \times \frac{\text{H03-80}}{10} & B + C < x \leq 10000 \text{ or } -10000 \leq x < B - C \end{cases}$$

B: offset, C: dead zone

Relevant parameters:

Function Code	Parameter Name	Setting Range	Unit	Function	Property	Effective Time	Default
H03-50	AI1 offset	-5000 to 5000	mV	Set the offset of the analog channel AI1.	During running	Immediate	0
H03-51	AI1 filter time constant	0 to 655.35	ms	Set the moving average filter time constant of the analog channel AI1.	During running	Immediate	2.00
H03-53	AI1 dead zone	0 to 1000.0	mV	Set the dead zone of the analog channel AI1.	During running	Immediate	10.0
H03-54	AI1 zero drift	-500.0 to 500.0	mV	Set the zero drift of the analog channel AI1.	During running	Immediate	0.0
H03-81	Torque corresponding to 10 V	1.00 to 8.00 times of rated torque	times	Set the torque corresponding to sampling voltage 10 V.	At stop	Immediate	1.00
H0D-10	Analog automatic adjustment	0: Disabled 1: AI1 adjustment 2: AI2 adjustment	-	Set whether to enable automatic zero drift correction of AI1 and AI2.	At stop	Immediate	0

Note	The setting method of AI2 is the same as that of AI1 described above. For the detailed parameter descriptions, refer to Chapter 7.
-------------	--

5

b. Auxiliary torque reference B source

The auxiliary torque reference B source is set in the same way as the main torque reference A source. For the descriptions of related parameters, refer to Chapter 7.

c. A/B switchover

When H07-02 = 3 (A/B switchover), set a DI terminal with FunIN.4 (CMD-SEL, main/Auxiliary reference switchover). The signal of the DI terminal determines whether the main or auxiliary reference source is valid.

Relevant function No.:

No.	Function Symbol	Function Name	Description
FunIN.4	CMD-SEL	Main/Auxiliary reference switchover	Valid: Current running reference being A Invalid: Current running reference being B

d. Communication setting

When H07-02 = 4 (Communication setting), the torque reference is the value of H31-11, and H31-11 is not displayed on the keypad and can be set only via communication.

Relevant parameters:

Function Code	Parameter Name	Setting Range	Unit	Function	Property	Effective Time	Default
H31-11	Torque reference set via communication	-100.000 to 100.000	%	Set the torque reference (in unit of 0.001%) when the torque reference source is communication setting.	During running	Immediate	-

2) Torque reference direction

A DI terminal with FunIN.25 (TOQDirSel, torque reference direction selection) is used to change the torque reference direction.

Relevant function No.:

No.	Function Symbol	Function Name	Description
FunIN.25	ToqDirSel	Torque reference direction selection	Valid: Forward direction Invalid: Reverse direction

The actual motor direction is related to the rotating direction in H02-02, positive/negative of torque reference, torque reference direction (FunIN.25).

Table 5-25 Actual motor rotating direction in torque control mode

H02-02	Positive/Negative of Torque Reference	FunIN.25	Actual Motor Rotating Direction
0	+	Invalid	Counterclockwise
0	+	Valid	Clockwise
0	-	Invalid	Clockwise
0	-	Valid	Counterclockwise
1	+	Invalid	Clockwise
1	+	Valid	Counterclockwise
1	-	Invalid	Counterclockwise
1	-	Valid	Clockwise

5

5.4.2 Torque Reference Filter



CAUTION

A very large filter time constant reduces the response. Check the response during the setting.

In the position, speed, torque and hybrid control modes, the servo drive can carry out low-pass filter on torque references to smoothens references and decreases vibration.

The servo drive provides two low-pass filters for torque references. By default, the 1st filter is used.

When the gain switchover function is used (H08-08 = 1 and H08-09 ≠ 0), and the condition of H08-09 is met, the 2nd filter is used.

Relevant parameters:

Function Code	Parameter Name	Setting Range	Unit	Function	Property	Effective Time	Default
H07-05	Time constant of torque reference filter	0 to 30.00	ms	Set the time constant of the 1st torque reference low-pass filter.	During running	Immediate	0.79
H07-06	2nd time constant of torque reference filter	0 to 30.00	ms	Set the time constant of the 2nd torque reference low-pass filter.	During running	Immediate	0.79

Figure 5-88 Diagram of rectangular torque reference first-order filter

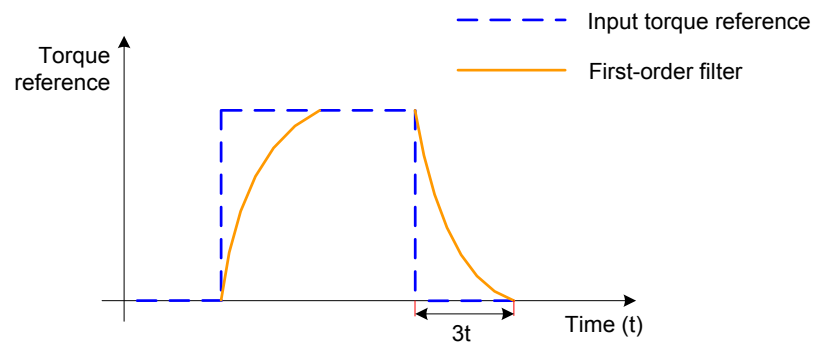
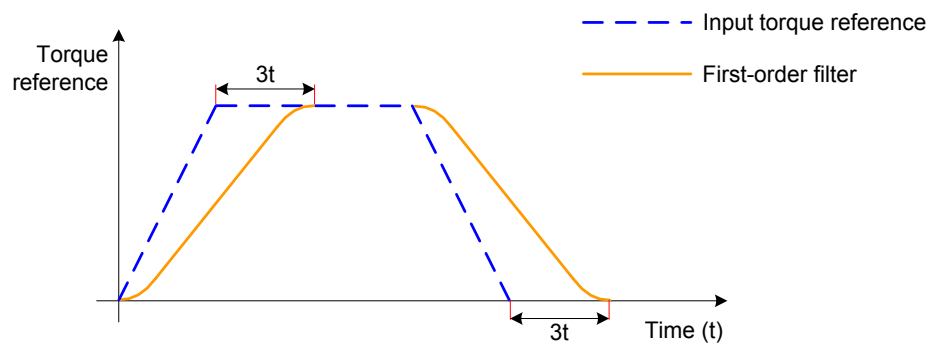

Figure 5-89 Diagram of trapezoid torque reference first-order filter



5.4.3 Torque Reference Limit



Torque reference limit is mandatory in the position control, speed control, torque control and hybrid control modes.

Torque references are limited to protect the servo drive and motor.

Figure 5-90 Torque setting and limit

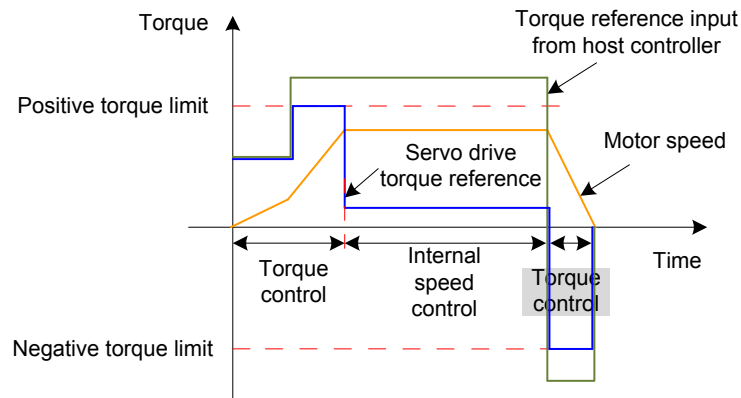

When the absolute value of the torque reference input from the host controller or output by the speed regulator is larger than the absolute value of the torque reference limit, the actual torque reference of the servo drive is restricted to the torque reference limit. Otherwise, the torque reference input from the host controller or output by the speed regulator is used.

Only one torque reference limit is valid at a moment. Both positive and negative torque limits does not exceed the maximum torques of the servo drive and motor and $\pm 300.0\%$ of the rated torque.

Figure 5-91 Torque limit example

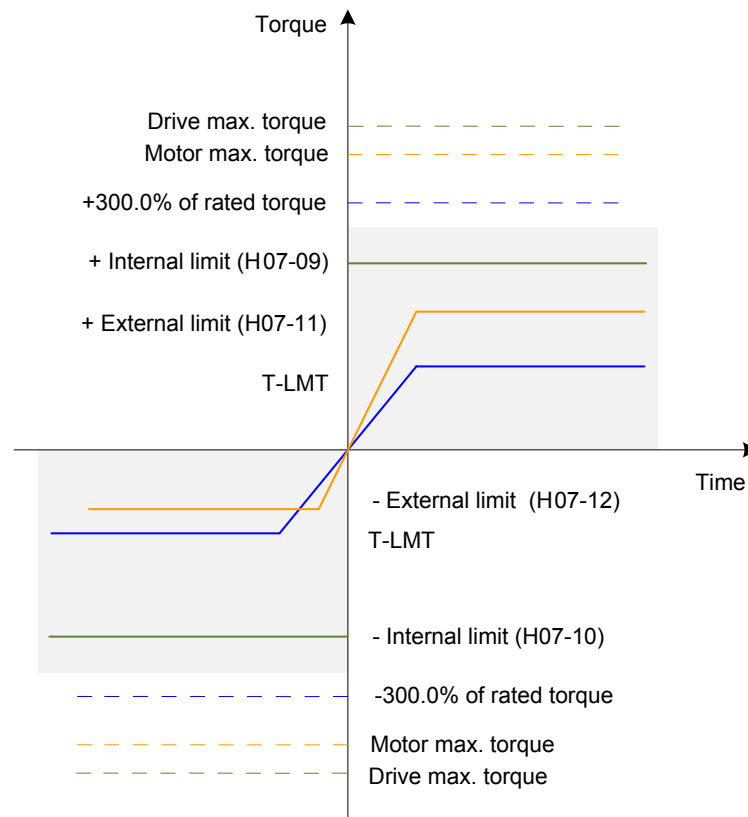

1) Torque limit source

The torque limit source is set in H07-07. After the torque limit is set, the servo drive torque reference is restricted to within the torque limit. After the torque reference reaches the limit, the motor runs according to the torque limit. The torque limit must be set according to the load conditions. If the setting is very small, it may cause longer acceleration/deceleration time of the motor, and the actual motor speed may not reach the required value at constant speed running.

Relevant parameters:

Function Code	Parameter Name	Setting Range	Unit	Function	Property	Effective Time	Default
H07-07	Torque limit source	0: Internal positive/negative torque limit 1: External positive/negative torque limit (via P-CL, N-CL) 2: T-LMT as external torque limit 3: Minimum of external positive/negative torque and external T-LMT as torque limit (via P-CL, N-CL) 4: Switchover between internal positive/negative torque limit and T-LMT torque limit (via P-CL, N-CL)	-	Select the torque limit source.	At stop	Immediate	0

Figure 5-92 Torque limit source

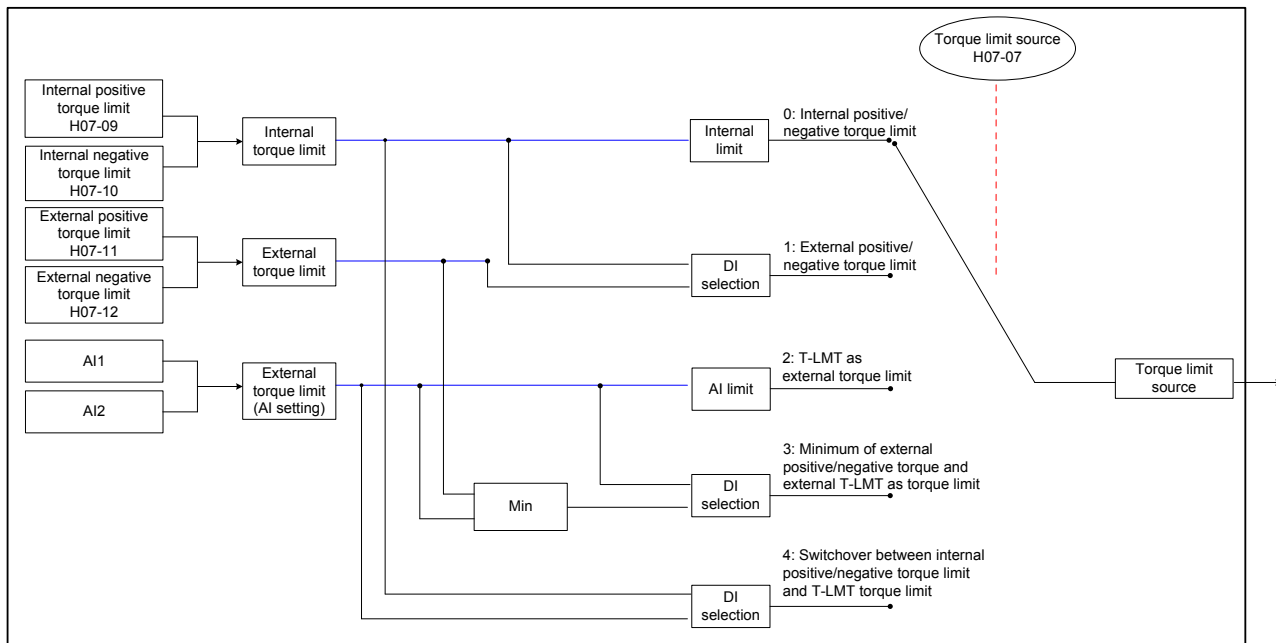

The following figures show the torque limit curve when the absolute torque reference input from the host controller is larger than the torque limit.

a. H07-07 = 0 (Internal positive/negative torque limit)

The torque reference limit value is determined only by H07-09 and H07-10.

5

Figure 5-93 Torque limit curve when H07-07 = 0

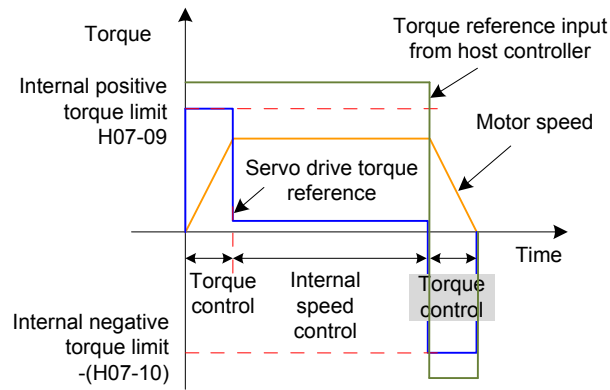

a. H07-07 = 1 (External positive/negative torque limit)

The torque reference limit value is determined by the logic state of external DI signals. The positive limit value is selected between H07-09 and H07-11, and the negative limit value is selected between H07-10 and H07-12.

Figure 5-94 Torque limit source H7-07 = 1

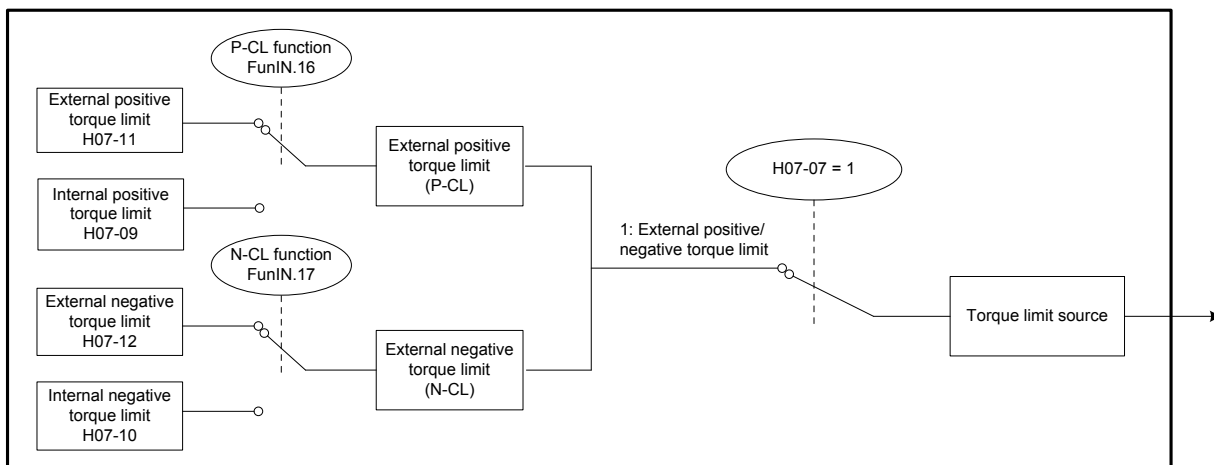
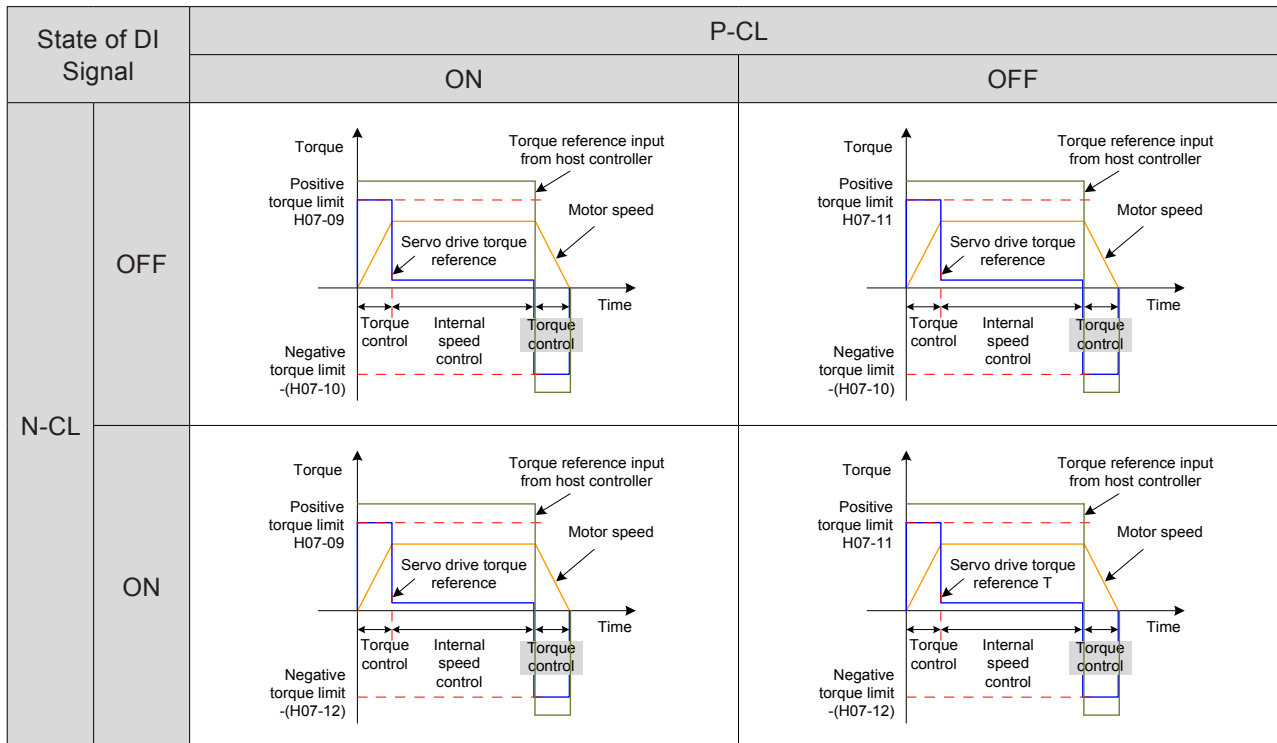

Table 5-26 Descriptions of H07-07 = 1



Set two DI terminals of the servo drive respectively with function 16 (FunIN.16: P-CL, external positive torque limit) and function 17 (FunIN.17: N-CL, external negative torque limit) and set the terminal logics.

Relevant function No.:

No.	Function Symbol	Function Name	Description
5	FunIN.16	P-CL External positive torque limit	The torque limit source is switched over based on the setting of H07-07. H07-07 = 1: Valid: External positive torque limit enabled Invalid: Internal positive torque limit enabled H07-07 = 3 and AI limit larger than external positive limit Valid: External positive torque limit enabled Invalid: AI torque limit enabled H07-07 = 4: Valid: AI torque limit enabled Invalid: Internal positive torque limit enabled

No.	Function Symbol	Function Name	Description
FunIN.17	N-CL	External negative torque limit	<p>The torque limit source is switched over based on the setting of H07-07.</p> <p>H07-07 = 1: Valid: External negative torque limit enabled Invalid: Internal negative torque limit enabled</p> <p>H07-07 = 3 and AI limit larger than external negative limit Valid: External negative torque limit enabled Invalid: AI torque limit enabled</p> <p>H07-07 = 4: Valid: AI torque limit enabled Invalid: Internal negative torque limit enabled</p>

c. H07-07 = 2 (T-LMT as external torque limit)

The torque limit is determined by the torque corresponding to the input voltage of the AI terminal selected in H07-08.

Figure 5-95 Torque limit source H7-07 = 2

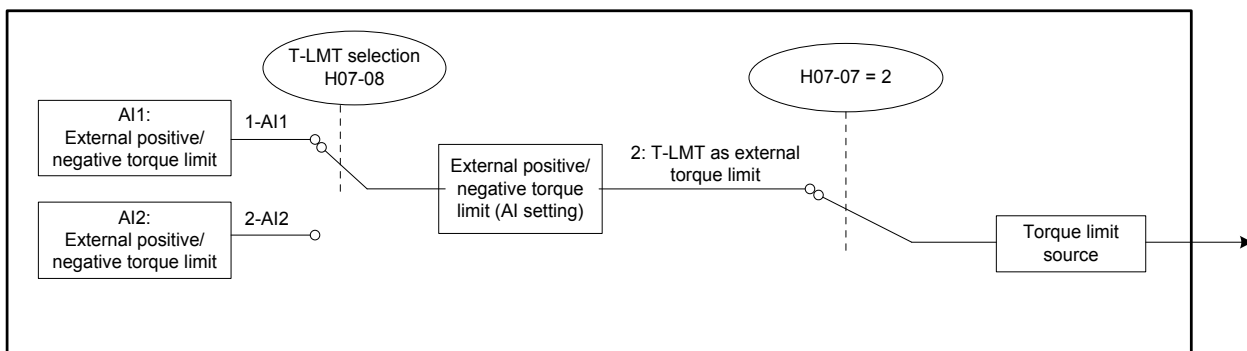

5

Figure 5-96 Torque limit curve when H07-07 = 2

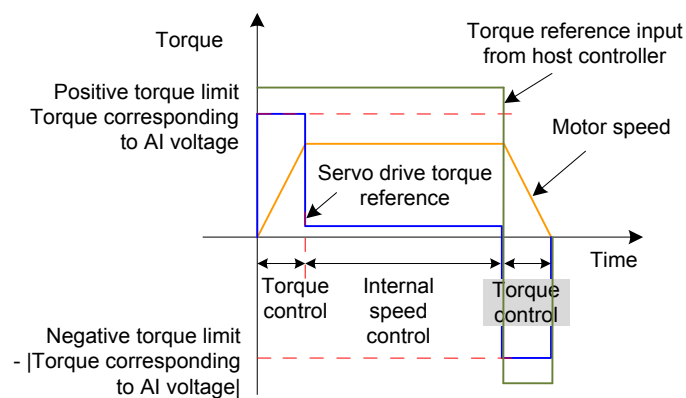

For the setting of the relationship between the torque and the analog voltage for AI1 and AI2, refer to Chapter 7.

d. H07-07 = 3 (Minimum of external positive/negative torque and external T-LMT as torque limit)

Positive torque limit: based on the AI terminal selected in H07-08

When the logic of the external DI signal (P-CL) is invalid, the positive torque limit is determined by

the torque corresponding to the input voltage of the AI terminal.

When the logic of the external DI signal (P-CL) is valid, the positive torque limit is determined by the smaller between H07-11 and the torque corresponding to the input voltage of the AI terminal.

Negative torque limit: based on the AI terminal selected in H07-08

When the logic of the external DI signal (N-CL) is invalid, the negative torque limit is determined by the torque corresponding to the input voltage of the AI terminal.

When the logic of the external DI signal (N-CL) is valid, the negative torque limit is determined by the smaller between H07-12 and the torque corresponding to the input voltage of the AI terminal.

Figure 5-97 Torque limit source H7-07 = 3

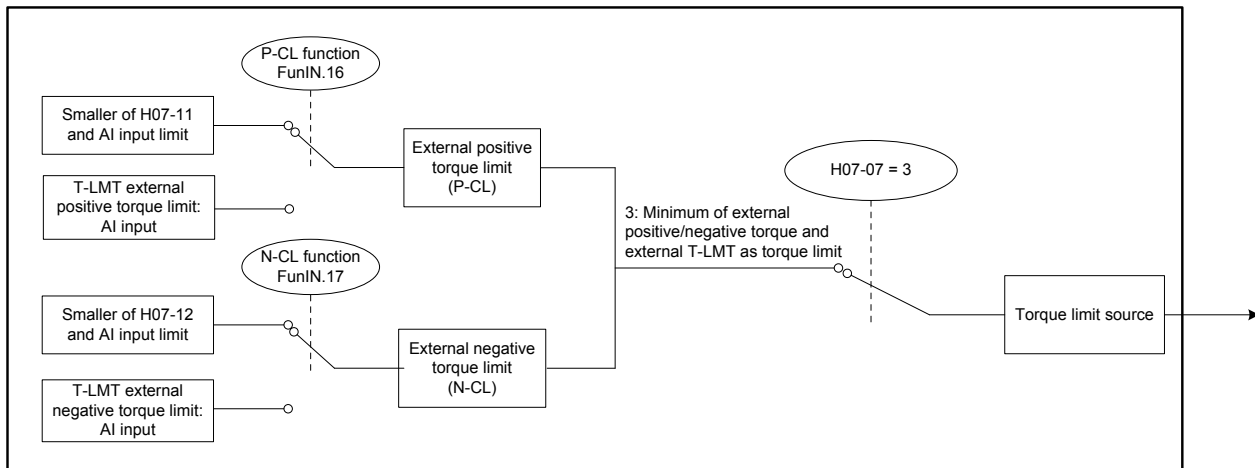

Table 5-27 Descriptions of H07-07 = 3

State of DI Signal		P-CL	
		ON	OFF
N-CL	OFF		
	ON		

e. H07-07 = 4 (Switchover between internal positive/negative torque limit and T-LMT torque limit)

Positive torque limit: based on the AI terminal selected in H07-08

When the logic of the external DI signal (P-CL) is invalid, the positive torque limit is determined by

5

H07-09.

When the logic of the external DI signal (P-CL) is valid, the positive torque limit is determined by the torque corresponding to the input voltage of the AI terminal.

Negative torque limit: based on the AI terminal selected in H07-08

When the logic of the external DI signal (N-CL) is invalid, the negative torque limit is determined by H07-10.

When the logic of the external DI signal (N-CL) is valid, the negative torque limit is determined by the torque corresponding to the input voltage of the AI terminal.

Figure 5-98 Torque limit source H7-07 = 4

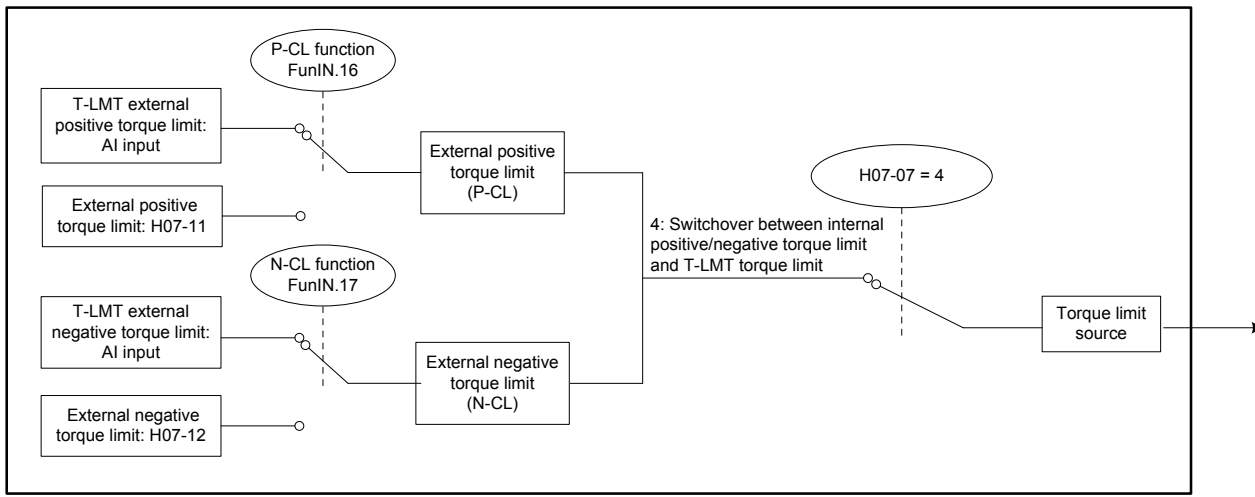

Table 5-28 Descriptions of H07-07 = 4

State of DI Signal		P-CL	
		ON	OFF
N-CL	OFF		
	ON		

Relevant parameters:

Function Code	Parameter Name	Setting Range	Unit	Function	Property	Effective Time	Default
H07-08	T-LMT selection	1: AI1 2: AI2	-	Select the analog input channel of the torque limit signal.	At stop	Immediate	2
H07-09	Internal positive torque limit	0 to 300.0	%	Set the internal positive/negative torque limit value (100.0% corresponds to one time of rated motor torque).	During running	Immediate	300.0
H07-10	Internal negative torque limit	0 to 300.0	%		During running	Immediate	300.0
H07-11	External positive torque limit	0 to 300.0	%	Set the external positive/negative torque limit value (100.0% corresponds to one time of rated motor torque).	During running	Immediate	300.0
H07-12	External negative torque limit	0 to 300.0	%		During running	Immediate	300.0

2) Torque limit DO signal

When the torque reference reaches the torque limit, the servo drive outputs the torque limit signal to the host controller. Set a DO terminal of the servo drive with function 7 (FunOUT.7: C-LT, torque limit) and set the terminal logic.

Relevant function No.:

No.	Function Symbol	Function Name	Description
FunOUT.7	C-LT	Torque limit	Valid: Servo drive torque reference reaching the torque limit value and restricted to this value Invalid: Servo drive torque reference not reaching the torque limit value

5

5.4.4 Speed Limit in Torque Control

In the torque control mode, if the torque reference is larger than the load torque on mechanical side, the motor keeps accelerating, which may cause overspeed and damages the machine. The motor speed needs to be limited to protect the machine.

Figure 5-99 Diagram of speed limit in torque control

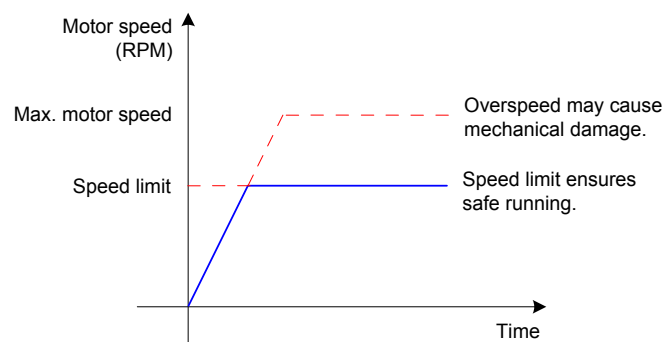

1) Speed limit source

The speed limit source in torque control is selected in H07-17. After the speed limit is set, the actual motor speed is restricted to within the speed limit. After the motor speed reaches the speed limit, the motor keeps constant-speed running at the speed limit value. The speed limit must be set according to the load conditions.

Relevant parameters:

Function Code	Parameter Name	Setting Range	Unit	Function	Property	Effective Time	Default
H07-17	Speed limit source	0: Internal speed limit 1: V-LMT as external speed limit 2: Speed limit selected via DI	-	Select the speed limit source in torque control mode.	Immediate	During running	0

Figure 5-100 Speed limit source

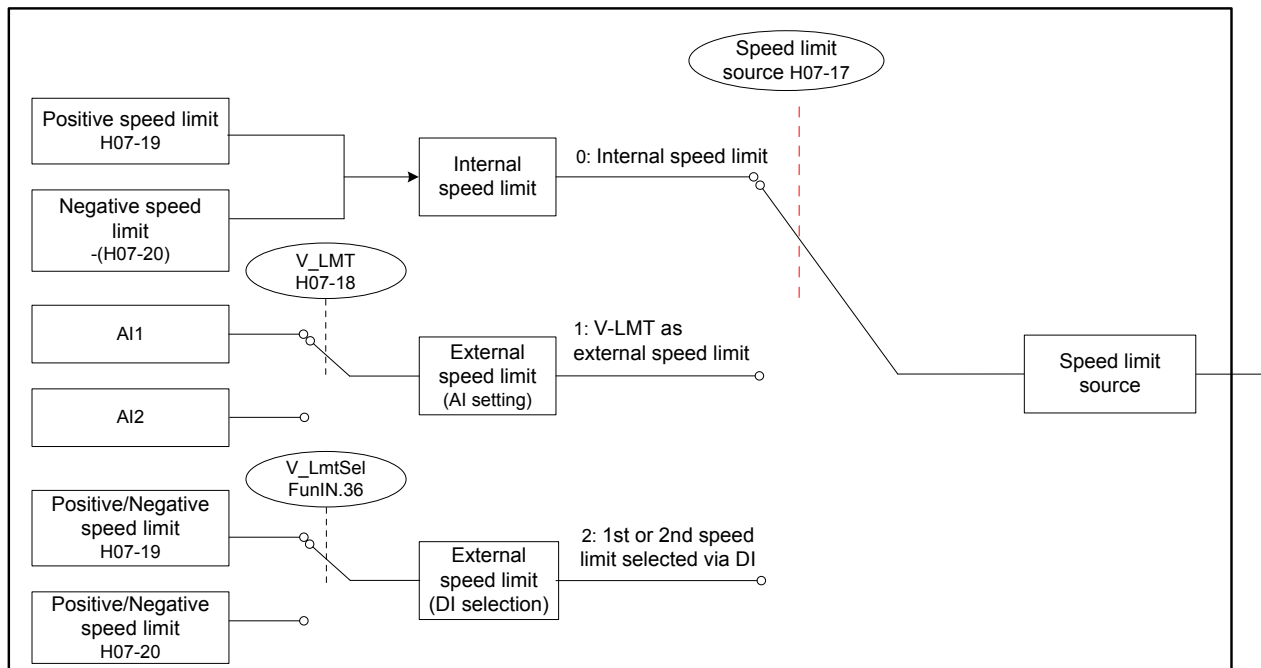

a. H07-17 = 0 (Internal speed limit)

The speed limit in different motor directions is determined only by H07-19 and H07-20.

Figure 5-101 Speed limit curve when H07-17 = 0

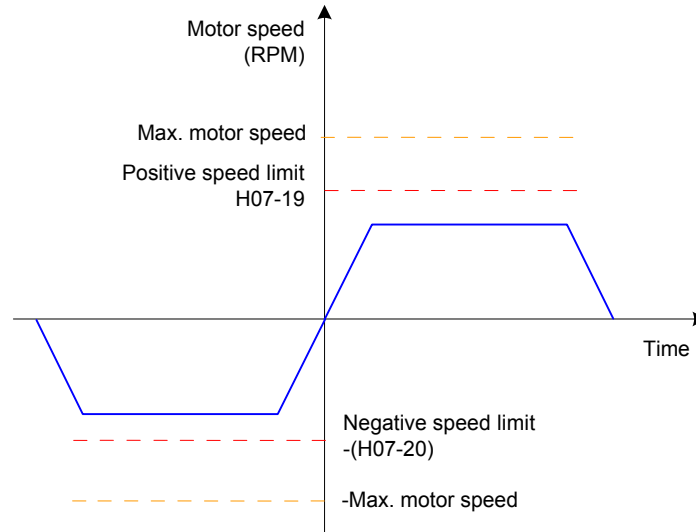

a. H07-17 = 1 (V-LMT as external speed limit)

The voltage for speed limit is input from the AI terminal selected in H07-18. When the speed limit corresponding to the AI voltage is smaller than internal speed limit (H07-19/H07-20), the speed limit corresponding to the AI voltage is valid. When the speed limit corresponding to the AI voltage is larger than internal speed limit (H07-19/H07-20), the internal speed limit is valid.

Figure 5-102 Speed limit curve when H07-17 = 1

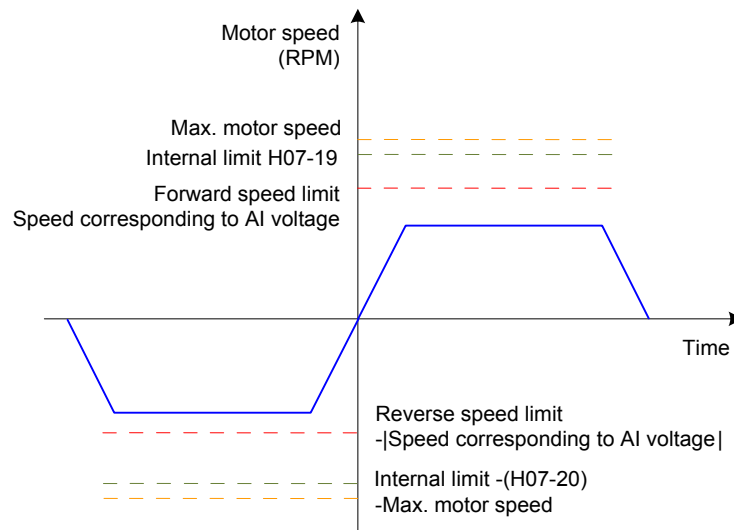

c. H07-17 = 2 (1st or 2nd speed limit selected via DI)

H07-19 or H07-20 is selected as the speed limit based on the logic of the DI signal.

To use this function, set a DI terminal of the servo drive with function 36 (FunIN.36: V-LmtSel, internal speed limit source) and set the terminal logic.

Relevant function No.:

No.	Function Symbol	Function Name	Description
FunIN.36	V_LmtSel	Internal speed limit source	Valid: H07-20 as internal speed limit Valid: H07-19 as internal speed limit

Table 5-29 Speed limit descriptions

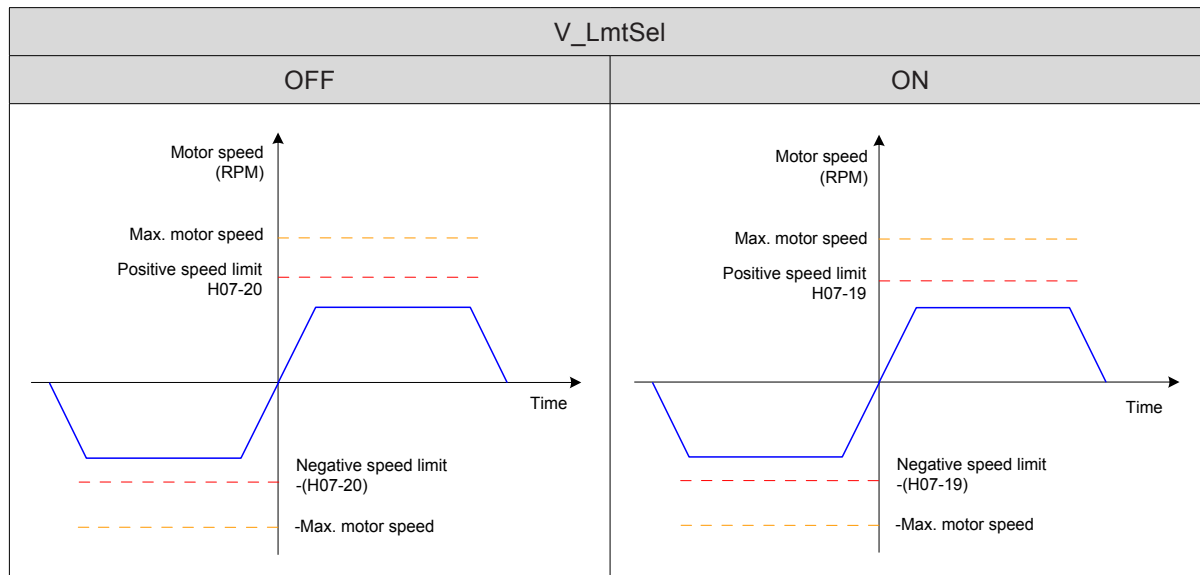

Relevant parameters:

Function Code	Parameter Name	Setting Range	Unit	Function	Property	Effective Time	Default
H07-18	V-LMT selection	1: AI1 2: AI2	-	Select the analog input channel when external analog (V-LMT) is used as the speed limit source.	Immediate	During running	1
H07-19	Positive speed limit/1st speed limit in torque control	0 to 6000	RPM	Set the positive speed limit/1st speed limit in the torque control mode.	Immediate	During running	3000
H07-20	Negative speed limit/2nd speed limit in torque control	0 to 6000	RPM	Set the positive speed limit/2nd speed limit in the torque control mode.	Immediate	During running	3000

2) Speed limit DO signal

In the torque control mode, when the actual motor speed exceeds the speed limit and the duration lasts the time of H07-40, the servo drive considers that the motor speed is limited and outputs the speed limit signal (FunOUT.8:V-LT) to the host controller. If any of the conditions is not met, the speed limit signal is invalid.

The speed limit signal (FunOUT.8:V-LT) is judged only in the torque mode and servo running status. Set a DO terminal of the servo drive with function 8 (FunOUT.8:V-LT) and set the terminal logic.

Figure 5-103 Example of speed limit DO waveform

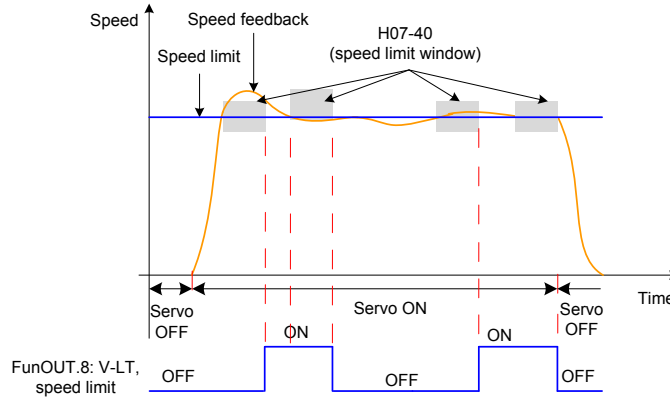

Relevant function No.:

No.	Function Symbol	Function Name	Description
FunOUT.8	V-LT	Speed limit	Invalid: Motor speed not reaching the speed limit Valid: Motor speed reaching the speed limit and speed loop built internally based on the speed limit

5.4.5 Torque Reached Output

This function is used to determine whether the actual torque reference reaches the setting range. When the actual torque reference reaches the threshold, the servo drive outputs the related DO signal (FunOUT.18: ToqReach, torque reached) to the host controller.

5

Figure 5-104 Example of torque reached output waveform

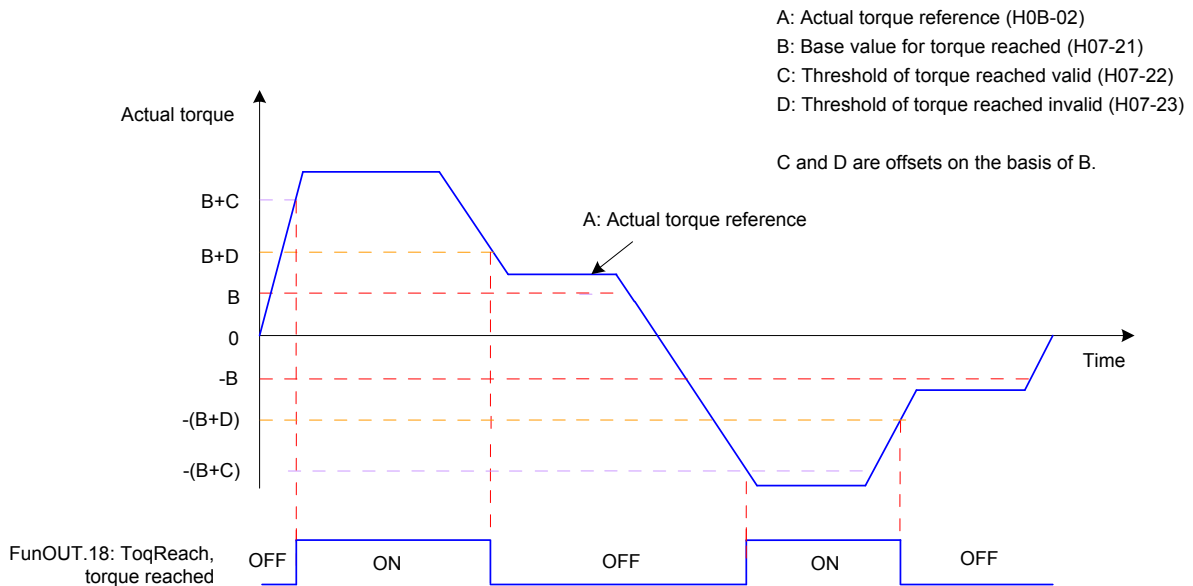

The torque reached signal becomes active when the actual torque reference meets the condition:

$$|A| \geq B + C$$

Otherwise, the torque reached signal remains inactive.

The torque reached signal becomes inactive when the actual torque reference meets the condition:

$$|A| < B + D$$

Otherwise, the torque reached signal remains active.

Figure 5-105 Torque reached output

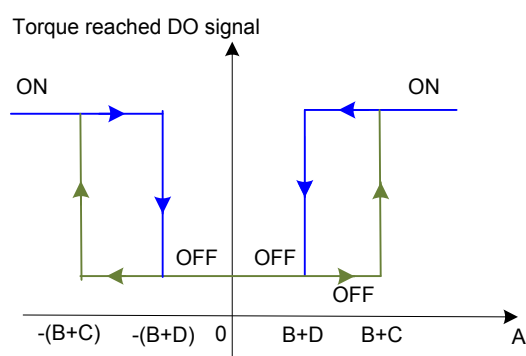

Relevant parameters:

Function Code	Parameter Name	Setting Range	Unit	Function	Property	Effective Time	Default
H07-21	Base value for torque reached	0 to 300.0	%	Set the base value for torque reached (100% corresponds to the rated torque).	During running	Immediate	0
H07-22	Threshold of torque reached valid	0 to 300.0	%	Set the offset threshold for torque reached valid (100% corresponds to the rated torque).	During running	Immediate	20.0
H07-23	Threshold of torque reached invalid	0 to 300.0	%	Set the offset threshold for torque reached invalid (100% corresponds to the rated torque).	During running	Immediate	10.0

To use the torque reached function, set a DO terminal of the servo drive with function 18 (FunOUT.18: ToqReach, torque reached) and set the terminal logic.

Relevant function No.:

No.	Function Symbol	Function Name	Description
FunOUT.18	ToqReach	Torque reached	Valid: Absolute value of torque reference reaching setting value Invalid: Absolute value of torque reference smaller than setting value

5.4.6 Function Code Block Diagram

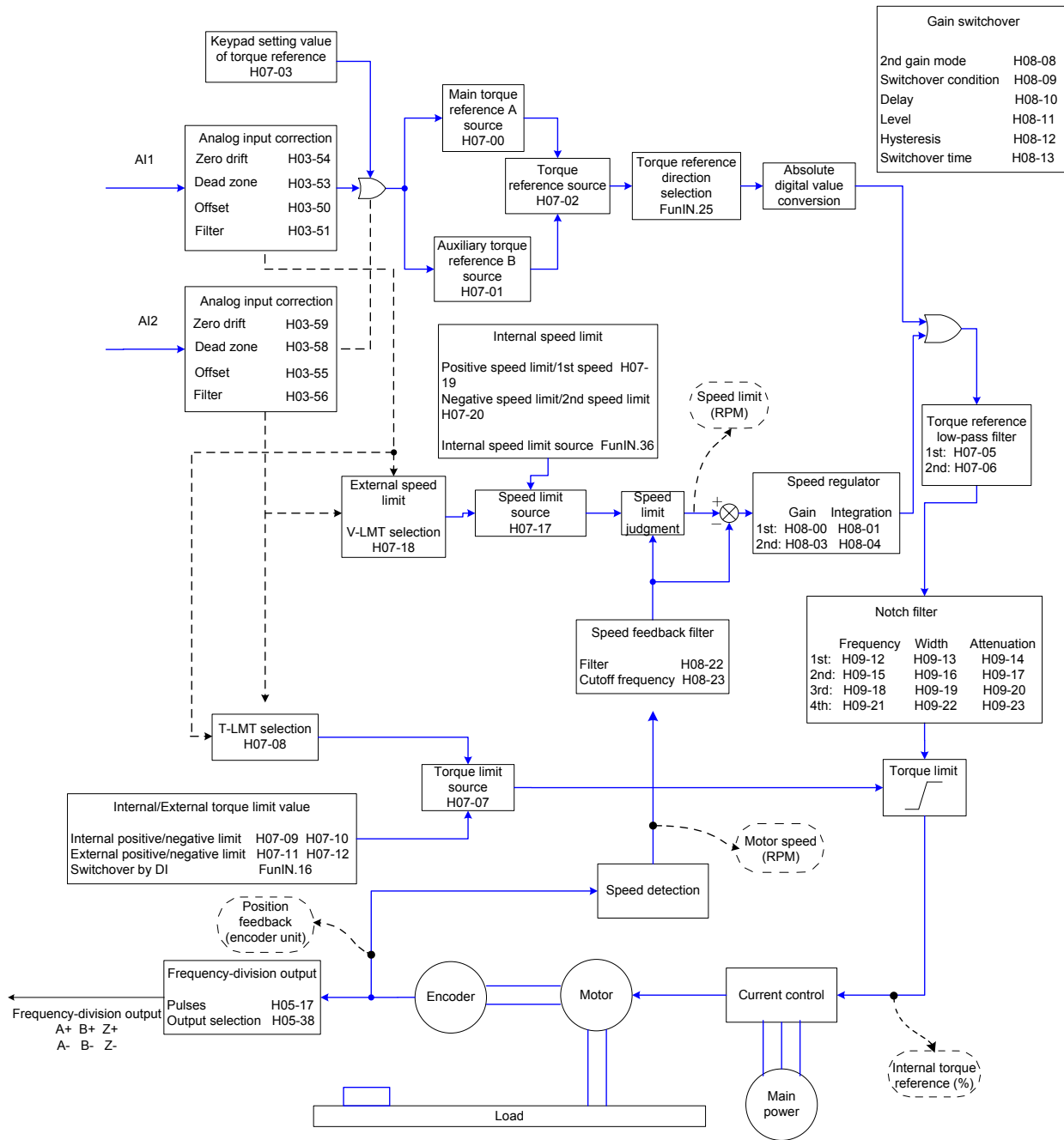

5.5 Hybrid Control Mode

The hybrid control mode means that the servo drive can switch over between different control modes when the S-ON signal is active and the servo status is "run". Switchover between the following modes is supported:

Torque mode ↔ Speed mode

Speed mode ↔ Position mode

Torque mode ↔ Position mode

Speed mode ↔ Position mode ↔ Torque mode

Set H02-00 on the keypad or Inovance servo commissioning software to implement the switchover.

Relevant parameters:

Function Code	Parameter Name	Setting Range	Function	Property	Effective Time	Default
H02-00	Control mode selection	0: Speed mode 1: Position mode 2: Torque mode 3: Torque mode/Speed mode 4: Speed mode/Position mode 5: Torque mode/Position mode 6: Torque mode/Speed mode/Position mode	Set the control mode of the servo drive.	At stop	Immediate	1

Set the servo drive parameters of different control modes based on the mechanical structure and specifications. For details, refer to Chapter 7.

H02-00 = 3/4/5: Set a DI terminal of the servo drive with function 10 (FunIN.10: M1_SEL, Mode switchover 1), and set the terminal logic.

H02-00 = 6: Set two DI terminals of the servo drive respectively with function 10 (FunIN.10: M1_SEL, Mode switchover 1) and function 11 (FunIN.11: M2_SEL, Mode switchover 2) and set the terminal logics.

Relevant function No.:

No.	Function Symbol	Function Name	Description
FunIN.10	M1_SEL	Mode switchover 1	Used to perform switchover between control modes in servo "run" status.
FunIN.11	M2_SEL	Mode switchover 2	Used to perform switchover between control modes in servo "run" status.

5.6 Descriptions of Absolute System

5.6.1 Overview

The absolute encoder consists of a detector designed to detect a position within one revolution and a cumulative revolution counter designed to detect the number of revolutions. With 8388608 (2^{23}) resolution for single turn, the encoder can record data of 16-bit multi-turn data. The absolute system composed of the absolute encoder works in absolute position linear mode or absolute position rotating mode, and can be used in position, speed, and torque control modes of the servo drive. The system keeps data battery-backed at servo drive power-off and calculates the mechanical absolute position after servo drive power-on, and therefore repeat homing operation is not required.

When using the absolute encoder, set H00-00 = 14101 (Inovance 23-bit absolute encoder) and set H02-01 (Absolute system selection) based on actual conditions. Er.731 is reported when the battery is connected for the first time. Set H0D-20 to 1 to reset the fault and perform the homing operation.

When you change H02-02 (Rotating direction selection) or H0D-20 (Absolute encoder reset), an abrupt change occurs in the encoder absolute position, causing change of the absolute position reference. Therefore, you need to perform the homing operation. When the homing function is used, the servo drive automatically calculates the deviation between the mechanical absolute position and the encoder absolute position after homing is completed and stores it in the EEPROM.

5.6.2 Relevant Parameter Setting

1) Absolute system setting

Set H00-00 to 14101 to select Inovance 23-bit absolute encoder motor, and select the absolute position mode in H02-01.

Function Code	Parameter Name	Setting Range	Function	Property	Effective Time	Default
H00-00	Motor SN	14000: Inovance 20-bit incremental encoder motor 14101: Inovance 23-bit absolute encoder motor	Select Inovance 23-bit absolute encoder motor.	At stop	Power-on again	14000
H02-01	Absolute system selection	0: Incremental position mode 1: Absolute position linear mode 2: Absolute position rotating mode	Select one absolute position mode.	At stop	Power-on again	0

In absolute position mode, the system automatically detects the motor SM to check whether absolute encoder motor is used. If the setting is incorrect, Er.122 is reported.

2) Absolute position linear mode

Function Code	Parameter Name	Setting Range	Function	Property	Effective Time	Default
H0B-07	Absolute position counter	-	It displays the current absolute position (reference unit) of the motor in absolute mode.	A display	-	0

Function Code	Parameter Name	Setting Range	Function	Property	Effective Time	Default
H0B-58	Mechanical absolute position (low 32 bits)	-	It displays the mechanical position feedback in absolute position linear or rotating mode.	At display	-	0
H0B-60	Mechanical absolute position (high 32 bits)	-		At display	-	0
H0B-77	Absolute position (low 32 bits) of absolute encoder	-	It displays the absolute position feedback from the absolute encoder.	At display	-	0
H0B-79	Absolute position (high 32 bits) of absolute encoder	-		At display	-	0

This mode is mainly applicable to the scenario where the load travel range is fixed and the encoder multi-turn data does not overflow, for example, ball screw transmission machine.

Figure 5-106 Diagram of ball screw transmission machine

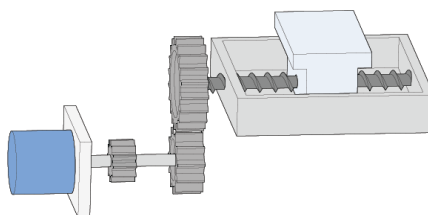

Assume that:

Mechanical absolute position (H0B-58 and H0B-60): P_M

Encoder absolute position: P_E [range: -2^{38} to $(2^{38}-1)$]

Position offset of absolute position linear mode (H05-46 and H05-48): P_O

Their relationship is: $P_M = P_E - P_O$.

Assume that the electronic gear ratio is $\frac{B}{A}$, and the mechanical absolute position (reference unit) is H0B-07, then:

$$H0B-07 = P_M / \frac{B}{A}$$

The offset of the absolute position linear mode (H05-46 and H05-48) is 0 by default. If the homing operation is performed, the servo drive automatically calculates the deviation between the encoder absolute position and the mechanical absolute position, grants values to H05-46 and H05-48, and stores the values in EEPROM.

The encoder multi-turn data range of the absolute position linear mode is -32768 to 32767. If the number of forward revolutions is larger than 32767 or the number of reverse revolutions is smaller than -32768, the servo drive trips Er. 735, indicating the encoder multi-turn overflow fault. Set H0A-36 to shield this fault.

3) Absolute position rotating mode

Function Code	Parameter Name	Setting Range	Unit	Function	Property	Effective Time	Default
H05-50	Mechanical gear ratio in absolute position rotating mode (numerator)	1 to 65535	1	Set the gear ratio between the load and the motor transmission in absolute position rotating mode. It is valid when both H05-52 and H05-53 are 0.	At stop	Immediate	65535
H05-51	Mechanical gear ratio in absolute position rotating mode (denominator)	1 to 65535	1		At stop	Immediate	1
H05-52	Pulses within one revolution of load in absolute position rotating mode (low 32 bits)	0 to 4294967295	Encoder unit	Set the pulses when the load rotates one revolution in absolute position rotating mode.	At stop	Immediate	0
H05-54	Pulses within one revolution of load in absolute position rotating mode (high 32 bits)	0 to 127	Encoder unit		At stop	Immediate	0
H0B-58	Mechanical absolute position (low 32 bits)	-	Encoder unit	Set the motor position converted from the load position in the absolute position linear or rotating mode.	At display	-	0
H0B-60	Mechanical absolute position (high 32 bits)	-	Encoder unit		At display	-	0
H0B-77	Absolute position (low 32 bits) of absolute encoder	-	Encoder unit	Set the absolute position feedback from the absolute encoder.	At display	-	0
H0B-79	Absolute position (high 32 bits) of absolute encoder	-	Encoder unit		At display	-	0
H0B-81	Rotating load single-turn position (low 32 bits)	-	Encoder unit	Set the motor position converted from the rotating load single-turn position in the absolute position rotating mode.	At display	-	0
H0B-83	Rotating load single-turn position (high 32 bits)	-	Encoder unit		At display	-	0
H0B-85	Rotating load single-turn position	-	Reference unit	Set the rotating load single-turn position in the absolute position rotating mode.	At display	-	0

This mode is mainly applicable to the scenario where the load travel range is not limited and the number of motor single-direction revolutions is smaller than 32767, as shown in the following figure.

Figure 5-107 Rotating load diagram

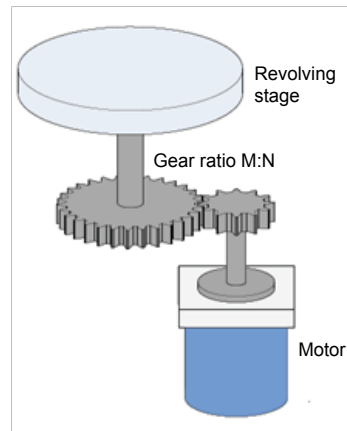

The servo drive calculates the mechanical absolute position based on H05-52 and H05-54 first. If H05-52 and H05-54 are 0, the servo drive carries out calculation based on H05-50 and H05-51. Assume that the encoder resolution $RE = 223$, and encoder pulses within one revolution of the load is RM :

When $H05-52 \neq 0$ & $H05-54 \neq 0$, $RM = H05-54 \times 232 + H05-52$;

When $H05-52 = 0$ & $H05-54 = 0$, $RM = RE$.

Assume that the electronic gear ratio is $\frac{B}{A}$, and the mechanical absolute position (reference unit) is H0B-07, then:

$$H0B-07 = RM / \frac{B}{A}$$

The following figure shows the relationship between the rotating load single-turn position and the revolving stage position.

Figure 5-108 Relationship between the rotating load single-turn position and the revolving stage position.

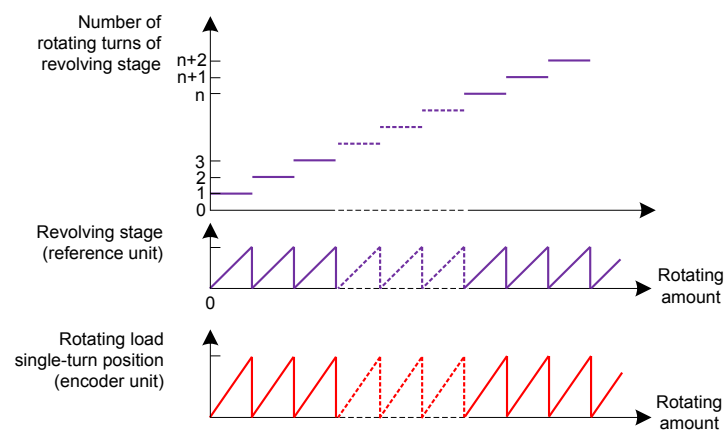

The following figure shows the relationship between the encoder feedback position and the rotating load single-turn position.

Figure 5-109 Relationship between encoder feedback position and rotating load single-turn position

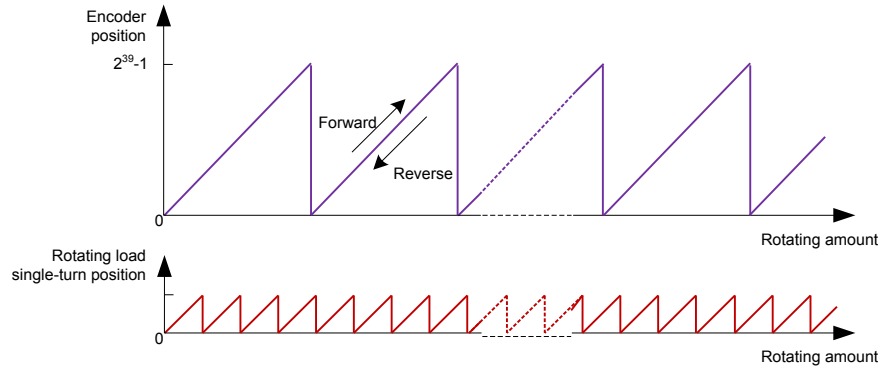

The multi-turn data range is not limited in absolute position rotating mode, and Er.735 can be shielded.

4) Encoder feedback data

Function Code	Parameter Name	Setting Range	Unit	Function	Property	Effective Time	Default
H0B-70	Number of absolute encoder turns	-	r	Display the number of absolute encoder turns.	At display	-	0
H0B-71	Position of absolute encoder within one turn	-	Encoder unit	Display the position feedback of the absolute encoder within one turn.	At display	-	0

5) Encoder multi-turn overflow fault selection

In absolute position linear mode, set H0A-36 to shield the encoder multi-turn overflow fault.

5

Function Code	Parameter Name	Setting Range	Unit	Function	Property	Effective Time	Default
H0A-36	Encoder multi-turn overflow fault selection	0: Not shield fault 1: Shield fault	-	Set whether to shield the encoder multi-turn overflow fault.	At stop	Immediate	0

6) Absolute encoder reset

Set H0D-20 to determine whether to reset the encoder internal faults and encoder feedback multi-turn data.

Function Code	Parameter Name	Setting Range	Unit	Function	Property	Effective Time	Default
H0D-20	Absolute encoder reset function	0: Disabled 1: Reset faults 2: Reset faults and multi-turn data	-	Set whether to reset the encoder internal faults and encoder feedback multi-turn data.	At stop	Immediate	0

When after you set H0D-20 to 2 and the faults and multi-turn data are reset, an abrupt change occurs in the encoder absolute position, and you need to perform the homing operation.

5.6.3 Precautions of Battery Box

Er.731 (encoder battery failure) occurs when the battery is connected for the first time. Set H0D-20 to 1 to reset the fault and perform the homing operation.

When the detected battery voltage is smaller than 3.0 V, Er.730 (encoder battery warning) occurs. Replace the battery as follows:

Step 1. Power on the servo drive, and make it in non-running state.

Step 2. Replace the battery.

Step 3. The servo drive automatically resets Er.730. If there is no other warning, run the servo drive in normal state.

After power-off of the servo drive, if you replace the battery and power on the servo drive again, Er.731 occurs and an abrupt change occurs in the multi-turn data. Set H0D-20 to 1 to reset the fault and perform the homing operation again.

During power-off of the servo drive, ensure the maximum motor speed does not exceed 6000 RPM so that the encoder position can be recorded correctly.

Store the battery in required temperature and ensure reliable contact and sufficient electricity. Failure to comply may cause loss of the encoder position.

5.6.4 Soft Limit Function

Traditional hardware limit function:

This function is implemented by inputting the external sensor signal to the CN1 terminal of the servo drive.

Figure 5-110 Installation diagram of limit switch

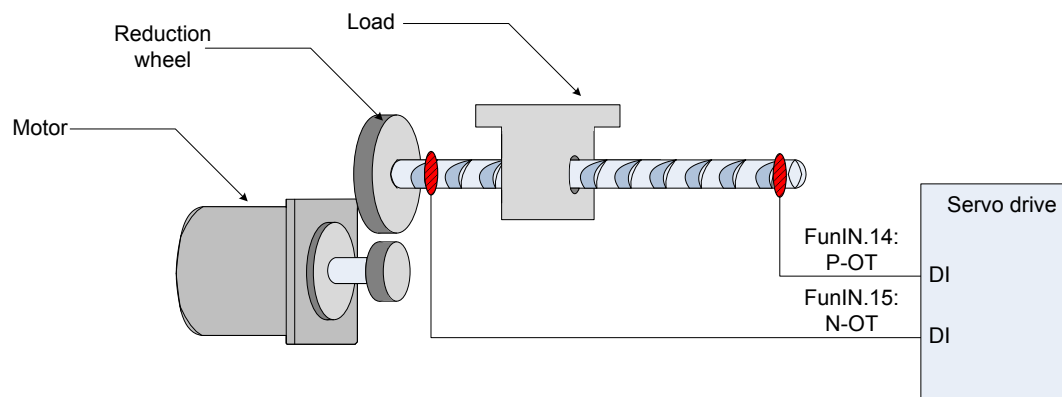

5

Soft limit function:

The servo drive compares the internal position feedback with the limit position, and alarms and stops when determining that the motor exceeds the limit position. This function is supported both in absolute position mode and incremental position mode.

In the incremental position mode, set H0A-40 to 2, and the servo drive carries out homing to find the mechanical home after power-on and then starts the soft limit function.

The following table compares the traditional hardware limit function and soft limit function.

Traditional Hardware Limit Function		Soft limit function	
1	Restricted to linear movement and single-turn rotating movement.	1	Applicable to linear movement and rotating movement
2	External mechanical limit switch required	2	Not requiring hardware, eliminating malfunction due to poor wiring contact
3	Cannot judge mechanical slip	3	Preventing mechanical slip and abnormal action with internal position comparison
4	Cannot judge or alarm machine out of limit position after power-off		

Relevant parameters of soft limit function

Function Code	Parameter Name	Setting Range	Unit	Function	Property	Effective Time	Default
H0A-40	Soft limit function	0 to 2	1	H0A-40 = 0: Soft limit function disabled	At stop	Immediate	0
H0A-41	Soft limit maximum value	-2147483648 to 2147483647	Reference unit	H0A-40 = 1: Soft limit function enabled immediately at power-on When the absolute position counter (H0B-07) is larger than H0A-41, the servo drive reports warning Er.950 and executes stop at forward limit. When the absolute position counter (H0B-07) is smaller than H0A-42, the servo drive reports warning Er.952 and executes stop at reverse limit.	At stop	Immediate	2147483647
H0A-42	Soft limit minimum value	-2147483648 to 2147483647	Reference unit	H0A-40 = 2: Soft limit function enabled after homing at power-on When the absolute position counter (H0B-07) is larger than H0A-41 after homing is completed, the servo drive reports warning Er.950 and executes stop at forward limit. When the absolute position counter (H0B-07) is smaller than H0A-42 after homing is completed, the servo drive reports warning Er.952 and executes stop at reverse limit.	At stop	Immediate	-2147483648

5.7 Auxiliary Functions

The servo drive provides the following auxiliary functions to ensure proper running of the system.

5.7.1 Software Reset

When a fault (not NO.1 non-resettable fault) occurs in the non-running state, the servo drive needs to be powered off and then powered on again but the field does not permit power-off; in this case, you can use the software reset function.

Relevant parameters:

Function Code	Parameter Name	Setting Range	Function	Property	Effective Time	Default
H0D-00	Software reset	0: Disabled 1: Enabled	The servo drive automatically performs program reset (similar to program reset at power-on) without requiring power-off/on again.	At stop	Immediate	0

5.7.2 Motor Protection

1) Motor overload protection

After being energized, the servo motor generates heat and releases it to surrounding environment due to the thermal effect of current. The servo drive provides motor overload protection to protect the motor against damage due to high temperature when the heat generated exceeds the heat released.

Set the motor overload protection gain (H0A-04) to adjust the report time of fault Er.620. Use the default value of H0A-04. Modify H0A-04 based on the actual motor heating situation when one of the following condition occurs:

The servo motor works in an environment of high temperature.

The servo motor keeps cyclic running with short time of single cycle and frequent acceleration/deceleration.

Motor overload detection can be shielded (H0A-26 = 1) when you ensure that the motor will not be damaged.



CAUTION

Take caution when using the motor overload shielding function as it may easily lead to motor damage.

Relevant parameters:

Function Code	Parameter Name	Setting Range	Unit	Function	Property	Effective Time	Default
H0A-04	Motor overload protection gain	50 to 300	%	Set the motor overload duration before Er.620 is detected out.	At stop	Immediate	100
H0A-26	Motor overload shielding	0: Not shield 1: Shield	-	Set whether to shield motor overload detection (Er.620 and Er.909).	At stop	Immediate	0

2) Locked rotor over-temperature protection

The servo drive provides overtemperature protection to protect the motor against damage due to high temperature caused by serious motor heating when the duration of rotor locked (the motor speed is almost 0 and the actual current is very large) exceeds the permissible time.

Set the time threshold for locked rotor over-temperature protection (H0A-32) to adjust the report time of Er.630. Set H0A-33 to determine whether to enable the protection function (enabled by default).



Take caution when determining to shield motor locked rotor over-temperature protection as it may easily lead to motor damage.

Relevant parameters:

Function Code	Parameter Name	Setting Range	Unit	Function	Property	Effective Time	Default
H0A-32	Time threshold for locked rotor over-temperature protection	10 to 65535	ms	Set the time duration of locked-rotor over-temperature (Er.630) before it is detected by the servo drive	During running	Immediate	200
H0A-33	Locked rotor over-temperature protection	0: Shield detection 1: Enable detection	-	Set whether to enable detection of locked rotor over-temperature protection (Er.630).	During running	Immediate	1

3) Motor overspeed protection

A very large speed causes damage to the motor or machine. The servo drive provides motor overspeed protection.

5

$$\text{Overspeed fault threshold} = \begin{cases} \text{Max. motor speed} \times 1.2 & \text{H0A-08} = 0 \\ & \text{or H0A-08} > \text{Max. motor speed} \times 1.2 \\ \text{H0A-08} & \text{H0A-08} \neq 0 \text{ and} \\ & \text{H0A-08} < \text{Max. motor speed} \times 1.2 \end{cases}$$



The servo drive also provides motor runaway protection to prevent the situation where the motor is out of control and stall occurs.

In the applications where the motor drives vertical axis or is driven by load, set H0A-12 to 0 to disable runaway fault detection. Use this setting with caution.

Relevant parameters:

Function Code	Parameter Name	Setting Range	Unit	Function	Property	Effective Time	Default
H0A-08	Overspeed threshold	0 to 10000	RPM	Set the motor speed threshold at which the overspeed fault is detected.	During running	Immediate	0
H0A-12	Runaway protection function	0: Disabled 1: Enabled	-	Set whether to enable the runaway protection function.	During running	Immediate	1

Besides runaway protection, the servo drive allows you to set the speed limit in speed control mode and torque control mode to protect the motor and machine.

5.7.3 DI Filter Time

The servo drive provides nine DI terminals, in which DI1 to DI7 are common low-speed DI terminals, and DI8 and DI9 are high-speed DI terminals.

The following table describes the signal logic of low-speed DI terminals.

Table 5-30 Signal logic of low-speed DI terminals

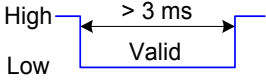
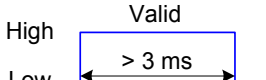
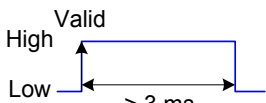
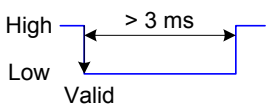
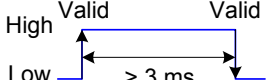
Value	Terminal Logic When DI Function Valid	Diagram
0	Low level	
1	High level	
2	Rising edge	
3	Falling edge	
4	Rising edge and falling edge	

The following table describes the signal logic of high-speed DI terminals.

Table 5-31 Signal logic of high-speed DI terminals

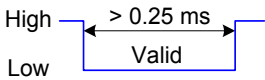
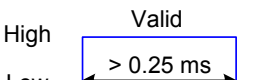
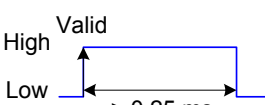
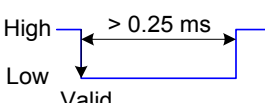
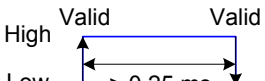
Value	Terminal Logic When DI Function Valid	Remark
0	Low level	
1	High level	
2	Rising edge	
3	Falling edge	
4	Rising edge and falling edge	

1) S-ON signal filter setting

Set a DI terminal (hardware DI or VDI) with function 1 (FunIN1: S-ON, servo ON).

If signal interference exists in this terminal, set the filter in H02-18. Note that the time width of the S-ON signal must be larger than (H02-18) + 3 ms. Otherwise, this signal is invalid.

2) High-speed DI terminal filter setting

Set the filter of two high-speed DI terminals (maximum frequency 4 kHz) in H0A-19 and H0A-20.

Relevant parameters:

Function Code	Parameter Name	Setting Range	Unit	Function	Property	Effective Time	Default
H02-18	Filter time of S-ON signal	0 to 64	ms	Set the filter time constant of the S-ON signal.	At stop	Immediate	0
H0A-19	D18 filter time constant	0 to 255	25 ns	Set the filter time constant of high-speed D18 terminal.	At stop	Power-on again	80
H0A-20	D19 filter time constant	0 to 255	25 ns	Set the filter time constant of high-speed D19 terminal.	At stop	Power-on again	80



6 Adjustment

6.1 Overview	266
6.2 Inertia Auto-tuning	268
6.2.1 Offline Inertia Auto-tuning	269
6.2.2 Online Inertia Auto-tuning	272
6.3 Automatic Gain Tuning	273
6.4 Manual Gain Adjustment	276
6.4.1 Basic Parameters	276
6.4.2 Gain Switchover	279
6.4.3 Filter Comparison	285
6.4.4 Feedforward Gain	285
6.4.5 Pseudo-Differential Feedforward Control	288
6.4.6 Torque Disturbance Observer	289
6.5 Parameter Adjustment in Different Control Modes	290
6.5.1 Parameter Adjustment in Position Control Mode	290
6.5.2 Parameter Adjustment in Speed Control Mode	292
6.6 Vibration Suppression	292
6.6.1 Suppression of Mechanical Resonance	292
6.6.2 Suppression of Low-frequency Resonance	298

Chapter 6 Adjustment

6.1 Overview

The servo drive is required to run the motor in least time delay and as faithful as possible against references from the host controller or internal setting. Gain adjustment needs to be performed to meet the requirements.

Figure 6-1 Gain setting example

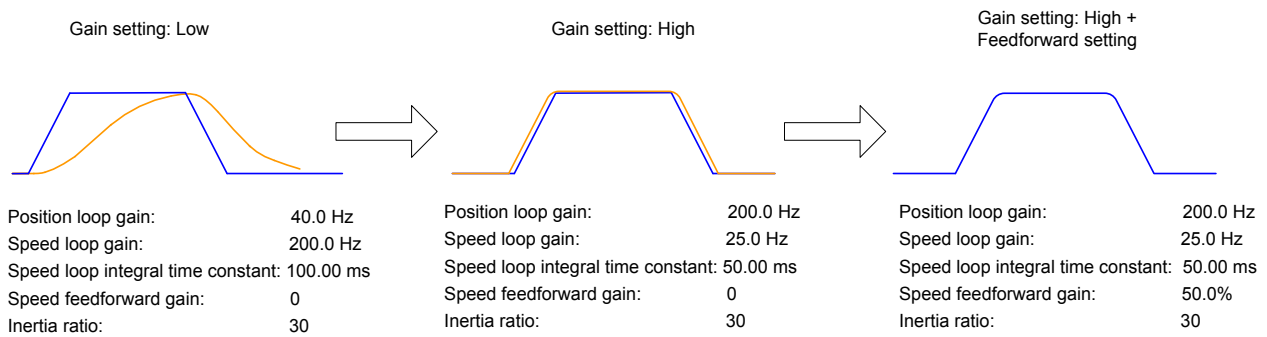

Servo gain is adjusted by setting multiple parameters (including position loop gain, speed loop gain, filter and inertia ratio) that affect each other. Ensure these parameters have a balanced relationship during setting.



CAUTION

Before gain adjustment, perform jog running and ensure the motor is under normal operation.

The following figure shows the general gain adjustment flowchart.

Figure 6-2 Gain adjustment flowchart

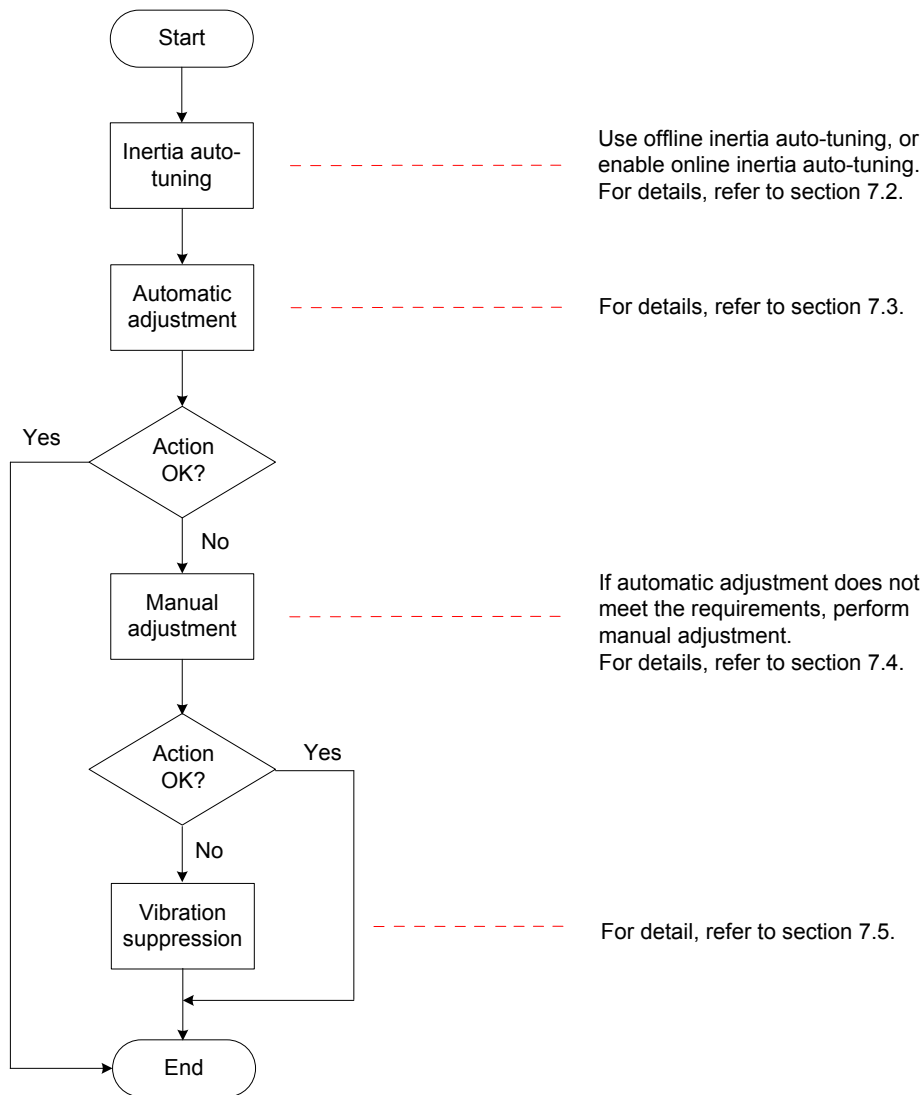

Table 6-1 Descriptions of gain adjustment procedure

Gain Adjustment Procedure			Function	Section to Refer
1	Inertia auto-tuning	Offline	The drive calculates the inertia ratio automatically.	6.2.1
		Online	The host controller sends a command to make the motor rotate, and the drive calculates the inertia ratio in real time.	6.2.2
2	Automatic gain adjustment		The drive automatically gives the gain parameters matching the inertia ratio (it must be set correctly).	6.3

Gain Adjustment Procedure		Function	Section to Refer	
3	Manual gain adjustment	Basic	If the automatic gain adjustment result is not satisfactory, perform fine manual adjustment.	6.4
		Reference filter	Filter the position, speed, and torque references.	6.4.3
		Feedforward gain	Enable this function to improve the follow-up characteristics.	6.4.4
		Pseudodifferential regulator	Adjust the speed loop control mode and improve the low-frequency anti-interference capability.	6.4.5
		Torque disturbance observer	Enable this function to improve the anti-torque disturbance capability.	6.4.6
4	Vibration suppression	Mechanical resonance	Enable the notch function to suppress mechanical resonance.	6.5.1
		Low-frequency resonance	Enable the filter for suppressing low-frequency resonance.	6.5.2

6.2 Inertia Auto-tuning

The inertia ratio (H08-15) is:

$$\text{Inertia ratio} = \frac{\text{Total load inertia of machine}}{\text{Motor rotor inertia}}$$

The inertia ratio is an important parameter of the servo system, and quick commissioning can be implemented with the correct setting of this parameter.

It can be set manually or auto-tuned automatically by the servo drive.

The servo drive supports two auto-tuning methods:

1) Offline auto-tuning

When the offline inertia auto-tuning function is enabled in H0D-02, press the keys on the keypad of the servo drive to run the motor and obtain the inertia ratio. This method does not involve the host controller.

2) Online auto-tuning

The servo drive instructs the motor to act according to the command from the host controller, obtaining the inertia ratio.



The following requirements must be met to ensure correct calculation of the inertia ratio:

- The actual maximum motor speed is larger than 150 RPM.
- The actual acceleration rate during acceleration/deceleration is higher than 3000 RPM/s.
- The load torque is stable without dramatic change.
- The actual inertia ratio does not exceed 120.

If the actual inertia ratio is very large and the drive gain is low, motor action will be slow, which cannot meet the requirements for maximum motor speed and actual acceleration rate. In this case, increase the speed loop gain in H08-00 and perform inertia auto-tuning again.

If vibration occurs during auto-tuning, stop auto-tuning immediately and decrease the gain.

The auto-tuning may fail when the backlash of the transmission mechanism is large.

6.2.1 Offline Inertia Auto-tuning

Confirm the following items before performing offline auto-tuning:

1) The movement travel of the motor meet the following requirements:

a. The movement travel of above one revolution in either forward or reverse direction is available between the mechanical limit switches.

Ensure the limit switches have been installed and the required movement travel is reserved to prevent the condition that the motor senses the limit switches, causing accidents during auto-tuning.

b. H09-09 (Motor revolutions for an inertia auto-tuning) is met:

View the maximum speed, acceleration time, and motor revolutions for inertia auto-tuning in H09-06, H09-07, and H09-09. Ensure the movement travel for the motor in the stop position is larger than H09-09; if not, decrease H09-06 or H09-07 until the requirements are met.

2) Evaluate the value of H08-15.

If the default value of H08-15 (1.00) is used but the actual inertia ratio is 30.00, the motor may run very slowly, resulting in auto-tuning failure. To solve this problem, take the following measures:

a. Preset a large initial value for H08-15.

The recommended preset value is 5.00.

Increase H08-15 gradually, and record the value updated on the keypad (the keypad display updates if auto-tuning succeeds).

It is suggested that you perform auto-tuning several times and take the average value.

b. Increase the stiffness level of the drive in H09-01 properly so that the actual motor speed can reach H09-06.

The following figure shows the offline inertia auto-tuning flowchart.

Figure 6-3 Offline inertia auto-tuning flowchart

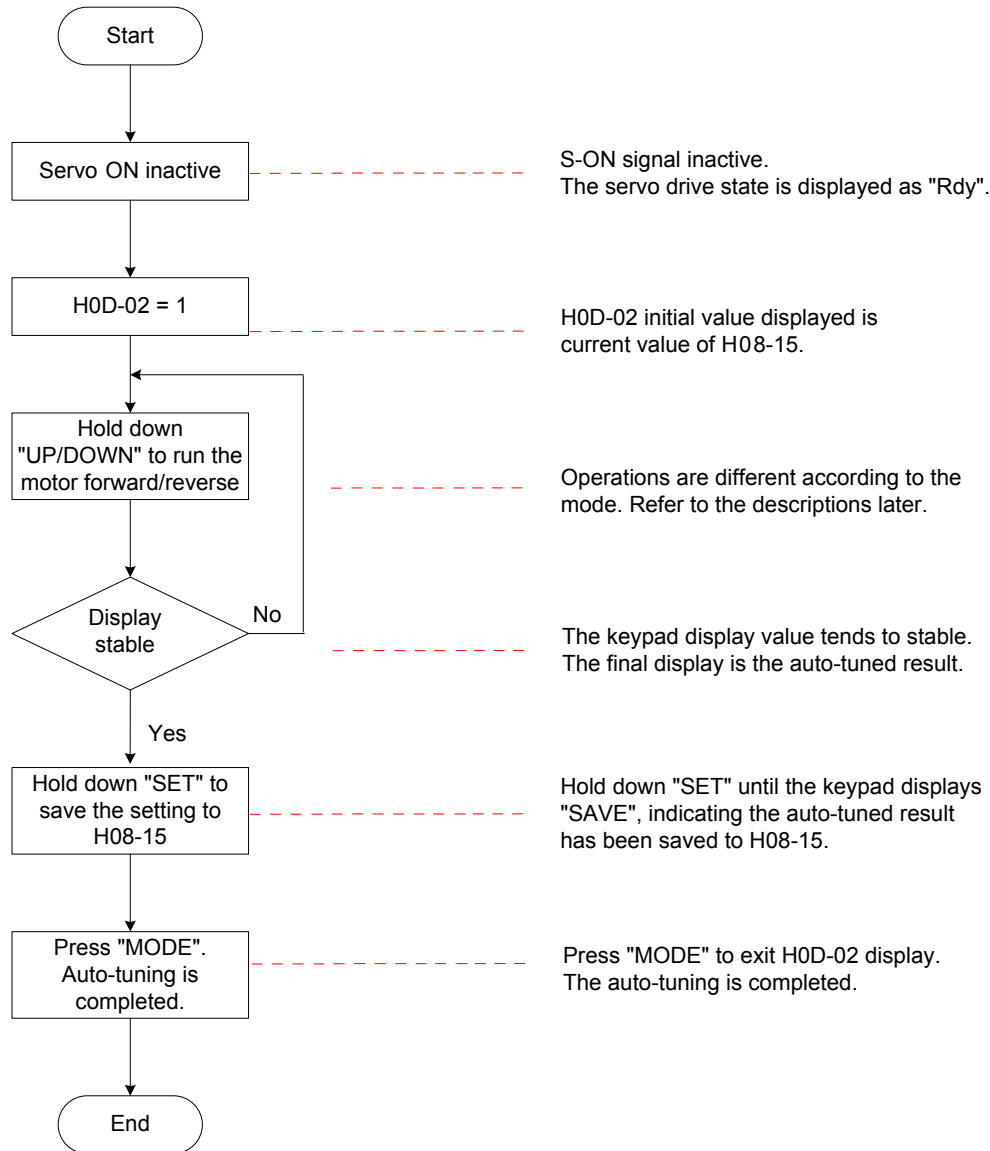

6

Offline inertia auto-tuning includes two modes: positive/negative triangle wave and jog. The two modes have different reference forms.

Table 6-2 Descriptions of two offline inertia auto-tuning modes

Item	Positive and Negative Triangular Wave Mode (H09-05 = 0)	Jog mode (H09-05 = 1)
Reference form	<p>Symmetric triangle wave</p>	<p>Trapezoidal wave</p>
Maximum speed	H09-06	H09-06

Item	Positive and Negative Triangular Wave Mode (H09-05 = 0)	Jog mode (H09-05 = 1)
Acceleration/ Deceleration time	H09-07	H09-07
Keypad operation	Hold down key UP: The motor rotates forward and then reverse. Hold down key DOWN: The motor rotates reverse and then forward. Release the key: The motor stops at zero speed and enters in position lock state.	Press key UP: The motor rotates forward. Press key DOWN: The motor rotates reverse. Release the key: The motor stops at zero speed and enters in position lock state.
Interval	H09-08	Interval between two key operations
Motor revolutions	≤ H09-09	Manual control
Application	Application where the motor travel is short	Application where the motor travel is long and manual control is allowed

Relevant parameters:

Function Code	Parameter Name	Setting Range	Unit	Description	Property	Effective Time	Default
H09-05	Offline inertia auto-tuning mode	0: Positive/ negative triangular wave mode 1: Jog mode	-	Set the offline inertia auto-tuning mode.	At stop	Immediate	0
H09-06	Maximum speed for inertia auto- tuning	100–1000	RPM	Set the maximum speed reference for offline inertia auto- tuning.	At stop	Immediate	500
H09-07	Time constant of accelerating to max. speed for inertia auto- tuning	20–800	ms	Set the time for the motor to accelerate from 0 RPM to H09- 06 in offline inertia auto-tuning.	At stop	Immediate	125
H09-08	Interval after an inertia auto- tuning	50–10000	ms	Set the interval between two consecutive speed references in positive/ negative triangle wave mode.	At stop	Immediate	800
H09-09	Motor revolutions for an inertia auto- tuning	-	r	Set the number of motor revolutions in positive/negative triangle wave mode.	-	-	250

6.2.2 Online Inertia Auto-tuning

The following figure shows the general online inertia auto-tuning flowchart.

Figure 6-4 Online inertia auto-tuning flowchart

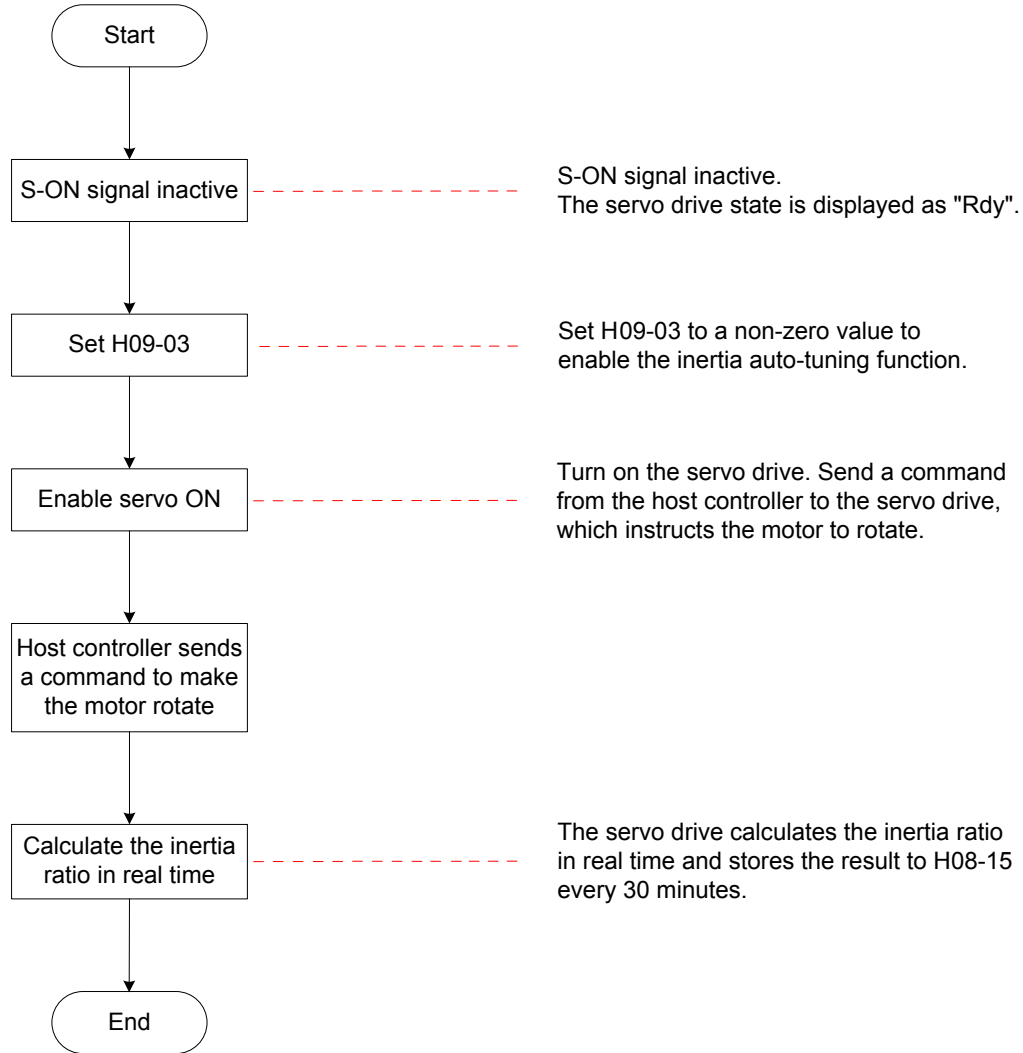

6

Note Different H09-03 values indicate different updating speeds of the inertia ratio in H08-15.

- H09-03 = 1: Applicable to the scenario where the actual inertia ratio rarely changes, such as machine tool and wood carving machine.
- H09-03 = 2: Applicable to the scenario where the inertia ratio changes slowly.
- H09-03 = 3: Applicable to the scenario where the actual inertia ratio changes rapidly, such as transportation manipulator.

Relevant parameters:

Function Code	Parameter Name	Setting Range	Unit	Description	Property	Effective Time	Default
H09-03	Online inertia auto-tuning mode	0: Disabled 1: Enabled, update slowly 2: Enabled, always update 3: Enabled, update quickly	-	Set the online inertia auto-tuning mode.	During running	Immediate	0

6.3 Automatic Gain Tuning

Automatic gain tuning means that the servo drive automatically produces the matching gain parameters based on the setting of H09-01 (Stiffness level selection) to achieve fast response and stability.



CAUTION

Ensure the correct inertia ratio has been obtained before enabling automatic gain tuning.

Figure 6-5 Automatic gain tuning flowchart

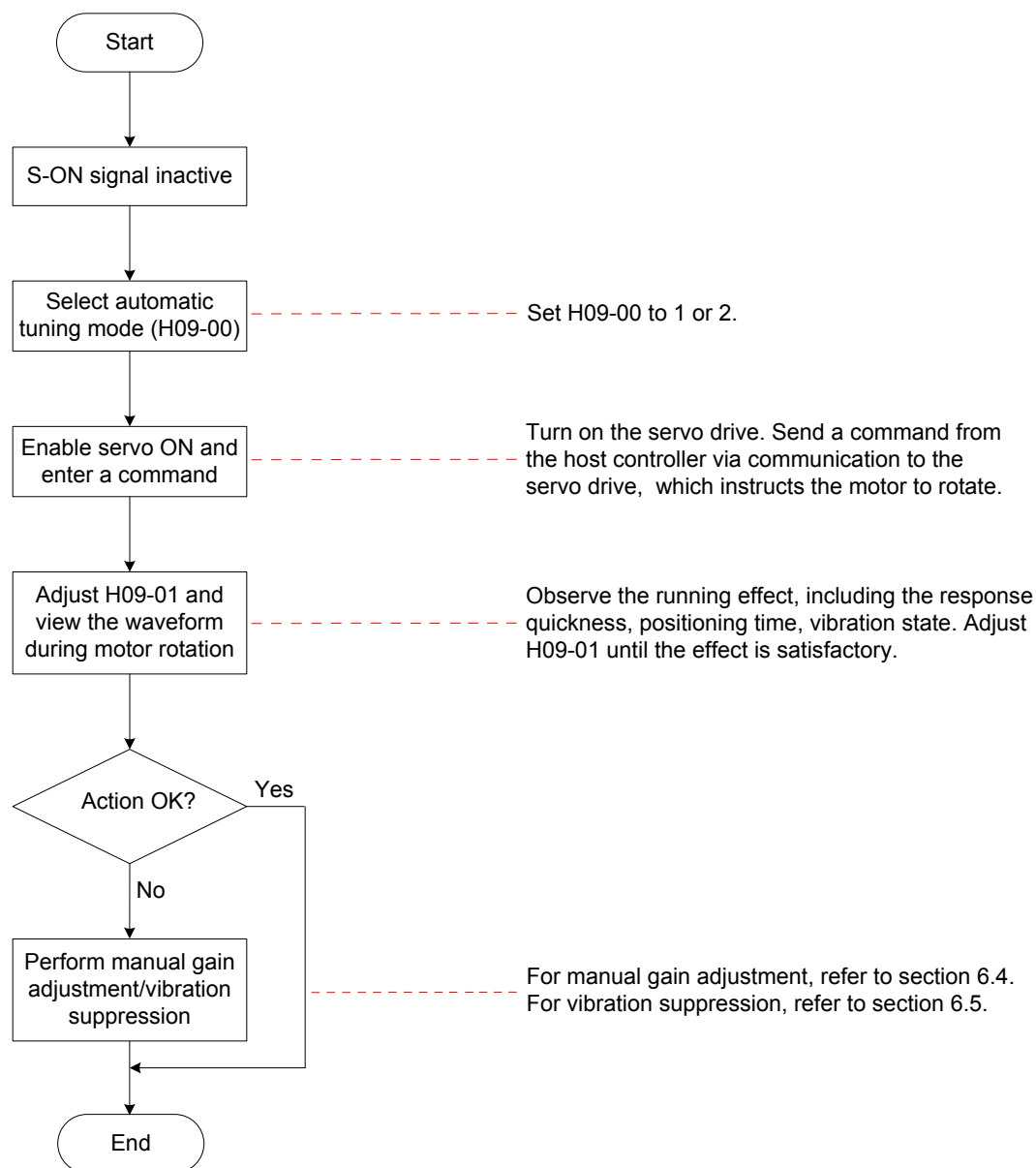

The setting range of H09-01 (Stiffness level selection) is 0–31. The level 0 indicates the weakest stiffness and lowest gain and level 31 indicates the strongest stiffness and highest gain. The following table lists the stiffness levels for different load types.

Table 6-3 Recommended stiffness levels

Recommended Stiffness Level	Type of Load Mechanism
Level 4 to level 8	Large-scale machinery
Level 4 to level 8	Applications with low stiffness such as belt
Level 15 to level 20	Applications with high stiffness such as ball screw and direct-connected motor

The servo drive supports two automatic gain adjustment modes.



CAUTION

The automatic gain tuning mode (H09-00 = 1) is applicable to most applications. In application where positioning must be very quick, use the positioning mode (H09-00 = 2).

1) Automatic gain tuning mode (H09-00 = 1)

The 1st gain parameters (H08-00 to H08-02, H07-05) are automatically updated according to the stiffness level set in H09-01 and stored into the corresponding function codes.

Table 6-4 Parameters automatically updated in the automatic gain tuning mode

Function Code	Parameter Name
H08-00	Speed loop gain
H08-01	Time constant of speed loop integration
H08-02	Position loop gain
H07-05	Time constant of torque reference filter

2) Positioning mode (H09-00 = 2)

a. On the basis of Table 6-4, the 2nd gain parameters (H08-03 to H08-05, H07-06) are also automatically updated according to the stiffness level set in H09-01 and stored into the corresponding function codes. In addition, the position loop gain in the 2nd gain parameters has a higher stiffness level than that in the 1st gain parameters.

Table 6-5 Parameters automatically updated in the positioning mode

Function Code	Parameter Name	Description
H08-03	2nd gain of speed loop	-
H08-04	2nd time constant of speed loop integration	If H08-04 is set to remain at 512.00 ms, the 2nd speed loop integral action is invalid, and only proportional control is used in the speed loop.
H08-05	2nd gain of position loop	-
H07-06	2nd time constant of torque reference filter	-

b. The parameters related to speed feedforward are fixed at certain values.

Table 6-6 Parameters with fixed values in the positioning mode

Function Code	Parameter Name	Value
H08-19	Speed feedforward gain	30.0%
H08-18	Time constant of speed feedforward filter	0.50 ms

c. The parameters related to gain switchover are fixed at certain values.

The gain switchover function is enabled automatically in the positioning mode.

Function Code	Parameter Name	Value	Description
H08-08	2nd gain mode setting	1	In the positioning mode, switchover between 1st gain (H08-00 to H08-02, H07-05) and 2nd gain (H08-03 to H08-05, H07-06) is valid. In other modes, the original setting is used.
H08-09	Gain switchover condition	10	In the positioning mode, the gain switchover condition is H08-09 = 10. In other modes, the original setting is used.
H08-10	Gain switchover delay	5.0 ms	In the positioning mode, the gain switchover delay is 5.0 ms. In other modes, the original setting is used.
H08-11	Gain switchover level	50	In the positioning mode, the gain switchover level is 50. In other modes, the original setting is used.
H08-12	Gain switchover hysteresis	30	In the positioning mode, the gain switchover hysteresis is 30. In other modes, the original setting is used.



CAUTION

In the automatic gain tuning mode, the parameters automatically updated along with H09-01 and those with fixed values do not allow modification. If you need to modify these parameters, set H09-00 to 0 to exit the automatic gain tuning mode first.

Relevant parameters:

Function Code	Parameter Name	Setting Range	Unit	Description	Property	Effective Time	Default
H09-00	Automatic gain tuning mode selection	0: Disabled, gain parameters set manually 1: Automatic gain tuning mode, gain parameters tuned automatically based on stiffness table 2: Positioning mode, gain parameters automatically tuned based on stiffness table	-	Set the automatic gain tuning mode.	During running	Immediate	0
H09-01	Stiffness level selection	0–31	-	Set the stiffness level.	During running	Immediate	12

6.4 Manual Gain Adjustment

6.4.1 Basic Parameters

When the automatic gain adjustment result is not satisfactory, execute fine manual gain adjustment to achieve better result.

The servo system consists of three control loops, namely, position loop, speed loop, and current loop from external to internal. The following figure shows the basic control block diagram.

Figure 6-6 Basic control block diagram of manual gain adjustment

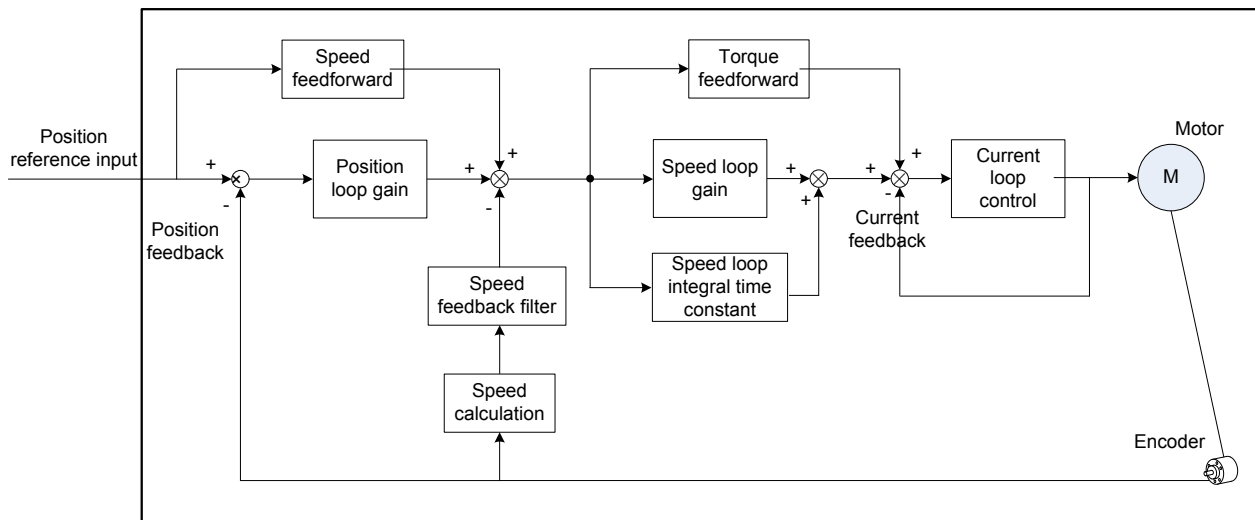

The most internal loop must have the highest response. If it is not observed, the system may be unstable.

The default current loop gain of the servo drive ensures the response, and need not be adjusted. You only need to adjust the position loop gain, speed loop gain and other auxiliary gains. When executing gain adjustment in the position control mode, increase the speed loop gain as well after increasing the position loop gain, and ensure the response of the position loop is lower than that of the speed loop to keep the system stable.

The basic gain parameters are set as follows.

Table 6-7 Descriptions of gain parameters

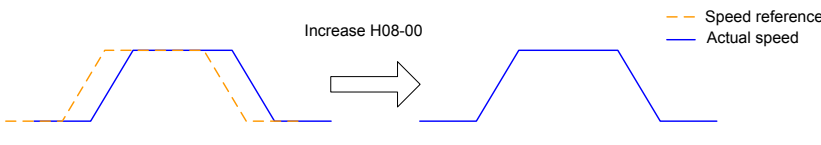
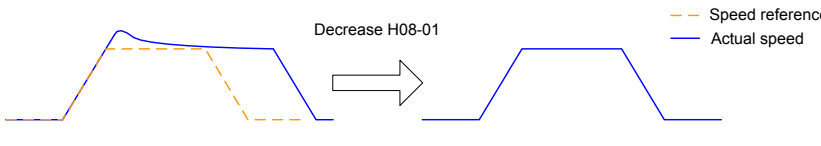
Step	Function Code	Parameter Name	Adjustment Description
1	H08-00	Speed loop gain	<p>Parameter function: It determines the speed reference maximum frequency followed by the speed loop. When the average inertia ratio (H08-15) is correct, it can be considered: Maximum follow-up frequency of speed loop = H08-00</p>  <p>Adjustment method: Increase the setting but ensure there is no noise or vibration. This shortens the positioning time and improves speed stability and follow-up characteristics. If noise occurs, decrease the setting. If mechanical vibration occurs, enable the resonance suppression function by referring to section 6.5.1.</p>
2	H08-01	Time constant of speed loop integration	<p>Parameter function: It eliminates the speed loop deviation.</p>  <p>Adjustment method: Select the value as follows: $500 \leq H08-00 \times H08-01 \leq 1000$ For example, if H08-00 = 40.0 Hz, H08-01 must meet the condition: $12.50 \text{ ms} \leq H08-01 \leq 25.00 \text{ ms}$ Decreasing the setting strengthens the integral effect and shortens the positioning time, but a very small setting may cause mechanical vibration. A very large setting may cause the homing action under the speed loop deviation. When H08-01 = 512.00 ms, the integral action is invalid.</p>

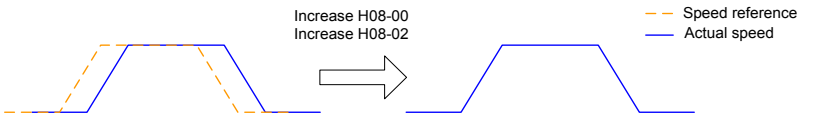
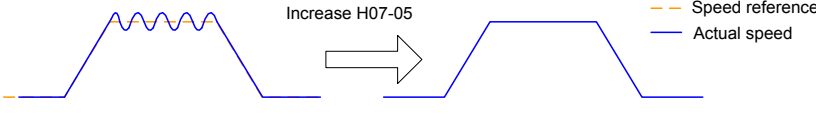
Step	Function Code	Parameter Name	Adjustment Description
3	H08-02	Position loop gain	<p>Parameter function: It sets the position reference maximum frequency followed by the position loop. Maximum follow-up frequency of position loop = H08-02</p>  <p>Adjustment method: To ensure system stability, the maximum follow-up frequency of the speed loop is 3 to 5 times of the maximum follow-up frequency of the position loop.</p> $3 \leq \frac{2 \times \pi \times H08-00}{H08-02} \leq 5$ <p>For example, when H08-00 = 40.0 Hz, H08-02 must meet the condition: 50.2 Hz ≤ H08-02 ≤ 83.7 Hz</p> <p>Adjust the setting based on the positioning time. Increasing the setting shortens the acceleration time and improves the motor capability of against external disturbance in static state.</p> <p>A very large setting may cause system instability and oscillation.</p>
4	H07-05	Time constant of torque reference filter	<p>Parameter function: It eliminates high-frequency noise and suppresses mechanical resonance.</p>  <p>Adjustment method: Ensure the cutoff frequency of the torque reference low-pass filter is higher than 4 times of the maximum follow-up frequency of the speed loop.</p> $\frac{1000}{2 \times \pi \times H07-05} \geq (H08-00) \times 4$ <p>For example, when H08-00 = 40.0 Hz, H07-05 must meet the condition: H07-05 ≤ 1.00 ms</p> <p>If vibration occurs when increasing H08-00, adjust the setting of H07-05 to suppress vibration. For details, refer to section 7.5.1.</p> <p>A very large setting weakens the response of the current loop.</p> <p>To suppress vibration when the motor is stopping, increase H08-00 and decrease H07-05. To suppress vibration when the motor is in the stopped state, decrease H07-05.</p>

Relevant parameters:

Function Code	Parameter Name	Setting Range	Unit	Description	Property	Effective Time	Default
H08-00	Speed loop gain	0.1–2000.0	Hz	Set the proportional gain of the speed loop.	During running	Immediate	25.0
H08-01	Time constant of speed loop integration	0.15–512.00	ms	Set the integral time constant of the speed loop.	During running	Immediate	31.83
H08-02	Position loop gain	0.0–2000.0	Hz	Set the proportional gain of the position loop.	During running	Immediate	40.0
H07-05	Time constant of torque reference filter	0.00–30.00	ms	Set the filter time constant of the torque reference.	During running	Immediate	0.79

6.4.2 Gain Switchover

By selecting appropriate gain based on the servo internal state or external DI signal (supported only in position and speed control modes), the following effect can be achieved:

- Switchover to lower gain in motor static state (servo ON) to suppress vibration
- Switchover to higher gain in motor static state to shorten the positioning time
- Switchover to higher gain in motor running state to achieve better reference compliance performance
- Switchover between different gains is performed based on the load condition

1) H08-08 = 0:

The gain used is fixed at the 1st gain (H08-00 to H08-02, H07-05), but switchover between proportional control and proportional & integral control via DI function 3 ((FunIN.3: GAIN_SEL, gain switchover) is supported for the speed loop.

Figure 6-7 Gain switchover flowchart when H08-08 = 0

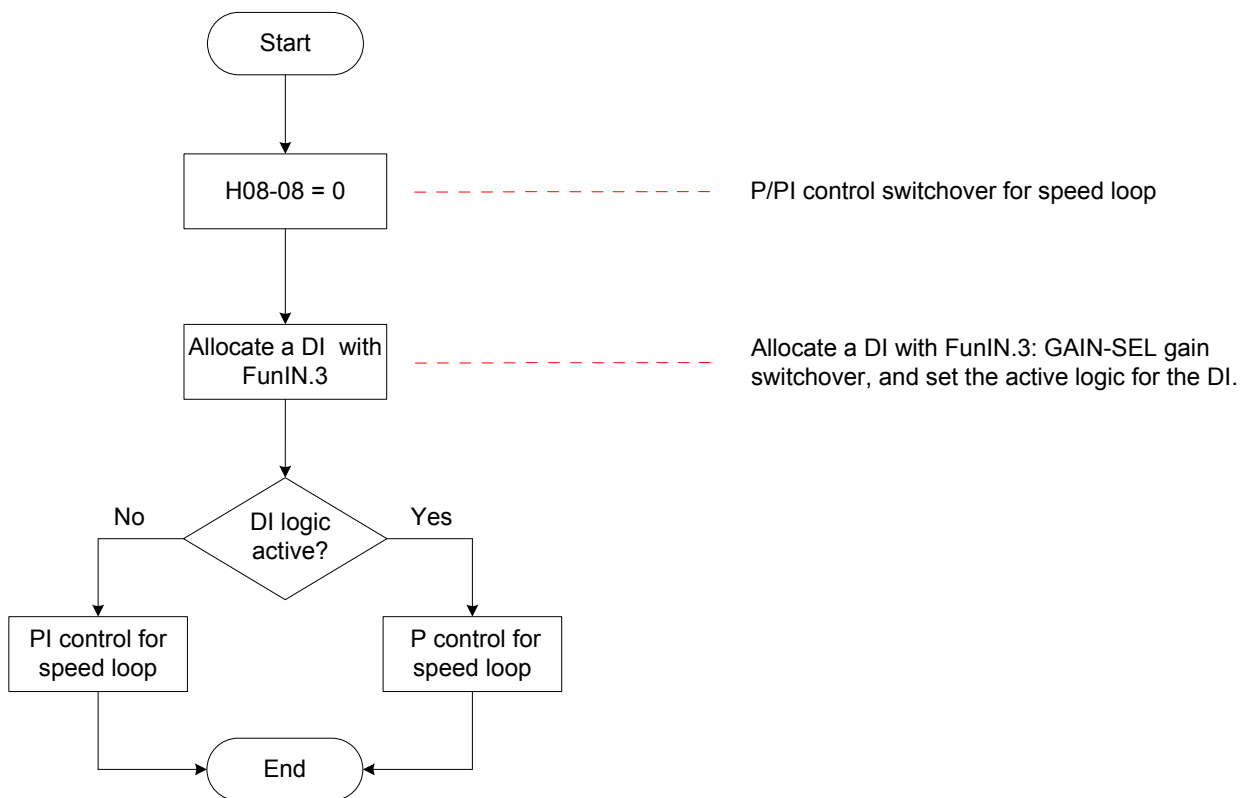

2) H08-08 = 1:

Switchover between 1st gain (H08-00 to H08-02, H07-05) and 2nd gain (H08-03 to H08-05, H07-06) is implemented based on the setting of H08-09.

Figure 6-8 Gain switchover flowchart when H08-08 = 1

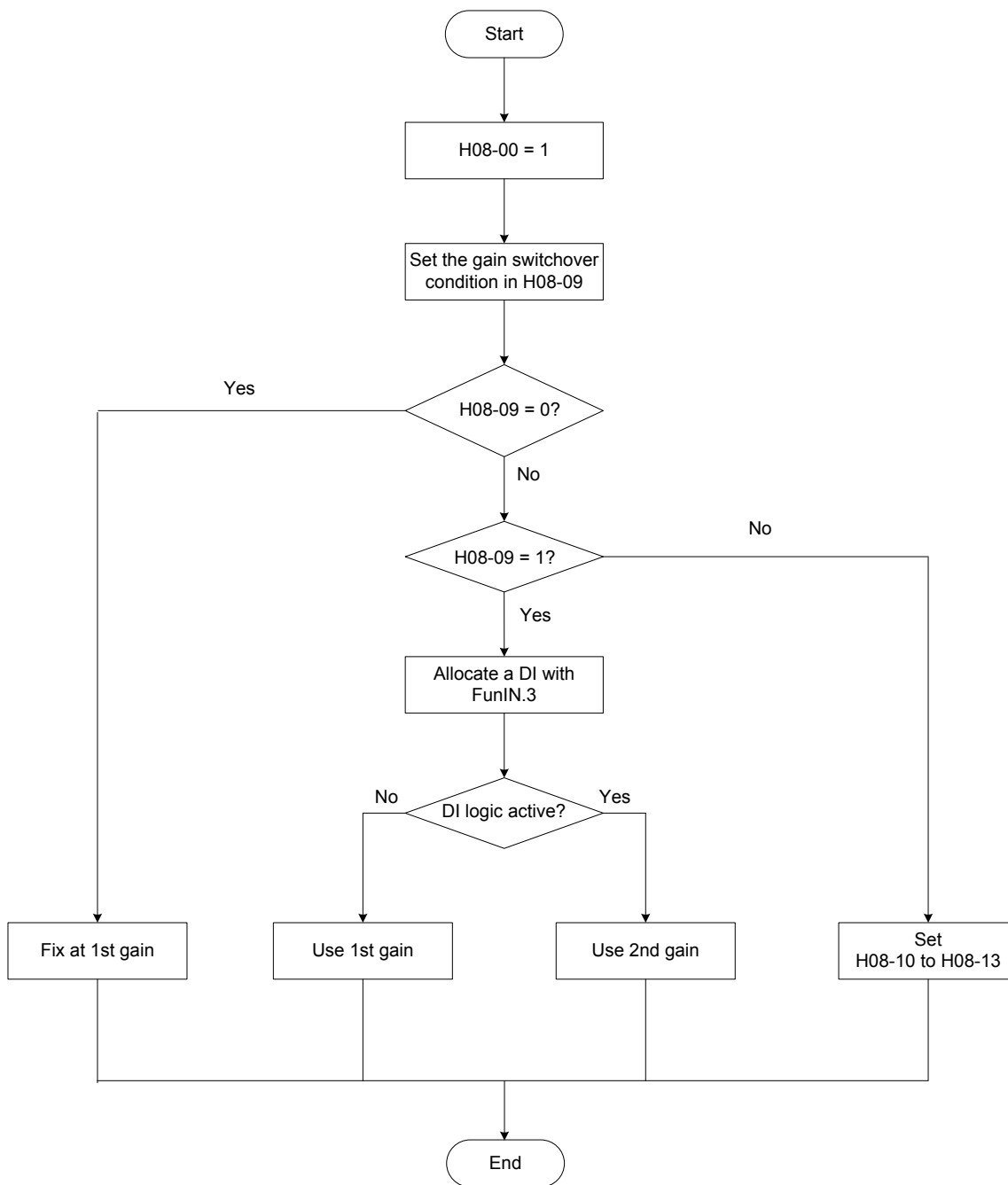

6

Gain switchover has 11 conditions. The following table describes the diagrams and relevant parameters of different conditions.

Table 6-8 Descriptions of gain switchover conditions

Gain Switchover Condition			Relevant Parameters		
H08-09	Condition	Diagram	Gain switchover delay (H08-10)	Gain switchover level (H08-11)	Gain switchover hysteresis (H08-12)
0	Fixed at 1st gain	-	Invalid	Invalid	Invalid
1	Switchover by DI	-	Invalid	Invalid	Invalid

Gain Switchover Condition			Relevant Parameters		
H08-09	Condition	Diagram	Gain switchover delay (H08-10)	Gain switchover level (H08-11)	Gain switchover hysteresis (H08-12)
2	Torque reference being large		Valid	Valid (%)	Valid (%)
3	Speed reference being large		Valid	Valid	Valid
4	Speed reference change rate being large		Valid	Valid (10 RPM/s)	Valid (10 RPM/s)
5	Speed reference high-speed/ low-speed thresholds		Invalid	Valid (RPM)	Valid (RPM)
6	Position deviation being large		Valid	Valid (encoder unit)	Valid (encoder unit)

6

Gain Switchover Condition			Relevant Parameters		
H08-09	Condition	Diagram	Gain switchover delay (H08-10)	Gain switchover level (H08-11)	Gain switchover hysteresis (H08-12)
7	Position reference available		Valid	Invalid	Invalid
8	Positioning completion		Valid	Invalid	Invalid
9	Motor speed being large		Valid	Valid (RPM)	Valid (RPM)
10	Position reference available + Motor speed	See the "Note".	Valid	Valid (RPM)	Valid (RPM)



H08-10 is valid only when 2nd gain is switched over to 1st gain.

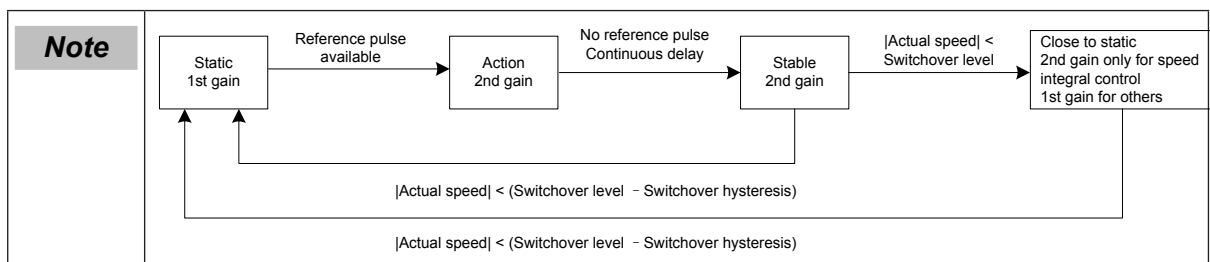

Relevant parameters:

Function Code	Parameter Name	Setting Range	Unit	Description	Property	Effective Time	Default
H08-08	2nd gain mode setting	0: 1st gain fixed, P/PI switchover by DI 1: Gain switchover based on H08-09	-	Set the mode of the 2nd gain.	During running	Immediate	1
H08-09	Gain switchover condition	0: 1st gain fixed 1: Switchover by DI 2: Torque reference being large 3: Speed reference being large 4: Speed reference change rate being large 5: Speed reference high-speed/low-speed thresholds 6: Position deviation being large 7: Position reference available 8: Positioning completion 9: Motor speed being large 10: Position reference available + Motor speed	-	Set the gain switchover condition.	During running	Immediate	0
H08-10	Gain switchover delay	0–10	-	Set the gain switchover delay.	During running	Immediate	5.0
H08-11	Gain switchover level	1–1000	Based on switchover condition	Set the gain switchover level.	During running	Immediate	50
H08-12	Gain switchover hysteresis	0–20000	Based on switchover condition	Set the gain switchover hysteresis.	During running	Immediate	30
H08-13	Position gain switchover time	0.0–100.0	ms	Set the gain switchover time of the position loop.	During running	Immediate	3.0

6.4.3 Filter Comparison

Name	Function	Applicable Scenario	Effect of Filter Excessive	Index
Pulse input pin filter	It prevents the problem that the number of pulses received by the servo drive is inaccurate due to interference.	The system wiring is incorrect. Strong interference exists in the environment.	The number of pulses received by the servo drive is smaller than that sent by the host controller.	Section 5.2.1
Position reference filter	It filters the position references (encoder unit) divided or multiplied by the electronic gear ratio, smoothing motor running and reducing impact to the machine.	Acceleration/Deceleration is absent on the position references from the host controller. The pulse frequency is too low. The electronic gear ratio is larger than 10.	The response delay becomes large.	Section 5.2.3
Analog input filter	It prevents motor command fluctuation due to instable analog input voltage, and reduces motor malfunction due to interference signals.	The system wiring is incorrect. Strong interference exists in the environment.	The response delay becomes large.	Sections 5.3.1 and 5.4.1

6.4.4 Feedforward Gain

1) Speed feedforward

Figure 6-9 Block diagram of speed feedforward control

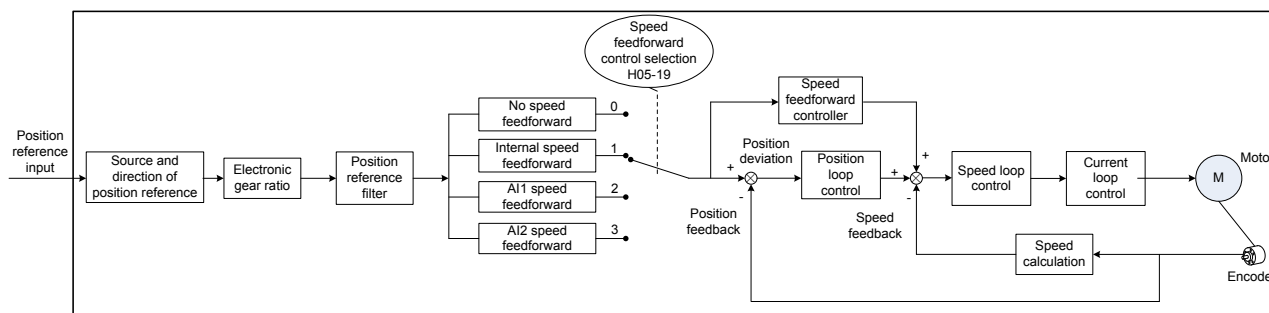

When position control or full closed-loop is used, the speed feedforward function can be used to improve speed reference response and reduce the position deviation at fixed speed.

The speed feedforward operations are as follows:

- a. Set the source of the speed feedforward signal.

Set H05-19 (Speed feedforward control selection) to a non-zero value; then, this function is enabled and a signal source is selected.

Function Code	Parameter Name	Value	Remarks
H05-19	Speed feedforward control selection	0: No speed feedforward	-
		1: Internal	Use the speed corresponding to the position reference (encoder unit) as the source of the speed feedforward signal.
		2: AI1	Use the speed corresponding to AI1 input as the source of the speed feedforward signal. For AI1 setting, see H03-80, H03-50, H03-51, H03-53, and H03-54.
		3: AI2	Use the speed corresponding to AI2 input as the source of the speed feedforward signal. For AI2 setting, see H03-80, H03-55, H03-56, H03-58, and H03-59.

b. Set the speed feedforward parameters.

Function Code	Parameter Name	Adjustment Description
H08-18	Time constant of speed feedforward filter	<p>Parameter function: Increasing H08-19 improves response but may cause speed overshoot during acceleration/deceleration. Decreasing H08-18 suppresses speed overshoot during acceleration/deceleration. Increasing H08-18 suppresses the noise in the case of long position reference update period and drive control period and uneven position reference pulse frequency, and suppresses jitter of the positioning completion signal.</p>
H08-19	Speed feedforward gain	<p>Adjustment method: Set H08-18 to a fixed value, and then increase H08-19 gradually from 0 to a certain value at which speed feedforward reaches the required effect. Adjust H08-18 and H08-19 repeatedly to find the balanced setting.</p>

6

2) Torque feedforward

Figure 6-10 Block diagram of speed feedforward control

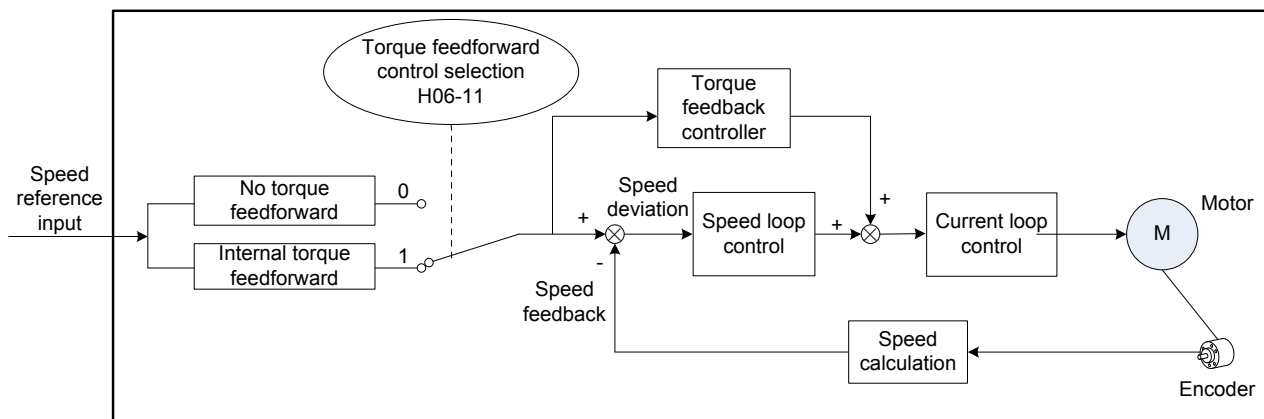

Torque feedforward used in the position control mode improves torque reference response and decreases the position deviation during acceleration/deceleration.

Torque feedforward used in the speed control mode improves torque reference response and decreases the position deviation at fixed speed.

The torque feedforward operations are as follows:

Step 1. Set the signal source of the torque feedforward signal.

Set H06-11 (Torque feedforward control selection) to 1, and this function is enabled and a signal source is selected.

Function Code	Parameter Name	Value	Description
H06-11	Torque feedforward selection	0: No torque feedforward	-
		1: Internal torque feedforward	Use the speed reference as the source of the torque feedforward signal. In the position control mode, the speed reference is the output from the position controller.

Step 2. Set the torque feedforward parameters.

Function Code	Parameter Name	Adjustment Description
H08-20	Time constant of torque feedforward filter	Parameter function: Increasing H08-21 improves response but may cause speed overshoot during acceleration/deceleration. Decreasing H08-20 suppresses overshoot during acceleration/deceleration. Increasing H08-20 suppresses the noise. Adjustment method: Set H08-20 to a fixed value, and then increase H08-21 gradually from 0 to a certain value at which torque feedforward reaches the required effect. Adjust H08-20 and H08-21 repeatedly to find the balanced setting.
H08-21	Torque feedforward gain	It improves response to torque references and decreases the position/speed deviation.

6.4.5 Pseudo-Differential Feedforward Control

In non-torque control mode, pseudo differential feedforward (PDFF) control can be used to adjust speed loop control.

Figure 6-11 PDFF example

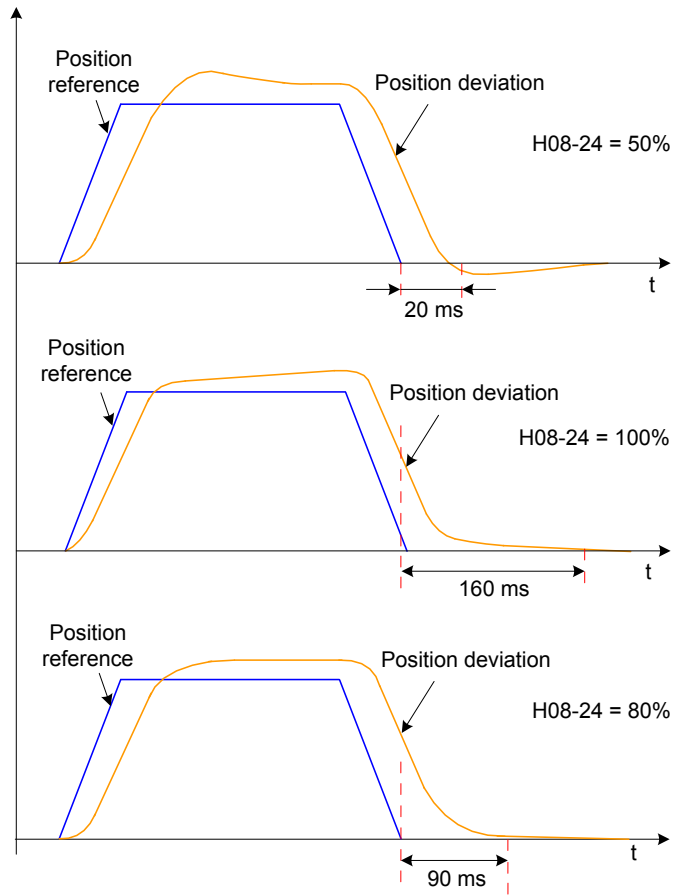

PDFF adjusts speed loop control, improving the anti-interference capability of the speed loop and improves speed reference compliance.

6

Function Code	Parameter Name	Adjustment Description
H08-24	PDFF control coefficient	<p>Parameter function: It adjusts the speed loop in non-torque control mode.</p> <p>Adjustment method: A very small setting of H08-24 makes the speed loop response slow. When speed feedback overshoot occurs, decrease H08-24 gradually from 100.0 to a certain value at which the PDFF effect is achieved.</p> <p>H08-24 = 100.0, speed loop control does not change, that is, the default proportional/integral control is used.</p>

6.4.6 Torque Disturbance Observer

This function is used in the non-torque control mode.

Figure 6-12 Block diagram of the disturbance observer

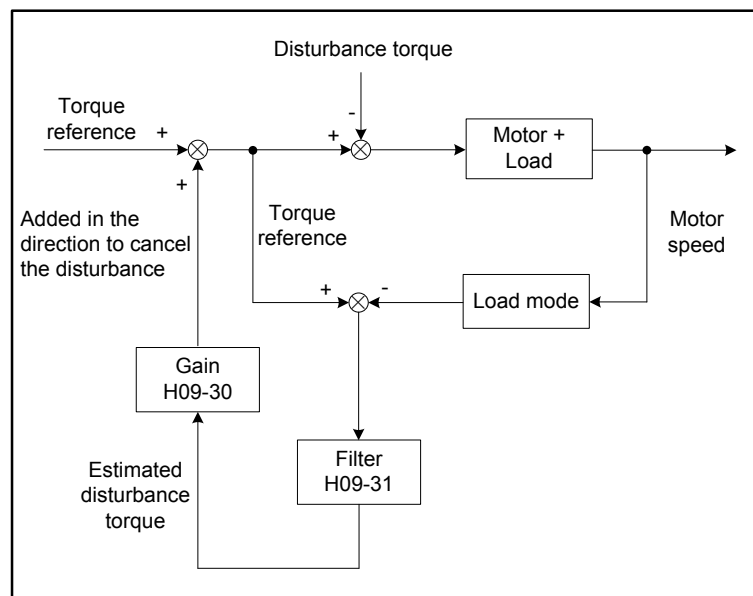

The disturbance observer detects and estimates the external disturbance torque on the system, and compensates the torque reference, which reduces the effect of external disturbance on the servo system and reduces vibration.

Function Code	Parameter Name	Adjustment Description
H09-30	Torque disturbance compensation gain	Parameter function: Increasing H09-30 (that is, increase the proportion of the compensation torque superpositioned to the torque reference) improves disturbance suppression but increases the noise.
H09-31	Time constant of torque disturbance observer filter	Increasing H09-31 reduces the noise. If H09-31 is decreased, the external disturbance torque with small delay can be detected and estimated, improving disturbance suppression but increasing the noise. Adjustment method: Set H09-31 to a larger value. Then, increase H09-30 gradually from 0 to a certain value at which the disturbance observer reaches the effect. Then, gradually decrease H09-31 on the condition that the disturbance observer keeps valid. Adjust H09-30 and H09-31 repeatedly to find the balanced setting.

Relevant parameters:

Function Code	Parameter Name	Setting Range	Unit	Description	Property	Effective Time	Default
H08-18	Time constant of speed feedforward filter	0.00–64.00	ms	Set the filter time constant of the speed feedforward gain.	During running	Immediate	0.00
H08-19	Speed feedforward gain	0.0–100.0	%	Set the speed feedforward gain.	During running	Immediate	0.0

Function Code	Parameter Name	Setting Range	Unit	Description	Property	Effective Time	Default
H08-20	Time constant of torque feedforward filter	0.00–64.00	ms	Set the filter time constant of the torque feedforward gain.	During running	Immediate	0.50
H08-21	Torque feedforward gain	0.0–200.0	ms	Set the torque feedforward gain.	During running	Immediate	0.0
H08-24	PDF control coefficient	0.0–100.0	%	Set the pseudo differential feedforward (PDF) control coefficient.	During running	Immediate	100.0
H09-30	Torque disturbance compensation gain	0–100.0	%	Set the disturbance torque compensation gain.	During running	Immediate	0.0
H09-31	Time constant of torque disturbance observer filter	0.00–25.00	ms	Set the time constant of the torque disturbance observer filter.	During running	Immediate	0.50

6.5 Parameter Adjustment in Different Control Modes

Perform parameter adjustment in the sequence of inertia auto-tuning, automatic gain tuning, and manual gain adjustment.

6.5.1 Parameter Adjustment in Position Control Mode

1) Obtain H08-15 (Load inertia ratio) through inertia auto-tuning.

2) Perform gain adjustment.

a. 1st gain

Function Code	Parameter Name	Description	Default
H07-05	Time constant of torque reference filter	Set the torque reference filter time constant.	0.79 ms
H08-00	Speed loop gain	Set the proportional gain of the speed loop.	25.0 Hz
H08-01	Time constant of speed loop integration	Set the integral time constant of the speed loop.	31.83 ms
H08-02	Position loop gain	Set the proportional gain of the position loop.	40.0 Hz

b. 2nd gain

Function Code	Parameter Name	Description	Default
H07-06	2nd time constant of torque reference filter	Set the torque reference filter time constant.	0.79 ms
H08-03	2nd gain of speed loop	Set the proportional gain of the speed loop.	40.0 Hz
H08-04	2nd time constant of speed loop integration	Set the integral time constant of the speed loop.	20.00 ms

Function Code	Parameter Name	Description	Default
H08-05	2nd gain of position loop	Set the proportional gain of the position loop.	64.0 ms
H08-08	2nd gain mode setting	Set the mode of the 2nd gain.	1
H08-09	Gain switchover condition	Set the gain switchover condition.	0
H08-10	Gain switchover delay	Set the gain switchover delay.	5.0 ms
H08-11	Gain switchover level	Set the gain switchover level.	50
H08-12	Gain switchover hysteresis	Set the gain switchover hysteresis.	30
H08-13	Position gain switchover time	Set the gain switchover time of the position loop.	3.0 ms

c. Common gain

Function Code	Parameter Name	Description	Default
H08-18	Time constant of speed feedforward filter	Set the filter time constant of the speed feedforward signal.	0.50 ms
H08-19	Speed feedforward gain	Set the speed feedforward gain.	0.0%
H08-20	Time constant of torque feedforward filter	Set the filter time constant of the torque feedforward signal.	0.50 ms
H08-21	Torque feedforward gain	Set the torque feedforward gain.	0.0%
H08-22	Speed feedback filter	Set the speed feedback function.	0
H08-23	Cutoff frequency of speed feedback low-pass filter	Set the cutoff frequency of the first-order low-pass filter for speed feedback.	4000 Hz
H08-24	PDFF control coefficient	Set the coefficient of the PDFF controller.	100.0%
H09-30	Disturbance torque compensation gain	Set the disturbance torque compensation gain.	0.0%
H09-31	Time constant of torque disturbance observer filter	Set the time constant of the torque disturbance observer filter.	0.5 ms
H09-04	Suppression mode of low-frequency resonance	Set the mode of suppressing low-frequency resonance.	0
H09-38	Frequency of low-frequency resonance	Set the frequency of the low-frequency resonance suppression filter.	100.0 Hz
H09-39	Filter setting of low-frequency resonance	Set the width of the low-frequency resonance suppression filter.	2
H0A-16	Position deviation threshold in low-frequency resonance	Set the position deviation threshold (in pulses) which can be judged as low-frequency resonance.	0.0005 Rev

3) Perform automatic gain tuning to obtain the initial values of the 1st gain (or 2nd gain) and common gain.

4) Manually adjust the following gain parameters.

Function Code	Parameter Name	Description
H07-05	Time constant of torque reference filter	Set the torque reference filter time constant.
H08-00	Speed loop gain	Set the proportional gain of the speed loop.

Function Code	Parameter Name	Description
H08-01	Time constant of speed loop integration	Set the integral time constant of the speed loop.
H08-02	Position loop gain	Set the proportional gain of the position loop.
H08-19	Speed feedforward gain	Set the speed feedforward gain.

6.5.2 Parameter Adjustment in Speed Control Mode

Parameter adjustment in the speed control mode is the same as that in the position control mode in section 7.5.1, except for the position loop gain (H08-02 and H08-05).

6.5.3 Parameter Adjustment in Torque Control Mode

Parameter adjustment in torque control mode are classified into two types based on the condition:

When the actual speed reaches the speed limit (for the speed limit in torque control mode, refer to Chapter 5), the adjustment method is the same as that described in section 6.5.2.

If the actual speed does not reach the speed limit, the adjustment method is the same as that described in section 6.5.2, except for the position/speed loop gain and time constant of the speed loop integration.

6.6 Vibration Suppression

6.6.1 Suppression of Mechanical Resonance

Resonance may occur at vicinity of the mechanical resonance frequency when the servo gain is increased, making the gain cannot be increased further.

Mechanical resonance can be suppressed in the following two methods:

1) Torque reference filter (H07-05, H07-06)

Set the filter time constant to damp the torque reference at above the cutoff frequency, suppressing mechanical resonance.

$$\text{Filter cutoff frequency } f_c \text{ (Hz)} = 1/[2\pi \times \text{H07-05 (ms)} \times 0.001]$$

2) Notch:

The notch reduces the gain at certain frequencies to suppress mechanical resonance. After resonance is suppressed with correct setting of the notch, attempt to increase the gain gradually. The following figure shows the resonance suppression principle of the notch.

Figure 6-13 Resonance suppression principle of the notch

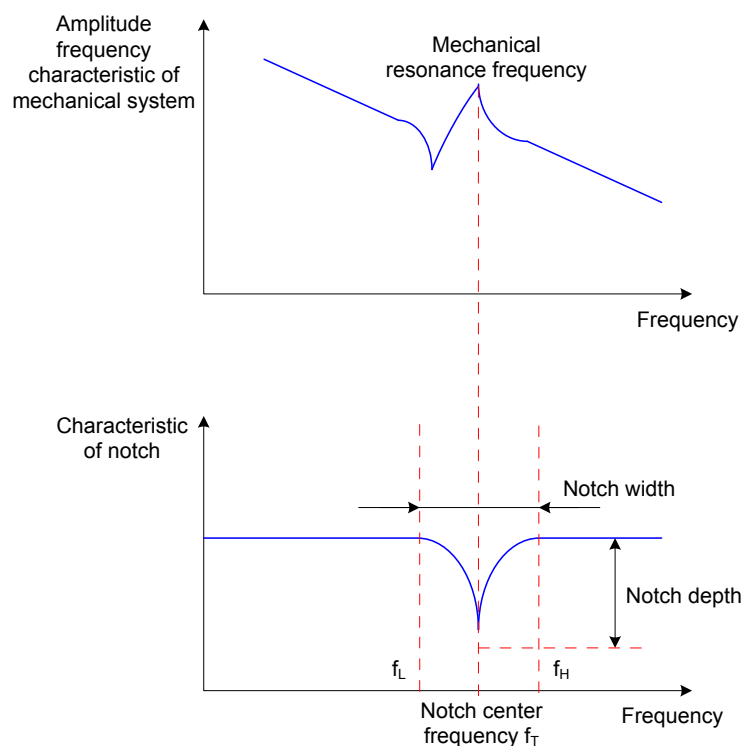

A total of four notches can be used, and each is defined by three parameters, frequency, width level, and depth level. The 1st and 2nd notches are manual ones, and their parameters are set manually by users. The 3rd and 4th notches can be set manually or set as adaptive notches (H09-02 = 1 or 2); when they are used as adaptive notches, their parameters are automatically set by the servo drive.

Table 6-9 Notch descriptions

Item	Manual Notch		Manual/Adaptive Notch	
	1st Notch	2nd Notch	3rd Notch	4th Notch
Frequency	H09-12	H09-15	H09-18	H09-21
Width level	H09-13	H09-16	H09-19	H09-22
Depth level	H09-14	H09-17	H09-20	H09-23

Note

When the frequency is the default value 4,000 Hz, the notch is actually invalid.

**CAUTION**

The adaptive notch is preferred during the use. If the adaptive notch is invalid or cannot produce satisfactory performance, use the manual notch.

Figure 6-14 Use procedure of the notch

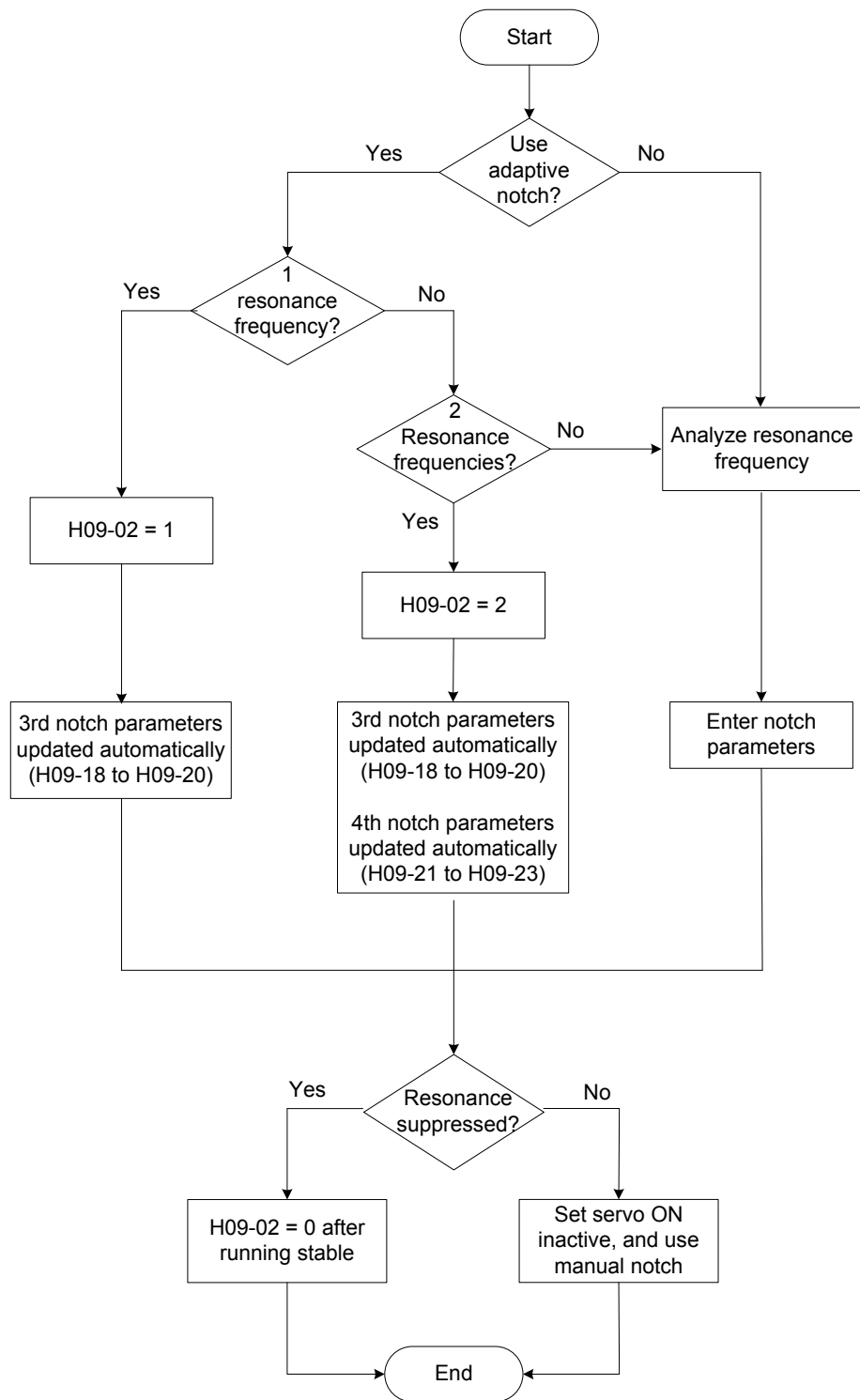

6

a. The use procedure of the adaptive notch is as follows:

Step 1. Set H09-02 (Mode selection of adaptive notch) to 1 or 2 based on the number of resonance frequencies.

When resonance occurs, first set H09-02 to 1 to enable an adaptive notch. If new resonance occurs after the gain is adjusted, set H09-02 to 2 to enable both adaptive notches.

Step 2. During servo running, the parameters of the 3rd or 4th notch are updated automatically, and the values are automatically stored to the corresponding function codes in group H09 every 30 minutes.

Step 3. If resonance is suppressed, the adaptive notch functions well. After the servo remains stable for a certain period, set H09-02 to 0, and the parameters of the adaptive notch are fixed at the last updated values.

Otherwise, malfunction during servo running makes the notch parameters be changed to incorrect values, increasing vibration.

Step 4. If vibration fails to be suppressed, turn off the servo ON signal in time.

If there are more than two resonance frequencies, the problem cannot be solved by only using the adaptive notches. Additionally use the manual notch, or use all the four notches as manual ones (H09-02 = 0).



During use of the adaptive notch, the latest parameters will not be stored into the corresponding function codes if the servo becomes OFF within 30 minutes.

When the resonance frequency is below 300 Hz, the suppression effect of the adaptive notch may degrade.

b. The use procedure of the manual notch is as follows:

Step 1. Analyze the resonance frequency.

When using the manual notch, set the frequency to the actual resonance frequency, which is obtained by using the following methods:

Use the "Mechanical analysis" function in Inovance servo commissioning software.

Calculate the resonance frequency based on the motor phase current displayed on the oscilloscope interface of Inovance servo commissioning software.

Set H09-02 to 3. After starting running, the servo drive automatically detects the resonance frequency and stores it in H09-24.

Step 2. Enter the obtained resonance frequency in the parameter of the selected notch, and set the width level and depth level of the notch.

Step 3. If resonance is suppressed, the notch functions well. Then, increase the gain. If new resonance occurs, repeat steps 1 and 2.

Step 4. If vibration fails to be suppressed, turn servo OFF in time.

c. Notch width level

The notch width level indicates the ratio of the notch width to the notch center frequency.

$$\text{Notch width level} = \frac{f_H - f_L}{f_T}$$

Where:

f_T : Notch center frequency, that is, mechanical resonance frequency

$f_H - f_L$: Notch width, indicating the ratio of -3dB attenuation frequency band with respect to the notch center frequency

Figure 6-15 shows the relationship between notch width and depth. Use the default value 2.

d. Notch depth level

The notch depth level indicates the ratio of input to output at center frequency.

The input is completely shut with depth level 0 and fully received with depth level 100 at the center frequency. A smaller notch depth level indicates larger notch depth, which produces stronger

resonance suppression and makes the system instable. Pay attention to this during use.



CAUTION If the amplitude frequency characteristic curve obtained through the mechanical analysis function does not have obvious peak, it indicates that vibration occurs actually. Such vibration may not be mechanical resonance, and cannot be suppressed by the notch. It occurs because the gain reaches the limit, and can be suppressed only by reducing the gain or the filter time of torque reference.

The following figure shows the relationship between notch width and depth.

Figure 6-15 Frequency characteristic curve of notch

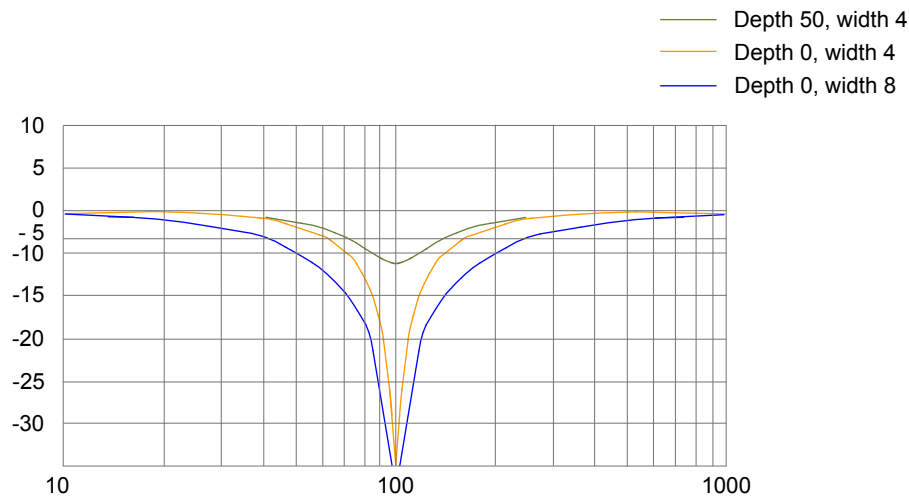

Relevant parameters:

Function Code	Parameter Name	Setting Range	Unit	Description	Property	Effective Time	Default
H09-02	Mode selection of adaptive notch	0: Parameters not updated 1: Only one notch (3rd notch) valid, parameters updated in real time 2: Both notches (3rd and 4th notches) valid, parameters updated in real time 3: Only detect resonance frequency (displayed in H09-24) 4: Clear 3rd and 4th notches, restore parameters to default setting	-	Set the working mode of the adaptive notches.	During running	Immediate	0

Function Code	Parameter Name	Setting Range	Unit	Description	Property	Effective Time	Default
H09-12	1st notch frequency	50–4000	Hz	Set the frequency of the 1st notch.	During running	Immediate	4000
H09-13	1st notch width level	0–10	-	Set the width level of the 1st notch.	During running	Immediate	2
H09-14	1st notch depth level	0–99	-	Set the attenuation level of the 1st notch.	During running	Immediate	0
H09-15	2nd notch frequency	50–4000	Hz	Set the frequency of the 2nd notch.	During running	Immediate	4000
H09-16	2nd notch width level	0–10	-	Set the width level of the 2nd notch.	During running	Immediate	2
H09-17	2nd notch depth level	0–99	-	Set the attenuation level of the 2nd notch.	During running	Immediate	0
H09-18	3rd notch frequency	50–4000	Hz	Set the frequency of the 3rd notch.	During running	Immediate	4000
H09-19	3rd notch width level	0–10	-	Set the width level of the 3rd notch.	During running	Immediate	2
H09-20	3rd notch depth level	0–99	-	Set the attenuation level of the 3rd notch.	During running	Immediate	0
H09-21	4th notch frequency	50–4000	Hz	Set the frequency of the 4th notch.	During running	Immediate	4000
H09-22	4th notch width level	0–10	-	Set the width level of the 4th notch.	During running	Immediate	2
H09-23	4th notch depth level	0–99	-	Set the attenuation level of the 4th notch.	During running	Immediate	0
H09-24	Obtained resonance frequency	-	Hz	Display the auto-tuned resonance frequency when H09-02 = 3.	-	-	0

6.6.2 Suppression of Low-frequency Resonance

Figure 6-16 Mechanical diagram of low-frequency resonance

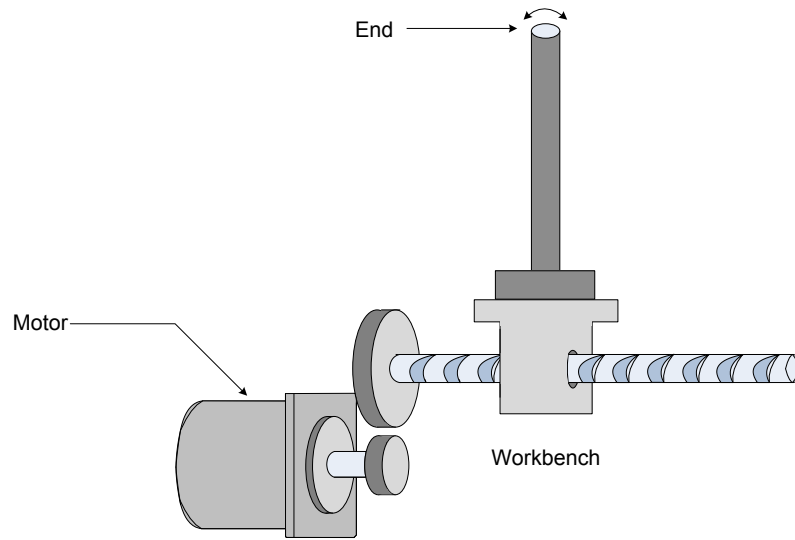

If the mechanical load end is long and heavy, vibration may easily occur in this part at emergency stop, affecting the positioning. Such vibration has a frequency about 100 Hz, lower than the mechanical resonance frequency, and is called low-frequency resonance. Use the low-frequency resonance suppression function to reduce such vibration.

Figure 6-17 Use procedure of low-frequency resonance suppression filter

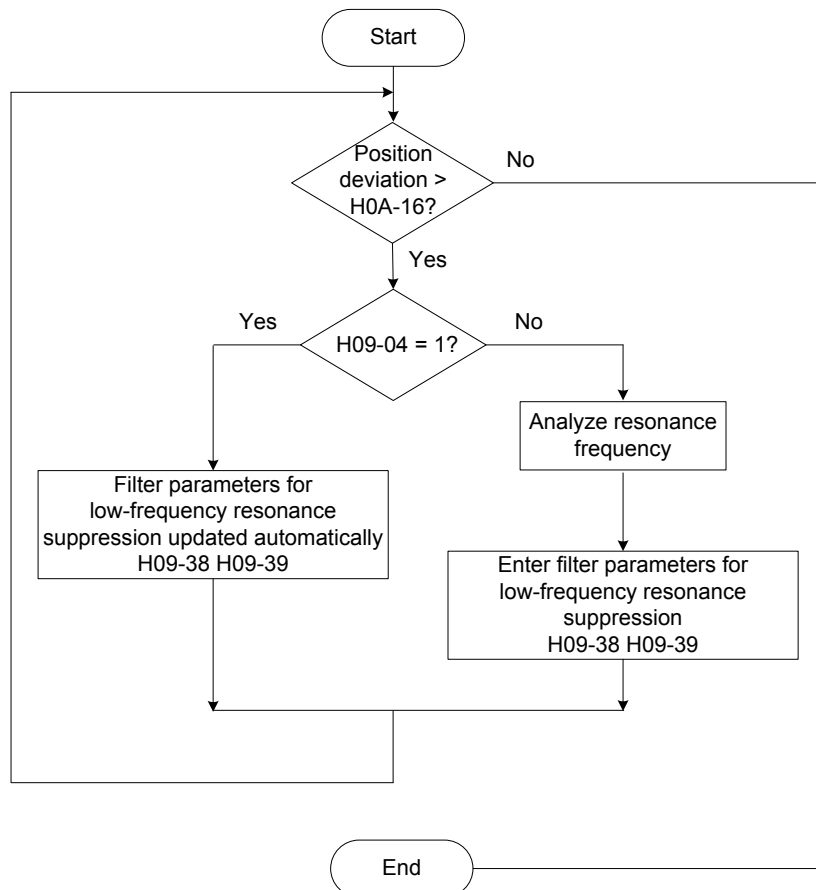

Step 1. Set H0A-16 (Position deviation threshold in low-frequency resonance).

The system considers that low-frequency resonance occurs when the position deviation exceeds H0A-16. Resonance may be detected more easily if this parameter is set to a small value.

Step 2. Set H09-04 (Suppression mode of low-frequency resonance).

The servo drive provides two methods, and the automatic method is preferred.

a. H09-04 = 1 (Automatically set parameters of low-frequency resonance suppression filter)

The servo drive automatically detects the frequency and amplitude of the low-frequency resonance, and automatically sets H09-38 (Frequency of low-frequency resonance) and H09-39 (Filter setting of low-frequency resonance).

b. H09-04 = 0 (Manually set parameters of low-frequency resonance suppression filter)

Collect the position deviation waveform in motor positioning mode by using the oscilloscope function of the Inovance servo commissioning software and calculate the position deviation fluctuation frequency, that is, low-frequency resonance frequency.

Then, manually input the value into H09-38, and use the default value of H09-39.

Step 3. Observe whether the position deviation still exceeds H01-16 after the low-frequency resonance suppression filter is used.

If yes, repeat steps 2 to 3; if not, it indicates that the low-frequency resonance suppression effect is achieved.

Figure 6-18 Low-frequency resonance suppression effect

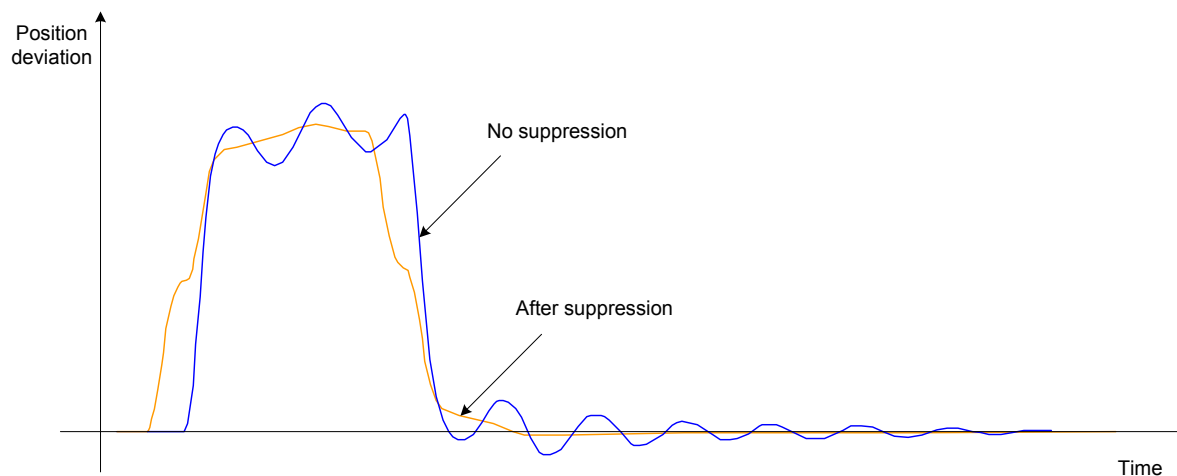

Relevant parameters:

Function Code	Parameter Name	Setting Range	Unit	Description	Property	Effective Time	Default
H09-04	Suppression mode of low-frequency resonance	0: Manually set parameters of low-frequency resonance suppression filter 1: Automatically set parameters of low-frequency resonance suppression filter	-	Set the mode of suppressing low-frequency resonance.	During running	Immediate	0
H09-38	Frequency of low-frequency resonance	1.0–100.0	Hz	Set the frequency of the low-frequency resonance filter.	During running	Immediate	100.0
H09-39	Filter setting of low-frequency resonance	0–10	-	Set the width level of the low-frequency resonance suppression filter.	During running	Immediate	2
H0A-16	Position deviation threshold in low-frequency resonance	1–1000	P	Set the position deviation threshold (in pulses) which can be judged as low-frequency resonance.	During running	Immediate	5



7 Description of Parameters

Group H00: Servo Motor Parameters.....	303
Group H01: Servo Drive Parameters.....	306
Group H02: Basic Control Parameters	307
Group H03: Input Terminal Parameters.....	314
Group H04: Output Terminal Parameters	324
Group H05: Position Control Parameters.....	329
Group H06: Speed Control Parameters	345
Group H07: Torque Control Parameters.....	352
Group H08: Gain Parameters.....	358
Group H09: Automatic Gain Tuning Parameters	365
Group H0A: Fault and Protection Parameters.....	371
Group H0B: Monitoring Parameters	376
Group H0C: Communication Parameters.....	383
Group H0D: Auxiliary Function Parameters.....	388
Group H0F: Full Closed-Loop Parameters	392
Group H11: Multi-Position Function Parameters	395
Group H12: Multi-Speed Function Parameters.....	399
Group H17: VDI/VDO Parameters.....	402
Group H30: Servo Variables Read by Communication.....	406
Group H31: Servo Variables Set via Communication	408

Chapter 7 Description of Parameters

Parameter Group	Description
H00	Servo motor parameters
H01	Servo drive parameters
H02	Basic control parameters
H03	Input terminal parameters
H04	Output terminal parameters
H05	Position control parameters
H06	Speed control parameters
H07	Torque control parameters
H08	Gain parameters
H09	Automatic gain tuning parameters
H0A	Fault and protection parameters
H0B	Monitoring parameters
H0C	Communication parameters
H0D	Auxiliary function parameters
H0F	Full closed-loop function parameters
H11	Multi-position function parameters
H12	Multi-speed function parameters
H17	VDI/VDO parameters
H30	Servo variables read via communication
H31	Servo variables set via communication

Group H00: Servo Motor Parameters

7

H00-00	Parameter Name	Motor SN			Property	At stop	Control Mode	PST
	Setting Range	14000, 14101	Unit	1	Effective Time	Power-on again	Default	14000
It sets SN of servo motor.								
		Value	Motor SN					
		14000	Inovance 20-bit incremental encoder motor					
		14101	Inovance 23-bit absolute encoder motor					
For the IS620P servo drive, 20-bit (1048576 P/r) serial encoder motor is matched. In this case, H00-00 is set to 14000. For SN of 20-bit (1048576 P/r) encoder, view H00-05.								

H00-02	Parameter Name	Customized firmware version			Property	At display	Control Mode	-
	Setting Range	-	Unit	-	Effective Time	-	Default	-
<p>It displays customized firmware version in hexadecimal.</p> <p>For the IS620P servo drive, the display format is 6XX.YY.</p> <p>XX: Customized firmware version</p> <p>YY: Customized firmware version update record</p>								
H00-04	Parameter Name	Encoder version			Property	At display	Control Mode	-
	Setting Range	-	Unit	-	Effective Time	-	Default	-
<p>It displays the encoder version.</p> <p>The display format is 20XX.Y.</p> <p>20: The encoder resolution is 20-bit (1048576 P/r).</p>								
H00-05	Parameter Name	Serial encoder motor SN			Property	At display	Control Mode	-
	Setting Range	-	Unit	-	Effective Time	-	Default	-
<p>It displays the serial encoder motor SN. It is determined by motor model and cannot be modified.</p>								
H00-09	Parameter Name	Rated voltage			Property	At stop	Control Mode	-
	Setting Range	0 to 220 1 to 380	Unit	V	Effective Time	Power-on again	Default	-
H00-10	Parameter Name	Rated power			Property	At stop	Control Mode	-
	Setting Range	0.01 to 655.35	Unit	kW	Effective Time	Power-on again	Default	-
H00-11	Parameter Name	Rated current			Property	At stop	Control Mode	-
	Setting Range	0.01 to 655.35	Unit	A	Effective Time	Power-on again	Default	-
H00-12	Parameter Name	Rated torque			Property	At stop	Control Mode	-
	Setting Range	0.01 to 655.35	Unit	Nm	Effective Time	Power-on again	Default	-
H00-13	Parameter Name	Max. torque			Property	At stop	Control Mode	-
	Setting Range	0.10 to 655.35	Unit	Nm	Effective Time	Power-on again	Default	-

H00-14	Parameter Name	Rated motor speed			Property	At stop	Control Mode	-
	Setting Range	100 to 6000	Unit	RPM	Effective Time	Power-on again	Default	-
H00-15	Parameter Name	Max. motor speed			Property	At stop	Control Mode	-
	Setting Range	100to 6000	Unit	RPM	Effective Time	Power-on again	Default	-
H00-16	Parameter Name	Rotor inertia Jm			Property	At stop	Control Mode	-
	Setting Range	0.01 to 655.35	Unit	kgcm ²	Effective Time	Power-on again	Default	-
H00-17	Parameter Name	Number of pole pairs of PMSM			Property	At stop	Control Mode	-
	Setting Range	2 to 360	Unit	Pole-pair	Effective Time	Power-on again	Default	-
H00-18	Parameter Name	Stator resistance			Property	At stop	Control Mode	-
	Setting Range	0.001 to 65.535	Unit	Ω	Effective Time	Power-on again	Default	-
H00-19	Parameter Name	Stator inductance Lq			Property	At stop	Control Mode	-
	Setting Range	0.01 to 655.35	Unit	mH	Effective Time	Power-on again	Default	-
H00-20	Parameter Name	Stator inductance Ld			Property	At stop	Control Mode	-
	Setting Range	0.01 to 655.35	Unit	mH	Effective Time	Power-on again	Default	-
H00-21	Parameter Name	Linear back EMF coefficient			Property	At stop	Control Mode	-
	Setting Range	0.01 to 655.35	Unit	mV/RPM	Effective Time	Power-on again	Default	-
H00-22	Parameter Name	Torque coefficient Kt			Property	At stop	Control Mode	-
	Setting Range	0.01 to 655.35	Unit	Nm/Arms	Effective Time	Power-on again	Default	-
H00-23	Parameter Name	Electrical constant Te			Property	At stop	Control Mode	-
	Setting Range	0.01 to 655.35	Unit	ms	Effective Time	Power-on again	Default	-

H00-24	Parameter Name	Mechanical constant Tm			Property	At stop	Control Mode	-
	Setting Range	0.01 to 655.35	Unit	ms	Effective Time	Power-on again	Default	-
H00-28	Parameter Name	Position offset of absolute encoder			Property	At stop	Control Mode	-
	Setting Range	0 to 1073741824	Unit	P/r	Effective Time	Power-on again	Default	-
H00-30	Parameter Name	Encoder selection (Hex)			Property	At stop	Control Mode	-
	Setting Range	0x000: Common incremental encoder (UVW-ABZ) 0x013: Inovance 20-bit serial encoder		Unit	1	Effective Time	Power-on again	Default 0x013
H00-31	Parameter Name	PPR of encoder			Property	At stop	Control Mode	-
	Setting Range	1 to 1073741824	Unit	P/r	Effective Time	Power-on again	Default	1048576
H00-33	Parameter Name	Electrical angle of signal Z			Property	At stop	Control Mode	-
	Setting Range	0.0 to 360	Unit	°	Effective Time	Power-on again	Default	180
H00-34	Parameter Name	Electrical angle of phase U rise edge			Property	At stop	Control Mode	-
	Setting Range	0.0 to 360	Unit	°	Effective Time	Power-on again	Default	180

Group H01: Servo Drive Parameters

H01-00	Parameter Name	MCU firmware version			Property	At display	Control Mode	-
	Setting Range	0 to 65535	Unit	-	Effective Time	-	Default	-
It displays the MCU firmware version. The display format is XXXX.Y.								
H01-01	Parameter Name	FPGA firmware version			Property	Property	Control Mode	-
	Setting Range	0 to 65535	Unit	-	Effective Time	-	Default	-
It displays the FPGA firmware version. The display format is XXXX.Y.								

H01-02	Parameter Name	Servo drive SN			Property	At stop	Control Mode	-
	Setting Range	0 to 65535	Unit	-	Effective Time	Power-on again	Default	-

It sets SN of the servo drive.

The IS620P servo drive and IS6200P servo drive have the same servo drive SN.

Value	Servo Drive SN	Description
2	S1R6	The rated drive power is 0.2 kW and single-phase 220 V is input.
3	S2R8	The rated drive power is 0.4 kW and single-phase 220 V is input.
5	S5R5	The rated drive power is 0.75 kW and single-phase/three-phase 220 V (*1) is input.
6	S7R6	The rated drive power is 1.0 kW and three-phase 220 V is input.
7	S012	The rated drive power is 1.5 kW and three-phase 220 V is input.
10001	T3R5	The rated drive power is 1.0 kW and three-phase 380 V is input.
10002	T5R4	The rated drive power is 1.5 kW and three-phase 380V is input.
10003	T8R4	The rated drive power is 2.0 kW and three-phase 380V is input.
10004	T012	The rated drive power is 3.0 kW and three-phase 380V is input.
10005	T017	The rated drive power is 5.0 kW and three-phase 380V is input.
10006	T021	The rated drive power is 6.0 kW and three-phase 380V is input.
10007	T026	The rated drive power is 7.5 kW and three-phase 380V is input.

If servo drive SN is set incorrectly, Er.120 (product model matching fault) will be detected.

If main circuit power supply of the servo drive does not comply with the preceding specification, Er.420 (power cable phase loss) or Er.990 (power input phase loss warning) will be detected.

Note:

*1: The main circuit power supply specification of the servo drive is three-phase 220 V. But when H0A-00 = 2, single-phase 220 V can be used.

Group H02: Basic Control Parameters

H02-00	Parameter Name	Control mode selection			Property	At stop	Control Mode	-
	Setting Range	0 to 6	Unit	-	Effective Time	Immediate	Default	1
It sets control mode of the servo drive.								
Value	Meaning	Description						
0	Speed mode	For parameter settings in speed mode, refer to section 5.3.						
1	Position mode	For parameter settings in position mode, refer to section 5.2.						
2	Torque mode	For parameter settings in torque mode, refer to section 5.4.						
3	Torque mode/ Speed mode	Set a DI terminal for FunIN.10: M1_SEL (Mode switchover 1) and determine terminal logic.						
		M1_SEL Terminal Logic		Control Mode				
		Invalid		Torque mode				
		Valid		Speed mode				
4	Speed mode/ Position mode	Set a DI terminal for FunIN.10: M1_SEL (Mode switchover 1) and determine terminal logic.						
		M1_SEL Terminal Logic		Control Mode				
		Invalid		Speed mode				
		Valid		Position mode				
5	Torque mode/ Position mode	Set a DI terminal for FunIN.10: M1_SEL (Mode switchover 1) and determine terminal logic.						
		M1_SEL Terminal Logic		Control Mode				
		Invalid		Torque mode				
		Valid		Position mode				
6	Torque mode/ Speed mode/ Position mode	Set two DI terminal for FunIN.10: M1_SEL (Mode switchover 1) and FunIN.11: M2_SEL (Mode switchover 2), respectively and determine terminal logic.						
		M2_SEL Terminal Logic		M1_SEL Terminal Logic		Control Mode		
		Invalid		Invalid		Torque mode		
		Valid		Invalid		Speed mode		
		-		valid		Position mode		

H02-01	Parameter Name	Absolute system selection			Property	At stop	Control Mode	PST
	Setting Range	0 to 2	Unit	1	Effective Time	Power-on again	Default	0

It selects the absolute position function of the servo drive.

0: Incremental position mode
 1: Absolute position linear mode
 2: Absolute position rotating mode

H02-02	Parameter Name	Rotating direction selection			Property	At stop	Control Mode	PST
	Setting Range	0, 1	Unit	-	Effective Time	Power-on again		Setting Range

It sets forward motor rotating direction seen from motor shaft side.

Value	Meaning	Description
0	CCW direction as forward direction	When forward reference is input, motor rotates in CCW direction seen from motor shaft side, that is, motor rotates counterclockwise.
1	CW direction as forward direction	When forward reference is input, motor rotates in CW direction seen from motor shaft side, that is, motor rotates clockwise.

Clockwise (CW)

Counterclockwise (CCW)

H02-03	Parameter Name	Output pulse phase			Property	At stop	Control Mode	PST
	Setting Range	0, 1	Unit	-	Effective Time	Power-on again	Default	0

It sets relationship between phase A and phase B on the condition that motor rotating direction remains unchanged when pulse output is enabled.

Value	Meaning	Description
0	Phase A advancing phase B	Phase A advances phase B by 90° in frequency-dividing output pulses of encoder.
1	Phase A lagging phase B	Phase A lags phase B by 90° in frequency-dividing output pulses of encoder.

H02-05	Parameter Name	Stop mode at S-ON off			Property	At stop	Control Mode	PST
	Setting Range	0 to 1	Unit	-	Effective Time	Immediate	Default	0

It selects deceleration mode of servo motor from rotation to stop and the servo motor status after stop when S-ON signal (S-ON) is set to OFF.

It sets proper stop mode according to matching status and running requirement.

For comparison of stop modes, refer to section 5.1.6.

H02-06	Parameter Name	Stop mode at NO.2 fault			Property	At stop	Control Mode	PST
	Setting Range	0 to 1	Unit	-	Effective Time	Immediate	Default	0

It selects deceleration mode of servo motor from rotation to stop and the servo motor status at occurrence of NO.2 resettable fault.

Value	Meaning
0	Coast to stop, keeping de-energized state
1	Emergency stop, keeping de-energized state

For details on NO.2 resettable fault, refer to Chapter 8.

For comparison of stop modes, refer to section 5.1.6.

Note:

If NO.2 resettable fault occurs after the brake is enabled, H02-06 is set to 1 (emergency stop, de-energized) compulsively.

H02-07	Parameter Name	Stop mode at limit switch signal			Property	At stop	Control Mode	PST
	Setting Range	0 to 2	Unit	-	Effective Time	Immediate	Default	1

It selects deceleration mode of servo motor from rotation to stop and the servo motor status when the limit switch signal is active during motor running.

Value	Meaning
0	Coast to stop, keeping de-energized state
1	Emergency stop, keeping position locking state
2	Emergency stop, keeping de-energized state

When servo motor drives vertical axis, you should set H02-07 = 1 to make motor shaft in position locking state after the limit switch signal is active to ensure safety.

For comparison of stop modes, refer to section 5.1.9.

H02-08	Parameter Name	Stop mode at NO.1 fault			Property	At stop	Control Mode	PST				
	Setting Range	0	Unit	-	Effective Time	Immediate	Default	0				
<p>It selects deceleration mode of servo motor from rotation to stop and the servo motor status at occurrence of NO.1 fault.</p> <table border="1"> <thead> <tr> <th>Value</th> <th>Meaning</th> </tr> </thead> <tbody> <tr> <td>0</td> <td>Coast to stop, keeping de-energized state</td> </tr> </tbody> </table> <p>For details on NO.1 fault, refer to Chapter 8. For comparison of stop modes, refer to section 5.1.9.</p>									Value	Meaning	0	Coast to stop, keeping de-energized state
Value	Meaning											
0	Coast to stop, keeping de-energized state											
H02-09	Parameter Name	Delay from brake output ON to command received			Property	During running	Control Mode	PS				
	Setting Range	0 to 500	Unit	ms	Effective Time	Immediate	Default	250				
<p>It sets delay time from the time when the brake output signal becomes ON to the moment when the servo drive starts to receive commands after power-on.</p> <p>Within the setting of H02-09, the servo drive does not receive position/speed/torque reference.</p> <p>Refer to section 5.1.6 to view brake sequence diagram at motor standstill.</p>												
H02-10	Parameter Name	Delay from brake output OFF to motor de-energized in static state			Property	During running	Control Mode	PS				
	Setting Range	1 to 1000	Unit	ms	Effective Time	Immediate	Default	150				
<p>It sets delay time from the moment when the brake output signal becomes OFF to the moment when the motor enters power-off state when motor is static.</p> <p>Refer to section 5.1.6 to view brake time sequence at motor static.</p>												
H02-11	Parameter Name	Motor speed threshold at brake output OFF in rotating state			Property	During running	Control Mode	PS				
	Setting Range	0 to 3000	Unit	RPM	Effective Time	Immediate	Default	30				
<p>It sets the motor speed threshold when the brake output signal becomes OFF in the motor rotating state.</p> <p>Refer to section 6.1.6 to view brake time sequence at motor rotating.</p>												
H02-12	Parameter Name	Delay from brake output OFF to motor de-energized in rotating state			Property	During running	Control Mode	PS				
	Setting Range	1 to 1000	Unit	ms	Effective Time	Immediate	Default	500				
<p>It sets delay time from the moment when the S-ON signal is turned off to the moment when the brake output signal becomes OFF in the motor rotating state.</p> <p>Refer to section 5.1.4 to view brake time sequence at motor rotating.</p>												

H02-15	Parameter Name	Warning display on keypad			Property	At stop	Control Mode	PST									
	Setting Range	0 to 1	Unit	-	Effective Time	Immediate	Default	0									
It sets whether keypad switches over to the fault display mode when NO.3 resettable warning occurs on the servo drive.																	
<table border="1"> <thead> <tr> <th>Value</th> <th>Meaning</th> <th>Description</th> </tr> </thead> <tbody> <tr> <td>0</td> <td>Output warning information immediately</td> <td>The keypad displays the warning code in real time once NO.3 resettable warning occurs.</td> </tr> <tr> <td>1</td> <td>Not output warning information</td> <td>The keypad displays only NO.1 fault and NO.2 fault and does not display NO.3 warning. To check whether NO.3 warning occurs for the recent 10 times, view H0B-33 and H0B-34.</td> </tr> </tbody> </table>									Value	Meaning	Description	0	Output warning information immediately	The keypad displays the warning code in real time once NO.3 resettable warning occurs.	1	Not output warning information	The keypad displays only NO.1 fault and NO.2 fault and does not display NO.3 warning. To check whether NO.3 warning occurs for the recent 10 times, view H0B-33 and H0B-34.
Value	Meaning	Description															
0	Output warning information immediately	The keypad displays the warning code in real time once NO.3 resettable warning occurs.															
1	Not output warning information	The keypad displays only NO.1 fault and NO.2 fault and does not display NO.3 warning. To check whether NO.3 warning occurs for the recent 10 times, view H0B-33 and H0B-34.															
For details on NO.3 warning, refer to Chapter 8.																	

H02-18	Parameter Name	Filter time of S-ON signal			Property	At stop	Control Mode	PST
	Setting Range	0 to 64	Unit	ms	Effective Time	Immediate	Default	0
It sets the filter time constant of the digital input function 1 (FunIN.1: S-ON).								
When FunIn.1: S-ON is allocated to a low-speed DI terminal, the signal width must be larger than (H02-18) + 3 ms. Otherwise, the S-ON signal is inactive.								
When FunIn.1: S-ON is allocated to a high-speed DI terminal, the signal width must be larger than (H02-18) + 0.25 ms. Otherwise, the S-ON signal is inactive.								
When FunIn.1: S-ON is allocated to a VDI terminal, the signal width must be larger than (H02-18) + 1 ms. Otherwise, the S-ON signal is inactive.								
The DI S-ON signal displayed on the oscilloscope does not require filter set in H02-18.								

H02-21	Parameter Name	Permissible minimum resistance of regenerative resistor			Property	At display	Control Mode	PST
	Setting Range	-	Unit	Ω	Effective Time	-	Default	-
The allowed minimum value of regenerative resistor is dependent on drive model.								

H02-22	Parameter Name	Power of built-in regenerative resistor			Property	At display	Control Mode	PST
	Setting Range	-	Unit	W	Effective Time	-	Default	-
The power of built-in regenerative resistor is dependent on drive model and cannot be modified.								

H02-23	Parameter Name	Resistance of built-in regenerative resistor			Property	At display	Control Mode	PST
	Setting Range	-	Unit	Ω	Effective Time	-	Default	-

The resistance of built-in regenerative resistor is dependent on drive model and cannot be modified.

When maximum braking energy absorbed by bus capacitors is smaller than the calculated value of maximum braking energy, use regenerative resistor.

When using built-in regenerative resistor, connect a jumper link across terminals "P" and "D".

When H01-02 (servo drive SN) = 1, 2, or 3, there is no built-in regenerative resistor.

H02-24	Parameter Name	Resistor heat dissipation coefficient			Property	At stop	Control Mode	PST
	Setting Range	10 to 100	Unit	%	Effective Time	Immediate	Default	30

It sets heat dissipation coefficient of regenerative resistor, which is valid for both built-in and external regenerative resistor.

Set this parameter properly according to dissipation condition of the actually used resistor.

Recommendation:

Generally, the setting of H02-24 does not exceed 30% for naturally ventilated.

The setting of H02-24 does not exceed 50% for forcible cooling.

H02-25	Parameter Name	Regenerative resistor type			Property	At stop	Control Mode	PST
	Setting Range	0 to 3	Unit	-	Effective Time	Immediate	Default	0

It sets the mode of absorbing and releasing braking energy.

Value	Mode of Absorbing and Releasing Braking Energy	Description
0	Built-in	It is used when calculated value of maximum braking energy > maximum braking energy absorbed by capacitors and calculated value of braking power \leq built-in regenerative resistor power.
1	External, naturally ventilated	It is used when calculated value of maximum braking energy > maximum braking energy absorbed by capacitors and calculated value of braking power > built-in regenerative resistor power.
2	External, forcible cooling	It is used when calculated value of maximum braking energy > maximum braking energy absorbed by capacitors and calculated value of braking power > built-in regenerative resistor power.
3	No resistor, using only capacitor	It is used when calculated value of maximum braking energy \leq maximum braking energy absorbed by capacitors.

Refer to section 5.1.4 to select a proper braking mode.

H02-26	Parameter Name	Power of external braking resistor			Property	At stop	Control Mode	PST
	Setting Range	1 to 65535	Unit	W	Effective Time	Immediate	Default	-

It sets the power of external regenerative resistor of the servo drive.

Note:
The setting of this parameter cannot be smaller than the braking power calculated value.

H02-27	Parameter Name	Resistance of external regenerative resistor			Property	At stop	Control Mode	PST
	Setting Range	1 to 1000	Unit	Ω	Effective Time	Immediate	Default	-

It sets the resistance of external regenerative resistor of the servo drive.

External regenerative resistor must be used when calculated value of maximum braking energy > maximum braking energy absorbed by capacitors and calculated value of braking power > built-in regenerative resistor power.

When the setting of H02-27 is too large, Er.920 (Regenerative resistor overload) or Er.400 (Main circuit overvoltage) will be detected.

When the setting of H02-27 is smaller than the setting of H02-21, Er.922 (Resistance of external braking resistor too small) will be detected. Continue use will damage the servo drive.

External regenerative resistor and built-in regenerative resistor cannot be used simultaneously. When using external regenerative resistor, remove the jumper link across terminals "P" and "D" and connect both ends to "P" and "C", respectively.

H02-30	Parameter Name	User Password			Property	At stop	Control Mode	PST
	Setting Range	0-65535	Unit	-	Effective Time	Power-on again	Default	0

It sets user password. Refer to section 4.4 for setting user password.

H02-31	Parameter Name	Parameter initialization			Property	At stop	Control Mode	PST
	Setting Range	0 to 2	Unit	-	Effective Time	Immediate	Default	0

It is used to restore parameter default setting or clear fault records.

Value	Operation	Description
0	No operation	-
1	Restore default setting	Restore parameter default setting except the parameters in groups H00 and H01.
2	Clear fault records	Clear faults and warnings for the recent 10 times.

If necessary, use the background software to back up parameters except the parameters in groups H00 and H01.

H02-32	Parameter Name	Default keypad display			Property	During running	Control Mode	-
	Setting Range	0 to 99	Unit	-	Effective Time	Immediate	Default	50

According to the setting, the keypad can switch over to monitoring parameter display mode (parameters in group H0B) automatically. H02-32 is used to set offset in H0B.

Value	Parameter in H0B	Description
0	H0B-00	Motor speed is not zero, the keypad displays the setting of H0B-00 (Actual motor speed).
1	H0B-01	The keypad displays the setting of H0B-01 (Speed reference).

If non-existent parameter is set, the keypad does not switch over to H0B parameter display.

H02-33	Parameter Name	EtherCAT firmware version			Property	At display	Control Mode	-
	Setting Range	-	Unit	-	Effective Time	-	Default	-

It displays the CANlink software version and has four decimals.

H02-34	Parameter Name	CAN firmware version			Property	At display	Control Mode	-
	Setting Range	-	Unit	-	Effective Time	-	Default	-

It displays the CANlink software version and has two decimals.

Group H03: Input Terminal Parameters

H03-00	Parameter Name	DI function (active after power-on) allocation 1			Property	During running	Control Mode	-
	Setting Range	0 to 0xFFFF	Unit	-	Effective Time	Power-on again	Default	0

It determines whether a digital input function (FunIN.1 to FunIN.16) becomes active immediately after power-on.

H03-00 is displayed in hexadecimal on the keypad. After converting to the decimal equivalent, bit(n) = 1 indicates that FunIN/(n+1) will become active after power-on.

H03-00 is input and displayed in decimal on background software.

For details of FunIN.1 to FunIN.16, refer to "DI/DO Function Definitions".

Value (HEX)	Effective Bit	DI Function to Become Active after Power-on	Function
0000	-	0	No function
0001	bit0	1	S-ON (Servo ON)
0002	bit1	2	ALM-RST (Fault and warning reset)
0004	bit2	3	GAIN-SEL (Gain switchover)
0008	bit3	4	CMD-SEL (Main/Auxiliary reference switchover)
0010	bit4	5	DIR-SEL (Multi-reference direction)
0020	bit5	6	CMD1 (Multi-reference switchover 1)
0040	bit6	7	CMD2 (Multi-reference switchover 2)
0080	bit7	8	CMD3 (Multi-reference switchover 3)
0100	bit8	9	CMD4 (Multi-reference switchover 4)
0200	bit9	10	M1-SEL (Mode switchover 1)
0400	bit10	11	M2-SEL (Mode switchover 2)
0800	bit11	12	ZCLAMP (Zero speed clamp)
1000	bit12	13	INHIBIT (Position reference inhibited)
2000	bit13	14	P-OT (Forward limit switch)
4000	bit14	15	P-OT (Reverse limit switch)
8000	bit15	16	P-CL (External positive torque limit)

Set H03-00 to the value recommended in the preceding table.

The setting of H03-00 cannot be duplicated with DI function allocation in group H03 and virtual DI function allocation in group H17. Otherwise, the setting of H03-00 is valid. Whether a DI function is active is determined by logic of the DI terminal that is set for this function in group H03 or H17.

Do not set DI terminal (edge valid) for the DI function (active after power-on), such as ALM-RST (fault and warning reset).

Do not set DI terminal that is switched over between active and inactive for the DI function (active after power-on).

H03-01	Parameter Name	DI function (active after power-on) allocation 2			Property	During running	Control Mode	-
	Setting Range	0 to 0xFFFF	Unit	-	Effective Time	Power-on again	Default	0

It determines whether a digital input function (FunIN.17 to FunIN.32) becomes active immediately after power-on.

H03-01 is displayed in hexadecimal on the keypad. After converting to the decimal equivalent, bit(n) = 1 indicates that FunIN/(n+1) will become active after power-on.

H03-01 is input and displayed in decimal on background software.

For details of FunIN.17 to FunIN.32, refer to "DI/DO Function Definitions".

Value (HEX)	Effective Bit	DI Function to Become Active after Power-on	Function
0000	-	0	No function
0001	bit0	17	N-CL (External negative torque limit)
0002	bit1	18	JOGCMD+ (Forward jog)
0004	bit2	19	JOGCMD- (Reverse jog)
0008	bit3	20	PosStep (Step reference)
0010	bit4	21	HX1 (Handwheel multiplying factor 1)
0020	bit5	22	HX1 (Handwheel multiplying factor 2)
0040	bit6	23	HX_EN (Handwheel signal)
0080	bit7	24	GEAR_SEL (Electronic gear ratio switchover)
0100	bit8	25	ToqDirSel (Torque reference direction selection)
0200	bit9	26	SpdDirSel (Speed reference direction selection)
0400	bit10	27	PosDirSel (Position reference direction selection)
0800	bit11	28	PosInSen (Multi-position reference enable)
1000	bit12	29	XintFree (Position change on fly unlock)
2000	bit13	30	-
4000	bit14	31	HomeSwitch (Home switch)
8000	bit15	32	HomingStart (Homing function)

Set H03-01 to the value recommended in the preceding table.

H03-02	Parameter Name	DI1 function selection			Property	During running	Control Mode	-
	Setting Range	0 to 37	Unit	-	Effective Time	At stop	Default	14

It sets DI1 for DI function.

For details of DI functions, refer to "DI/DO Function Definitions".

The DI functions are described in the following table.

Value	Function	Value	Function
0	No function	19	JOGCMD- (Reverse jog)
1	S-ON (Servo ON)	20	PosStep (Step reference)
2	ALM-RST (Fault and warning reset)	21	HX1 (Handwheel multiplying factor 1)
3	GAIN-SEL (Gain switchover)	22	HX1 (Handwheel multiplying factor 2)
4	CMD-SEL (Main/Auxiliary reference switchover)	23	HX_EN (Handwheel signal)
5	DIR-SEL (Multi-reference direction)	24	GEAR_SEL (Electronic gear ratio switchover)
6	CMD1 (Multi-reference switchover 1)	25	ToqDirSel (Torque reference direction selection)
7	CMD2 (Multi-reference switchover 2)	26	SpdDirSel (Speed reference direction selection)
8	CMD3 (Multi-reference switchover 3)	27	PosDirSel (Position reference direction selection)
9	CMD4 (Multi-reference switchover 4)	28	PosInSen (Multi-position reference enable)
10	M1-SEL (Mode switchover 1)	29	XintFree (Position change on fly unlock)
11	M2-SEL (Mode switchover 2)	30	-
12	ZCLAMP (Zero speed clamp)	31	HomeSwitch (Home switch)
13	INHIBIT (Position reference inhibited)	32	HomingStart (Homing function)
14	P-OT (Forward limit switch)	33	XintInhibit (Position change on fly inhibited)
15	P-OT (Reverse limit switch)	34	EmergencyStop (Emergency stop)
16	P-CL (External positive torque limit)	35	ClrPosErr (Position deviation cleared)
17	N-CL (External negative torque limit)	36	V_LmtSel (Internal speed limit source)
18	JOGCMD+ (Forward jog)	37	PulseInhibit (Pulse input inhibited)

Note:

Set H03-02 to the value in the preceding table.

Different DI terminals cannot be set for the same DI function. Otherwise, Er.130 (Different DIs allocated with the same function) will occur.

After a DI function is allocated to a DI terminal and the logic and the DI terminal is set to active, do not cancel the DI function allocation. Otherwise, the DI function will remain active.

DI1 to DI7 are low-speed DI terminals. The width of the input signal must be larger than 3 ms.

DI8 and DI9 are high-speed DI terminals. The width of the input signal must be larger than 0.25 ms.

The DI signal in the oscilloscope has been filtered (The filter time constant of low-speed DI terminals is 3 ms, and that of high-speed DI terminals is 0.25 ms). The signal, whose width is smaller than the filter time constant, is not displayed.

The servo drive forcibly sets DI9 as position change on fly switch. Do not set H03-18 for the other DI functions.

H03-03	Parameter Name	DI1 logic selection			Property	During running	Control Mode	-
	Setting Range	0 to 4	Unit	-	Effective Time	At stop	Default	0

It sets the DI1 logic when the DI function allocated to DI1 is enabled.

DI1 to DI7 are low-speed DI terminals. The width of the input signal must be larger than 3 ms. Set the valid logic correctly according to the host computer and peripheral circuits. The width of the input signal is shown in the following table.

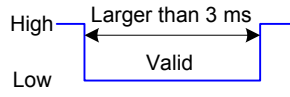
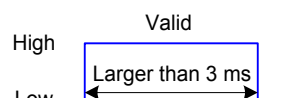
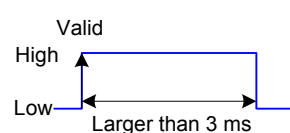
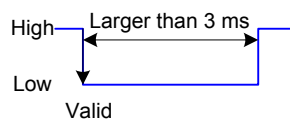
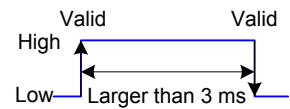
Value	DI1 Logic when DI1 Function Enabled	Description
0	Low level	
1	High level	
2	Rising edge	
3	Falling edge	
4	Rising edge and falling edge	

H03-04	Parameter Name	DI2 function selection			Property	During running	Control Mode	-
	Setting Range	0 to 37	Unit	-	Effective Time	At stop	Default	15

H03-05	Parameter Name	DI2 logic selection			Property	During running	Control Mode	-
	Setting Range	0 to 4	Unit	-	Effective Time	At stop	Default	0

H03-06	Parameter Name	DI3 function selection			Property	During running	Control Mode	-
	Setting Range	0 to 37	Unit	-	Effective Time	At stop	Default	13

H03-07	Parameter Name	DI3 logic selection			Property	During running	Control Mode	-
	Setting Range	0 to 4	Unit	-	Effective Time	At stop	Default	0

H03-08	Parameter Name	D14 function selection			Property	During running	Control Mode	-
	Setting Range	0 to 37	Unit	-	Effective Time	At stop	Default	2

H03-09	Parameter Name	D14 logic selection			Property	During running	Control Mode	-
	Setting Range	0 to 4	Unit	-	Effective Time	At stop	Default	0

H03-10	Parameter Name	D15 function selection			Property	During running	Control Mode	-
	Setting Range	0 to 37	Unit	-	Effective Time	At stop	Default	1

Set D15 for the required DI function.

The S-ON function must be allocated to a DI. Otherwise, the servo drive cannot operate. D15 is set for FunIN.1: S-ON by default.

H03-11	Parameter Name	D15 logic selection			Property	During running	Control Mode	-
	Setting Range	0 to 4	Unit	-	Effective Time	At stop	Default	0

It sets the D15 logic when the DI function allocated to D15 is enabled.

When a low-speed DI is set for S-ON, the valid signal width must be larger than H02-18 + 3 ms.

After you re-allocate the S-ON function, Er.941 (Parameter modification taking effect only after re-power-on) will occur. At this moment the servo drive must be re-powered on. Otherwise, the S-ON function is still determined by the VDI.

H03-12	Parameter Name	D16 function selection			Property	During running	Control Mode	-
	Setting Range	0 to 37	Unit	-	Effective Time	At stop	Default	12

H03-13	Parameter Name	D16 logic selection			Property	During running	Control Mode	-
	Setting Range	0 to 4	Unit	-	Effective Time	At stop	Default	0

H03-14	Parameter Name	D17 function selection			Property	During running	Control Mode	-
	Setting Range	0 to 37	Unit	-	Effective Time	At stop	Default	3

H03-15	Parameter Name	D17 logic selection			Property	During running	Control Mode	-
	Setting Range	0 to 4	Unit	-	Effective Time	At stop	Default	0

H03-16	Parameter Name	DI8 function selection			Property	During running	Control Mode	-
	Setting Range	0 to 37	Unit	-	Effective Time	At stop	Default	31

Set DI8 for the required DI function.

H03-17	Parameter Name	DI8 logic selection			Property	During running	Control Mode	-
	Setting Range	0 to 4	Unit	-	Effective Time	At stop	Default	0

It sets the DI8 logic when the DI function allocated to DI8 is enabled.

DI8 and DI9 are high-speed DI terminals. The width of the input signal must be larger than 0.25 ms. Set the valid logic correctly according to the host computer and peripheral circuits. The width of the input signal is shown in the following table.

Value	DI1 logic when DI1 Function Enabled	Description
0	Low level	
1	High level	
2	Rising edge	
3	Falling edge	
4	Rising edge and falling edge	

7

H03-18	Parameter Name	DI9 function selection			Property	During running	Control Mode	-
	Setting Range	0 to 37	Unit	-	Effective Time	At stop	Default	0

Set DI9 for the required DI function.

H03-19	Parameter Name	DI9 logic selection			Property	During running	Control Mode	-
	Setting Range	0 to 4	Unit	-	Effective Time	At stop	Default	0

It sets the DI9 logic when the DI function allocated to DI9 is enabled.

The servo drive forcibly sets DI9 as position change on fly switch. Do not set H03-18 for the other DI functions. Otherwise, Er.130 will occur. At this moment, the DI9 logic is edge valid.

H03-34	Parameter Name	DI function (active after power-on) allocation 3			Property	During running	Control Mode	-
	Setting Range	0 to 0xFFFF	Unit	-	Effective Time	Power-on again	Default	0

It determines whether a digital input function (FunIN.33 to FunIN.37) becomes active immediately after power-on.

H03-34 is displayed in hexadecimal on the keypad. After converting to the decimal equivalent, bit(n) = 1 indicates that FunIN/(n+1) will become active after power-on.

H03-34 is input and displayed in decimal on background software. Please remember data conversion during the use.

For details of FunIN.33 to FunIN.37, refer to "DI/DO Function Defintions".

The setting values of H03-34 are described in the following table.

Value (HEX)	Effective Bit	DI Function to Become Active After Power-on	Function
0000	None	0	No DI function allocated
0001	bit0	33	XintInhibit (Position change on fly inhibited)
0002	bit1	34	EmergencyStop (Emergency stop)
0004	bit2	35	ClrPosErr (position deviation cleared)
0008	bit3	36	V_LmtSel (Internal speed limit source)
0010	bit4	37	PulseInhibit (Pulse input inhibited)
0020	bit5	38	-
0040	bit6	39	-
0080	bit7	40	-
0100	bit8	41	-
0200	bit9	42	-
0400	bit10	43	-
0800	bit11	44	-
1000	bit12	45	-
2000	bit13	46	-
4000	bit14	47	-
8000	bit15	48	-

Set H03-34 to the value recommended in the preceding table.

H03-35	Parameter Name	DI function (active after power-on) allocation 4			Property	During running	Control Mode	-
	Setting Range	0 to 0xFFFF	Unit	-	Effective Time	Power-on again	Default	0

It sets any digital input function (FunIN.49 to FunIN.64) to become active immediately after power-on. H03-35 is displayed in hexadecimal on the keypad. After converting to the decimal equivalent, bit(n) = 1 indicates that FunIN/(n+1) will become active after power-on. H03-34 is input and displayed in decimal on background software. Please remember data conversion during the use.

The setting values of H03-35 are described in the following table.

Value (HEX)	Effective Bit	DI Function to Become Active After Power-on	Function
0000	None	0 No DI function allocated	None
0001	bit0	49	
0002	bit1	50	
0004	bit2	51	
0008	bit3	52	
0010	bit4	53	
0020	bit5	54	
0040	bit6	55	
0080	bit7	56	
0100	bit8	57	
0200	bit9	58	
0400	bit10	59	
0800	bit11	60	
1000	bit12	61	
2000	bit13	62	
4000	bit14	63	
8000	bit15	64	

Set H03-35 to the value recommended in the preceding table.

H03-50	Parameter Name	AI1 offset			Property	During running	Control Mode	-
	Setting Range	-5000 to 5000	Unit	mV	Effective Time	Immediate	Default	0

It sets the actual AI1 input voltage when the drive sampling voltage is 0 after zero drift correction.

H03-51	Parameter Name	AI1 filter time constant			Property	During running	Control Mode	-
	Setting Range	0 to 655.35	Unit	ms	Effective Time	Immediate	Default	2.00

It sets the filter time constant of voltage signal input from AI1.

The setting of this parameter can avoid motor reference fluctuation caused by instable voltage input and reduce motor maloperations caused by interference signal.

The filter function cannot eliminate or suppress zero drift and dead zone.

H03-53	Parameter Name	AI1 dead zone			Property	During running	Control Mode	-
	Setting Range	0 to 1000.0	Unit	mV	Effective Time	Immediate	Default	10.0

It sets the AI1 input voltage range when the drive sampling voltage is 0.

H03-54	Parameter Name	AI1 zero drift			Property	During running	Control Mode	-
	Setting Range	-500.0 to 500.0	Unit	mV	Effective Time	Immediate	Default	0.0

Zero drift: indicates the value of the servo drive sampling voltage relative to GND.

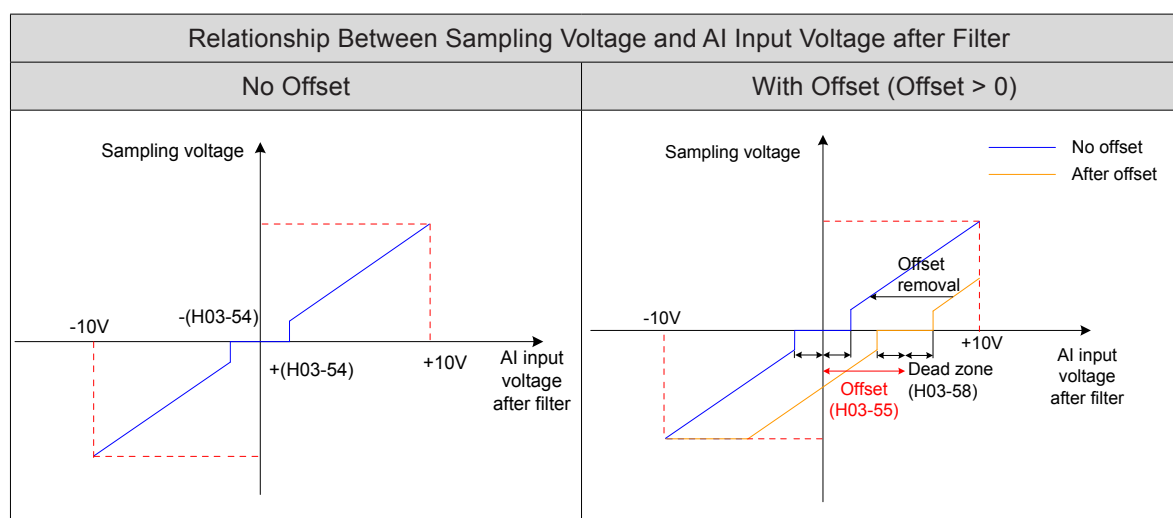

Set H0D-10 (Analog automatic adjustment) = 1 (AI1 adjustment) to perform automatic adjustment of AI1 zero drift. The adjusted AI1 zero drift will be restored in H03-54.

If zero drift is larger than 500.0 mV, Er.831 (AI zero drift too large) will occur.

If sampling voltage is larger than 11.5 V, Er.834 (AD sampling overvoltage) will occur.

In torque control, if the torque reference source is analog voltage, refer to section 5.4.1 for details on the setting of AI1.

H03-55	Parameter Name	AI2 offset			Property	During running	Control Mode	-
	Setting Range	-5000 to 5000	Unit	mV	Effective Time	Immediate	Default	0

H03-56	Parameter Name	AI2 filter time constant			Property	During running	Control Mode	-
	Setting Range	0 to 655.35	Unit	ms	Effective Time	Immediate	Default	2.00

H03-58	Parameter Name	AI2 dead zone			Property	During running	Control Mode	-
	Setting Range	0 to 1000.0	Unit	mV	Effective Time	Immediate	Default	10.0

H03-59	Parameter Name	AI2 zero drift			Property	During running	Control Mode	-
	Setting Range	-500.0 to 500.0	Unit	mV	Effective Time	Immediate	Default	0.0

H03-80	Parameter Name	Speed corresponding to 10 V			Property	At stop	Control Mode	-
	Setting Range	0 to 6000	Unit	RPM	Effective Time	Immediate	Default	3000

It set corresponding motor speed when sampling voltage is 10 V,

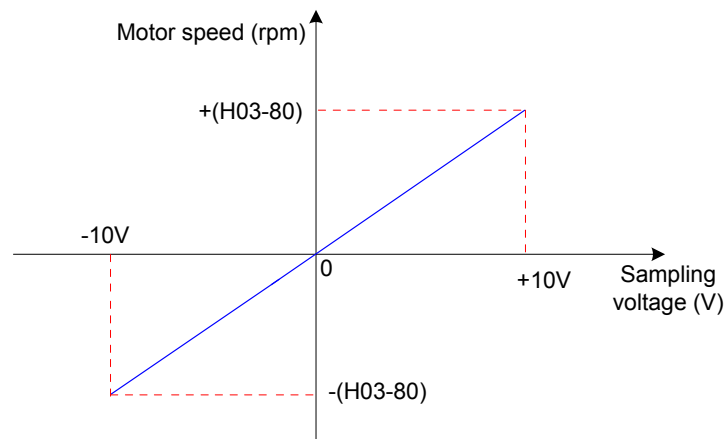

$$\text{Speed reference} = \frac{\text{Sampling voltage}}{10} \times (\text{H03-80})$$

When speed feedforward is used and feedforward source is AI1 or AI2 (H05-19 = 2 or 3) in position control.

When speed reference source is AI (H06-00/H06-01 = 1 or 2) in speed control.

When speed limit source is AI (H07-18 = 1 or 2) in torque control.

H03-81	Parameter Name	Torque corresponding to 10 V			Property	At stop	Control Mode	-
	Setting Range	1.00 to 8.00	Unit	times	Effective Time	Immediate	Default	1.00

It sets the torque level corresponding to sampling voltage 10 V.

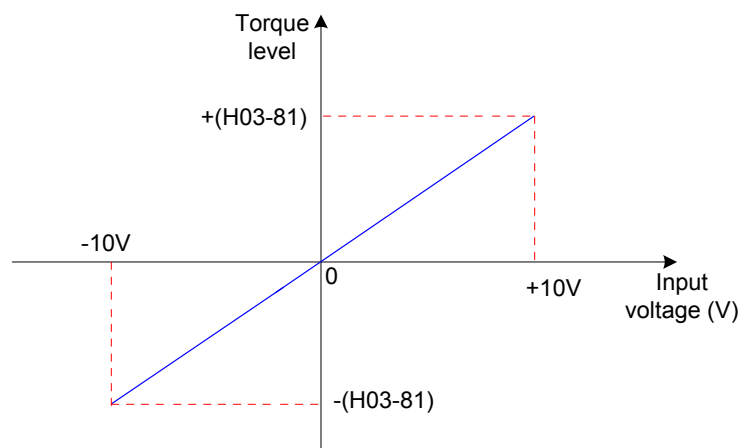

$$\text{Torque reference} = \frac{\text{Sampling voltage}}{10} \times (\text{H03-81})$$

When torque reference source is AI (H07-00/H07-01 = 1 or 2) in speed control.

When torque limit source is AI (H07-08 = 1 or 2) in torque control.

1.00 time indicates one time of rated motor torque.

Group H04: Output Terminal Parameters

H04-00	Parameter Name	DO1 function selection			Property	During running	Control Mode	-
	Setting Range	0 to 19	Unit	-	Effective Time	At stop	Default	1

It sets DO1 for the required DO function.

For details of DO functions, refer to "DI/DO Function Definitions".

The DO functions are described in the following table.

Value	DO Function
0	No function
1	S-RDY (Servo ready)
2	TGON (Motor rotation output)
3	ZERO (Zero speed signal)
4	V-CMP (Speed consistent)
5	COIN (Positioning completed)
6	NEAR (Positioning near)
7	C-LT (Torque limit)
8	V-LT (Speed limit)
9	BK (Brake output)
10	WARN (Warning output)
11	ALM (Fault output)
12	ALMO1 (3-digit fault code output)
13	ALMO2 (3-digit fault code output)
14	ALMO3 (3-digit fault code output)
15	Xintcoin (Position change on fly completed)
16	Home Attain (Home attaining output)
17	ElecHomeAttain (Electrical home attaining output)
18	ToqReach (Torque reached)
19	V-Arr (Speed reached)

Set H04-00 to the value recommended in the preceding table.

Do not set different DO terminals including DO and VDO for the same DO function.

H04-01	Parameter Name	DO1 logic selection			Property	During running	Control Mode	-
	Setting Range	0 to 1	Unit	-	Effective Time	At stop	Default	0

It sets the DO1 logic when DO function allocated to DO1 is enabled.

DO1 to DO5 are low-speed DO terminals and the output signal width is 1 ms at minimum. The host computer must have correct design and ensure that valid DO logic change is received.

Value	DO1 Logic when DO1 Function Enabled	Transistor State	Min. Signal Width
0	Low level	ON	
1	High level	OFF	

View the setting of H04-22 (DO source) before receiving DO logic change to check whether DO output level is determined by the drive status or communication.

H04-02	Parameter Name	DO2 function selection			Property	During running	Control Mode	-
	Setting Range	0 to 19	Unit	-	Effective Time	At stop	Default	5

H04-03	Parameter Name	DO2 logic selection			Property	During running	Control Mode	-
	Setting Range	0 to 1	Unit	-	Effective Time	At stop	Default	0

H04-04	Parameter Name	DO3 function selection			Property	During running	Control Mode	-
	Setting Range	0 to 19	Unit	-	Effective Time	At stop	Default	3

H04-05	Parameter Name	DO3 logic selection			Property	During running	Control Mode	-
	Setting Range	0 to 1	Unit	-	Effective Time	At stop	Default	0

H04-06	Parameter Name	DO4 function selection			Property	During running	Control Mode	-
	Setting Range	0 to 19	Unit	-	Effective Time	At stop	Default	11

H04-07	Parameter Name	DO4 logic selection			Property	During running	Control Mode	-
	Setting Range	0 to 1	Unit	-	Effective Time	At stop	Default	0

H04-08	Parameter Name	DO5 function selection			Property	During running	Control Mode	-
	Setting Range	0 to 19	Unit	-	Effective Time	At stop	Default	16

H04-09	Parameter Name	DO5 logic selection			Property	During running	Control Mode	-
	Setting Range	0 to 1	Unit	-	Effective Time	At stop	Default	0

H04-22	Parameter Name	DO source			Property	At stop	Control Mode	-
	Setting Range	0 to 31	Unit	-	Effective Time	Immediate	Default	0

It sets whether the logic of DO terminals is determined by the drive status or communication.

H04-22 is displayed in decimal on the keypad. After converting to binary,

Bit(n) = 0 in H04-22 indicates that DO (n+1) logic is determined by the drive status.

Bit(n) = 1 in H04-22 indicates that DO(n+1) logic is determined by communication (H31-04).

Value (Decimal)	Value (Binary)					DO Logic Determined by	
	bit4	bit3	bit2	bit1	bit0	Drive Status	Communication (H31-04)
	DO5	DO4	DO3	DO2	DO1		
0	0	0	0	0	0	DO1 to DO5	None
1	0	0	0	0	1	DO2 to DO5	DO1
...
31	1	1	1	1	1	None	DO1 to DO5

Set H04-22 to the value recommended in the preceding table.

Be cautious of determining logic of the DO terminal set for function FunOUT.9:BK by communication.

Use DO according to the following procedure.

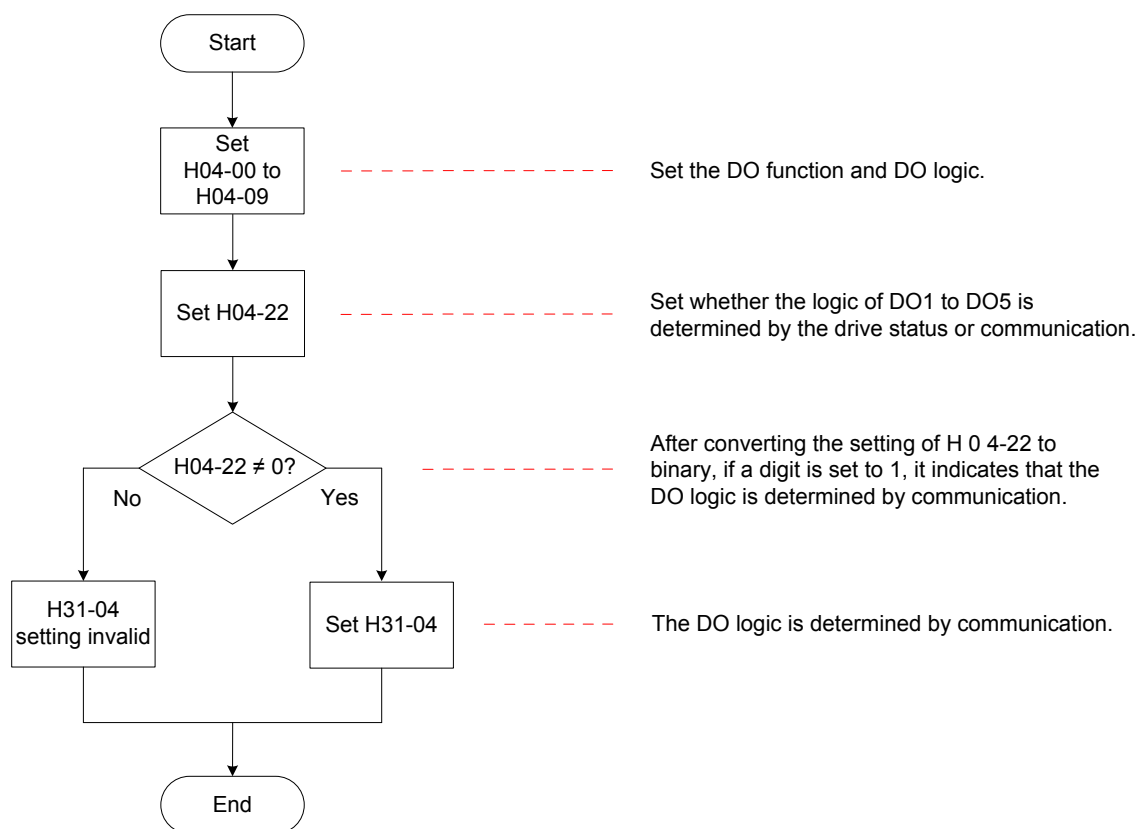

H31-04 is invisible on the keypad and can only be modified via communication.

Bit(n) = 1 in H31-04 indicates that DO(n+1) logic is valid. Bit(n) = 0 in H31-04 indicates that DO(n+1) logic is invalid.

The DO output state can be read via monitoring parameter (H0B-05).

H04-50	Parameter Name	AO1 signal selection			Property	During running	Control Mode	-
	Setting Range	0 to 9	Unit	-	Effective Time	Immediate	Default	0
It sets the AO1 output signal.								
Value	AO1 Signal	Description						
0	Motor speed (1 V/1000 RPM)	When actual motor speed is 1000 RPM, the AO1 output voltage in 1 V in theory.						
1	Speed reference (1 V/1000 RPM)	The motor speed reference indicates the speed loop input reference, including: Position loop output in position control Speed reference in speed control When speed reference is 1000 RPM, AO1 output voltage in 1 V in theory.						
2	Torque reference (1 V/1 time of rated motor torque)	Motor torque reference, including: Speed loop output in position or speed control Torque reference in torque control When torque reference is one time of rated motor torque, AO1 output voltage is 1 V in theory.						
3	Position deviation (0.05 V/1 reference unit)	Position deviation without electronic gear ratio When position deviation is one reference unit, AO1 output voltage is 0.05 V in theory.						
4	Position deviation (0.05 V/1 encoder unit)	Position deviation with electronic gear ratio When position deviation is one encoder unit, AO1 output voltage is 0.05 V in theory.						
5	Position reference speed (1 V/1000 RPM)	It indicates the motor speed corresponding to the position reference output by each position loop cyclically in position control. When speed reference is 1000 RPM, AO1 output voltage in 1 V in theory. The time constant of position reference speed filter can be set in H0A-27.						
6	Positioning completed	Positioning completed (COIN) signal Active: AO1 output voltage is 5 V. Inactive: AO1 output voltage is 0 V.						
7	Speed feedforward (1 V/1000 RPM)	In position control, the output signal of speed feedforward control corresponds to some speed reference sources. When speed reference of speed feedforward control output is 1000 RPM, AO1 output voltage is 1 V in theory.						
8	AI1 voltage	AI1 sampling voltage						
9	AI2 voltage	AI2 sampling voltage						

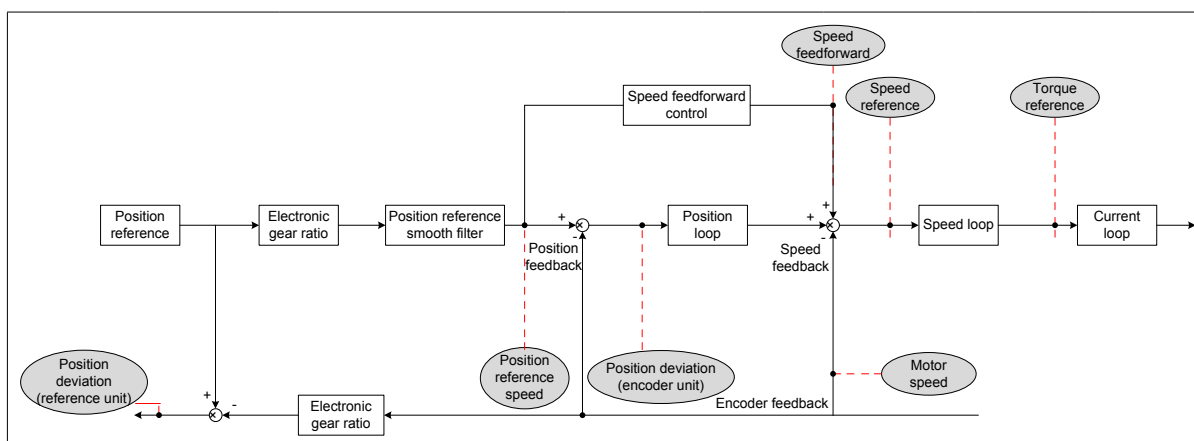

H04-51	Parameter Name	AO1 offset voltage			Property	During running	Control Mode	-
	Setting Range	-10000 to 10000	Unit	mV	Effective Time	Immediate	Default	5000

It sets the actual AO1 output voltage after offset when theoretical output voltage is 0 V.

H04-52	Parameter Name	AO1 multiplying factor			Property	During running	Control Mode	-
	Setting Range	-99.99 to 99.99	Unit	times	Effective Time	Immediate	Default	1.00

It sets the actual AO1 output voltage after amplification when theoretical output voltage is 1V.

For example, H04-50 = 0 (AO1 output is motor speed).

We pre-design when motor speed x varies between -3000 to 3000 RPM, the range of AO1 output voltage y is 0 to 5000 mV.

$$\begin{cases} -3000 \times k + b = 0 \\ 3000 \times k + b = 5000 \end{cases}$$

In the preceding formula, k = 0.83 and b = 2500. Thus H04-51 = 2500 (mV) and H04-52 = 0.83 (time).

H04-53	Parameter Name	AO2 signal selection			Property	During running	Control Mode	-
	Setting Range	0 to 9	Unit	-	Effective Time	Immediate	Default	0

H04-54	Parameter Name	AO2 offset voltage			Property	During running	Control Mode	-
	Setting Range	-10000 to 10000	Unit	mV	Effective Time	Immediate	Default	5000

H04-55	Parameter Name	AO2 multiplying factor			Property	During running	Control Mode	-
	Setting Range	-99.99 to 99.99	Unit	times	Effective Time	Immediate	Default	1.00

Group H05: Position Control Parameters

H05-00	Parameter Name	Position reference source			Property	At stop	Control Mode	P
	Setting Range	0 to 2	Unit	-	Effective Time	Immediate	Default	0

It selects the position reference source in position control.

Value	Meaning	Description
0	Pulse input	Host computer or another pulse generator generates pulses, which is input into the servo drive via hardware terminal. The hardware terminal is selected in H05-01.
1	Step setting	The step setting is set in H05-05. The step reference is sent by the DI set for function FunIN.20.
2	Multi-position reference	The running mode of the multi-position function is set in parameters in group H11. The multi-position reference is sent by the DI set for function FunIN.28.

The pulse input is external position reference. The step reference and multi-position reference are internal position references.

H05-01	Parameter Name	Pulse input terminal selection			Property	At stop	Control Mode	P
	Setting Range	0, 1	Unit	-	Effective Time	Immediate	Default	0

It selects the hardware input terminal according to input pulse frequency when H05-00 = 0 (position reference source is pulse input) in position control.

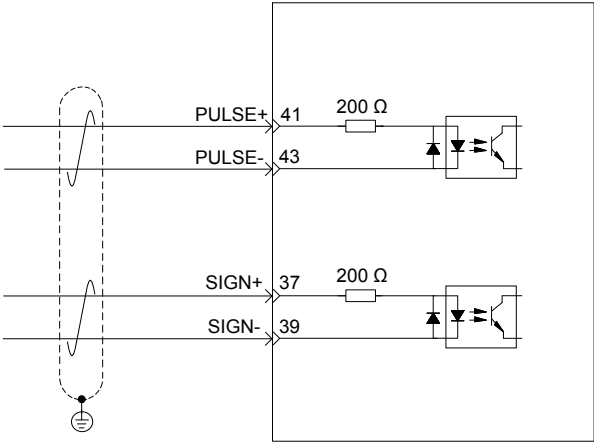
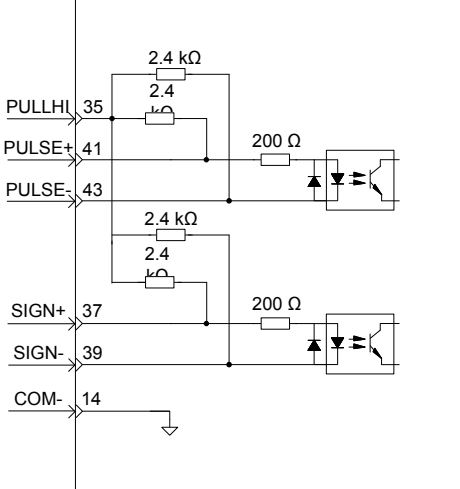
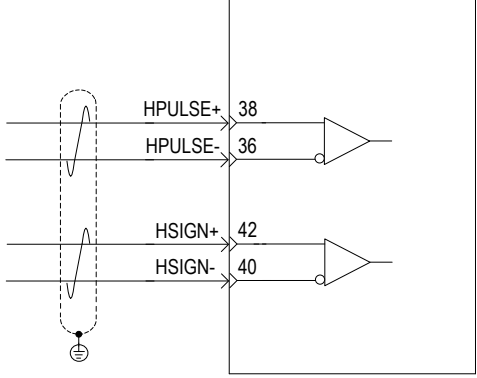
Value	Input Terminal	Hardware Interface
0	Low-speed terminals	<p>Differential input terminals, PULSE+, PULSE-, SIGN+, SIGN-</p> <p style="text-align: center;">Servo drive</p>  <p>Max. pulse frequency: 500 kpps</p> <p>Open-collector input terminals, PULLHI, PULSE+, PULSE-, SIGN+, SIGN-</p> <p style="text-align: center;">Servo drive</p>  <p>Max. pulse frequency: 200 kpps</p>
1	High-speed terminals	<p>Differential input terminals: HPULSE+, HPULSE-, HSIGN+, HSIGN-</p> <p style="text-align: center;">Servo drive</p>  <p>Max. pulse frequency: 4 Mpps</p>

H05-02	Parameter Name	Pulses per one motor revolution			Property	At stop	Control Mode	P
	Setting Range	0 to 1048576	Unit	P/r	Effective Time	Power-on again	Default	0

It set the number of pulses required for one motor revolution

When H05-02 = 0, electronic gear ratio 1 and electronic gear ratio 2 (H05-07 to H05-13) and electronic gear ratio switchover condition (H05-39) are valid.

$$\text{When } H05-02 \neq 0, \quad \text{Electronic gear ratio } \frac{B}{A} = \frac{\text{Motor resolution}}{H05-02} .$$

In this case, electronic gear ratio 1 and electronic gear ratio 2 are invalid.

The encoder resolution is 1048576P/r.

H05-04	Parameter Name	Time constant of first-order low-pass filter			Property	At stop	Control Mode	P
	Setting Range	0 to 6553.5	Unit	ms	Effective Time	Immediate	Default	0.0

It sets the time constant of first-order low-pass filter for position reference (encoder unit).

If position reference P is rectangular wave or trapezoidal wave, the position reference after first-order low-pass filter is as follows:

This function has no effect on displacement (position reference sum).

Too large setting of this parameter will cause an increase in response delay. Set this parameter correctly according to actual condition.

H05-05	Parameter Name	Step amount			Property	At stop	Control Mode	P
	Setting Range	-9999 to 9999	Unit	Reference unit	Effective Time	Immediate	Default	50

It sets position reference sum when H05-00 = 1 (position reference source is step setting).

Motor displacement = H05-05 x electronic gear ratio. Positive/negative of the setting of H05-05 decides forward/reverse rotation of the motor.

H05-06	Parameter Name	Time constant of moving average filter			Property	At stop	Control Mode	P
	Setting Range	0 to 128.0	Unit	ms	Effective Time	Immediate	Default	0.0

It sets the time constant of moving average filter for position references (encoder unit). If position reference P is rectangular wave or trapezoidal wave, the position reference after filter of average value is as follows:

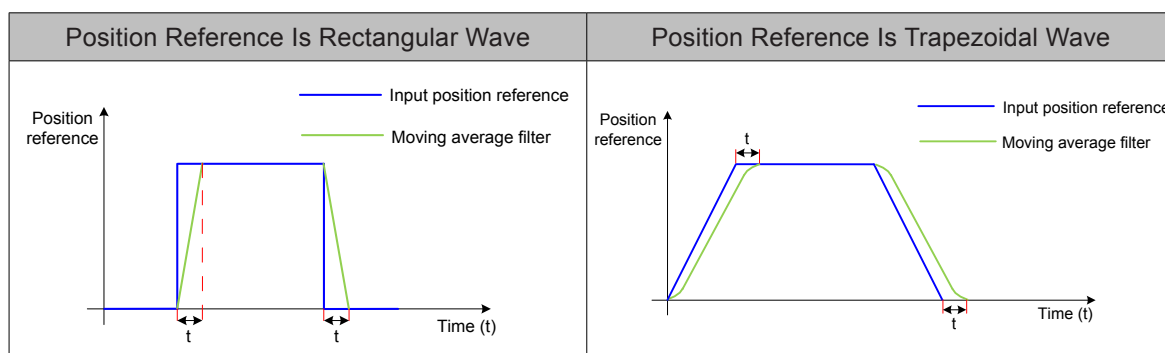

This function has no effect on displacement (position reference sum). Too large setting of this parameter will cause an increase in response delay. Set this parameter correctly according to actual condition.

H05-07	Parameter Name	Electronic gear ratio 1 (numerator)			Property	During running	Control Mode	P
	Setting Range	1 to 1073741824	Unit	-	Effective Time	Immediate	Default	1048576

It sets the numerator of electronic gear ratio 1 for frequency-division/multiplication of position reference (reference unit).

It is valid when H05-02 (Pulses per one motor revolution) = 0.

H05-09	Parameter Name	Electronic gear ratio 1 (denominator)			Property	During running	Control Mode	P
	Setting Range	1 to 1073741824	Unit	-	Effective Time	Immediate	Default	10000

For the IS620P servo drive, the default value is 10000. For the IS600P servo drive, the default value is 1.

It sets the denominator of electronic gear ratio 1 for frequency-division/multiplication of position reference (reference unit).

It is valid when H05-02 (Pulses per one motor revolution) = 0.

H05-11	Parameter Name	Electronic gear ratio 2 (numerator)			Property	During running	Control Mode	P
	Setting Range	1 to 1073741824	Unit	-	Effective Time	Immediate	Default	1048576

It sets the numerator of electronic gear ratio 2 for frequency-division/multiplication of position reference (reference unit).

It is valid when H05-02 (Pulses per one motor revolution) = 0.

H05-13	Parameter Name	Electronic gear ratio 2 (denominator)			Property	During running	Control Mode	P
	Setting Range	1 to 1073741824	Unit	-	Effective Time	Immediate	Default	10000
<p>It sets the denominator of electronic gear ratio 2 for frequency-division/multiplication of position reference (reference unit).</p> <p>It is valid when H05-02 (Pulses per one motor revolution) = 0.</p>								
H05-15	Parameter Name	Pulse input format			Property	At stop	Control Mode	P
	Setting Range	0 to 3	Unit	-	Effective Time	Power-off again	Default	0

It sets the input pulse format when H05-00 = 0 (position reference source is pulse input).
 Maximum frequency and minimum time width of pulse position reference corresponding to different input terminals are as follows:

Setting of H02-02	Setting of H05-15	Pulse Form	Signal	Forward Pulse Diagram	Reverse Pulse Diagram
0	0	Pulse + direction, positive logic	PULSE SIGN		
	1	Pulse + direction, negative logic	PULSE SIGN		
	2	Phase A + phase B quadrature pulse, 4-frequency multiplication	PULSE (phase A) SIGN (phase B)		
	3	CW + CCW	PULSE (CW) SIGN (CCW)		
1	0	Pulse + direction positive logic	PULSE SIGN		
	1	Pulse + direction, negative logic	PULSE SIGN		
	2	Phase A + phase B quadrature pulse, 4-frequency multiplication	PULSE (phase A) SIGN (phase B)		
	3	CW + CCW	PULSE (CW) SIGN (CCW)		

Input Terminals		Max. Frequency	Min. Time Width/us					
			t1	t2	t3	t4	t5	t6
High-speed pulse input terminal		4Mpps	0.125	0.125	0.125	0.25	0.125	0.125
Low-speed pulse input terminal	Differential input	500kpps	1	1	1	2	1	1
	Open-collector input	200kpps	2.5	2.5	2.5	5	2.5	2.5

The rise time and fall time of pulse position reference should be smaller than 0.1 us.

H05-16	Parameter Name	Clear action			Property	At stop	Control Mode	P
	Setting Range	0 to 2	Unit	-	Effective Time	Immediate	Default	0

It sets the condition of clearing position deviation.

Position deviation = (position reference – position feedback) (encoder unit)

Value	Clearing Condition	Description
0	Clear position deviation when S-ON is turned off or a fault occurs.	
1	Clear position deviation pulses when S-ON is turned off or a fault occurs.	
2	Clear position deviation when S-ON is turned off and the ClrPosErr signal is input from DI.	<p>Set a DI terminal for FunIN.35: ClrPosErr (Position deviation cleared). It is recommended that high-speed DI terminal be set for this function and the logic be edge valid.</p> <p>(Rising edge valid)</p>
		<p>(Falling edge valid)</p>

If absolute value of position deviation is larger than H0A-10 (Threshold of position deviation excess), Er.B00 (Position deviation being large) will occur.

H05-17	Parameter Name	Encoder frequency-division pulses			Property	At stop	Control Mode	-
	Setting Range	35 to 32767	Unit	P/r	Effective Time	Power-on again	Default	2500

It sets the number of pulses output by PAO or PBO per motor revolution.
 After quadruple frequency, the pulse output resolution is:
 Pulse output resolution per motor revolution = H05-17 x 4

H05-19	Parameter Name	Speed feedforward control selection			Property	At stop	Control Mode	P
	Setting Range	0 to 3	Unit	-	Effective Time	Immediate	Default	1

It sets the speed loop feedforward signal source.
 Adopting speed feedforward control can improve position reference response in position control.

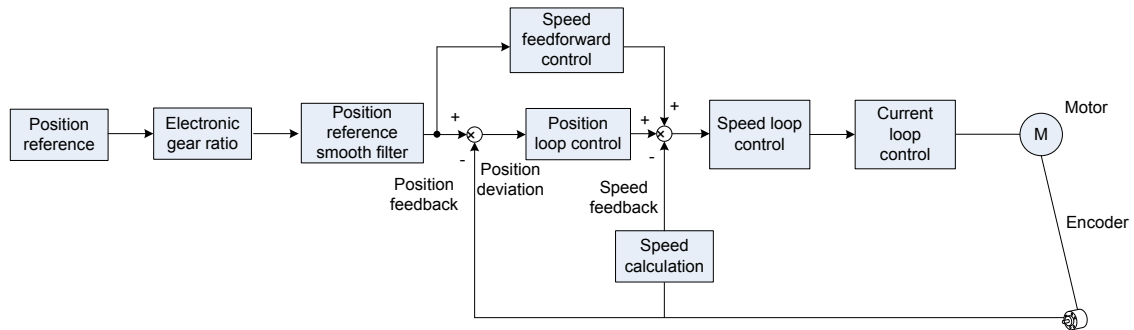

Value	Meaning	Description
0	No speed feedforward	-
1	Internal	Use speed corresponding to position reference (encoder unit) as speed feedforward source.
2	AI1	Use speed corresponding to analog input of AI1 as speed feedforward source. For setting of AI1, see H03-80, H03-50, H03-51, H03-53 and H03-54.
3	AI2	Use speed corresponding to analog input of AI2 as speed feedforward source. For setting of AI2, see H03-80, H03-55, H03-56, H03-58 and H03-59.

For speed feedforward control parameters including H08-18 (Time constant of speed feedforward filter) and H08-19 (Speed feedforward gain), refer to chapter 6.

H05-20	Parameter Name	Output condition of positioning completed/near signal (COIN/NEAR)			Property	At stop	Control Mode	P
	Setting Range	0 to 2	Unit	-	Effective Time	Immediate	Default	0

When the absolute value of the position deviation is within H05-21/H05-22 during drive running in position control, the servo drive outputs positioning completed signal (FunOUT.5: COIN) or positioning near signal (FunOUT.6: NEAR) signal.

Value	Output Condition
0	Absolute value of position deviation is smaller than H05-21/H05-22
1	Absolute value of position deviation is smaller than H05-21/H05-22 and position reference after filter is 0
2	Absolute value of position deviation is smaller than H05-21/H05-22 and position reference before filter is 0

H05-21	Parameter Name	Threshold of positioning completed			Property	During running	Control Mode	P
	Setting Range	1 to 65535	Unit	Encoder unit	Effective Time	Immediate	Default	734

It sets the absolute threshold of the position deviation when servo drive outputs positioning completed signal.

Positioning completed signal: FunOUT.5: COIN

The positioning completed signal is valid only when the servo drive is in running status in position control.

H05-22	Parameter Name	Threshold of positioning near			Property	During running	Control Mode	P
	Setting Range	1 to 65535	Unit	Encoder unit	Effective Time	Immediate	Default	65535

It sets the absolute threshold of the position deviation when servo drive outputs positioning near signal.

Positioning near signal: FunOUT.6: NEAR

Note:

The setting of H05-22 must be larger than that of H05-21 normally.

H05-21 (Threshold of positioning completed) indicates threshold of position deviation absolute when positioning completed is valid. It is unrelated to positioning accuracy.

Too large setting of H8-19 (Speed feedforward gain) or drive running at low speed will result in small position deviation absolute value. If the setting of H05-21 is too large, positioning completed will be always valid. In this case, decrease the setting of H05-21 to improve efficiency of positioning completed.

On the condition that the setting of H05-21 is small and position deviation is also small, change output condition of positioning completed signal by setting H05-20.

H05-23	Parameter Name	Position change on fly			Property	At stop	Control Mode	P
	Setting Range	0 to 1	Unit	-	Effective Time	Power-on again	Default	0

It sets whether to enable position change on fly.

Value	Meaning
0	Disabled
1	Enabled

When using this function, DI9 is forcibly used for input the position change on fly signal and its logic is edge valid.

When the homing function is enabled, the position change on fly signal is shielded.

When position change on fly is enabled, the other internal and external position references are shielded. Once it is disabled, the condition of responding to the other position references is determined by the setting of H05-29.

H05-24	Parameter Name	Displacement of position change on fly			Property	During running	Control Mode	P
	Setting Range	0 to 1073741824	Unit	Reference unit	Effective Time	Immediate	Default	10000

It sets the position reference for position change on fly.

If H05-24 = 0, the position change on fly function is disabled.

Actual position reference (encoder unit) for position change on fly = H05-24 x electronic gear ratio

If position deviation is very large before position change on fly is enabled and the setting of H05-24 is too small, reverse motor rotation will occur.

H05-26	Parameter Name	Constant speed for position change on fly			Property	During running	Control Mode	P
	Setting Range	0 to 6000	Unit	RPM	Effective Time	Immediate	Default	200

It sets maximum motor speed for position change on fly.

Value	Motor Speed Before Enabling Position Change on Fly	Max. Speed for Position Change on Fly	Motor Rotating Direction for Position Change on Fly
0	< 1	1	-
	≥ 1	Motor speed before enabling position change on fly	Consistent with motor rotating direction before enabling position change on fly
1 to 6000	-	Setting of H05-26	Determined by H02-02 (rotating direction selection)

H05-27	Parameter Name	Acceleration/Deceleration time of position change on fly			Property	During running	Control Mode	P
	Setting Range	0 to 1000	Unit	ms	Effective Time	Immediate	Default	10

It sets the time for motor to accelerate from 0 to 1000 RPM or decelerate from 1000 RPM to 0 for position change on fly.

Thus actual motor acceleration time "t" during position change on fly is:

$$t = \frac{|H05-26 - \text{motor speed before enabling position change on fly}|}{1000} \times (H05-27)$$

H05-29	Parameter Name	Position change on fly unlock			Property	During running	Control Mode	P
	Setting Range	0 to 1	Unit	-	Effective Time	Immediate	Default	1

It sets whether to unlock position change on fly signal.

Value	Meaning	Description
0	Disabled	After the running of position change on fly is completed, the servo drive directly responds to the other position references.
1	Enabled	After the running of position change on fly is completed, the servo drive does not respond to the other position references. After you enable the DI function (FunIN.29: XintFree, position change on fly unlock), the servo drive can respond to the other position references.

Note:

Set H05-29 = 1 normally, which helps to prevent motor maloperation due to input of interference position reference after positioning of position change on fly is completed.

H05-30	Parameter Name	Homing enabling method			Property	During running	Control Mode	P
	Setting Range	0 to 6	Unit	-	Effective Time	Immediate	Default	0

It sets the method of enabling the homing function.

Value	Description	Description	
		Homing	Signal Source
0	Disabled	The homing function is disabled.	
1	Input HomingStart signal from DI to enable homing	Home attaining	DI function FunIN.32: HomingStart, homing function
2	Input HomingStart signal from DI to enable electrical home attaining	Electrical home attaining	DI function FunIN.32: HomingStart, homing function
3	Start homing immediately upon power-on	Home attaining	S-ON signal active for the first time after power-on again in position control
4	Perform homing immediately	Home attaining	S-ON signal active in position control After the operation is successful, set H05-30 = 0.
5	Start electrical home attaining	Electrical home attaining	S-ON signal in position control After the operation is successful, set H05-30 = 0.
6	Take current position as the home	Home attaining	The signal is not required. After the operation is successful, set H05-30 = 0.

For details on the homing function, refer to section 5.2.8.

H05-31	Parameter Name	Homing mode			Property	At stop	Control Mode	P
	Setting Range	0 to 9	Unit	-	Effective Time	Immediate	Default	0

It sets the default motor rotating direction, deceleration point and home for home attaining.

Value	Homing Mode			Remark
	Actuation Direction	Deceleration Point	Home	
0	Forward	Home switch	Home switch	Forward/Reverse: consistent with the setting of H02-02 (rotating direction selection) Home switch: DI function FunIN.31: HomeSwitch Forward limit switch: DI function FunIN.14 :P-OT Reverse limit switch: DI function FunIN.15: N-OT
1	Reverse	Home switch	Home switch	
2	Forward	Motor Z signal	Motor Z signal	
3	Reverse	Motor Z signal	Motor Z signal	
4	Forward	Home switch	Motor Z signal	
5	Reverse	Home switch	Motor Z signal	
6	Forward	Forward limit switch	Forward limit switch	
7	Reverse	Reverse limit switch	Reverse limit switch	
8	Forward	Forward limit switch	Motor Z signal	
9	Reverse	Reverse limit switch	Motor Z signal	

H05-32	Parameter Name	Low speed of homing			Property	During running	Control Mode	P
	Setting Range	0 to 3000	Unit	RPM	Effective Time	Immediate	Default	100
<p>It sets motor speed at searching the deceleration point signal when H05-30 = 1/3/4.</p> <p>It sets maximum motor speed when H05-30 = 2/5.</p> <p>Too small setting of speed will cause too long time on searching home switch signal. In this case, Er.601 will occur.</p>								
H05-33	Parameter Name	High speed of homing			Property	During running	Control Mode	P
	Setting Range	0 to 1000	Unit	RPM	Effective Time	Immediate	Default	10
<p>It sets motor speed at searching the home signal when H05-30 = 1/3/4.</p> <p>If the motor has been close to home switch, it will immediately search the home at low speed set in H05-33 once the homing function is enabled.</p> <p>H05-33 should be set as low as you can to avoid mechanical shock at stop.</p>								
H05-34	Parameter Name	Acceleration/Deceleration time of homing			Property	At stop	Control Mode	P
	Setting Range	0 to 1000	Unit	ms	Effective Time	Immediate	Default	1000
<p>It sets the time for the motor to accelerate from 0 to 1000 RPM or decelerate from 1000 RPM to 0 when H05-30 = 1/2/3/4/5.</p> <p>Thus actual motor acceleration time t during homing is:</p> $t = \frac{H05-32}{1000} \times (H05-34)$								
H05-35	Parameter Name	Duration limit of homing			Property	At stop	Control Mode	P
	Setting Range	0 to 65535	Unit	ms	Effective Time	Immediate	Default	10000
<p>It sets maximum time for searching the home.</p> <p>If the setting of H05-35 is too small or the home is not found within the time set in H05-35, Er.601 will occur.</p>								
H05-36	Parameter Name	Mechanical home offset			Property	At stop	Control Mode	P
	Setting Range	-1073741824 to 1073741824	Unit	Reference unit	Effective Time	Immediate	Default	0
<p>It sets motor absolute position value (H0B-07) after homing.</p> <p>It sets the position relationship of mechanical home reference point and mechanical zero according to the setting of H05-40.</p> <p>It sets the displacement from target position from mechanical home reference point when electrical homing attaining is enabled.</p>								

H05-38	Parameter Name	Servo pulse output source			Property	At stop	Control Mode	P
	Setting Range	0 to 2	Unit	-	Effective Time	Power-on again	Default	0

It sets the output source of the pulse output terminal.

Frequency-division output function cannot be used in full closed-loop control. In this case, the frequency-division output terminal is used for input of external grating scale signal.

Value	Meaning	Description
0	Encoder frequency-division output	The encoder feedback signal is output after being divided based on the setting of H05-17 during motor rotation. Encoder frequency-division output mode is recommended when host computer is used for closed-loop feedback.
1	Pulse synchronous output	Only when H05-00 = 0, the input pulse is synchronously output. When pulses of multi-axis servo is synchronously tracked, pulse synchronous output is suggested.
2	Frequency-division or synchronous output inhibited	The pulse output terminal has no output. In this case, the frequency-division output terminal is used for input of external grating scale signal.

The pulse output terminals are as follows:

Signal	Output Mode	Output Terminal	Max. Pulse Frequency
Phase A signal	Differential output	PAO+, PAO-	2 Mpps
Phase B signal	Differential output	PBO+, PBO-	2 Mpps
Phase Z signal	Differential output	PZO+, PZO-	2 Mpps
	Open-collector output	PZ-OUT, GND	100 kpps

Signal width of phase A/B pulse is determined by motor speed. Signal width of phase Z pulse is half of that of phase A/B pulse.

Output polarity of phase Z signal is determined by the setting of H05-41.

H05-39	Parameter Name	Electronic gear ratio switchover condition			Property	At stop	Control Mode	P
	Setting Range	0 to 1	Unit	-	Effective Time	Immediate	Default	0

It sets the electronic gear ratio switchover condition.

Value	Meaning	Description
0	Switchover if position reference (reference unit) = 0 and the duration reaches 2.5 ms	Set a DI terminal for FunIN.24: GEAR_SEL (Electronic gear ratio selection).
1	Real-time switchover	

It is valid when H05-02 (pulses per one motor revolution) = 0.

H05-40	Parameter Name	Mechanical home offset and action after reaching limit switch			Property	At stop	Control Mode	P
	Setting Range	0 to 3	Unit	-	Effective Time	Immediate	Default	0

It sets the offset of mechanical home reference point and mechanical zero and action after reaching limit switch during the homing operation.

Value	Mechanical Home Offset and Action After Reaching Limit Switch	Description	
		Mechanical Home Reference Point	Action After Reaching Limit Switch
0	H05-36 as coordinate for homing, trigger homing and find home reversely after reaching limit switch	Mechanical zero different from mechanical home reference point. After home attaining is completed, the motor stops at mechanical home reference point and the home coordinate is forced to H05-36.	After the homing enable signal is sent again, the servo drive performs homing reversely.
1	H05-36 as relative offset for homing, trigger homing and find home reversely after reaching limit switch	Mechanical zero same as mechanical home reference point. After positioning mechanical home reference point, the motor continues to move according to the setting of H0-36 and then stops.	After the homing enable signal is sent again, the servo drive performs homing reversely.
2	H05-36 as coordinate for homing, automatically find zero reversely after reaching limit switch	Mechanical zero different from mechanical home reference point. After home attaining is completed, the motor stops at mechanical home and the home coordinate is forced to H05-36.	The servo drive automatically continues to perform homing reversely.
3	H05-36 as relative offset for homing, automatically find zero reversely after reaching limit switch	Mechanical zero same as mechanical home reference point. After positioning mechanical home reference point, the motor continues to move according to the setting of H0-36 and then stops.	The servo drive automatically continues to perform homing reversely.

After the homing operation (including home attaining and electrical home attaining) is completed, the absolute motor position (H0B-07) is consistent with H05-36.

Home attaining completed signal (FunOUT.16: HomeAttain) or electrical home attaining signal (FunOUT.17: ElecHomeAttain) is output only after H0B-07 = H05-36 and is irrelevant to status of the S-ON signal.

For home triggering signal, see the homing function in Chapter 5.

H05-41	Parameter Name	Output polarity of Z pulse			Property	At stop	Control Mode	P
	Setting Range	0 to 1	Unit	-	Effective Time	Power-on again	Default	1

It sets the output level when phase Z is valid at pulse output.

H02-03 (output pulse phase)	H05-41 (output polarity of Z pulse)	Pulse Output Diagram for Forward RUN	Pulse Output Diagram for Reverse RUN
0	0	<p>Phase A advancing phase B by 90°</p>	<p>Phase B advancing phase A by 90°</p>
	1	<p>Phase A advancing phase B by 90°</p>	<p>Phase B advancing phase A by 90°</p>
1	0	<p>Phase B advancing phase A by 90°</p>	<p>Phase A advancing phase B by 90°</p>
	1	<p>Phase B advancing phase A by 90°</p>	<p>Phase A advancing phase B by 90°</p>

The output accuracy of signal Z frequency-division has higher requirement on applications. The valid edge for signal Z output is as follows:

Value	Output Polarity of Z pulse
0	Positive (high level when pulse Z is valid)
1	Negative (low level when pulse Z is valid)

H05-41 = 0: The valid edge is falling edge.

H05-41 = 1: The valid edge is rising edge.

H05-46	Parameter Name	Position offset in absolute position linear mode (low 32 bits)			Property	At stop	Control Mode	PST
	Setting Range	-2147483648 to 2147483647	Unit	1 encoder unit	Effective Time	Power-on again	Default	0

H05-48	Parameter Name	Position offset in absolute position linear mode (high 32 bits)			Property	At stop	Control Mode	PST
	Setting Range	-2147483648 to 2147483647	Unit	1 encoder unit	Effective Time	Power-on again	Default	0
When H02-01 = 1 (absolute position linear mode), position offset in absolute position linear mode equals difference of current encoder absolute position and mechanical position (encoder unit).								
H05-50	Parameter Name	Mechanical gear ratio in absolute position rotating mode (numerator)			Property	At stop	Control Mode	PST
	Setting Range	1 to 65535	Unit	1	Effective Time	Power-on again	Default	65535
H05-51	Parameter Name	Mechanical gear ratio in absolute position rotating mode (denominator)			Property	At stop	Control Mode	PST
	Setting Range	1 to 65535	Unit	1	Effective Time	Power-on again	Default	1
It is transmission ration of rotating load of the mechanical structure to the motor when H02-01 = 2 (Absolute position rotating mode).								
H05-52	Parameter Name	Pulses within one revolution of load in absolute position rotating mode (low 32 bits)			Property	At stop	Control Mode	PST
	Setting Range	0 to 4294967295	Unit	1 encoder unit	Effective Time	Power-on again	Default	0
H05-54	Parameter Name	Pulses within one revolution of load in absolute position rotating mode (high 32 bits)			Property	At stop	Control Mode	PST
	Setting Range	0 to 127	Unit	1 encoder unit	Effective Time	Power-on again	Default	0
It indicates pulses per revolution of load when H02-01 = 2 (Absolute position rotating mode).								
H05-60	Parameter Name	Positioning completed holding time			Property	During running	Control Mode	P
	Setting Range	1 to 30000	Unit	ms	Effective Time	Immediate	Default	1
It sets the valid time of the positioning completed signal (COIN) signal when H05-20 = 3. During the time, the positioning completed signal (COIN) signal becomes invalid if the position reference is not 0.								

Group H06: Speed Control Parameters

H06-00	Parameter Name	Main speed reference A source			Property	At stop	Control Mode	S
	Setting Range	0 to 2	Unit	-	Effective Time	Immediate	Default	0

It sets the source of main speed reference A.

Value	Meaning	Description
0	Digital setting	Main speed reference A is set by H06-03.
1	A11	Main speed reference A is input from AI1. Correspondence between voltage input from AI1 and speed reference is determined by H03-50, H03-51, H03-53, H03-54 and H03-80. For details, refer to section 5.3.1.
2	AI2	Main speed reference A is input from AI2. Correspondence between voltage input from AI1 and speed reference is determined by H03-55, H03-56, H03-58, H03-59 and H03-80. For details, refer to section 5.3.1.

Note:

Digital setting is internal speed reference. AI1 and AI2 are external speed reference sources. For details on AI1 and AI2, refer to chapter 3.

H06-01	Parameter Name	Auxiliary speed reference B source			Property	At stop	Control Mode	S
	Setting Range	0 to 5	Unit	-	Effective Time	Immediate	Default	1

It sets the source of auxiliary speed reference B.

Value	Meaning	Description
0	Digital setting	Auxiliary speed reference B is set by H06-03.
1	AI1	Auxiliary speed reference B is input from AI1. Correspondence between voltage input from AI1 and speed reference is determined by H03-50, H03-51, H03-53, H03-54 and H03-80. For details, refer to section 5.3.1.
2	AI2	Auxiliary speed reference B is input from AI2. Correspondence between voltage input from AI1 and speed reference is determined by H03-55, H03-56, H03-58, H03-59 and H03-80. For details, refer to section 5.3.1.
3	-	Invalid
4	-	Invalid
5	Multi-speed reference	For details on multi-speed, refer to parameters in group H12.

Note:

Digital setting and multi-speed are internal speed references. AI1 and AI2 are external speed reference sources. For details on AI1 and AI2, refer to chapter 3.

H06-02	Parameter Name	Speed reference source selection			Property	At stop	Control Mode	S																									
	Setting Range	0 to 4	Unit	-	Effective Time	Immediate	Default	0																									
It selects speed reference source.																																	
<table border="1"> <thead> <tr> <th>Value</th> <th>Meaning</th> <th>Description</th> </tr> </thead> <tbody> <tr> <td>0</td> <td>Main speed reference A source</td> <td>The speed reference is set in H06-00.</td> </tr> <tr> <td>1</td> <td>Auxiliary speed reference B source</td> <td>The speed reference is set in H06-01.</td> </tr> <tr> <td>2</td> <td>A + B</td> <td>The speed reference is set in both H06-00 and H06-01.</td> </tr> <tr> <td rowspan="3">3</td> <td rowspan="3">A/B switchover</td> <td>A/B switchover is implemented through DI function FunIN.4: Cmd_SEL.</td> </tr> <tr> <td> <table border="1"> <thead> <tr> <th>FunIN.4 (Cmd_SEL) State</th> <th>Speed Reference Selection</th> </tr> </thead> <tbody> <tr> <td>Invalid</td> <td>Main speed reference A source</td> </tr> <tr> <td>Valid</td> <td>Auxiliary speed reference B source</td> </tr> </tbody> </table> </td> </tr> <tr> <td>4</td> <td>Communication setting</td> <td>The speed reference is set in H31-09 via communication and the accuracy is 0.001 RPM.</td> </tr> </tbody> </table>									Value	Meaning	Description	0	Main speed reference A source	The speed reference is set in H06-00.	1	Auxiliary speed reference B source	The speed reference is set in H06-01.	2	A + B	The speed reference is set in both H06-00 and H06-01.	3	A/B switchover	A/B switchover is implemented through DI function FunIN.4: Cmd_SEL.	<table border="1"> <thead> <tr> <th>FunIN.4 (Cmd_SEL) State</th> <th>Speed Reference Selection</th> </tr> </thead> <tbody> <tr> <td>Invalid</td> <td>Main speed reference A source</td> </tr> <tr> <td>Valid</td> <td>Auxiliary speed reference B source</td> </tr> </tbody> </table>	FunIN.4 (Cmd_SEL) State	Speed Reference Selection	Invalid	Main speed reference A source	Valid	Auxiliary speed reference B source	4	Communication setting	The speed reference is set in H31-09 via communication and the accuracy is 0.001 RPM.
Value	Meaning	Description																															
0	Main speed reference A source	The speed reference is set in H06-00.																															
1	Auxiliary speed reference B source	The speed reference is set in H06-01.																															
2	A + B	The speed reference is set in both H06-00 and H06-01.																															
3	A/B switchover	A/B switchover is implemented through DI function FunIN.4: Cmd_SEL.																															
		<table border="1"> <thead> <tr> <th>FunIN.4 (Cmd_SEL) State</th> <th>Speed Reference Selection</th> </tr> </thead> <tbody> <tr> <td>Invalid</td> <td>Main speed reference A source</td> </tr> <tr> <td>Valid</td> <td>Auxiliary speed reference B source</td> </tr> </tbody> </table>	FunIN.4 (Cmd_SEL) State	Speed Reference Selection	Invalid	Main speed reference A source	Valid	Auxiliary speed reference B source																									
		FunIN.4 (Cmd_SEL) State	Speed Reference Selection																														
Invalid	Main speed reference A source																																
Valid	Auxiliary speed reference B source																																
4	Communication setting	The speed reference is set in H31-09 via communication and the accuracy is 0.001 RPM.																															

H06-03	Parameter Name	Keypad setting value of speed reference			Property	During running	Control Mode	S
	Setting Range	-6000 to 6000	Unit	RPM	Effective Time	Immediate	Default	200
It sets the speed reference when H06-00/H06-01 = 0.								

H06-04	Parameter Name	Jog speed setting value			Property	During running	Control Mode	PST
	Setting Range	0 to 6000	Unit	RPM	Effective Time	Immediate	Default	100
It sets jog speed reference when DI jog function is used. DI jog function can be enabled in normal drive running status. It is unrelated to control mode.								

H06-05	Parameter Name	Acceleration ramp time constant of speed reference			Property	During running	Control Mode	S
	Setting Range	0 to 65535	Unit	ms	Effective Time	Immediate	Default	0

H06-06	Parameter Name	Deceleration ramp time constant of speed reference			Property	During running	Control Mode	S
	Setting Range	0 to 65535	Unit	ms	Effective Time	Immediate	Default	0

It sets the deceleration ramp time constant of speed reference only. The acceleration/deceleration ramp time constant is determined by parameters in group H12.

H06-05: time for speed reference to accelerate from 0 to 1000 RPM
H06-06: time for speed reference to decelerate from 1000 RPM to 0

Thus, actual acceleration/deceleration time calculation formulas are as follows:

$$\text{Actual acceleration time } t_1 = \frac{\text{Speed reference}}{1000} \times \text{acceleration ramp time of speed reference}$$

$$\text{Actual deceleration time } t_2 = \frac{\text{Speed reference}}{1000} \times \text{Deceleration ramp time of speed reference}$$

H06-07	Parameter Name	Maximum speed limit			Property	During running	Control Mode	S
	Setting Range	0 to 6000	Unit	RPM	Effective Time	Immediate	Default	6000

H06-08	Parameter Name	Positive speed limit			Property	During running	Control Mode	S
	Setting Range	0 to 6000	Unit	RPM	Effective Time	Immediate	Default	6000

H06-09	Parameter Name	Negative speed limit			Property	During running	Control Mode	S
	Setting Range	0 to 6000	Unit	RPM	Effective Time	Immediate	Default	6000

It sets speed reference limit in speed control. The speed reference limit sources are as follows:

H06-07: It sets both the positive and negative speed limits of speed reference. If speed reference exceeds the setting of H06-07, the speed reference will be limited as this value.

H06-08: It sets the positive speed limit. If positive speed reference exceeds the setting of H06-08, the reference will be limited as this value.

H06-09: It sets the negative speed limit. If reverse speed reference exceeds the setting of H06-09, the reference will be limited as this value.

Max. motor speed (default limit) is determined by motor model.

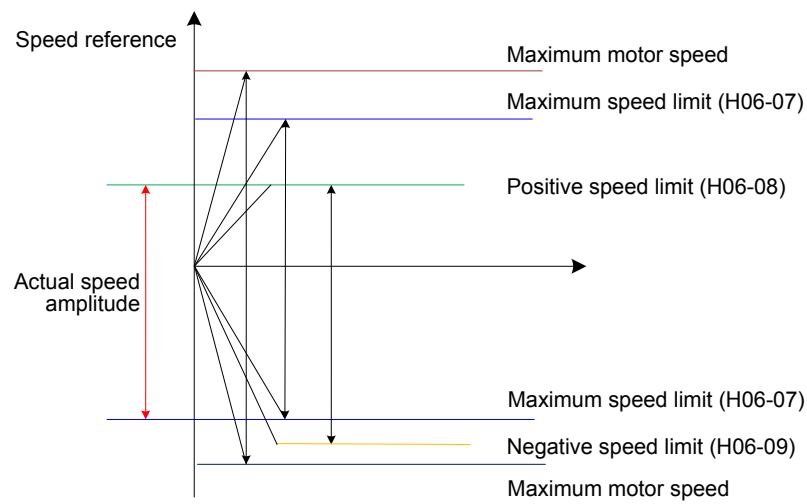

Thus, motor speed in positive/negative direction is limited as below:

$$|\text{Positive speed limit}| \leq \min \{ \text{maximum motor speed, H06-07, H06-08} \}$$

$$|\text{Negative speed limit}| \leq \min \{ \text{motor rotational speed, H06-07, H06-09} \}$$

H06-11	Parameter Name	Torque feedforward control selection			Property	During running	Control Mode	PS
	Setting Range	0 to 1	Unit	-	Effective Time	Immediate	Default	1

It sets whether to enable the internal torque feedforward function in non-torque control.

The torque feedforward function can improve torque reference response speed and reduce position deviation during fixed acceleration/deceleration.

Value	Meaning	Description
0	Disabled	-
1	Enabled	The torque feedforward signal source is speed reference. From output of position controller in position control From user speed reference in speed control

Parameters of torque feedforward includes H08-20 (torque feedforward filter time constant) and H08-21 (torque feedforward gain). For details, refer to section 6.4.4.

In non-torque control, the control block diagram of torque feedforward is as follows:

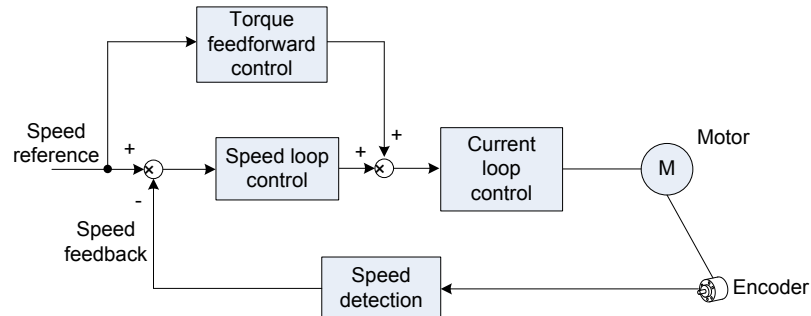

H06-15	Parameter Name	Speed threshold for zero speed clamp			Property	During running	Control Mode	S
	Setting Range	0 to 6000	Unit	RPM	Effective Time	Immediate	Default	10

Zero speed clamp: In speed control, if DI function FunIN.12 (ZCLAMP) function is enabled, and the speed reference amplitude is smaller than or equal to the value of H06-15, the servo motor enters the zero speed clamp state. At this moment, position loop is built inside the servo drive and speed reference is invalid. The servo motor is clamped within ± 1 pulse of the position at which zero speed clamp becomes valid. Even if it rotates due to external force, it will return to the zero position and be clamped.

When the speed reference amplitude is larger than the value of H06-15, the servo motor exits the zero speed clamp state. At this moment, the servo motor continues to run according to the input speed reference.

If DI function FunIN.12 (ZCLAMP) is disabled, the zero speed clamp function is invalid.

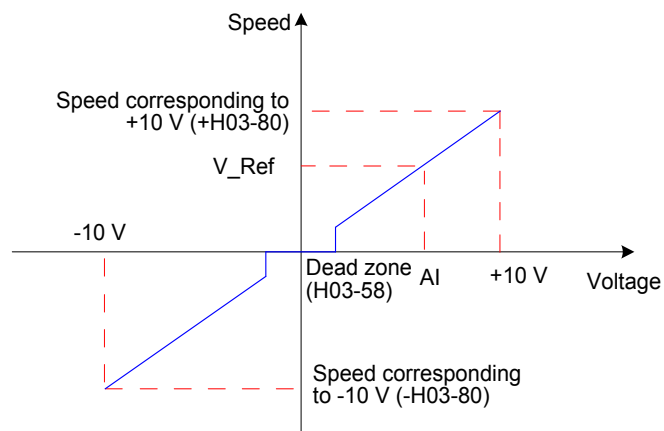

H06-16	Parameter Name	Speed threshold of motor rotation signal			Property	During running	Control Mode	S
	Setting Range	0 to 1000	Unit	RPM	Effective Time	Immediate	Default	20

When absolute value of the actual motor speed after filter reaches the setting of H06-16, the motor can be considered to rotate. At this moment, the servo drive outputs the motor rotation signal (FunOUT.2: TGON) to confirm that motor has rotated.

When the absolute value of the actual motor speed after filter is smaller than the setting of H06-16, the motor is considered not to rotate.

Judgment on the motor rotation signal (FunOUT.2, TGON) is not influenced by the servo drive status and control mode.

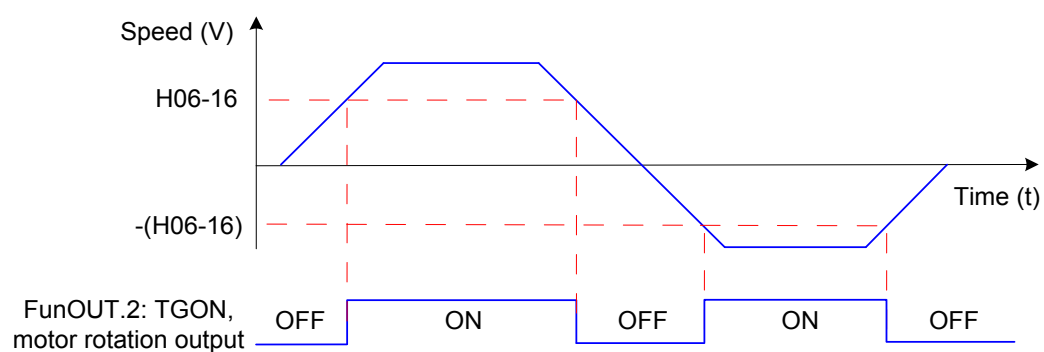

Note:

In the preceding figure, ON indicates that the motor rotation DO signal is active. OFF indicates that the motor rotation DO signal is inactive.

The filter time constant of motor speed can be set in H0A-27 (speed DO filter time constant).

H06-17	Parameter Name	Threshold of speed consistent signal			Property	During running	Control Mode	S
	Setting Range	0 to 100	Unit	RPM	Effective Time	Immediate	Default	10

In speed control, when the absolute value of the difference between the motor speed after filter and the speed reference satisfies the setting of H06-17, the actual motor speed is considered to reach the speed reference. At this moment, the servo drive outputs the speed consistent signal (FunOUT.4: V-CMP).

When the absolute value of the difference between the motor speed after filter and the speed reference exceeds the setting of H06-17, the speed consistent signal is inactive.

If the servo drive is not in running status or in speed control, the speed consistent signal (FunOUT.4: V-CMP) is always inactive.

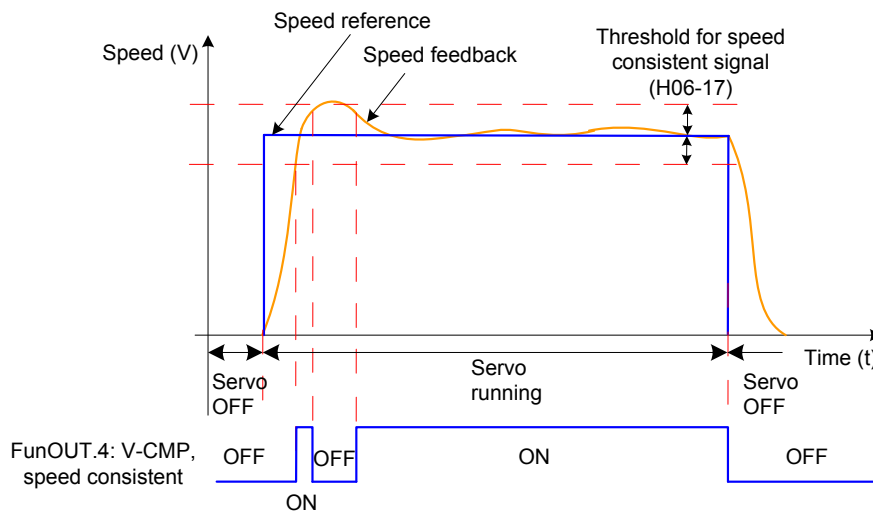

Note:

In the preceding figure, ON indicates that the speed consistent DO signal is valid. OFF indicates that the speed consistent DO signal is invalid.

The filter time constant of motor speed can be set in H0A-27 (Filter time constant of speed DO).

H06-18	Parameter Name	Threshold of speed reached signal			Property	During running	Control Mode	S
	Setting Range	10 to 6000	Unit	RPM	Effective Time	Immediate	Default	1000

When the absolute value of the motor speed after filter exceeds the setting of H06-18, the motor speed is considered to reach the desired value. At this moment, the servo drive outputs the speed reached signal (FunOUT.19: V-Arr).

When the absolute value of the motor speed after filter is smaller than or equal to the setting of H06-18, the speed reached signal is inactive.

Judgment on the speed reached signal (FunOUT.19: V-Arr) is not influenced by the servo drive status and control mode.

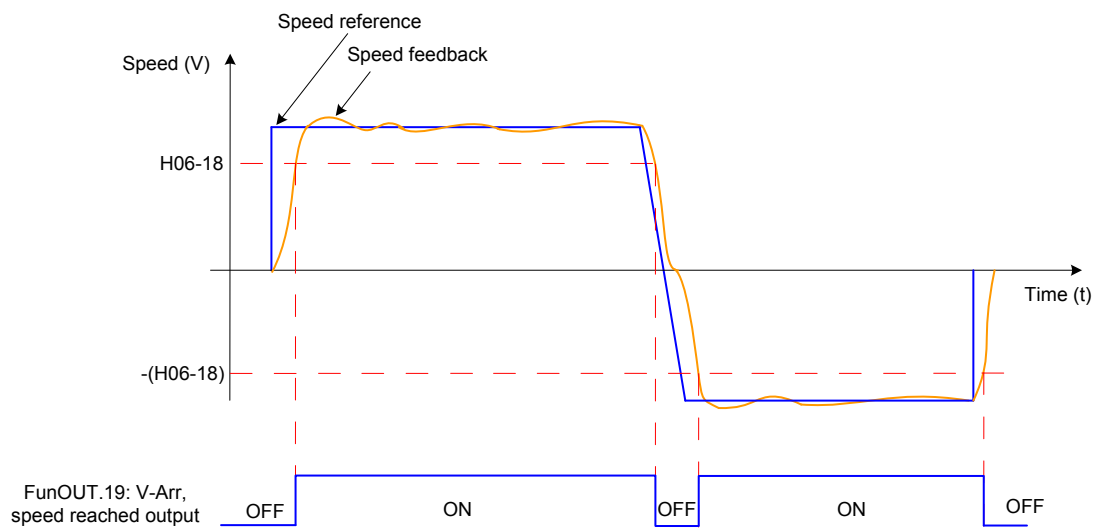

Note:

In the preceding figure, ON indicates that the speed reached DO signal is valid. OFF indicates that the speed reached DO signal is invalid.

The filter time constant of motor speed can be set in H0A-27 (Filter time constant of speed DO).

H06-19	Parameter Name	Threshold of zero speed output signal			Property	During running	Control Mode	S
	Setting Range	1 to 6000	Unit	RPM	Effective Time	Immediate	Default	10

When the absolute value of the motor speed after filter is smaller than the setting of H06-19, the motor speed is considered to be close to 0. At this moment, the servo drive outputs the zero speed signal (FunOUT.3: V-Zero).

When the absolute value of the motor speed after filter is smaller than or equal to the setting of H06-19, the zero speed signal is inactive.

Judgment on the zero speed signal (FunOUT.3: V-Zero) is not influenced by the servo drive status and control mode.

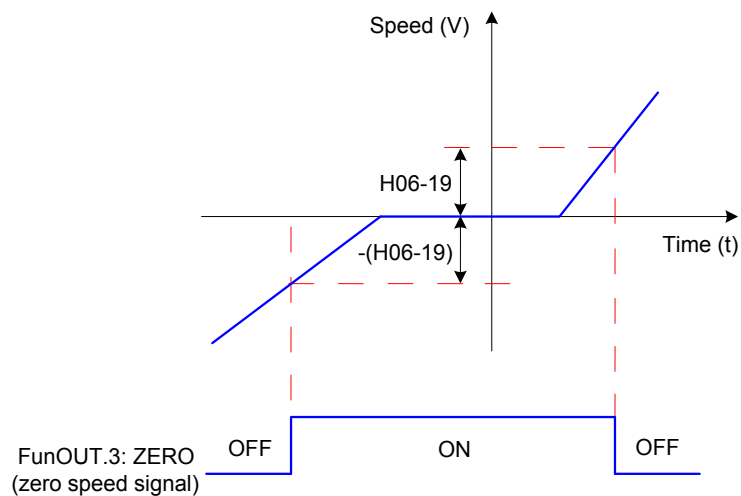

Note:

In the preceding figure, ON indicates that the zero-speed DO signal is valid. OFF indicates that the zero-speed DO signal is invalid.

The filter time constant of motor speed can be set in H0A-27 (Filter time constant of speed DO).

Group H07: Torque Control Parameters

H07-00	Parameter Name	Main torque reference A source			Property	At stop	Control Mode	T
	Setting Range	0 to 2	Unit	-	Effective Time	Immediate	Default	0

It sets the main torque reference A source.

Value	Meaning	Description
0	Digital setting	Main torque reference A is set by H07-03.
1	AI1	Torque reference A is input from AI1. Correspondence between voltage input from AI1 and speed reference is determined by H03-50, H03-51, H03-53, H03-54 and H03-81. For details, refer to section 5.4.1.
2	AI2	Torque reference A is input from AI2. Correspondence between voltage input from AI2 and speed reference is determined by H03-55, H03-56, H03-58, H03-59 and H03-81. For details, refer to section 5.4.1.

Note:

Digital setting is internal torque reference. AI1 and AI2 are external torque reference sources. For details on AI1 and AI2, refer to chapter 3.

H07-01	Parameter Name	Auxiliary torque reference B source			Property	At stop	Control Mode	T
	Setting Range	0 to 2	Unit	-	Effective Time	Immediate	Default	1

It sets the main torque reference B source.

Value	Meaning	Description
0	Digital setting	Auxiliary torque reference B is set by H07-03.
1	AI1	Torque reference B is input from AI1. Correspondence between voltage input from AI1 and speed reference is determined by H03-50, H03-51, H03-53, H03-54 and H03-81. For details, refer to section 5.4.1.
2	AI2	Torque reference B is input from AI2. Correspondence between voltage input from AI1 and speed reference is determined by H03-55, H03-56, H03-58, H03-59 and H03-81. For details, refer to section 5.4.1.

Note:

Digital setting is internal torque reference. AI1 and AI2 are external torque reference sources. For details on AI1 and AI2, refer to chapter 3.

H07-02	Parameter Name	Torque reference source			Property	At stop	Control Mode	T
	Setting Range	0 to 3	Unit	-	Effective Time	Immediate	Default	0

It selects torque reference source.

Value	Meaning	Description						
0	Main torque reference A source	The torque reference is set in H07-00.						
1	Auxiliary torque reference B source	The torque reference is set in H07-01.						
2	A + B	The torque reference is set in both H07-00 and H07-01.						
3	A/B switchover	<p>A/B switchover is implemented through DI function FunIN.4: Cmd_SEL.</p> <table border="1"> <thead> <tr> <th>FunIN.4 : Cmd_Sel Status</th> <th>Torque Reference Source Selection</th> </tr> </thead> <tbody> <tr> <td>Invalid</td> <td>Main torque reference A source</td> </tr> <tr> <td>Valid</td> <td>Auxiliary torque reference B source</td> </tr> </tbody> </table>	FunIN.4 : Cmd_Sel Status	Torque Reference Source Selection	Invalid	Main torque reference A source	Valid	Auxiliary torque reference B source
FunIN.4 : Cmd_Sel Status	Torque Reference Source Selection							
Invalid	Main torque reference A source							
Valid	Auxiliary torque reference B source							
4	Communication setting	The torque reference is set in H31-11 via special communication.						

H07-03	Parameter Name	Keypad setting value of torque reference			Property	During running	Control Mode	T
	Setting Range	-300.0 to 300.0	Unit	%	Effective Time	Immediate	Default	0

It sets the torque reference when H07-00/H07-01 = 0.
100.0% corresponds to one time of rated motor torque.

H07-05	Parameter Name	Time constant of torque reference filter			Property	During running	Control Mode	PST
	Setting Range	0 to 30.00	Unit	ms	Effective Time	Immediate	Default	0.79

H07-06	Parameter Name	2nd time constant of torque reference filter			Property	During running	Control Mode	PST
	Setting Range	0 to 30.00	Unit	ms	Effective Time	Immediate	Default	0.79

It sets the time constant of torque reference filter.

Low-pass filter of torque reference helps to make torque reference more smooth and reduce vibration.

Too large setting of this parameter will slow response. Observe the response when setting this parameter.

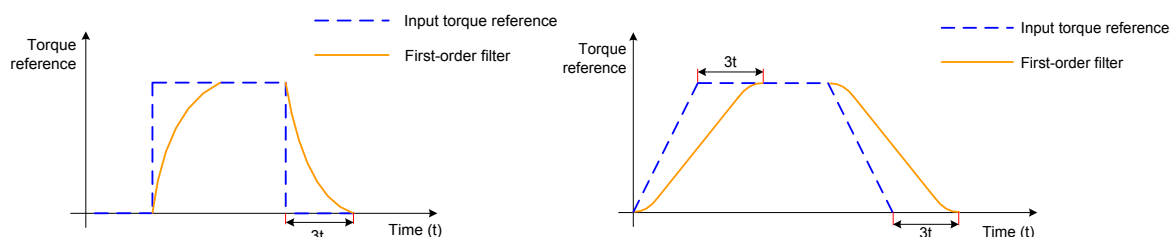

Note:

The servo drive provides two torque reference low-pass filters. Filter 1 is used by default.

In position or speed control, gain switchover can be used. Once certain conditions are satisfied, the drive switches over to filter 2. For details on gain switchover, refer to section 6.4.2.

H07-07	Parameter Name	Torque limit source			Property	At stop	Control Mode	PST
	Setting Range	0 to 4	Unit	-	Effective Time	Immediate	Default	0

It sets the source of torque limit. For details, refer to chapter 5.

Value	Meaning
0	Internal positive/negative torque limit
1	External positive/negative torque limit (via P-CL, N-CL)
2	T-LMT as external torque limit
3	Minimum of external positive/negative torque and external T-LMT as torque limit (via P-CL, N-CL)
4	Switchover between internal positive/negative torque limit and T-LMT torque limit (via P-CL, N-CL)

Note:

Torque limit is valid for position control, speed control, torque control and hybrid control.

H07-08	Parameter Name	T-LMT selection			Property	At stop	Control Mode	PST
	Setting Range	1, 2	Unit	-	Effective Time	Immediate	Default	2

It selects the analog input channel of torque limit when H07-07 = 2/3/4 (external torque limit enabled).

Value	Meaning	Description
1	AI1	AI1 used as external torque limit input channel
2	AI2	AI2 used as external torque limit input channel

For related settings of AI, refer to section 5.4.1. For final torque limit, refer to chapter 5.

H07-09	Parameter Name	Internal positive torque limit			Property	During running	Control Mode	PST
	Setting Range	0.0 to 300.0	Unit	%	Effective Time	Immediate	Default	300.0

H07-10	Parameter Name	Internal negative torque limit			Property	During running	Control Mode	PST
	Setting Range	0.0 to 300.0	Unit	%	Effective Time	Immediate	Default	300.0

It sets the internal positive/negative torque limit value when H07-07 = 0 or 4. 100.0% corresponds to one time of rated motor torque.

Note:

1. If the setting of H07-09 and H07-10 is too small, insufficient torque may occur during acceleration/ deceleration of servo motor.
2. If the setting of H07-09 and H07-10 exceeds maximum torque of the servo drive and servo motor, actual torque will be limited within the maximum torque.
3. For final torque limit, refer to chapter 5.

H07-11	Parameter Name	External positive torque limit			Property	During running	Control Mode	PST
	Setting Range	0.0 to 300.0	Unit	%	Effective Time	Immediate	Default	300.0

H07-12	Parameter Name	External negative torque limit			Property	During running	Control Mode	PST
	Setting Range	0.0 to 300.0	Unit	%	Effective Time	Immediate	Default	300.0

It sets the external fopositive/negative torque limit value when H07-07 = 1 or 3. 100.0% corresponds to one time of rated motor torque. For final torque limit, refer to chapter 5.

H07-17	Parameter Name	Speed limit source			Property	During running	Control Mode	T
	Setting Range	0 to 2	Unit	-	Effective Time	Immediate	Default	0

It sets the source of speed limit in torque control.

After speed limit is set, motor speed will be limited within the setting value. After reaching the limit value, servo motor will run at this value constantly.

Value	Meaning	Description
0	Internal speed limit	Speed limit is set in H07-19 and H07-20.
1	V-LMT as external speed limit	Speed limit value in different directions is determined by minimum between speed corresponding to voltage input from AI and H07-19 (Positive speed limit)/H07-20 (Negative speed limit).
2	Speed limit selected via DI	FunIN.36 invalid: H07-19 used as positive/negative speed limit FunIN.36 valid: H07-20 used as positive/negative speed limit

Note:

For speed limit in torque control, refer to chapter 5.

H07-18	Parameter Name	V-LMT selection			Property	During running	Control Mode	T
	Setting Range	1 to 2	Unit	-	Effective Time	Immediate	Default	1

It selects the analog input channel when external analog (V-LMT) is used for speed limit in torque control.

Value	Meaning	Description
1	AI1	AI1 used as external speed limit input channel
2	AI2	AI2 used as external speed limit input channel

H07-19	Parameter Name	Positive speed limit/1st speed limit in torque control			Property	During running	Control Mode	T
	Setting Range	0 to 6000	Unit	RPM	Effective Time	Immediate	Default	3000

H07-20	Parameter Name	Negative speed limit/2nd speed limit in torque control			Property	During running	Control Mode	T
	Setting Range	0 to 6000	Unit	RPM	Effective Time	Immediate	Default	3000

It sets speed limit in torque control. For details, refer to chapter 5.

H07-21	Parameter Name	Base value for torque reached			Property	During running	Control Mode	PST
	Setting Range	0.0 to 300.0	Unit	%	Effective Time	Immediate	Default	0.0

H07-22	Parameter Name	Threshold of torque reached valid			Property	During running	Control Mode	PST
	Setting Range	0.0 to 300.0	Unit	%	Effective Time	Immediate	Default	20.0

H07-23	Parameter Name	Threshold of torque reached invalid			Property	During running	Control Mode	PST
	Setting Range	0.0 to 300.0	Unit	%	Effective Time	Immediate	Default	10.0

The torque reached function (FunOUT.18: ToqReach) is used to judge whether torque reference reaches the range of torque reached valid value. When reaching this range, the servo drive outputs corresponding DO signal to the host computer.

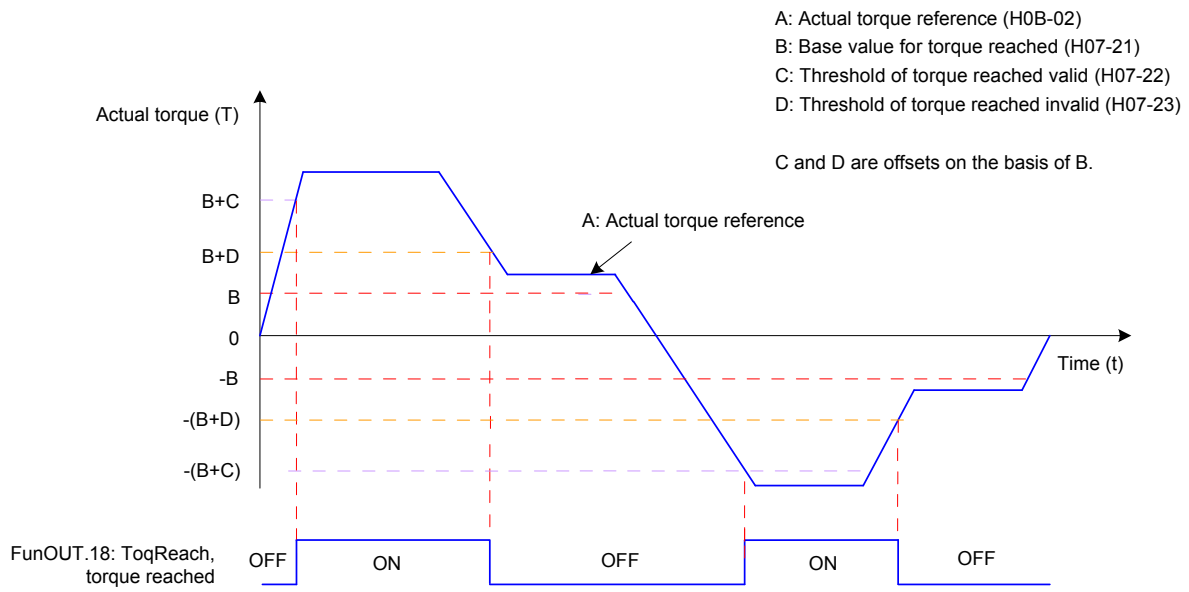

The torque reached signal becomes active when the actual torque reference meets the condition:

$$|A| \geq B + C$$

Otherwise, the torque reached signal remains inactive.

The torque reached signal becomes inactive when the actual torque reference meets the condition:

$$|A| < B + D$$

Otherwise, the torque reached signal remains active.

H07-40	Parameter Name	Speed limit window in the torque control mode			Property	During running	Control Mode	T
	Setting Range	0.5 to 30.0	Unit	ms	Effective Time	Immediate	Default	1.0

When absolute value of motor speed exceeds speed limit value (for speed limit setting in torque control, refer to section 5.4.4) in torque control and this status lasts for the time set in this parameter, motor speed is considered to be limited. At this moment, servo drive outputs FunOUT.8: V-LT (Speed limit). If either of the two conditions is not satisfied, the speed limit signal is invalid.

The speed limit (FunOUT.8: V-LT) signal is judged only in torque control and S-ON status.

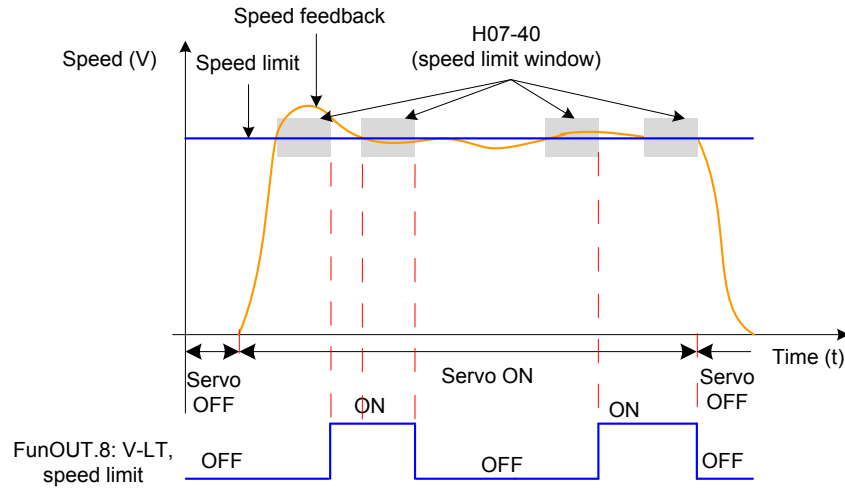

Note:

In the preceding figure, ON indicates that the speed limit DO signal is valid. OFF indicates that the speed limit DO signal is invalid.

Group H08: Gain Parameters

H08-00	Parameter Name	Speed loop gain			Property	During running	Control Mode	PS
	Setting Range	0.1 to 2000.0	Unit	Hz	Effective Time	Immediate	Default	25.0

It sets proportional gain of speed loop.

This parameter determines response of speed loop. The larger the setting is, the quicker response will be. But too large setting may cause vibration.

If position loop gain need be increased in position control, it is necessary to increase speed loop gain simultaneously.

H08-01	Parameter Name	Time constant of speed loop integration			Property	During running	Control Mode	PS
	Setting Range	0.15 to 512.00	Unit	ms	Effective Time	Immediate	Default	31.83

It sets the time constant of speed loop integration

The smaller the setting is, the better integration effect will be obtained and the deviation value at stop will be close to 0 more quickly.

Note:

When H08-01 = 512.00, the integration function is disabled.

H08-02	Parameter Name	Position loop gain			Property	During running	Control Mode	P
	Setting Range	0.0 to 2000.0	Unit	Hz	Effective Time	Immediate	Default	40.0

It sets proportional gain of position loop.

This parameter determines response of position loop. A large position loop gain can reduce positioning time. But too large setting may cause vibration.

H08-00, H08-01, H08-02 and H07-05 (Time constant of torque reference filter) are called the 1st gain.

H08-03	Parameter Name	2nd gain of speed loop			Property	During running	Control Mode	PS
	Setting Range	0.1 to 2000.0	Unit	Hz	Effective Time	Immediate	Default	40.0

H08-04	Parameter Name	2nd time constant of speed loop integration			Property	During running	Control Mode	PS
	Setting Range	0.15 to 512.00	Unit	ms	Effective Time	Immediate	Default	40.00

H08-05	Parameter Name	2nd gain of position loop			Property	During running	Control Mode	P
	Setting Range	0.0 to 2000.0	Unit	Hz	Effective Time	Immediate	Default	64.0

It sets the 2nd gain of position loop and speed loop. H08-03, H08-04, H08-05 and H07-06 (2nd time constant of torque reference filter) are called the 2nd gain.

For details on gain switchover, refer to section 6.4.2.

H08-08	Parameter Name	2nd gain mode setting			Property	During running	Control Mode	PST
	Setting Range	0. 1	Unit	-	Effective Time	Immediate	Default	1

It sets switchover mode of the 2nd gain.

Value	Meaning
0	1st gain fixed. P/PI of speed control is switched over via DI function FunIN.3: GAIN_SEL. GAIN_SEL invalid: PI control GAIN_SEL valid: P control
1	Gain switchover based on H08-09 The 1st gain (H08-00 to H08-02, H07-05) and the 2nd gain (H08-03 to H08-05, H07-06) is switched over according to the setting of H08-09.

H08-09	Parameter Name	Gain switchover condition			Property	During running	Control Mode	PST
	Setting Range	0 to 10	Unit	-	Effective Time	Immediate	Default	0

It sets the condition for gain switchover.

Value	Meaning	Description
0	Fixed at 1st gain	Always use the 1st gain.
1	Switchover via DI	The gain is switched over by using the GAIN-SEL signal. GAIN-SEL signal invalid: 1st gain (H08-00 to H08-02, H07-05) GAIN-SEL signal valid: 2nd gain (H08-03 to H08-05, H07-06) If the GAIN-SEL signal cannot be allocated to a DI terminal, always use the 1st gain.
2	Torque reference being large	When absolute value of torque reference exceeds (level + hysteresis, %) in the 1st gain, the drive switches over to the 2nd gain. When absolute value of torque reference is smaller than or equal to (level – hysteresis, %) and this status lasts within the delay (H08-10) in the 2nd gain, the drive returns to the 1st gain.
3	Speed reference being large	When absolute value of speed reference exceeds (level + hysteresis, RPM) in the 1st gain, the drive switches over to the 2nd gain. When absolute value of speed reference is smaller than or equal to (level - hysteresis, RPM) and this status lasts within the delay (H08-10) in the 2nd gain, the drive returns to the 1st gain.
4	Speed reference change rate being large	It is valid only in non-speed control. When absolute value of speed reference change rate exceeds (level + hysteresis, 10 RPM/s) in the 1st gain, the drive switches over to the 2nd gain. When absolute value of speed reference change rate is smaller than or equal to (level – hysteresis, 10 RPM/s) and this status lasts within the delay (H08-10) in the 2nd gain, the drive returns to the 1st gain. The drive always uses the 1st gain in speed control.
5	Speed reference high-speed/low-speed thresholds	When absolute value of speed reference exceeds (level – hysteresis, RPM) in the 1st gain, the drive starts to switch over to the 2nd gain and the gain changes gradually. When absolute value of speed reference exceeds (level + hysteresis, RPM), the drive completely switches over to the 2nd gain. When absolute value of speed reference is smaller than (level + hysteresis, RPM) in the 2nd gain, the drive starts to return to the 1st gain and the gain changes gradually. When absolute value of speed reference reaches (level – hysteresis, RPM), the drive completely returns to the 1st gain.

Value	Meaning	Description
6	Position deviation being large	<p>It is valid only in position control and full closed-loop control.</p> <p>When absolute value of position deviation exceeds (level + hysteresis, encoder unit) in the 1st gain, the drive switches over to the 2nd gain.</p> <p>When absolute value of position deviation is smaller than (level - hysteresis, encoder unit) and this status lasts within the delay (H08-10) in the 2nd gain, the drive returns to the 1st gain.</p> <p>The drive always uses the 1st gain if the drive is not in position control or full closed-loop control.</p>
7	Position reference available	<p>It is valid only in position control and full closed-loop control.</p> <p>When position reference is not 0 in the 1st gain, the drive switches over to the 2nd gain.</p> <p>When position reference is 0 and this status lasts within the delay (H08-10) in the 2nd gain, the drive returns to the 1st gain.</p> <p>The drive always uses the 1st gain if the drive is not in position control or full closed-loop control.</p>
8	Positioning completion	<p>It is valid only in position control and full closed-loop control.</p> <p>When positioning is not completed in the 1st gain, the drive switches over to the 2nd gain.</p> <p>When positioning is not completed and this status lasts within the delay (H08-10) in the 2nd gain, the drive returns to the 1st gain.</p> <p>The drive always uses the 1st gain if the drive is not in position control or full closed-loop control.</p>
9	Motor speed being large	<p>It is valid only in position control and full closed-loop control.</p> <p>When absolute value of motor speed exceeds (level + hysteresis, RPM) in the 1st gain, the drive switches over to the 2nd gain.</p> <p>When absolute value of motor speed is smaller than or equal to (level - hysteresis, RPM) and this status lasts within the delay (H08-10) in the 2nd gain, the drive returns to the 1st gain.</p> <p>The drive always uses the 1st gain if the drive is not in position control or full closed-loop control.</p>
10	Position reference available + Motor speed	<p>It is valid only in position control and full closed-loop control.</p> <p>When position reference is not 0 in the 1st gain, the drive switches over to the 2nd gain.</p> <p>When position reference is 0 and this status lasts within the delay (H08-10) in the 2nd gain, the drive still uses the 2nd gain.</p> <p>When position reference is 0 and the delay (H08-10) is reached, if absolute value of motor speed is smaller than (level, RPM), the speed loop integration time constant is fixed at the setting of H08-04 (2nd time constant of speed loop integration), the drive returns to the 1st gain on the other aspects. If absolute value of motor speed does not reach (level - hysteresis, RPM), the speed loop integration time constant returns to the setting of H08-01 (Time constant of speed loop integration).</p> <p>The drive always uses the 1st gain if the drive is not in position control or full closed-loop control.</p>

H08-10	Parameter Name	Gain switchover delay			Property	During running	Control Mode	PST
	Setting Range	0.0 to 1000.0	Unit	ms	Effective Time	Immediate	Default	5.0

It sets the delay when the servo drive returns to the 1st gain from the 2nd gain.

H08-11	Parameter Name	Gain switchover level			Property	During running	Control Mode	PST
	Setting Range	0 to 20000	Unit	Based on switchover condition	Effective Time	Immediate	Default	50

It sets the level for gain switchover.

Switchover is influenced by both level and hysteresis. For details, see description of H08-09. The unit of gain switchover level varies with switchover condition.

H08-12	Parameter Name	Gain switchover hysteresis			Property	During running	Control Mode	PST
	Setting Range	0 to 20000	Unit	Based on switchover condition	Effective Time	Immediate	Default	30

It sets the hysteresis for gain switchover.

Switchover is influenced by both level and hysteresis. For details, see description of H08-09. The unit of gain switchover hysteresis varies with switchover condition.

Note:

Please set $H08-11 \geq H08-12$. If $H08-11 < H08-12$ is set, the servo drive will set $H08-11 = H08-12$.

H08-13	Parameter Name	Position gain switchover time			Property	During running	Control Mode	P
	Setting Range	0.0 to 1000.0	Unit	ms	Effective Time	Immediate	Default	3.0

If H08-05 (2nd position loop gain) is much larger than H08-02 (Position loop gain), set the time of switching over from H08-02 to H08-05.

This parameter can reduce the impact of an increase in position loop gain.

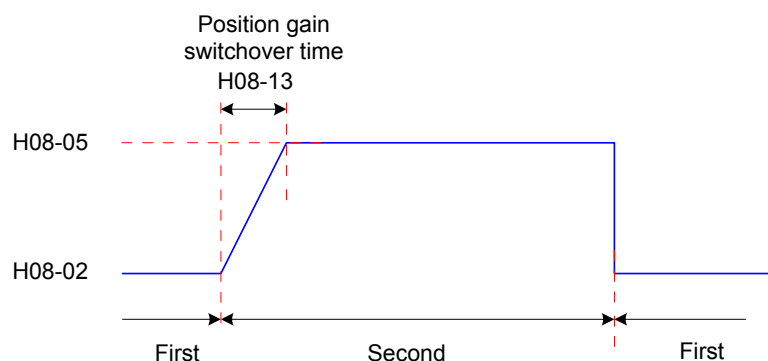

If $H08-05 \leq H08-02$, this parameter is invalid and the servo drive switches over to the 2nd gain immediately.

H08-15	Parameter Name	Load/Rotor inertia ratio			Property	During running	Control Mode	PST
	Setting Range	0.00 to 120.00	Unit	times	Effective Time	Immediate	Default	1.00

It sets the ratio of the load inertia against the rotor (of the motor) inertia.

$$\text{Load inertia ratio} = \frac{\text{Load inertia}}{\text{Rotor inertia}}$$

H08-15 indicates motor without load. H08-15 = 1.00 indicates that moment of inertia of load equals moment of inertia of motor.

The servo drive automatically calculates and updates the value of H08-15 through inertia auto-tuning (offline and online).

When online inertia auto-tuning (H09-03 ≠ 0) is used, the servo drive set this parameter automatically and manual setting is not allowed. After H09-03 = 0 is set, manual setting is allowed.

Note:

If the value of H08-15 equals actual inertia ratio, the value of H08-00/H08-03 (Speed loop gain) can represent maximum follow-up frequency of actual speed loop.

H08-18	Parameter Name	Time constant of speed feedforward filter			Property	During running	Control Mode	P
	Setting Range	0.00 to 64.00	Unit	ms	Effective Time	Immediate	Default	0.50

It sets time constant of speed feedforward filter.

H08-19	Parameter Name	Speed feedforward gain			Property	During running	Control Mode	P
	Setting Range	0.0 to 100.0	Unit	%	Effective Time	Immediate	Default	0.0

Speed feedforward is obtained by multiplying speed feedforward signal by H08-19 in position control and full closed-loop control. It is part of speed reference.

Increasing this parameter can improve response to position response and reduce position deviation at fixed speed.

During parameter adjustment, set H08-18 to a fixed value first and then increase H08-19 gradually from 0 until the speed feedforward effect is obtained.

It is recommended that H08-18 and H08-19 be set repeatedly until the best feedforward effect is obtained.

Note:

For the speed feedforward function, refer to H05-19 (Speed feedforward control selection).

H08-20	Parameter Name	Time constant of torque feedforward filter			Property	At stop	Control Mode	PS
	Setting Range	0.00 to 64.00	Unit	ms	Effective Time	Immediate	Default	0.50
It sets time constant of torque feedforward filter.								

H08-21	Parameter Name	Torque feedforward gain			Property	During running	Control Mode	PS
	Setting Range	0.0 to 200.0	Unit	%	Effective Time	Immediate	Default	0.0
<p>Torque feedforward is obtained by multiplying torque feedforward signal by H08-21 in non-torque control. It is part of torque reference.</p> <p>Increasing this parameter can improve response to changing speed reference.</p> <p>Increasing this parameter can improve response to position response and reduce position deviation at fixed speed.</p> <p>During parameter adjustment, set H08-20 to the default value first and then increase H08-21 gradually to increase effect of torque feedforward. When speed overshoot occurs, keep H08-21 unchanged and increase H08-20. It is recommended that H08-20 and H08-21 be set repeatedly until the best feedforward effect is obtained.</p> <p>Note:</p> <p>For torque feedforward , refer to H06-11 (Torque feedforward control selection).</p>								

H08-22	Parameter Name	Speed feedback filter			Property	At stop	Control Mode	PS												
	Setting Range	0 to 4	Unit	-	Effective Time	Immediate	Default	0												
<p>It sets times of performing moving average filter on speed feedback.</p> <p>The more the filter times are, the smaller speed feedback fluctuation and the larger the feedback delay will be.</p> <table border="1" data-bbox="558 1430 1253 1724"> <thead> <tr> <th>Value</th> <th>Meaning</th> </tr> </thead> <tbody> <tr> <td>0</td> <td>Disabled</td> </tr> <tr> <td>1</td> <td>Moving average filter of 2 speed feedbacks</td> </tr> <tr> <td>2</td> <td>Moving average filter of 4 speed feedbacks</td> </tr> <tr> <td>3</td> <td>Moving average filter of 8 speed feedbacks</td> </tr> <tr> <td>4</td> <td>Moving average filter of 16 speed feedbacks</td> </tr> </tbody> </table> <p>Note:</p> <p>When H08-22 > 0, H08-23 (Cutoff frequency of speed feedback low-pass filter) is invalid.</p>									Value	Meaning	0	Disabled	1	Moving average filter of 2 speed feedbacks	2	Moving average filter of 4 speed feedbacks	3	Moving average filter of 8 speed feedbacks	4	Moving average filter of 16 speed feedbacks
Value	Meaning																			
0	Disabled																			
1	Moving average filter of 2 speed feedbacks																			
2	Moving average filter of 4 speed feedbacks																			
3	Moving average filter of 8 speed feedbacks																			
4	Moving average filter of 16 speed feedbacks																			

H08-23	Parameter Name	Cutoff frequency of speed feedback low-pass filter			Property	During running	Control Mode	PS
	Setting Range	100 to 4000	Unit	Hz	Effective Time	Immediate	Default	4000

It sets the cutoff frequency of speed feedback first-order low-pass filter.

Note:

The smaller the setting of H08-23 is, the smaller speed feedback fluctuation and larger feedback delay will be caused.

If H08-23 = 4000 Hz, there is no filter effect.

H08-24	Parameter Name	PDFF control coefficient			Property	During running	Control Mode	PS
	Setting Range	0.0 to 100.0	Unit	-	Effective Time	Immediate	Default	100.0

It sets speed loop control mode.

When H08-24 = 100.0, PI control is used (default control mode in speed control). In this case, dynamic response is quick.

When H08-24 = 0.0, integration in speed control is enabled. In this case, low-frequency interference is filtered but dynamic response is slow.

Adjusting H08-24 helps to ensure quick response, minimize speed feedback overshoot and improve ability of filtering interference at low frequency for speed loop.

Group H09: Automatic Gain Tuning Parameters

H09-00	Parameter Name	Automatic gain tuning mode selection			Property	During running	Control Mode	PST
	Setting Range	0 to 2	Unit	-	Effective Time	Immediate	Default	0

It sets gain tuning mode. Related gain parameters can be set manually or be automatically tuned according to stiffness table.

Value	Meaning	Description
0	Disabled Gain parameters set manually	
1	Automatic gain tuning mode, gain parameters tuned automatically based on stiffness table	The 2nd gain does not follow stiffness table to change automatically.
2	Positioning mode, gain parameters tuned automatically based on stiffness table	The 2nd gain follows stiffness table to change automatically. It is one stiffness level higher than the 1st gain but does not exceed the highest stiffness level.

H09-01	Parameter Name	Stiffness level selection			Property	During running	Control Mode	PST
	Setting Range	0 to 31	Unit	-	Effective Time	Immediate	Default	12

It sets the stiffness level of servo system. The higher the stiffness level is, the stronger gain and quicker response will be obtained. But too strong stiffness will cause vibration.

0 indicates the weakest stiffness, and 31 indicates the strongest stiffness.

H09-02	Parameter Name	Mode selection of adaptive notch			Property	During running	Control Mode	PST
	Setting Range	0 to 4	Unit	-	Effective Time	Immediate	Default	0

It sets the working mode of adaptive notch.

Value	Meaning
0	Parameters not updated
1	Only one notch (3rd notch) valid, parameters updated in real time
2	Both notches (3rd and 4th notches) valid, parameters updated in real time
3	Only detect resonance frequency (displayed in H09-24)
4	Clear 3rd and 4th notches, restore parameters to default setting

H09-03	Parameter Name	Online inertia auto-tuning mode			Property	During running	Control Mode	PST
	Setting Range	0 to 3	Unit	-	Effective Time	Immediate	Default	0

It sets whether to enable online inertia auto-tuning and the inertia ratio update speed during online inertia auto-tuning.

Value	Meaning	Description
0	Disabled	-
1	Enabled, update slowly	It is applicable to applications where load inertia ratio almost does not change.
2	Enabled, always update	It is applicable to applications where load inertia ratio changes slowly.
3	Enabled, update quickly	It is applicable to applications where load inertia ratio changes quickly.

H09-04	Parameter Name	Suppression mode of low-frequency resonance			Property	During running	Control Mode	P
	Setting Range	0 to 1	Unit	-	Effective Time	Immediate	Default	0

It sets the suppression mode of low-frequency resonance.

Value	Meaning
0	Manually set parameters of low-frequency resonance suppression filter (H09-38 and H09-39)
1	Automatically set parameters of low-frequency resonance suppression filter (H09-38 and H09-39)

H09-05	Parameter Name	Offline inertia auto-tuning mode			Property	At stop	Control Mode	PST									
	Setting Range	0 to 1	Unit	-	Effective Time	Immediate	Default	0									
It sets the mode of offline inertia auto-tuning. The offline inertia auto-tuning function can be enabled in H0D-02.																	
<table border="1"> <thead> <tr> <th>Value</th> <th>Meaning</th> <th>Remark</th> </tr> </thead> <tbody> <tr> <td>0</td> <td>Positive/Negative triangular wave mode</td> <td>It is applicable to the application where motor moveable travel is short.</td> </tr> <tr> <td>1</td> <td>Jog mode</td> <td>It is applicable to the application where motor moveable travel is long.</td> </tr> </tbody> </table>									Value	Meaning	Remark	0	Positive/Negative triangular wave mode	It is applicable to the application where motor moveable travel is short.	1	Jog mode	It is applicable to the application where motor moveable travel is long.
Value	Meaning	Remark															
0	Positive/Negative triangular wave mode	It is applicable to the application where motor moveable travel is short.															
1	Jog mode	It is applicable to the application where motor moveable travel is long.															
For details on offline inertia auto-tuning, refer to section 6.2.1.																	

H09-06	Parameter Name	Maximum speed for inertia auto-tuning			Property	At stop	Control Mode	PST
	Setting Range	100 to 1000	Unit	RPM	Effective Time	Immediate	Default	500
It sets permissible maximum motor speed reference in offline inertia auto-tuning mode.								
The larger the motor speed is during inertia ratio, the more accurate auto-tuning result will be obtained. Set this parameter to the default value normally.								

H09-07	Parameter Name	Time constant of accelerating to max. speed for inertia auto-tuning			Property	At stop	Control Mode	PST
	Setting Range	20 to 800	Unit	ms	Effective Time	Immediate	Default	125
It sets the time for motor to accelerate from 0 to maximum speed for inertia auto-tuning (H09-06) in offline inertia auto-tuning mode.								

H09-08	Parameter Name	Interval after an inertia auto-tuning			Property	At stop	Control Mode	PST
	Setting Range	50 to 10000	Unit	ms	Effective Time	Immediate	Default	800
It sets time interval between two continuous speed references when H09-05 = 0 (positive and negative triangular wave mode) is used.								

H09-09	Parameter Name	Motor revolutions for an inertia auto-tuning			Property	At display	Control Mode	PST
	Setting Range	0.00 to 2.00	Unit	r	Effective Time	-	Default	-
It sets motor revolutions for single inertia auto-tuning when H09-05 = 0 (positive and negative triangular wave mode) is used.								
Note:								
When using offline inertia auto-tuning, ensure motor moveable trip at the stop position is larger than the setting of H09-09. Otherwise, decrease the setting of H09-06 or H09-07 appropriately until this requirement is satisfied.								

H09-12	Parameter Name	1st notch frequency			Property	During running	Control Mode	PS
	Setting Range	50 to 4000	Unit	Hz	Effective Time	Immediate	Default	4000
<p>It sets center frequency of the 1st notch, that is, mechanical resonance frequency.</p> <p>If H09-12 = 4000 Hz in torque control, the notch function is disabled.</p>								
H09-13	Parameter Name	1st notch width level			Property	During running	Control Mode	PS
	Setting Range	0 to 20	Unit	-	Effective Time	Immediate	Default	2
<p>It sets width level of the 1st notch. Set this parameter to the default value normally.</p> <p>Width level of notch is the ratio of notch width and notch center frequency</p>								
H09-14	Parameter Name	1st notch depth level			Property	During running	Control Mode	PS
	Setting Range	0 to 99	Unit	-	Effective Time	Immediate	Default	0
<p>It sets depth level of the 1st notch.</p> <p>Depth level of notch is the ratio of input and output at notch center frequency.</p> <p>The larger the setting of this parameter is, the smaller the notch depth is and the weaker suppression result on mechanical resonance will be. But too large setting may cause system instability.</p> <p>For the use or notch, refer to chapter 6.</p>								
H09-15	Parameter Name	2nd notch frequency			Property	During running	Control Mode	PS
	Setting Range	50 to 4000	Unit	Hz	Effective Time	Immediate	Default	4000
H09-16	Parameter Name	2nd notch width level			Property	During running	Control Mode	PS
	Setting Range	0 to 20	Unit	-	Effective Time	Immediate	Default	2
H09-17	Parameter Name	2nd notch depth level			Property	During running	Control Mode	PS
	Setting Range	0 to 99	Unit	-	Effective Time	Immediate	Default	0
<p>Description of the 2nd group of notch parameters is the same as that of the 1st group of notch parameters.</p>								
H09-18	Parameter Name	3rd notch frequency			Property	During running	Control Mode	PS
	Setting Range	50 to 4000	Unit	Hz	Effective Time	Immediate	Default	4000

H09-19	Parameter Name	3rd notch width level			Property	During running	Control Mode	PS
	Setting Range	0 to 20	Unit	-	Effective Time	Immediate	Default	2

H09-20	Parameter Name	3rd notch depth level			Property	During running	Control Mode	PS
	Setting Range	0 to 99	Unit	-	Effective Time	Immediate	Default	0

Refer to H09-12, H09-13 and H09-14 to understand the 3rd group of notch parameters.

Note:

The 3rd notch can be configured as adaptive notch (H09-02 = 1 or 2). In this case, notch parameters are updated automatically by the servo drive and cannot be modified manually. If notch frequency is 4000 Hz, the notch function is disabled.

H09-21	Parameter Name	4th notch frequency			Property	During running	Control Mode	PS
	Setting Range	50 to 4000	Unit	Hz	Effective Time	Immediate	Default	4000

H09-22	Parameter Name	4th notch width level			Property	During running	Control Mode	PS
	Setting Range	0 to 20	Unit	-	Effective Time	Immediate	Default	2

H09-23	Parameter Name	4th notch depth level			Property	During running	Control Mode	PS
	Setting Range	0 to 99	Unit	-	Effective Time	Immediate	Default	0

Refer to H09-12, H09-13 and H09-14 to understand the 4th group of notch parameters.

Note:

The 4th notch can be configured as adaptive notch (H09-02 = 1 or 2). In this case, notch parameters are set automatically by the servo drive and cannot be modified manually. If notch frequency is 4000 Hz, the notch function is disabled.

H09-24	Parameter Name	Obtained resonance frequency			Property	At display	Control Mode	PS
	Setting Range	0 to 2	Unit	Hz	Effective Time	-	Default	0

When H09-02 (Mode selection of adaptive notch) = 3, the current mechanical resonance frequency is displayed.

H09-30	Parameter Name	Torque disturbance compensation gain			Property	During running	Control Mode	PS
	Setting Range	0.0 to 100.0	Unit	%	Effective Time	Immediate	Default	0.0

It sets torque disturbance compensation gain in non-torque control.

Torque disturbance compensation can suppress impact of external disturbance torque on speed. The larger the setting of this parameter is, the better compensation effect and anti-interference performance will be obtained. But too large setting will cause vibration and noise. It must be used together with H09-31.

H09-31	Parameter Name	Time constant of torque disturbance observer filter			Property	During running	Control Mode	PS
	Setting Range	0.00 to 25.00	Unit	ms	Effective Time	Immediate	Default	0.50

It sets time constant of torque disturbance compensation filter in non-torque control.

This parameter has the smoothing effect on disturbance torque compensation (H09-30). The larger the setting of this parameter is, the more slowly disturbance torque compensation takes effect. But the noise will be reduced.

During parameter adjustment, set H09-31 to a large value first and then increase H09-30 gradually from 0 until the desired torque disturbance observer effect is obtained. Finally, in the prerequisite of ensuring valid torque disturbance observer, decrease H09-31 gradually.

H09-38	Parameter Name	Frequency of low-frequency resonance			Property	During running	Control Mode	P
	Setting Range	1.0 to 100.0	Unit	Hz	Effective Time	Immediate	Default	100.0

It sets frequency of low-frequency resonance suppression filter in position control and full closed-loop control. When H09-38 = 100.0 Hz, the filter is invalid.

When H09-04 (Suppression mode of low-frequency resonance) = 1 (Automatically set parameters of low-frequency resonance suppression filter), this parameter is set by the servo drive automatically.

H09-39	Parameter Name	Filter setting of low-frequency resonance			Property	During running	Control Mode	P
	Setting Range	0 to 10	Unit	-	Effective Time	Immediate	Default	2

It sets width level of low-frequency resonance suppression notch in position control and full closed-loop control. Set this parameter to the default value normally.

Value	Center Frequency for Suppression	Width for Suppression
0	H09-38	0, only vibration at center frequency suppressed
1 to 10	H09-38	H09-38 x H09-39 x 4%

A large setting of H09-39 can increase frequency range of low-frequency resonance suppression but cause long positioning time. A small setting cannot suppress low-frequency resonance in the application (such as belt) where vibration frequency of load changes. Thus, set this parameter repeatedly to seek the best effect.

When H09-04 (suppression mode of low-frequency resonance) = 1 (low-frequency resonance suppression parameters set automatically), this parameter is set by the servo drive automatically.

When H09-38 (frequency of low-frequency resonance) = 100.0 Hz, the filter is invalid.

Group H0A: Fault and Protection Parameters

H0A-00	Parameter name	Power input phase loss protection			Property	During running	Control Mode	-
	Setting Range	0 to 2	Unit	-	Effective Time	Immediate	Default	0

The main circuit power specifications vary according to the servo drive model; for details, refer to H01-02.

Our company provides servo drives of single-phase 220 V, three-phase 220 V, and three-phase 380 V voltage classes. When there is large fluctuation to the input voltage or phase loss occurs, the servo drive flexibly selects the protection mode based on the setting of this parameter.

Value	Protection Mode	Description
0	Enable faults and inhibit warnings	If the main circuit input voltage is single phase for the drive with rated power of 1 kW and above (H01-02 ≥ 6), Er.420 occurs.
1	Enable faults and warnings	If the main circuit input voltage is single phase for the drive with rated power of 1 kW and above (H01-02 ≥ 6), Er.420 occurs. If the main circuit input voltage is single phase for the drive with 0.75 kW rated power (H01-02 = 5), Er.990 occurs.
2	Inhibit faults and warnings	Both Er.420 and Er.990 are not detected. In common bus mode, set H0A-00 to 2. Otherwise, the servo drive cannot enter "rdy" state after power-on. Note that power-off discharge and power-off retentive are not supported when H0A-00 = 2.

Note:

When H0A-00 = 2, the servo drive supports separate power-on/off of the main circuit, that is, switching off the main circuit power supply, with the control circuit power being on.

When H0A-00 = 2, phase loss is not detected, and therefore, three-phase 220 V or three-phase 380 V input must be correct so that the modules will not be damaged.

H0A-03	Parameter name	Retentive at power failure			Property	During running	Control Mode	-
	Setting Range	0 to 1	Unit	-	Effective Time	Immediate	Default	0

It sets whether to enable the function of retentive at power failure.

Value	Meaning	Description
0	Disabled	The function of retentive at power failure is disabled.
1	Enabled	The function of retentive at power failure is enabled. The servo drive automatically stores the encoder feedback pulse count (H0B-17) at power failure, which can be viewed in the corresponding function code after power-on again.

H0A-04	Parameter name	Motor overload protection gain			Property	At stop	Control Mode	-
	Setting Range	50 to 300	Unit	%	Effective Time	Immediate	Default	100

It determines the motor overload duration before Er.620 is detected out.

Change the value to move up or delay the overload protection time based on the motor heating condition. The value 50% indicates half of the base time, and 150% indicates 1.5 times of the base time.

The setting must be based on the actual heating condition, and take caution during use.

H0A-08	Parameter name	Overspeed threshold			Property	During running	Control Mode	PST
	Setting Range	0 to 10000	Unit	RPM	Effective Time	Immediate	Default	0

It sets the motor speed threshold at which the overspeed fault is detected.

Value	Overspeed Threshold	Er.500 Detecting Condition
0	Maximum motor speed x 1.2	After detecting that the feedback speed is larger than the overspeed threshold for several times, the servo drive determines that Er.500 (Overspeed fault) occurs.
1 to 10000	If H0A-08 \geq (maximum motor speed x 1.2), the overspeed threshold is maximum motor speed x 1.2. If H0A-08 $<$ (maximum motor speed x 1.2), the overspeed threshold is H0A-08.	

H0A-09	Parameter name	Maximum position pulse frequency			Property	At stop	Control Mode	P
	Setting Range	100 to 4000	Unit	kHz	Effective Time	Immediate	Default	4000

It sets the maximum frequency of input pulses when the position reference source is pulse input (H05-00 = 0) in position control mode.

When the actual frequency exceeds H0A-09, the servo drive detects fault Er.B01.

H0A-10	Parameter name	Threshold of position deviation excess			Property	During running	Control Mode	P
	Setting Range	1 to 1073741824	Unit	Encoder unit	Effective Time	Immediate	Default	3145728

It sets the threshold of the position deviation excess fault in the position control mode.

When the position deviation exceeds the value, the servo drive detects Er.B00.

H0A-12	Parameter name	Runaway protection function			Property	During running	Control Mode	PST
	Setting Range	0 to 1	Unit	-	Effective Time	Immediate	Default	1

It sets whether to enable the runaway protection function.

Value	Meaning	Description
0	Disabled	In the applications where the motor drives vertical axis or is driven by load, set H0A-12 to 0 to disable runaway fault (Er.234) detection.
1	Enabled	Enable the runaway protection function.

H0A-16	Parameter name	Position deviation threshold for low-frequency resonance suppression			Property	During running	Control Mode	P
	Setting Range	1 to 1000	Unit	Encoder unit	Effective Time	Immediate	Default	5

It sets the position deviation threshold at which the servo drive detects low-frequency resonance when the automatic low-frequency resonance suppression function is used (H09-04 = 1).
When the speed deviation exceeds H0A-16, the servo drive determines that low-frequency resonance occurs.

H0A-19	Parameter name	DI8 filter time constant			Property	At stop	Control Mode	-
	Setting Range	0 to 255	Unit	25 ns	Effective Time	Power-on again	Default	80

H0A-20	Parameter name	DI9 filter time constant			Property	At stop	Control Mode	-
	Setting Range	0 to 255	Unit	25 ns	Effective Time	Power-on again	Default	80

DI8 and DI9 are high-speed DI terminals. When peak interference exists on the external input signals, set HA-19 or H0A-20 to eliminate peak interference.

Note:

The oscilloscope in the Inovance servo commissioning software displays DI8 and DI9 signals before filtering, and does not display signals of width lower than 0.25 ms.

H0A-24	Parameter name	Filter time constant of low-speed pulse input terminal			Property	At stop	Control Mode	P
	Setting Range	0 to 255	Unit	25 ns	Effective Time	Power-on again	Default	30

It sets the filter time constant of low-speed pulse input terminal which is used (H05-01 = 0) when the position reference source is pulse input (H05-00 = 0) in the position control mode.

When peak interference exists in the low-speed pulse input terminal, set this parameter to suppress peak interference and prevent motor malfunction due to interference signal input to the servo drive.

Maximum Frequency of Input Pulses	Recommended Filter Time Constant (Unit: 25 ns)
< 167 k	30
167 k to 250 k	20
250 k to 500 k	10

H0A-25	Parameter name	Filter time constant of speed feedback display			Property	At stop	Control Mode	-
	Setting Range	0 to 5000	Unit	ms	Effective Time	Immediate	Default	50

It sets the filter time constant of speed feedback signals to make the speed smoother.

H0B-00 displays the actual motor speed filtered by this parameter.

H0A-26	Parameter name	Motor overload shielding			Property	At stop	Control Mode	-
	Setting Range	0 to 1	Unit	-	Effective Time	Immediate	Default	0

It sets whether to shield motor overload detection.

Value	Meaning
0	Motor overload detection is enabled.
1	Detection of motor overload warning (Er.909) and fault (Er.620) is disabled.

Note:

Take caution when using the motor overload shielding function as it may easily lead to motor damage.

H0A-27	Parameter name	Filter time constant of speed DO			Property	At stop	Control Mode	-
	Setting Range	0 to 5000	Unit	ms	Effective Time	Immediate	Default	10

It sets the low-pass filter time constant of speed signals for the speed feedback and position reference.

This parameter is used for the speed-related DO signals (motor rotation output TGON, speed consistent V-CMP, speed reached V-ARR, and zero speed signal ZERO). For details on the four DO signals, refer to section 5.3.5.

H0A-27 defines the filter time for the position reference to convert to speed.

H0A-28	Parameter name	Filter time constant of quadrature encoder			Property	At stop	Control Mode	-
	Setting Range	0 to 255	Unit	25ns	Effective Time	Power-on again	Default	30

It is used to suppress peak interference on feedback signals from the incremental quadrature encoder.

The recommended filter time constants based on the actual motor speeds are listed as below:

Actual Motor Speed (RPM)	Recommended Filter Time Constant (25 ns)
4000 to 6000	20
< 4000	30

H0A-30	Parameter name	Filter time constant of high-speed pulse input terminal			Property	At stop	Control Mode	P
	Setting Range	0 to 255	Unit	25ns	Effective Time	Power-on again	Default	3

It sets the filter time constant of high-speed pulse input terminal which is used (H05-01 = 1) when the position reference source is pulse input (H05-00 = 0) in the position control mode.

When peak interference exists in the high-speed pulse input terminal, set this parameter to suppress peak interference and prevent motor malfunction due to interference signal input to the servo drive.

Maximum Frequency of Input Pulses	Recommended Filter Time Constant (Unit: 25 ns)
500 k to 1 M	5
> 1 M	3

H0A-32	Parameter name	Time threshold for locked rotor over-temperature protection			Property	During running	Control Mode	-
	Setting Range	10 to 65535	Unit	ms	Effective Time	Immediate	Default	200

It sets the time duration of locked-rotor over-temperature before it is detected by the servo drive. Decreasing this parameter makes the servo drive detect the fault more easily.

H0A-33	Parameter name	Locked rotor over-temperature protection			Property	During running	Control Mode	-
	Setting Range	0 to 1	Unit	-	Effective Time	Immediate	Default	1

It sets whether to enable detection of locked rotor over-temperature protection (Er.630).

Value	Meaning
0	Shield detection of locked rotor over-temperature protection (Er.630)
1	Enable detection of locked rotor over-temperature protection (Er.630)

H0A-36	Parameter name	Encoder multi-turn overflow fault selection			Property	At stop	Control Mode	PST
	Setting Range	0 to 1	Unit	-	Effective Time	Immediate	Default	0

Value	Meaning	Description
0	Not shield fault	-
1	Shield fault	When H02-01 = 1 and the multi-turn overflow fault need not be detected, set H01-36 to 1 to shield this fault.

H0A-40	Parameter name	Soft limit function			Property	At stop	Control Mode	PST
	Setting Range	0 to 2	Unit	1	Effective Time	Immediate	Default	0

H0A-41	Parameter name	Soft limit maximum value			Property	At stop	Control Mode	PST
	Setting Range	-2147483648 to 2147483647	Unit	1 reference unit	Effective Time	Immediate	Default	2147483648

H0A-42	Parameter name	Soft limit minimum value			Property	At stop	Control Mode	PST
	Setting Range	-2147483648 to 2147483647	Unit	1 reference unit	Effective Time	Immediate	Default	-2147483648

The values of H0A-40 are described as follows.

Value	Meaning	Description
0	Disabled	-
1	Enabled immediately at power-on	When the absolute position counter (H0B-07) is larger than H0A-41, the servo drive reports warning Er.950 and executes stop at forward limit. When the absolute position counter (H0B-07) is smaller than H0A-42, the servo drive reports warning Er.952 and executes stop at reverse limit.
2	Enabled after homing at power-on	When the absolute position counter (H0B-07) is larger than H0A-41 after homing is completed, the servo drive reports warning Er.950 and executes stop at forward limit. When the absolute position counter (H0B-07) is smaller than H0A-42 after homing is completed, the servo drive reports warning Er.952 and executes stop at reverse limit.

Group H0B: Monitoring Parameters

H0B-00	Parameter name	Actual motor speed			Type	Display	Control Mode	PST
	Setting Range	-	Unit	RPM			Default	-

It displays the actual speed of the servo motor after round-off, in unit of 1 RPM.
Set in H0A-25 the filter time constant for H0B-00.

H0B-01	Parameter name	Speed reference			Type	Display	Control Mode	PS
	Setting Range	-	Unit	RPM			Default	-

It displays the current speed reference of the drive (in unit of 1 RPM) in the position and speed modes.

H0B-02	Parameter name	Internal torque reference			Type	Display	Control Mode	PST
	Setting Range	-	Unit	%			Default	-

It displays the current torque reference, in unit of 0.1%. The value 100.0% corresponds to the rated motor torque.

H0B-03	Parameter name	Monitored DI states			Type	Display	Control Mode	PST
	Setting Range	-	Unit	-			Default	-

It displays the level states of the nine DI terminals without filtering.

The LED segment ON indicates high level ("1") and the lower LED segment ON indicates low level ("0").

For example, if DI1 is low level and DI2 to DI9 are high level, the binary value is 111111110, H0B-03 value read from Inovance servo commissioning software is 510, and the keypad display is as below:

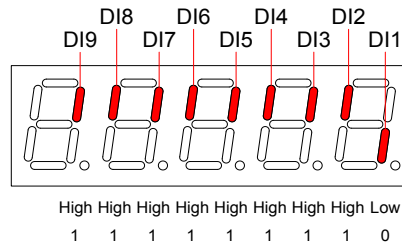

H0B-05	Parameter name	Monitored DO states			Type	Display	Control Mode	PST
	Setting Range	-	Unit	-			Default	-

It displays the level states of the five DO terminals without filtering.

The upper LED segment ON indicates high level ("1") and the lower LED segment ON indicates low level ("0").

For example, if DO1 is low level and DO2 to DO5 are high level, the binary value is 11110, H0B-05 value read from the Inovance servo commissioning software is 30, and the keypad display is as below:

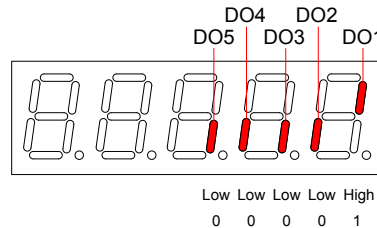

7

H0B-07	Parameter name	Absolute position counter			Type	Display	Control Mode	PST
	Setting Range	-	Unit	Reference unit			Default	-

It displays the current motor absolute position (reference unit) in the position control mode.

The setting is 32-bit data, and the keypad display is a decimal.

H0B-09	Parameter name	Mechanical angle			Type	Display	Control Mode	PST
	Setting Range	-	Unit	Encoder unit			Default	-
<p>It displays the current motor mechanical angle (encoder unit), and the value means mechanical angle 0°.</p> $\text{Actual mechanical angle} = \frac{\text{H0B-09}}{\text{H0B-09 max. value} + 1} \times 360.0^\circ$ <p>H0B-09 max. value: Encoder PPR x 4 – 1 (for example, for the 2500-PPR incremental encoder, the maximum H0B-09 value is 9999).</p> <p>Maximum H0B-09 value for absolute encoder: 65535</p>								

H0B-10	Parameter name	Electric angle			Type	Display	Control Mode	PST
	Setting Range	-	Unit	°			Default	-
<p>It displays the motor electric angle, in unit of 0.1°.</p> <p>The electric angle change range is ±360.0° during motor rotation. If the motor has four pairs of poles, each revolution produces four rounds of angle change from 0° to 359°. Similarly, if the motor has five pairs of poles, each revolution produces five rounds of angle change from 0° to 359°.</p>								

H0B-11	Parameter name	Speed corresponding to input position reference			Type	Display	Control Mode	P
	Setting Range	-	Unit	RPM			Default	-
<p>It displays the speed corresponding to the position references in one position control period in the position control mode.</p> <p>H0A-27 defines the filter time for the position reference to convert to speed.</p>								

H0B-12	Parameter name	Average load ratio			Type	Display	Control Mode	PST
	Setting Range	-	Unit	%			Default	-
<p>It displays the percentage of the average load torque relative to the rated motor torque, in unit of 0.1%. The value 100.0% corresponds to the rated motor torque.</p>								

H0B-13	Parameter name	Input position reference counter			Type	Display	Control Mode	P
	Setting Range	-	Unit	Reference unit			Default	-
<p>It counts and displays the number of position references not divided or multiplied by the electronic gear ratio during servo running in the position control mode.</p> <p>The setting is 32-bit data, and the keypad display is a decimal.</p>								

H0B-15	Parameter name	Encoder position deviation counter			Type	Display	Control Mode	P
	Setting Range	-	Unit	Encoder unit			Default	-
<p>It counts and displays the position deviation value after being divided or multiplied by the electronic gear ratio in the position control mode.</p> <p>The setting is 32-bit data, and the keypad display is a decimal.</p> <p>Note:</p> <p>Clearing H0B-15 is permissible when the condition defined in H05-16 is met.</p>								

H0B-17	Parameter name	Feedback pulse counter			Type	Display	Control Mode	PST
	Setting Range	-	Unit	Encoder unit			Default	-
<p>It counts the position pulses fed back by the encoder in any mode.</p> <p>The setting is 32-bit data, and the keypad display is a decimal.</p>								

H0B-19	Parameter name	Total power-on time			Type	Display	Control Mode	PST
	Setting Range	-	Unit	s			Default	-
<p>It displays the total operation time of the servo drive.</p> <p>The setting is 32-bit data, and the keypad display is a decimal.</p> <p>Note:</p> <p>If multiple times of power-on/off occur in the servo drive within a short time, there may be one-hour deviation between H0B-09 value and the actual time.</p>								

H0B-21	Parameter name	AI1 sampling voltage			Type	Display	Control Mode	PST
	Setting Range	-	Unit	V			Default	-
<p>It displays the AI1 sampling voltage, in unit of 0.01 V.</p>								

H0B-22	Parameter name	AI2 sampling voltage			Type	Display	Control Mode	PST
	Setting Range	-	Unit	V			Default	-
<p>It displays the AI2 sampling voltage, in unit of 0.01 V.</p>								

H0B-24	Parameter name	Phase current effective value			Type	Display	Control Mode	PST
	Setting Range	-	Unit	A			Default	-
<p>It displays the phase current effective value of the servo motor, in unit of 0.01 A.</p>								

H0B-26	Parameter name	Bus voltage			Type	Display	Control Mode	PST
	Setting Range	-	Unit	V			Default	-

It displays the DC bus voltage of the main circuit input voltage after rectification, in unit of 0.01 V.

H0B-27	Parameter name	Module temperature			Type	Display	Control Mode	PST
	Setting Range	-	Unit	°C			Default	-

It displays the temperature of the modules inside the servo drive, which can be used as the reference of current servo drive temperature.

H0B-33	Parameter name	Fault record			Property	During running	Control Mode	PST
	Setting Range	0 to 9	Unit	-	Effective Time	Immediate	Default	0

It selects the fault to be viewed among the latest 10 servo drive faults.

Value	Fault
0	Current fault
1	Latest fault
2	Last 2nd fault
.....
9	Last 9th fault

H0B-34	Parameter name	Fault code of selected fault record			Type	Display	Control Mode	PST
	Setting Range	-	Unit	-			Default	-

H0B-35	Parameter name	Time stamp upon displayed fault			Type	Display	Control Mode	PST
	Setting Range	-	Unit	s			Default	-

H0B-37	Parameter name	Motor speed upon displayed fault			Type	Display	Control Mode	PST
	Setting Range	-	Unit	RPM			Default	-

H0B-38	Parameter name	Motor phase U current upon displayed fault			Type	Display	Control Mode	PST
	Setting Range	-	Unit	A			Default	-

H0B-39	Parameter name	Motor phase V current upon displayed fault			Type	Display	Control Mode	PST
	Setting Range	-	Unit	A			Default	-

H0B-40	Parameter name	Bus voltage upon displayed fault			Type	Display	Control Mode	PST
	Setting Range	-	Unit	V			Default	-

H0B-41	Parameter name	Input terminal state upon displayed fault			Type	Display	Control Mode	PST
	Setting Range	-	Unit	-			Default	-

H0B-42	Parameter name	Output terminal state upon displayed fault			Type	Display	Control Mode	PST
	Setting Range	-	Unit	-			Default	-

H0B-34 to H0B-42 display the relevant data when the fault in H0B-34 occurs.

H0B-53	Parameter name	Position deviation counter			Type	Display	Control Mode	P
	Setting Range	-	Unit	Reference unit			Default	-

It displays the position deviation not processed by the electronic gear ration in the position control mode.

The setting is 32-bit data, and the keypad display is a decimal.

H0B-55	Parameter name	Actual motor speed			Type	Display	Control Mode	PST
	Setting Range	-	Unit	RPM			Default	-

It displays the actual motor speed, in unit of 0.1 RPM.

The setting is 32-bit data, and the keypad display is a decimal.

H0A-25 defines the filter time for the speed feedback.

H0B-58	Parameter name	Mechanical absolute position (low 32 bits)			Type	Display	Control Mode	PST
	Setting Range	-	Unit	1 encoder unit			Default	0

It displays the low 32-bit data of the mechanical position feedback (encoder unit) when the absolute encoder is used.

H0B-60	Parameter name	Mechanical absolute position (high 32 bits)			Type	Display	Control Mode	PST
	Setting Range	-	Unit	1 encoder unit			Default	0
It displays the high 32-bit data of the mechanical position feedback (encoder unit) when the absolute encoder is used.								

H0B-64	Parameter name	Real-time input position reference counter			Type	Display	Control Mode	PST
	Setting Range	-	Unit	Reference unit			Default	-
It displays the position reference counter before being divided or multiplied by the electronic gear ratio. It is irrelative to the current servo state and control mode.								

H0B-70	Parameter name	Number of absolute encoder turns			Type	Display	Control Mode	PST
	Setting Range	-	Unit	1 rev			Default	-
It displays the number of absolute encoder turns.								

H0B-71	Parameter name	Position of absolute encoder within one turn			Type	Display	Control Mode	PST
	Setting Range	-	Unit	1 encoder unit			Default	-
It displays the position feedback of the absolute encoder within one turn.								

H0B-77	Parameter name	Absolute position (low 32 bits) of absolute encoder			Type	Display	Control Mode	PST
	Setting Range	-	Unit	1 encoder unit			Default	-
It displays the low 32-bit data of the position feedback of the absolute encoder.								

H0B-79	Parameter name	Absolute position (high 32 bits) of absolute encoder			Type	Display	Control Mode	PST
	Setting Range	-	Unit	1 encoder unit			Default	-
It displays the high 32-bit data of the position feedback of the absolute encoder.								

H0B-81	Parameter name	Rotating load single-turn position (low 32 bits)			Type	Display	Control Mode	PST
	Setting Range	-	Unit	1 encoder unit			Default	-
It displays the low 32-bit data of the position feedback of the rotating load when the absolute system works in rotating mode.								

H0B-83	Parameter name	Rotating load single-turn position (high 32 bits)			Type	Display	Control Mode	PST
	Setting Range	-	Unit	1 encoder unit			Default	-
It displays the high 32-bit data of the position feedback of the rotating load when the absolute system works in rotating mode.								

H0B-85	Parameter name	Rotating load single-turn position			Type	Display	Control Mode	PST
	Setting Range	-	Unit	1 reference unit			Default	-
It displays the position feedback data of the rotating load when the absolute system works in rotating mode.								

Group H0C: Communication Parameters

H0C-00	Parameter name	Servo axis address			Property	During running	Control Mode	PST
	Setting Range	1 to 247	Unit	-	Effective Time	Immediate	Default	1
It sets the axis address of the servo drive. 0: broadcast address. The host controller writes all servo drives through the broadcast address; the servo drives act after receiving the frame with the broadcast address and do not return a response. 1 to 247: Each of the multiple servo drives networked must have a unique address; otherwise, communication abnormality or failure will occur.								

H0C-02	Parameter name	Serial baud rate			Property	During running	Control Mode	PST														
	Setting Range	0 to 5	Unit	-	Effective Time	Immediate	Default	5														
It sets the communication rate between the servo drive and the host controller.																						
<table border="1" style="margin-left: auto; margin-right: auto;"> <thead> <tr> <th>Value</th> <th>Baud Rate</th> </tr> </thead> <tbody> <tr> <td>0</td> <td>2400 Kbps</td> </tr> <tr> <td>1</td> <td>4800 Kbps</td> </tr> <tr> <td>2</td> <td>9600 Kbps</td> </tr> <tr> <td>3</td> <td>19200 Kbps</td> </tr> <tr> <td>4</td> <td>38400 Kbps</td> </tr> <tr> <td>5</td> <td>57600 Kbps</td> </tr> </tbody> </table>									Value	Baud Rate	0	2400 Kbps	1	4800 Kbps	2	9600 Kbps	3	19200 Kbps	4	38400 Kbps	5	57600 Kbps
Value	Baud Rate																					
0	2400 Kbps																					
1	4800 Kbps																					
2	9600 Kbps																					
3	19200 Kbps																					
4	38400 Kbps																					
5	57600 Kbps																					
The baud rate set in the servo drive must be the same as that in the host controller. Otherwise, communication will fail.																						

H0C-03	Parameter name	Modbus data format			Property	During running	Control Mode	PST
	Setting Range	0 to 3	Unit	-	Effective Time	Immediate	Default	0

It sets the data check format between the servo drive and the host controller.

Value	Data Format
0	No check, 2 stop bits
1	Even parity check, 1 stop bit
2	Odd parity check, 1 stop bit
3	No check, 1 stop bit

The data format set in the servo drive must be the same as that in the host controller. Otherwise, communication will fail.

H0C-08	Parameter name	CAN communication rate			Property	During running	Control Mode	PST
	Setting Range	0 to 7	Unit	-	Effective Time	Immediate	Default	5

It sets the CAN (CANlink or CANopen) communication rate between the servo drive and the host controller.

Value	Communication Rate
0	20 K
1	50 K
2	100 K
3	125 K
4	250 K
5	500 K
6	1 M
7	1 M

The communication rate set in the servo drive must be the same as that in the host controller. Otherwise, communication will fail.

H0C-09	Parameter name	Communication VDI			Property	At stop	Control Mode	PST
	Setting Range	0 to 1	Unit	-	Effective Time	Immediate	Default	0

It sets whether to use the virtual digital input (VDI).

Value	Meaning
0	Disabled
1	Enabled

H0C-10	Parameter name	VDI default value after power-on			Property	During running	Control Mode	PST
	Setting Range	0 to 65535	Unit	-	Effective Time	Power-on again	Default	0

It sets the VDI default value after power-on.

Use the VDI according to the following procedure:

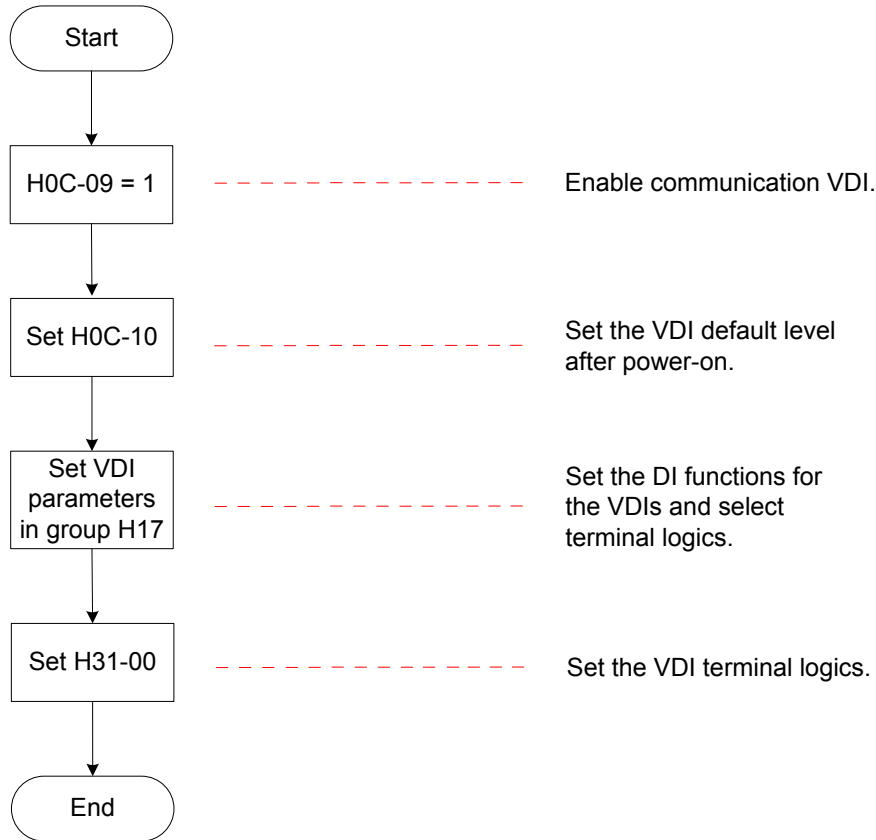

The VDI terminal logic is determined by H0C-10 upon first-time power-on and then determined by H31-00.

H0C-10 value displayed on the keypad is decimal, and H31-00 is not displayed on the keypad. In the converted binary value of H0C-10 (H31-00), bit(n) = 1 indicates that terminal VDI(n+1) logic is 1, and bit(n) = 0 indicates that terminal VDI(n+1) logic is 0.

7

H0C-11	Parameter name	Communication VDO			Property	At stop	Control Mode	PST
	Setting Range	0 to 1	Unit	-	Effective Time	Immediate	Default	0

It sets whether to use the virtual digital output (VDO).

Value	Meaning
0	Disabled
1	Enabled

H0C-12	Parameter name	Default level of VDO allocated with function 0			Property	At stop	Control Mode	PST
	Setting Range	0 to 65535	Unit	-	Effective Time	Immediate	Default	0

It sets the default virtual level of the VDO allocated with function 0 (invalid).

Use the VDO according to the following procedure:

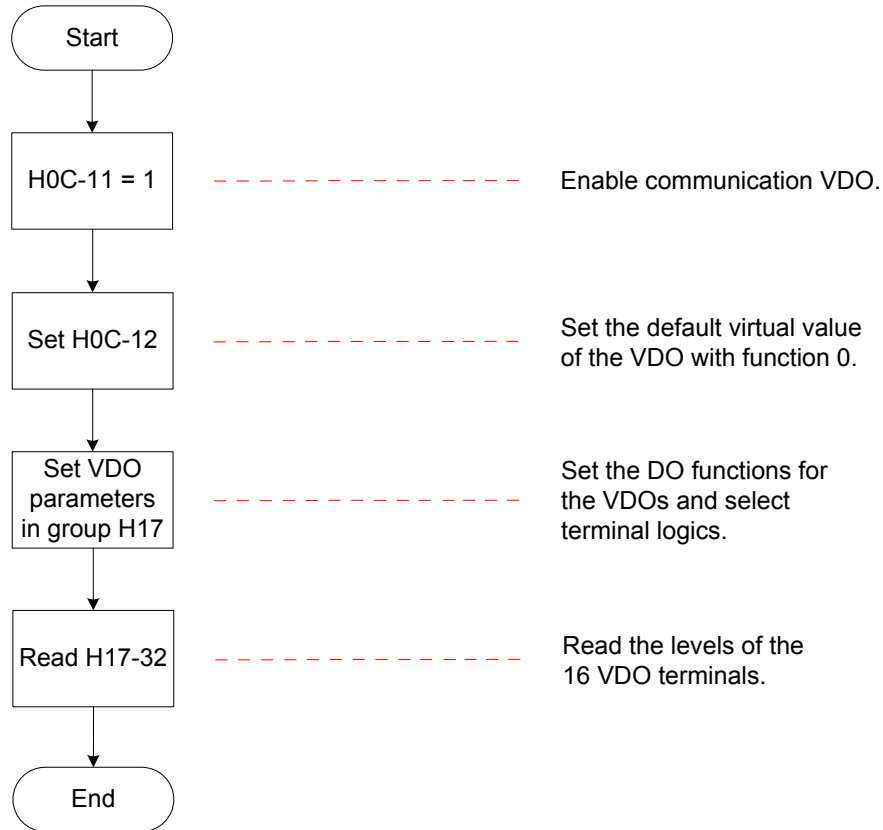

H0C-12 (H17-32) value displayed on the keypad is hexadecimal. In the converted binary value of H0C-12 (H17-32), bit(n) = 1 indicates that terminal VDO(n+1) logic is 1, and bit(n) = 0 indicates that terminal VDO(n+1) logic is 0.

It is recommended that the VDO logic levels in group H17 are opposite to H0C-12 to facilitate differentiation.

H0C-13	Parameter name	Update function code values written via communication to EEPROM			Property	During running	Control Mode	PST						
	Setting Range	0 to 1	Unit	-	Effective Time	Immediate	Default	1						
<p>It sets whether to store the function codes written via communication to EEPROM.</p> <table border="1"> <thead> <tr> <th>Value</th> <th>Meaning</th> </tr> </thead> <tbody> <tr> <td>0</td> <td>Not update the function codes written via communication to EEPROM</td> </tr> <tr> <td>1</td> <td>Update the function codes written via communication, except groups H0B and H0D to EEPROM</td> </tr> </tbody> </table> <p>Note: The change of H0C-13 is always updated to EEPROM. If the function codes changed need not be retentive at power failure, set H0C-13 to 0. Otherwise, frequently updating a large number of changed function codes to EEPROM will damage EEPROM, and the servo drive detects Er.108.</p>									Value	Meaning	0	Not update the function codes written via communication to EEPROM	1	Update the function codes written via communication, except groups H0B and H0D to EEPROM
Value	Meaning													
0	Not update the function codes written via communication to EEPROM													
1	Update the function codes written via communication, except groups H0B and H0D to EEPROM													

H0C-14	Parameter name	Modbus error code			Property	At display	Control Mode	-												
	Setting Range	0 to 65535	Unit	1	Effective Time		Default	-												
<p>It displays the error code when a communication fault occurs. The error code is defined as below:</p> <table border="1"> <thead> <tr> <th>New Protocol (Standard)</th> <th>Old Protocol</th> </tr> </thead> <tbody> <tr> <td>0x0001: Illegal command code</td> <td>0x0002: Command code not being 0x03/0x06/0x10</td> </tr> <tr> <td>0x0002: Illegal data address</td> <td>0x0004: CRC checksum received and calculated by servo different from checksum in data frame</td> </tr> <tr> <td>0x0003: Illegal data</td> <td>0x0008: Accessed function code not exist</td> </tr> <tr> <td>0x0004: Slave station device fault</td> <td>0x0010: Written function code value exceed limits</td> </tr> <tr> <td></td> <td>0x0080: Written function code modifiable only in stop state but servo being in running state</td> </tr> </tbody> </table> <p>The H0C-14 value displayed on the keypad is hexadecimal.</p>									New Protocol (Standard)	Old Protocol	0x0001: Illegal command code	0x0002: Command code not being 0x03/0x06/0x10	0x0002: Illegal data address	0x0004: CRC checksum received and calculated by servo different from checksum in data frame	0x0003: Illegal data	0x0008: Accessed function code not exist	0x0004: Slave station device fault	0x0010: Written function code value exceed limits		0x0080: Written function code modifiable only in stop state but servo being in running state
New Protocol (Standard)	Old Protocol																			
0x0001: Illegal command code	0x0002: Command code not being 0x03/0x06/0x10																			
0x0002: Illegal data address	0x0004: CRC checksum received and calculated by servo different from checksum in data frame																			
0x0003: Illegal data	0x0008: Accessed function code not exist																			
0x0004: Slave station device fault	0x0010: Written function code value exceed limits																			
	0x0080: Written function code modifiable only in stop state but servo being in running state																			

7

H0C-25	Parameter name	Modbus response delay			Property	During running	Control Mode	PST
	Setting Range	0 to 5000	Unit	1	Effective Time	Immediate	Default	1
<p>It sets the delay from the moment when the slave receives a command from the host controller to the moment when the slave returns a response.</p>								

H0C-26	Parameter name	Modbus communication data sequence			Property	During running	Control Mode	PST
	Setting Range	0 to 1	Unit	1	Effective Time	Immediate	Default	1

It sets the 32-bit data transmission format of Modbus communication.

Value	32-Bit Data Sequence
0	High 16 bits before low 16 bits
1	Low 16 bits before high 16 bits

H0C-30	Parameter name	Modbus error frame format			Property	During running	Control Mode	PST
	Setting Range	0 to 1	Unit	1	Effective Time	Immediate	Default	1

It sets the protocol for reporting communication errors.

Value	Meaning
0	Old protocol
1	New protocol (standard)

Group H0D: Auxiliary Function Parameters

H0D-00	Parameter name	Software reset			Property	At stop	Control Mode	-
	Setting Range	0 to 1	Unit	-	Effective Time	Immediate	Default	0

It sets whether to support software reset.

Value	Meaning	Descriptions
0	Disabled	The servo drive automatically performs program reset (similar to program reset at power-on) without requiring power-off/on again.
1	Enabled	

The conditions precedent are as below:
 The servo is in OFF state.
 There is no non-resettable fault such as No. 1 fault.
 No EEPROM operation is performed. The software reset function is invalid when H0A-03 = 1.

H0D-01	Parameter name	Fault reset			Property	At stop	Control Mode	-
	Setting Range	0 to 1	Unit	-	Effective Time	Immediate	Default	0

It sets whether to support fault reset.

Value	Meaning	Description
0	Disabled	No. 1 and No. 2 resettable faults can be reset when the servo drive is not in running state after the causes are eliminated. Then, the servo drive do not display the faults and enters the "rdy" state. No. 3 warnings can be reset directly regardless of the servo state.
1	Enabled	

Note:

For fault classification, refer to Chapter 8.

After fault reset, the keypad stops displaying the fault only, but parameter change still does not take effect.

This function is invalid to non-resettable faults. Take caution with this function if the fault causes are not removed.

H0D-02	Parameter name	Offline inertia auto-tuning enable			Property	During running	Control Mode	-
	Setting Range	-	Unit	-	Effective Time	Immediate	Default	-

In parameter setting mode, after you switch to H0D-02 and press key SET, offline inertia auto-tuning is enabled.

For details, refer to section 6.2.1.

H0D-03	Parameter name	Reserved parameter			Property	-	Control Mode	-
	Setting Range	-	Unit	-	Effective Time	-	Default	-

H0D-05	Parameter name	Emergency stop			Property	During running	Control Mode	-
	Setting Range	0 to 1	Unit	-	Effective Time	Immediate	Default	0

It sets whether to enable emergency stop.

Value	Meaning
0	Disabled
1	Enabled, stop mode determined in H02-05 regardless of its state

H0D-10	Parameter name	Analog automatic adjustment			Property	At stop	Control Mode	-								
	Setting Range	0 to 1	Unit	-	Effective Time	Immediate	Default	0								
It sets whether to enable automatic adjustment of analogs and selects the analog to be adjusted.																
<table border="1"> <thead> <tr> <th>Value</th> <th>Meaning</th> </tr> </thead> <tbody> <tr> <td>0</td> <td>Disabled</td> </tr> <tr> <td>1</td> <td>AI1 adjustment</td> </tr> <tr> <td>2</td> <td>AI2 adjustment</td> </tr> </tbody> </table>									Value	Meaning	0	Disabled	1	AI1 adjustment	2	AI2 adjustment
Value	Meaning															
0	Disabled															
1	AI1 adjustment															
2	AI2 adjustment															
When the analog automatic adjustment function is enabled, the servo drive automatically corrects the zero drift of the analog to improve signal detection accuracy. The value after adjustment is automatically stored into the corresponding function code (H03-54 or H03-59) in the servo drive.																

H0D-11	Parameter name	Jog function			Property	-	Control Mode	-
	Setting Range	-	Unit	-	Effective Time	-	Default	-
In parameter setting mode, after you switch to H0D-11 and press key SET, jog running is enabled. For details, refer to section 4.5.1.								
This function is irrelevant to the servo control mode.								

H0D-17	Parameter name	Forced DI/DO setting			Property	During running	Control Mode	-										
	Setting Range	0 to 3	Unit	-	Effective Time	Immediate	Default	0										
It sets whether to enable forced DI/DO.																		
<table border="1"> <thead> <tr> <th>Value</th> <th>Meaning</th> </tr> </thead> <tbody> <tr> <td>0</td> <td>Disabled</td> </tr> <tr> <td>1</td> <td>Forced DI enabled, forced DO disabled</td> </tr> <tr> <td>2</td> <td>Forced DO enabled, forced DI disabled</td> </tr> <tr> <td>3</td> <td>Forced DI and DO enabled</td> </tr> </tbody> </table>									Value	Meaning	0	Disabled	1	Forced DI enabled, forced DO disabled	2	Forced DO enabled, forced DI disabled	3	Forced DI and DO enabled
Value	Meaning																	
0	Disabled																	
1	Forced DI enabled, forced DO disabled																	
2	Forced DO enabled, forced DI disabled																	
3	Forced DI and DO enabled																	

H0D-18	Parameter name	Forced DI level			Property	During running	Control Mode	-
	Setting Range	0 to 0x01FF	Unit	-	Effective Time	Immediate	Default	0x01FF

It sets the levels of the DI functions set in group H03 when forced DI is valid (H0D-17=1 or 3).
H0D-18 value displayed on the keypad is hexadecimal. In the converted binary value, bit(n) = 1 indicates that the level of the DI function is high level, and bit(n) = 0 indicates that the level of the DI function is low level.

Example:
H0D-18 value is 0x01FE, and the corresponding binary value is 11111110, indicating that DI1 is low level and DI2 to DI9 are high level. The nine DI levels can also be monitored through H0B-03.

High High High High High High High High Low
1 1 1 1 1 1 1 1 0

View also the DI terminal logic in group H03 when checking whether a DI function is valid.

H0D-19	Parameter name	Forced DO setting			Property	During running	Control Mode	-
	Setting Range	0 to 0x001F	Unit	-	Effective Time	Immediate	Default	0

It sets whether the DO functions allocated in group H04 are valid when forced DO is valid (H0D-17= 2 or 3).
H0D-19 value displayed on the keypad is hexadecimal. In the converted binary value, bit(n) = 1 indicates that the DO function is valid, and bit(n) = 0 indicates that the DO function is invalid..

Example:
If H0D-19 value is 0x1E, the corresponding binary is 11110, indicating that the DO1 function is invalid and functions of DO2 to DO5 are valid. The DO levels obtained based on the DO logics in group H04 and viewed in H0B-05 is shown as below:
Assume that DO1 to DO5 logics in group H04 are: 0 indicating low level output at function valid.

Low Low Low Low High
0 0 0 0 1

H0D-20	Parameter name	Absolute encoder reset function			Property	At stop	Control Mode	ALL
	Setting Range	0 to 2	Unit	-	Effective Time	Immediate	Default	0

It sets whether to reset encoder internal faults or multi-turn data.

Note that if the encoder feedback multi-turn data is reset, the absolute position of the encoder changes greatly, and the mechanical homing operation is required in this case.

Value	Meaning
0	Disabled
1	Reset faults
2	Reset faults and multi-turn data

Group H0F: Full Closed-Loop Parameters

H0F-00	Parameter name	Encoder feedback mode			Property	At stop	Control Mode	P
	Setting Range	0 to 2	Unit	-	Effective Time	Immediate	Default	0

It sets the encoder feedback signal source in full closed-loop control.

Value	Meaning	Description
0	Internal encoder feedback	The position feedback signals come from the internal encoder of the motor.
1	External encoder feedback	The position feedback signals come from the full closed-loop external encoder. 1st electronic gear ratio is used.
2	Internal/External switchover at electronic gear ratio switchover	The DI with function 24 (FunIN.24: GEAR_SEL) is used to control switchover. DI invalid: internal encoder feedback, using 1st electronic gear ratio DI valid: internal encoder feedback, using 2nd electronic gear ratio

Note:

In full closed-loop control mode, the position references are from the internal, and the speed reference unit is the internal encoder unit.

Conversion is required during the speed setting; otherwise, an error will occur during running.

H0F-01	Parameter name	Running direction of external encoder			Property	At stop	Control Mode	P
	Setting Range	0 to 1	Unit	-	Effective Time	Immediate	Default	0

It sets the counting direction of feedback pulses from the external encoder relative to the internal encoder during motor rotation.

Value	Meaning	Description
0	Standard running direction	During motor rotation, the pulse feedback counter of the external encoder (H0F-20) has the same direction as the internal encoder (H0F-18).
1	Reverse running direction	During motor rotation, the pulse feedback counter of the external encoder (H0F-20) has the opposite direction as the internal encoder (H0F-18).

Note:

1. Ensure to make check before trial running. For details on the operation, refer to Chapter 5.
2. Incorrect setting of this function will cause a runaway accident.

H0F-04	Parameter name	External encoder pulses per one motor revolution			Property	At stop	Control Mode	P
	Setting Range	0 to 1073741824	Unit	External encoder unit	Effective Time	Power-on again	Default	10000

It sets the feedback pulses from the external encoder that causes one turn of the motor shaft.

This parameter defines the count relationship between feedback pulses from the external encoder and those from the internal encoder.

Calculate the value based on analysis of mechanical parameters. When it is rigid coupling between the motor and the external encoder (scale), you can also set as below:

1) Manually rotate the motor and observe H0F-18 (Feedback pulse counter of internal encoder) meanwhile. After ensuring that the motor rotates for a turn (H0F-18 = servo motor resolution), calculate the change of H0F-20 (Feedback pulse counter of external encoder).

The absolute calculated data is the value of H0F-04.

2) If H0F-18 = X1, H0F-20 = Y1 before rotating the motor, and H0F-18 = X2, H0F-20 = Y2 after rotating the motor:

$$H0F-04 = \text{Servo motor resolution} \times (Y2 - Y1) / (X2 - X1)$$

The calculated data must be positive; if not, perform the first step again.

There is a deviation with the data calculated by using this method for non-rigid connection.

Note:

Ensure correct setting of H0F-04. Otherwise, Er.B02 may occur after servo running.

H0F-08	Parameter name	Full closed-loop position deviation excess threshold			Property	During running	Control Mode	P
	Setting Range	0 to 1073741824	Unit	External encoder unit	Effective Time	Immediate	Default	10000

It sets the position deviation threshold at which the servo drive detects fault Er.B02 indicating that the position deviation is excessive.

When H0F-08 = 0, the servo drive does not detect Er.B02 and always clears the full closed-loop position deviation.

H0F-10	Parameter name	Full closed-loop position deviation clear setting			Property	During running	Control Mode	P
	Setting Range	0 to 100	Unit	r	Effective Time	Immediate	Default	0

As the motor turns the number of revolutions set by this parameter, the servo drive clears the full closed-loop position deviation to 0. The number of revolutions is expressed by the internal encoder feedback pulses in H0F-18.

Value n	Meaning
0	The servo drive always clears the full closed-loop position deviation.
1 to 100	If the position deviation remains smaller than H0F-08 after the motor turns n revolutions, the servo drive clears the position deviation at the nth resolution, and counts the position deviation and number of motor revolutions from 0 again.
	Once the position deviation becomes larger than H0F-08 after the motor turns n revolutions, the servo drive immediately clears the position deviation. If external encoder feedback (H0F-00 = 1 or 2) is used, Er.B02 will occur.

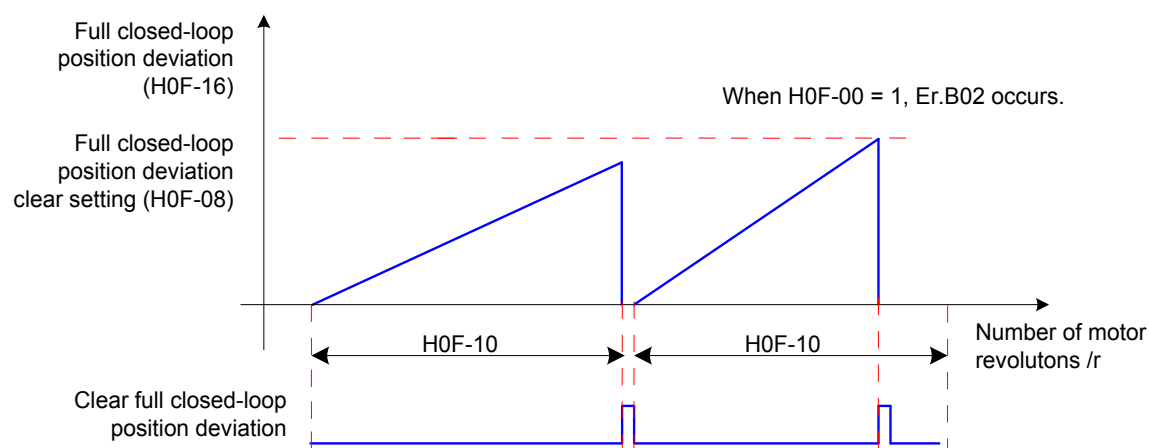

Note:

The number of motor revolutions will not be cleared to 0 when the servo drive is not in running state.

For example, assume that H0F-10 = 10:

If the motor turns for five revolutions when the S-ON signal becomes inactive, the servo drive clears the data to 0 when the motor turns for another five revolution after the S-ON signal resumes active.

Then, the servo drive clears the value for each 10 motor revolutions.

H0F-13	Parameter name	Filter time constant of hybrid vibration suppression			Property	At stop	Control Mode	P
	Setting Range	0 to 6553.5	Unit	ms	Effective Time	Immediate	Default	0

It sets the time constant for suppressing full closed-loop hybrid vibration when external encoder feedback (H0F-00 = 1 or 2).

Increase the value gradually and check the response change.

H0F-16	Parameter name	Full closed-loop position deviation counter			Property	Display	Control Mode	P
	Setting Range	-1073741824 to 1073741824	Unit	External encoder unit	Effective Time		Default	0
<p>It counts and displays the position deviation absolute value in full closed-loop control.</p> <p>Full closed-loop position deviation = Absolute position feedback of external encoder – Converted value of absolute position feedback of internal encoder</p> <p>Note:</p> <p>"Hybrid control pulse deviation" displayed in Inovance servo commissioning software has the same definition as H0F-16.</p> <p>If internal encoder feedback is used, H0F-08 = 0 or H0F-10 = 0, H0F-16 value is always 0.</p>								

H0F-18	Parameter name	Feedback pulse counter of internal encoder			Property	Display	Control Mode	P
	Setting Range	-1073741824 to 1073741824	Unit	Internal encoder unit	Effective Time		Default	0
<p>It counts and displays the feedback pulses of the internal encoder (after divided or multiplied by electronic gear ratio, in internal encoder unit).</p>								

H0F-20	Parameter name	Feedback pulse counter of external encoder			Property	Display	Control Mode	P
	Setting Range	-1073741824 to 1073741824	Unit	External encoder unit	Effective Time	-	Default	0
<p>It counts and displays the feedback pulses of the external encoder (after divided or multiplied by electronic gear ratio, in internal encoder unit).</p>								

Group H11: Multi-Position Function Parameters

H11-00	Parameter name	Multi-position running mode			Property	At stop	Control Mode	P										
	Setting Range	0 to 3	Unit	-	Effective Time	Immediate	Default	1										
<p>It sets the multi-position running mode when the main position reference source is multi-position (H05-00 = 2) in position control mode.</p> <table border="1" style="margin-left: auto; margin-right: auto;"> <thead> <tr> <th>Value</th> <th>Meaning</th> </tr> </thead> <tbody> <tr> <td>0</td> <td>Stop after running single cycle</td> </tr> <tr> <td>1</td> <td>Cyclic running</td> </tr> <tr> <td>2</td> <td>DI switchover</td> </tr> <tr> <td>3</td> <td>Sequential running</td> </tr> </tbody> </table> <p>For details, see the descriptions in section 5.2.1.</p>									Value	Meaning	0	Stop after running single cycle	1	Cyclic running	2	DI switchover	3	Sequential running
Value	Meaning																	
0	Stop after running single cycle																	
1	Cyclic running																	
2	DI switchover																	
3	Sequential running																	

H11-01	Parameter name	Number of position reference profile			Property	At stop	Control Mode	P																													
	Setting Range	1 to 16	Unit	-	Effective Time	Immediate	Default	1																													
<p>It sets the total number of position reference profile. You can set different displacements, running speed, and acceleration/deceleration time for each position.</p> <p>H11-00 ≠ 2, switchover between position No. is performed automatically, with the sequence from 1, 2, ..., to H11-01.</p> <p>H11-00 = 2, set four DIs (hardware DI or VDI) with functions 6 to 9 (FunIN.6:CMD1 to FunIN.9:CMD4) and control the DI logics on the host controller to implement switchover between position No. The position No. is a 4-bit binary value, and the relationship between CMD1 to CMD4 and the position No. is listed in the following table.</p> <table border="1" data-bbox="437 741 1362 987"> <thead> <tr> <th>FunIN.9</th> <th>FunIN.8</th> <th>FunIN.7</th> <th>FunIN.6</th> <th rowspan="2">Position No.</th> </tr> <tr> <th>CMD4</th> <th>CMD3</th> <th>CMD2</th> <th>CMD1</th> </tr> </thead> <tbody> <tr> <td>0</td> <td>0</td> <td>0</td> <td>0</td> <td>1</td> </tr> <tr> <td>0</td> <td>0</td> <td>0</td> <td>1</td> <td>2</td> </tr> <tr> <td colspan="5" style="text-align: center;">.....</td> </tr> <tr> <td>1</td> <td>1</td> <td>1</td> <td>1</td> <td>16</td> </tr> </tbody> </table> <p>CMD(n) is 1 when the DI terminal logic is valid and 0 when the DI terminal logic is invalid.</p>									FunIN.9	FunIN.8	FunIN.7	FunIN.6	Position No.	CMD4	CMD3	CMD2	CMD1	0	0	0	0	1	0	0	0	1	2					1	1	1	1	16
FunIN.9	FunIN.8	FunIN.7	FunIN.6	Position No.																																	
CMD4	CMD3	CMD2	CMD1																																		
0	0	0	0	1																																	
0	0	0	1	2																																	
.....																																					
1	1	1	1	16																																	

H11-02	Parameter name	Margin processing method			Property	At stop	Control Mode	P									
	Setting Range	0 to 1	Unit	-	Effective Time	Immediate	Default	0									
<p>It sets the start position No. when the multi-function running recovers after a pause.</p> <p>Pause:</p> <ol style="list-style-type: none"> The servo drive switches over to another control mode or the position change on fly function is enabled during multi-position running. The internal multi-position enable signal (FunIN.28:PosInSen) changes from active from inactive. <table border="1" data-bbox="383 1464 1432 1740"> <thead> <tr> <th>Value</th> <th>Meaning</th> <th>Description</th> </tr> </thead> <tbody> <tr> <td>0</td> <td>Complete the remaining distance</td> <td>For example, if H11-01 = 16 and the servo drive pauses when running to the 2nd position, it starts running from the 3rd position after restoring the multi-position running.</td> </tr> <tr> <td>1</td> <td>Start running again from 1st position</td> <td>For example, if H11-01 = 16 and the servo drive pauses when running to the 2nd position, it starts running from the 1st position after restoring the multi-position running.</td> </tr> </tbody> </table> <p>Note:</p> <p>Once the servo drive pauses during the multi-position running, it discards the uncompleted distance in the current position reference.</p> <p>H11-00 = 2 (DI switchover), pause is permissible only when the servo drive switches over to another control mode or the position change on fly function is enabled during running of the current position. The start position No. is determined by FunIN.6 to FunIN.9 after the multi-position running is restored.</p>									Value	Meaning	Description	0	Complete the remaining distance	For example, if H11-01 = 16 and the servo drive pauses when running to the 2nd position, it starts running from the 3rd position after restoring the multi-position running.	1	Start running again from 1st position	For example, if H11-01 = 16 and the servo drive pauses when running to the 2nd position, it starts running from the 1st position after restoring the multi-position running.
Value	Meaning	Description															
0	Complete the remaining distance	For example, if H11-01 = 16 and the servo drive pauses when running to the 2nd position, it starts running from the 3rd position after restoring the multi-position running.															
1	Start running again from 1st position	For example, if H11-01 = 16 and the servo drive pauses when running to the 2nd position, it starts running from the 1st position after restoring the multi-position running.															

H11-03	Parameter name	Time unit			Property	At stop	Control Mode	P
	Setting Range	0 to 1	Unit	-	Effective Time	Immediate	Default	0

It sets the unit of the acceleration/deceleration time and waiting time during the multi-position running.
 Acceleration/Deceleration: time for the servo motor to change from 0 RPM to 1000 RPM or the reverse.
 Waiting time: time interval from ending of the current position reference to starting of the next position reference

Value	Meaning	Description
0	ms	
1	s	

When H11-00 = 3 (Sequential running), H11-03 is invalid, and there is no waiting time between positions.

When H11-00 = 2 (DI switchover), H11-03 is invalid, and the time interval between positions is determined by the delay time command from the host controller.

H11-04	Parameter name	Displacement reference type			Property	At stop	Control Mode	P
	Setting Range	0 to 1	Unit	-	Effective Time	Immediate	Default	0

It sets the displacement reference type when the multi-position function is used.

Displacement reference: sum of position references in a certain time period.

Relative displacement: position increment of the target position relative to the current motor position.

Absolute displacement: position increment of the target position relative to the motor home position.

For example, the displacements of the nth position and mth position are respectively P_n ($P_n > 0$) and P_m ($P_m > 0$):

Value	Meaning	Description
0	Relative displacement reference	<p>mth actual displacement: P_m</p>
1	Absolute displacement reference	<p>mth actual displacement: $P_m - P_n$</p>

When the actual displacement is negative, the motor runs in the reverse direction.

H11-05	Parameter name	Start position of sequential running			Property	At stop	Control Mode	P
	Setting Range	0 to 16	Unit	-	Effective Time	Immediate	Default	0

It sets whether to carry on cyclic running and the start position No. after the first round of running when the multi-position sequential running is enabled (H11-03 = 3).

Value	Meaning	Description
0	Not cyclic	The servo drive runs positions set in H11-01 only once, and stops after the running is completed. Then, the motor becomes in locked state.
1 to 16	1 to 16	Cyclic running is performed. The servo drive starts from the position No. set in H11-05 after the first round of running. $H11-05 \leq H11-01$

Note:

If $H11-05 > H11-01$, H11-05 will be set to 0 forcibly.

H11-12	Parameter name	1st displacement			Property	During running	Control Mode	P
	Setting Range	-1073741824 to 1073741824	Unit	Reference unit	Effective Time	Immediate	Default	10000

It sets the 1st displacement in multi-position (in reference unit).

H11-14	Parameter name	Maximum running speed of 1st displacement			Property	During running	Control Mode	P
	Setting Range	1 to 6000	Unit	RPM	Effective Time	Immediate	Default	200

It sets the maximum running speed of the 1st position in multi-position.

The maximum running speed is the average running speed when the motor is not in acceleration/ deceleration. If H11-12 is too small, the actual motor speed will be smaller than H11-14.

H11-15	Parameter name	Acceleration/Deceleration time of 1st displacement			Property	During running	Control Mode	P
	Setting Range	0 to 65535	Unit	ms(s)	Effective Time	Immediate	Default	10

It sets the time for the servo motor to change from 0 RPM to 1000 RPM or the reverse for the 1st displacement.

Actual time of accelerating to H11-14:

$$t = \frac{(H11-14) \times (H11-15)}{1000}$$

H11-16	Parameter name	Waiting time after 1st displacement			Property	During running	Control Mode	P
	Setting Range	0 to 10000	Unit	ms(s)	Effective Time	Immediate	Default	10

It sets the waiting time from completion of the 1st displacement to start of the next displacement.

For the parameters of 2nd displacement to 16th displacement, refer to the function code table in section 10.4.

Group H12: Multi-Speed Function Parameters

H12-00	Parameter name	Multi-speed running mode			Property	At stop	Control Mode	S
	Setting Range	0 to 2	Unit	-	Effective Time	Immediate	Default	1

It sets the multi-speed reference running mode when the speed reference source is multi-speed (H06-01 = 5, H06-02 = 1/2/3) in speed control mode.

Value	Meaning
0	Stop after running single cycle (number of speeds set in H12-01)
1	Cyclic running (number of speeds set in H12-01)
2	DI switchover

For details, see the descriptions in section 5.3.1.

H12-01	Parameter name	Number of speed reference profile			Property	At stop	Control Mode	S
	Setting Range	1 to 16	Unit	-	Effective Time	Immediate	Default	16

It sets the total number of speed references. Set different speeds, running time, and acceleration/deceleration time (four groups optional) for each speed No.

H12-00 ≠ 2, switchover between speed No. is performed automatically, with the sequence from 1, 2, ..., to H12-01.

H12-00 = 2, set four DIs (hardware DI or VDI) with functions 6 to 9 (FunIN.6:CMD1 to FunIN.9:CMD4) and control the DI logics on the host controller to implement switchover between speed No. The speed No. is a 4-bit binary value, and the relationship between CMD1 to CMD4 and the speed No. is listed in the following table.

FunIN.9	FunIN.8	FunIN.7	FunIN.6	Speed No.
CMD4	CMD3	CMD2	CMD1	
0	0	0	0	1
0	0	0	1	2
.....				
1	1	1	1	16

CMD(n) is 1 when the DI terminal logic is active and 0 when the DI terminal logic is inactive.

H12-02	Parameter name	Time unit			Property	At stop	Control Mode	S
	Setting Range	0 to 1	Unit	-	Effective Time	Immediate	Default	0

It sets the time unit of multi-speed running.

Value	Meaning
0	sec
1	min

H12-03	Parameter name	Acceleration time 1			Property	At stop	Control Mode	S
	Setting Range	0 to 65535	Unit	ms	Effective Time	Immediate	Default	10
H12-04	Parameter name	Deceleration time 1			Property	At stop	Control Mode	S
	Setting Range	0 to 65535	Unit	ms	Effective Time	Immediate	Default	10
H12-05	Parameter name	Acceleration time 2			Property	At stop	Control Mode	S
	Setting Range	0 to 65535	Unit	ms	Effective Time	Immediate	Default	50
H12-06	Parameter name	Deceleration time 2			Property	At stop	Control Mode	S
	Setting Range	0 to 65535	Unit	ms	Effective Time	Immediate	Default	50
H12-07	Parameter name	Acceleration time 3			Property	At stop	Control Mode	S
	Setting Range	0 to 65535	Unit	ms	Effective Time	Immediate	Default	100
H12-08	Parameter name	Deceleration time 3			Property	At stop	Control Mode	S
	Setting Range	0 to 65535	Unit	ms	Effective Time	Immediate	Default	100
H12-09	Parameter name	Acceleration time 4			Property	At stop	Control Mode	S
	Setting Range	0 to 65535	Unit	ms	Effective Time	Immediate	Default	150
H12-10	Parameter name	Deceleration time 4			Property	At stop	Control Mode	S
	Setting Range	0 to 65535	Unit	ms	Effective Time	Immediate	Default	150
<p>Four groups of acceleration/deceleration time can be selected for each speed No.</p> <p>Acceleration time: the time for the servo motor to accelerate from 0 RPM to 1000 RPM.</p> <p>Deceleration time: the time for the servo motor to decelerate from 1000 RPM to 0 RPM.</p>								
H12-20	Parameter name	1st speed reference			Property	At stop	Control Mode	S
	Setting Range	-6000 to 6000	Unit	RPM	Effective Time	Immediate	Default	0

H12-21	Parameter name	Running time of 1st speed reference			Property	At stop	Control Mode	S
	Setting Range	0 to 6553.5	Unit	s(min)	Effective Time	Immediate	Default	5.0

It sets the running time of the 1st speed reference.

Running time = Speed change time from previous speed reference switched over to the current speed reference + Average running time

If the running time is 0, the servo drive automatically ignores this speed reference.

If H12-00 = 2 and the speed No. determined by the DI does not change, the servo drive continues running at this speed, without being affected by the running time.

H12-22	Parameter name	Acceleration/deceleration time of 1st speed reference			Property	At stop	Control Mode	S
	Setting Range	0 to 4	Unit	-	Effective Time	Immediate	Default	0

It sets the acceleration/deceleration time of the 1st speed reference.

Value	Meaning	Description
0	No acceleration/deceleration time	Acceleration time: 0 Deceleration time: 0
1	Acceleration/Deceleration time 1	Acceleration time: H12-03 Deceleration time: H12-04
2	Acceleration/Deceleration time 2	Acceleration time: H12-05 Deceleration time: H12-06
3	Acceleration/Deceleration time 3	Acceleration time: H12-07 Deceleration time: H12-08
4	Acceleration/Deceleration time 4	Acceleration time: H12-09 Deceleration time: H12-10

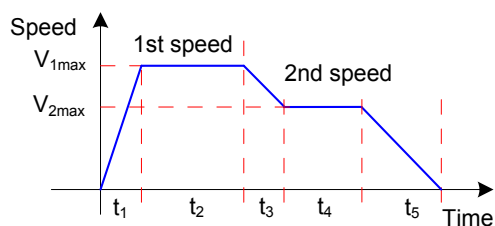

V1max, V2max: 1st and 2nd speeds

t1: actual acceleration/deceleration time of 1st speed

t3, t5: acceleration/deceleration time of 2nd speed

Running time of a certain speed = Speed change time from previous speed reference switched over to the current speed reference + Average running time

For example, the running time of the 1st speed and 2nd speed is respectively $t_1 + t_2$ and $t_3 + t_4$.

Do not set the running time to 0; otherwise, the servo drive automatically ignores this speed reference and directly runs the next speed No.

$$t_1 = \frac{V_1}{1000} \times \text{Accel. time of this speed}$$

$$t_3 = \frac{|V_2 - V_1|}{1000} \times \text{Accel. Time of 2nd speed}$$

For the parameters of 2nd speed reference to 16th speed reference, refer to the function code table in section 10.4.

Group H17: VDI/VDO Parameters

H17-00	Parameter name	VDI1 function selection			Property	During running	Control Mode	-
	Setting Range	0 to 37	Unit	-	Effective Time	Upon stop	Default	0

It sets the functions of virtual digital input 1 (VDI1). Use the VDI according to the following procedure:

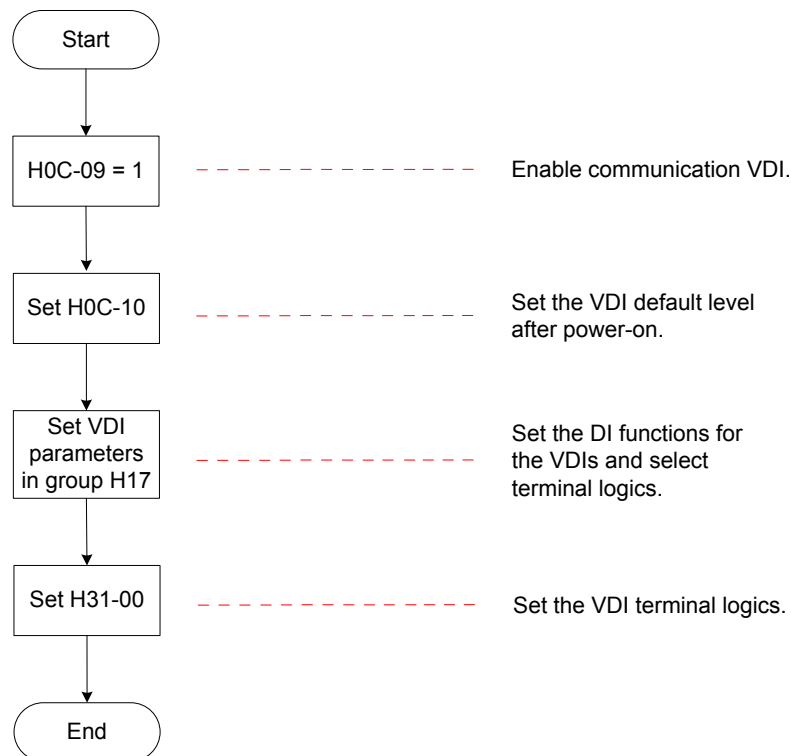

For the DI functions, see "DI/DO Function Definitions".

Note:

When the forced DI is used, VDI1 to VDI9 logics are determined by the forced DI, that is, H0D-18.

Value	DI Function	Value	DI Function
0	No function	19	JOGCMD- (Reverse jog)
1	S-ON (Servo ON)	20	PosStep (Step reference)
2	ALM-RST (Fault and warning reset)	21	HX1 (Handwheel multiplying factor signal 1)
3	GAIN-SEL (Gain switchover)	22	HX2 (Handwheel multiplying factor signal 2)
4	CMD-SEL (Main/Auxiliary reference switchover)	23	HX_EN (Handwheel signal)
5	DIR-SEL (Multi-reference direction)	24	GEAR_SEL (Electronic gear ratio switchover)
6	CMD1 (Multi-reference switchover 1)	25	ToqDirSel (Torque reference direction)
7	CMD2 (Multi-reference switchover 2)	26	SpdDirSel (Speed reference direction)
8	CMD3 (Multi-reference switchover 3)	27	PosDirSel (Position reference direction)
9	CMD4 (Multi-reference switchover 4)	28	PosInSen (Multi-position reference enable)
10	M1-SEL (Mode switchover 1)	29	XintFree (Position change on fly unlock)
11	M2-SEL (Mode switchover 2)	30	None
12	ZCLAMP (Zero speed clamp)	31	HomeSwitch (Home switch)
13	INHIBIT (Position reference inhibited)	32	HomingStart (Homing function)
14	P-OT (Forward limit switch)	33	XintInhibit (Position change on fly inhibited)
15	N-OT (Reverse limit switch)	34	EmergencyStop (Emergency stop)
16	P-CL (External positive torque limit)	35	ClrPosErr (Position deviation cleared)
17	N-CL (External negative torque limit)	36	V_LmtSel (Internal speed limit source)
18	JOGCMD+ (Forward jog)	37	PulseInhibit (Pulse input inhibited)

Set H17-00 to a value within the preceding table.

H31-00 is not displayed on the keypad and can be set only via communication.

Each DI must be allocated with a unique function. Otherwise, Er.130 will occur (different DIs allocated with the same function).

H17-01	Parameter name	VDI1 logic selection			Property	During running	Control Mode	-
	Setting Range	0 to 1	Unit	-	Effective Time	Upon stop	Default	0

It sets the level logic of VD1 for enabling the VDI1 function .

Value	VDI1 Logic when Function Valid	H31-00 Signal
0	Valid when logic is 1	
1	Valid when logic changes from 0 to 1	

The VDI terminal logic is determined by H0C-01 upon first-time power-on and then determined by H31-00.

H0C-10 value displayed on the keypad is decimal, and H31-00 is not displayed on the keypad. In the converted binary value of H0C-10 (H31-00), bit(n) = 1 indicates that terminal VDI(n+1) logic is 1, and bit(n) = 0 indicates that terminal VDI(n+1) logic is 0.

For the parameters of VDI2 to VDI16, refer to the function code table in section 10.4.

H17-32	Parameter name	VDO virtual level			Property	Display	Control Mode	-
	Setting Range	-	Unit	-	Effective Time	-	Default	-

It displays the VDO virtual levels.

H0C-12 (H17-32) value displayed on the keypad is hexadecimal. In the converted binary value of H0C-12 (H17-32), bit(n) = 1 indicates that terminal VDO(n+1) logic is 1, and bit(n) = 0 indicates that terminal VDO(n+1) logic is 0.

It is recommended that the VDO logic levels are opposite to H0C-12.

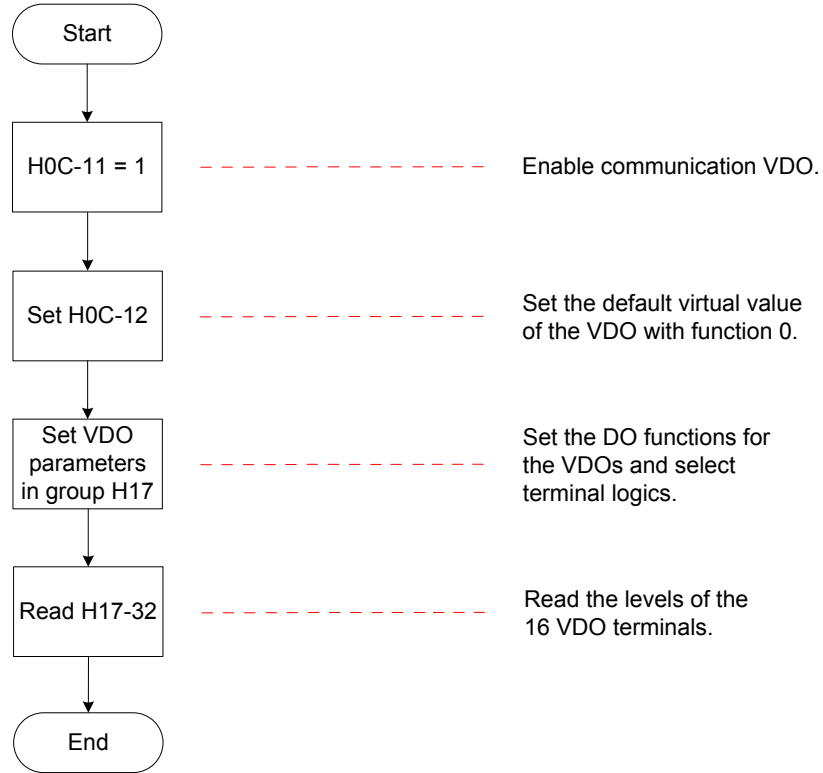

H17-33	Parameter name	VDO1 function selection			Property	During running	Control Mode	-
	Setting Range	0 to 19	Unit	-	Effective Time	Upon stop	Default	0

It sets the VDO1 function.

For the DO functions, see "DI/DO Function Definitions".

Value	DO Function
0	No function
1	S-RDY (Servo ready)
2	TGON (Motor rotation output)
3	ZERO (Zero speed signal)
4	V-CMP (Speed consistent)
5	COIN (Positioning completed)
6	NEAR (Positioning near)
7	C-LT (Torque limit)
8	V-LT (Speed limit)
9	BK (Brake output)
10	WARN (Warning output)
11	ALM (Fault output)
12	ALMO1 (3-digit fault code output)
13	ALMO2 (3-digit fault code output)
14	ALMO3 (3-digit fault code output)
15	Xintcoin (Position change on fly completed)
16	HomeAttain (Home attaining output)
17	ElecHomeAttain (Electrical home attaining output)
18	ToqReach (Torque reached)
19	V-Arr (Speed reached)

Set H17-33 to a value within the preceding table.

Different VDOs can be allocated with the same function.

7

H17-34	Parameter name	VDO1 logic selection			Property	During running	Control Mode	-
	Setting Range	0 to 1	Unit	-	Effective Time	Upon stop	Default	0

Value	VDO1 Logic	Description
0	Output 1 when function valid	
1	Output 0 when function valid	

For the parameters of VDO2 to VDO16, refer to the function code table in section 10.4.

Group H30: Servo Variables Read by Communication

H30-00	Parameter name	Servo state read by communication			Property	Read-only	Control Mode	PST
	Setting Range	-	Unit	-	Effective Time	-	Default	-

It reads the servo running state via communication.

H30-00 value is hexadecimal, and is not displayed on the keypad. It is read as binary, and each bit of the binary is defined as follows:

Bit	Servo State	Description
bit0	Servo ready	It determines whether the servo main circuit DC bus voltage is ready and the servo drive is ready for running. 0: Servo not ready 1: Servo ready
bit1 to bit11	Reserved	-
bit12 to bit13	Servo running state	It determines the servo running state. 00: Servo not ready (main circuit DC bus voltage not set up correctly) 01: Servo ready (main circuit DC bus voltage set up correctly, servo drive is ready for running) 10: Servo running (S-ON active) 11: Servo fault (a No. 1 or No. 2 fault occurs)
bit14 to bit15	Reserved	-

H30-01	Parameter name	DO function state 1 read via communication			Property	Read-only	Control Mode	PST
	Setting Range	-	Unit	-	Effective Time	-	Default	-

It reads DO function 1 to DO function 16 via communication.

H30-01 value is hexadecimal, and is not displayed on the keypad. It is read as binary via communication.

Bit	DO Function	Description
bit0	DO function 1 (FunOUT.1:S-RDY, servo ready)	0: Servo not ready 1: Servo drive ready
.....		
bit15	DO function 16 (FunOUT.16: HomeAttain, homing output)	0: Homing completed 1: Homing completed

Note: If no DO or VDO is allocated with function 9 (FunOUT.9: BK, brake output), FunOUT.9 in H30-01 is invalid.

H30-02	Parameter name	DO function state 2 read via communication			Property	Read-only	Control Mode	PST
	Setting Range	-	Unit	-	Effective Time	-	Default	-

It reads DO function 17 to DO function 20 via communication.
 H3-02 value is hexadecimal, and is not displayed on the keypad. It is read as binary via communication.

Bit	DO Function	Description
bit0	DO function 17 (FunOUT.17: ElecHomeAttain, electric homing output)	0: Electric homing not completed 1: Electric homing completed
.....		
bit4 to bit15	Reserved	

H30-03	Parameter name	Input pulse sampling read via communication			Property	At display	Control Mode	PST
	Setting Range	-	Unit	-	Effective Time	-	Default	-

It displays the pulses at the pulse input terminal read via communication within a single control period when the position reference source is pulse input (H05-00 = 1) or handwheel input (a certain DI is allocated with FunIN.23, and the corresponding DI logic is active). This parameter is irrelevant to the servo running mode and running status.

Group H31: Servo Variables Set via Communication

H31-00	Parameter name	VDI virtual level set via communication			Property	During running	Control Mode	PST
	Setting Range	0 to 65535	Unit	-	Effective Time	Immediate	Default	0

It sets the DI function levels of VDI1 to VDI16.

H31-00 value is decimal, and is not displayed on the keypad. It can be set only via communication.

Use the VDI according to the following procedure:

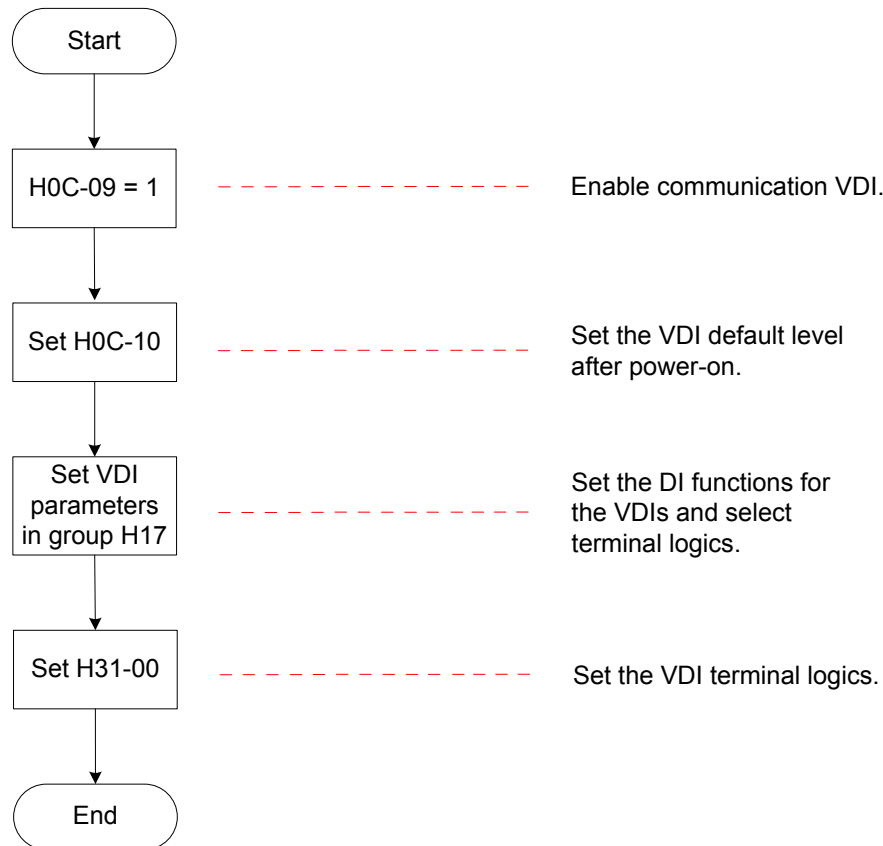

The VDI terminal logic is determined by H0C-01 upon first-time power-on and then determined by H31-00.

H0C-10 value displayed on the keypad is decimal, and H31-00 is not displayed on the keypad. In the converted binary value of H0C-10 (H31-00), bit(n) = 1 indicates that terminal VDI(n+1) logic is 1, and bit(n) = 0 indicates that terminal VDI(n+1) logic is 0.

For the setting of the VDI functions and logics, see the descriptions of group H17.

H31-04	Parameter name	DO state set via communication			Property	During running	Control Mode	PST
	Setting Range	0 to 31	Unit	-	Effective Time	Immediate	Default	0

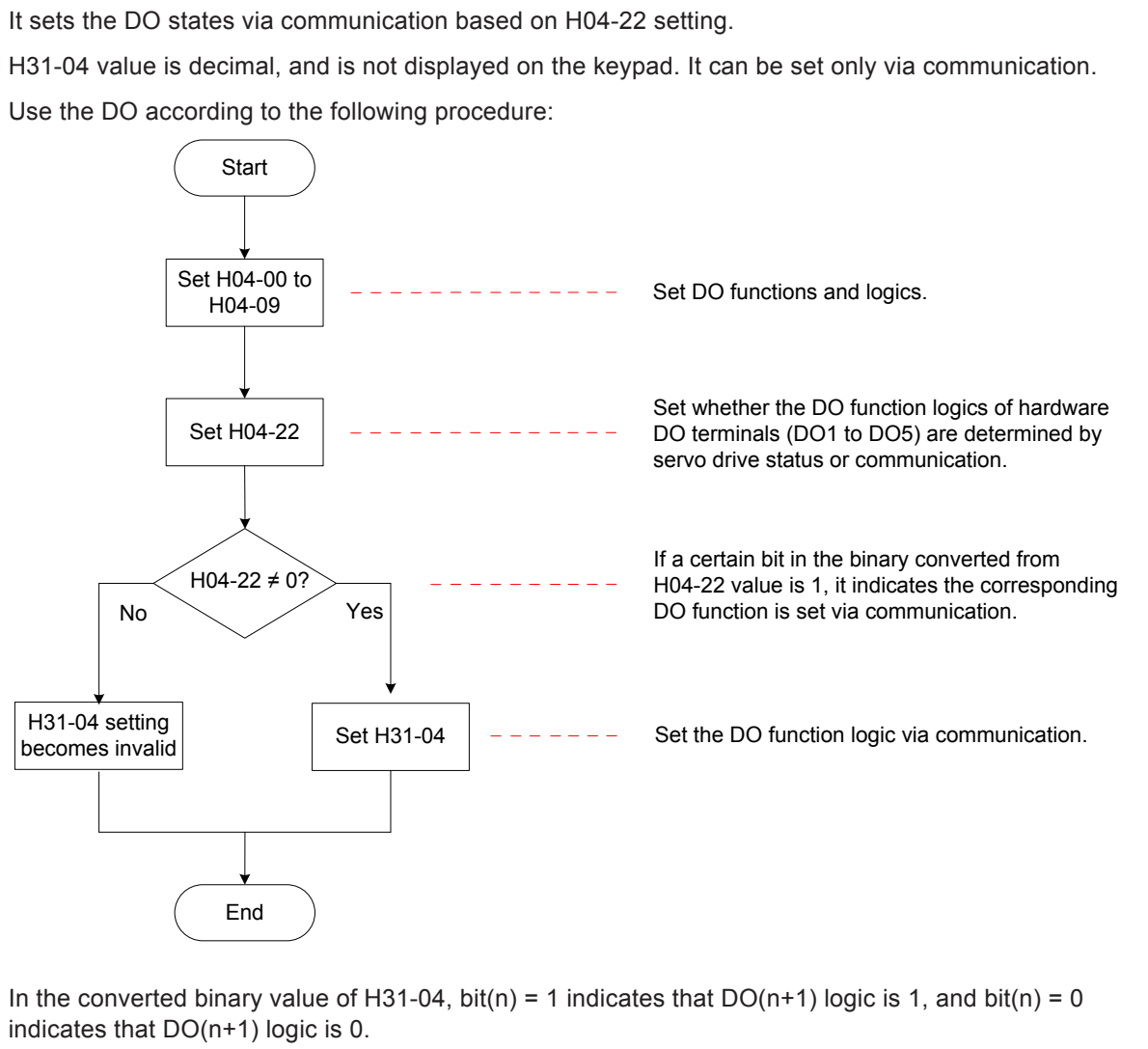

H31-09	Parameter name	Speed reference set via communication			Property	During running	Control Mode	S
	Setting Range	-6000.000 to 6000.000	Unit	RPM	Effective Time	Immediate	Default	0

It sets the speed reference (in unit of 0.001 RPM) when the speed reference source is communication setting in speed control mode.

H31-09 value is 32-bit data, and is not displayed on the keypad. It can be set only via communication.

7

H31-11	Parameter name	Torque reference set via communication			Property	During running	Control Mode	T
	Setting Range	-100.000 to 100.000	Unit	%	Effective Time	Immediate	Default	0

It sets the torque reference (in unit of 0.001%) when the torque reference source is communication setting in torque control mode.

The value 100.000% corresponds to the rated motor torque.

H31-11 value is 32-bit data, and is not displayed on the keypad. It can be set only via communication.



8 Troubleshooting

8.1 During Startup	412
8.1.1 Position Control.....	412
8.1.2 Speed Control	417
8.1.3 Torque Control.....	420
8.2 During Running	422
8.2.1 Fault and Warning Code List.....	422
8.2.2 Troubleshooting of Faults	426
8.2.3 Troubleshooting of Warnings.....	447
8.2.4 Internal Faults	454

Chapter 8 Troubleshooting

8.1 During Startup

8.1.1 Position Control

During Startup	Fault Symptom	Cause	Confirming Methods
Connect control power L1C/L2C and main power L1/L2 and R/S/T.	The LED display is not on or does not display "rdy".	1. The control power voltage is abnormal.	After disconnecting CN1, CN2, CN3 and CN4, the fault persists. Measure AC voltage between L1C and L2C.
		2. The main power voltage is abnormal.	For single-phase 220 V model, measure AC voltage between L1 and L2. When DC bus voltage amplitude (voltage between P _⊕ and ⊖) is lower than 200 V, "nrd" is displayed. For three-phase 220/380 V model, measure AC voltage between R, S and T. When DC bus voltage amplitude (voltage between P _⊕ and ⊖) is lower than 460V, "nrd" is displayed.
		3. The program burning terminal is shorted.	Check whether the program burning terminal is shorted.
		4. The servo drive is faulty.	-
	The operation panel displays "Er. xxx".	Refer to section 8.2 to remove the fault.	
After the preceding causes are removed, the operation panel should display "rdy".			

During Startup	Fault Symptom	Cause	Confirming Methods
Set the S-ON signal (S-ON) to ON.	The operation panel displays "Er. xxx".	Refer to section 8.2 to remove the fault.	
	Shaft of the servo motor is in free running status.	1. The S-ON signal is invalid.	<p>Set operation panel to servo status display and view whether the operation panel displays "rdy" rather than "run".</p> <p>Check whether any parameter in groups H03 and H17 is set for FunIN1(S-ON). If yes, check that the corresponding DI is set to ON. If not, allocate the function and set the corresponding DI to ON. See group H03 in Chapter 7 for details on setting of input terminal parameters.</p> <p>If a parameter in group H03 has been set for FunIN1(S-ON) and corresponding DI is ON, but the operation panel still displays "rdy". In this case, check whether the DI terminal is connected correctly by referring to Chapter 3.</p>
		2. Selection of control mode is incorrect.	Check whether H02-00 is set to 1. If it is set to 2 (torque mode), motor shaft must be in free running status because default torque reference is 0.
	After the preceding causes are removed, the operation panel should display "run".		

During Startup	Fault Symptom	Cause	Confirming Methods
Input position reference.	Servo motor does not rotate.	Input reference pulse counter (H0B-13) is 0.	<p>High/low-speed pulse input terminal is wired incorrectly.</p> <p>When H05-00 = 0 (pulse is main position reference source), check whether high/low-speed pulse input terminal is wired correctly by referring to Chapter 3 Wiring. Meanwhile, check whether the setting of H05-01(reference pulse selection) is matched.</p> <p>Position reference is not input.</p> <ol style="list-style-type: none"> 1. Check whether FunIN.13: INHIBIT (pulse input forbidden) or FunIN.37: PulseInhibit (pulse forbidden) is used. 2. When H05-00 = 0 (pulse is main position reference source), host computer or other pulse generator does not output pulses. Check whether there are pulses into high/low-speed pulse input terminal. Please refer to Chapter 3. 3. When H05-00 = 1 (step reference is main position reference source), check whether H05-05 (step amount) is 0. If not, check whether FunIN.20: PosStep (DI position step reference) has been allocated and whether logic of corresponding terminal is valid. <p>When H05-00 = 2 (multi-position reference is main position reference source), check whether parameters in group H11 are set correctly. If yes, , check whether FunIN.28: PosInSen (internal multi-position enable) has been allocated and whether logic of corresponding terminal is valid.</p> <p>5. If position change on fly is used, check whether H05-29 (position change on fly unlock) is set to 1(enabled). If yes, check whether FunIN.29: XintFree (position change on fly unlocked) is used.</p>
	Servo motor rotates in reverse direction.	Input reference pulse counter (H0B-13) is negative.	<p>When H05-00 = 0 (pulse is main position reference source), check whether the setting of H05-15 (reference pulse form) is consistent with actual pulse input. If not, it indicates that H05-15 is set incorrectly or terminal wiring is incorrect.</p> <p>When H05-00 = 1 (step reference is main position reference source), check whether H05-05 (step amount) is positive or negative.</p> <p>When H05-00 = 2 (multi-position reference is main position reference source), check whether each displacement is positive or negative.</p> <p>When H05-00 = 2 (multi-position reference is main position reference source), check whether each displacement is positive or negative.</p> <p>Check whether H02-02 (rotation direction selection) is set correctly.</p>
Servo motor can rotate after preceding fault is removed.			

During Startup	Fault Symptom	Cause	Confirming Methods
Servo motor jitters at low speed.	Motor speed is not steady.	The gain is set improperly.	Perform automatic gain tuning in accordance with section 6.3.
	Motor shaft vibrates left and right.	The load inertia ratio (H08-15) is too large.	If servo motor can run safely, perform inertia auto-tuning in accordance with section 6.2 and perform automatic gain tuning in accordance with section 6.3.
After preceding causes are removed, servo motor can operate normally.			
Servo system runs normally.	Positioning inaccurate	Unsatisfactory position deviation is generated.	Confirm input reference pulse counter (H0B-13), feedback pulse counter (H0B-17) and mechanical stop position according to the following steps.

The procedure of removing cause of positioning inaccurate is as follows:

Figure 8-1 Positioning control schematic diagram

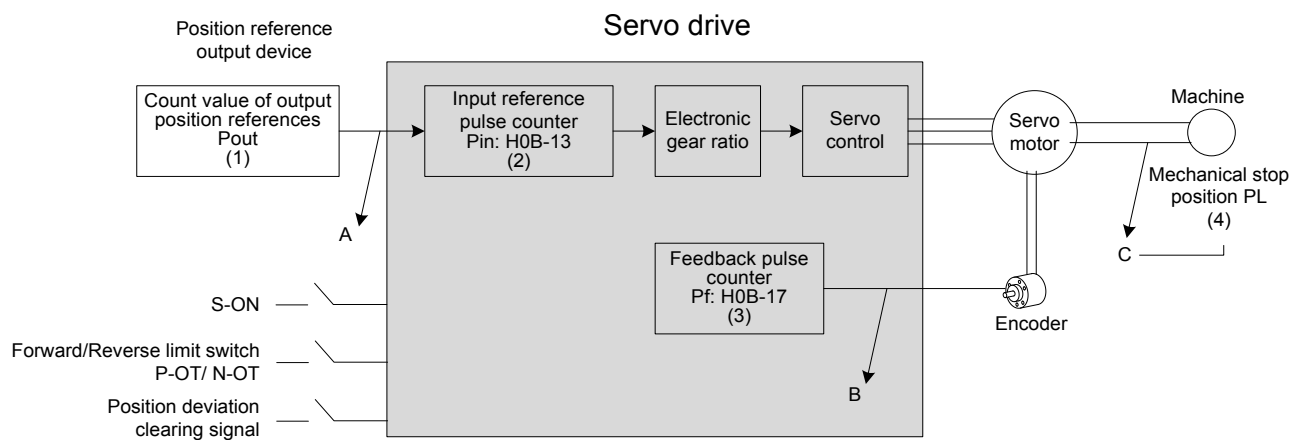

When positioning is inaccurate, check the four signals in Figure 8-1.

- (1) Count value of output position references Pout of the position reference output device (host computer or internal parameters of the drive)
- (2) Input reference pulse counter Pin received by the servo drive, corresponding to H0B-13
- (3) Accumulative feedback pulses from the encoder, corresponding to H0B-17
- (4) Mechanical stop position PL

There are three causes resulting in inaccurate positioning, corresponding to A, B and C in Figure 8-1.

A: 1) Counting of input position reference is incorrect because cable connecting host computer and the servo drive is affected by noise.

2) Input position reference is interrupted during motor running. Cause: Servo ON signal (S-ON) is set to OFF, the forward/reverse limit switch signal (P-OT or N-OT) is ON and the position deviation clearing signal (ClrPosErr) is ON.

B: The encoder feedback position signal is wrong (signal suffers interference).

C: Mechanical position slides between machine and servo motor.

In ideal state(no position deviation), the following relationships exist.

$P_{out} = P_{in}$, count value of output position references = Input position reference counter

$\text{Pin} \times \text{electronic gear ratio} = \text{Pf}$, Input position reference counter \times electronic gear ratio = accumulative feedback pulses

$\text{Pf} \times \Delta L = \text{PL}$, accumulative feedback pulses \times corresponding load displacement of one position reference = mechanical stop position

When inaccurate positioning occurs, perform the following checks:

- $\text{Pout} \neq \text{Pin}$

Cause: A

To solve issue A, do as follows:

Check whether the pulse input terminal (low-speed or high-speed pulse input terminal, refer to Chapter 3) is connected with shielded twisted pair (STP) cable.

If open-collector input of low-speed pulse input terminal is used, change it into differential input.

Separate wirings of the pulse input terminal from wirings of main circuits (L1C/L2C, R/ S/ T, U/ V/ W).

If low-speed pulse input terminal is selected, increase filter time of low-speed pulse input pin (H0A-24). If high-speed pulse input terminal is selected, increase filter time of high-speed pulse input pin (H0A-30).

- $\text{Pin} \times \text{electronic gear ratio} \neq \text{Pf}$:

Cause: B

To solve issue B, do as follows:

Check whether a fault occurs during running, which results in that not all references are executed but servo drive stops.

If the cause is that the position deviation cleared signal (ClrPosErr) is valid, check whether the position deviation clearing mode (H05-16) is reasonable.

- $\text{Pf} \times \Delta L \neq \text{PL}$

Cause: C

To solve issue C, do as follows:

Check mechanical connections and find the sliding position.

8.1.2 Speed Control

During Startup	Fault Phenomenon	Cause	Confirming Methods
Connect control power L1C/L2C and main power L1/L2 and R/S/T.	The LED display is not on or does not display "rdy".	1. Control power voltage is abnormal.	After disconnecting CN1, CN2, CN3 and CN4, the fault persists. Measure AC voltage between L1C and L2C.
		2. Main power voltage is abnormal.	For single-phase 220 V mode, measure AC voltage between L1 and L2. When DC bus voltage amplitude (voltage between P _⊕ and ⊖) is lower than 200 V, "nrd" is displayed. For three-phase 220/380 V model, measure AC voltage between R, S and T. When DC bus voltage amplitude (voltage between P _⊕ and ⊖) is lower than 460V, "nrd" is displayed.
		3. The program burning terminal is shorted.	Check whether the program burning terminal is shorted.
		4. The servo drive is faulty.	-
	The operation panel displays "Er.xxx".	Refer to section 8.2 to remove the fault.	
After the preceding causes are removed, the operation panel should display "rdy".			
Set the S-ON signal (S-ON) to ON.	The operation panel displays "Er.xxx".	Refer to section 8.2 to remove the fault.	
	Shaft of the servo motor is in free running status.	1. The S-ON signal is invalid.	Set operation panel to servo status display and view whether the operation panel displays "rdy" rather than "run". Check whether any parameter in groups H03 and H17 is set for FunIN1(S-ON). If yes, check that the corresponding DI is set to ON. If not, allocate the function and set the corresponding DI to ON. See group H03 in Chapter 7 for details on setting of input terminal parameters. If a parameter in group H03 has been set for FunIN1(S-ON) and logic of corresponding DI is logic, but the operation panel still displays "rdy". In this case, check whether the DI terminal is connected correctly by referring to Chapter 3.
		2. Selection of control mode is incorrect.	Check whether H02-00 is set to 0. If it is set to 2 (torque mode), motor shaft must be in free running status because default torque reference is 0.
After the preceding causes are removed, the operation panel should display "run".			

During Startup	Fault Phenomenon	Cause	Confirming Methods
Input speed reference	Servo motor does not rotate or the motor speed is abnormal.	Speed reference (H0B-01) is 0.	<p>AI wiring is incorrect.</p> <p>When speed reference is input from AI, check whether the analog input channel is selected correctly and check whether the selected AI terminal is wired correctly by referring to Chapter 3.</p> <p>Speed reference selection is incorrect.</p> <p>Check whether H06-02 (speed reference selection) is set correctly.</p> <p>Speed reference is not input or is abnormal.</p> <ol style="list-style-type: none"> 1. When AI is selected to input speed reference, check whether AI related parameters in group H03 are set correctly first. Then check whether input voltage is correct by observing voltage on oscilloscope or viewing AI sampling voltage in H0B-21 or H0B-22. 2. When digital setting is used to set speed reference, check whether H06-03 (keypad setting value of speed reference) is set correctly. 3. When multi-speed is used to set speed reference, check whether the parameters in group H12 are set correctly. 4. When serial comms. is used to set speed reference, check whether H31-09 (speed reference set via communication) is set correctly. 5. When jog speed reference is used to set speed reference, check whether H06-04 (jog speed setting value) is set correctly, whether DI functions FunIN.18: JOGCMD+ (forward jog) and FunIN.19: JOGCMD- (reverse jog) have been allocated and whether logic of corresponding DIs is valid. 6. Check whether H06-05 (acceleration ramp time constant of speed reference) and H06-06 (deceleration ramp time constant of speed reference) are set correctly. 7. Check whether the DI function FunIN.12: ZCLAMP (zero speed clamp function) is misallocated and whether valid logic of corresponding DI is corrected.

During Startup	Fault Phenomenon	Cause	Confirming Methods
Input speed reference	Servo motor rotates in reverse direction.	Speed reference (H0B-01) is negative.	<p>1. When AI is selected to input speed reference, check whether polarity of input signal is reverse.</p> <p>2. When digital setting is used to set speed reference, check whether H06-03 (keypad setting value of speed reference) is smaller than 0.</p> <p>3. When multi-speed is used to set speed reference, check whether speed references in group H12 are positive or negative.</p> <p>4. When serial comms. is used to set speed reference, check whether H31-09 (speed reference set via communication) is smaller than 0.</p> <p>When jog speed reference is used to set speed reference, check value of H06-04 (jog speed setting value). Then check whether effective logic of DI functions FunIN.18: JOGCMD+ (forward jog) and FunIN.19: JOGCMD- (reverse jog) matches the predicted rotating direction.</p> <p>Check whether DI function FunIN.26: SpdDirSel (speed reference direction) has been allocated and whether logic of corresponding DI is valid.</p> <p>Check whether H02-02 (rotation direction selection) is set correctly.</p>
	Servo motor can rotate after preceding fault is removed.		
Servo motor jitters at low speed.	Motor speed is not steady.	The gain is set unreasonably.	Perform automatic gain tuning in section 6.3.
	Motor shaft vibrates left and right.	The load inertia ratio (H08-15) is too large.	If servo motor can run safely, perform inertia auto-tuning in accordance with section 6.2 and perform automatic gain tuning in accordance with section 6.3.

8.1.3 Torque Control

During Startup	Fault Phenomenon	Cause	Confirming Methods
Connect control power L1C/L2C and main power L1/L2 and R/S/T.	The LED display is not on or does not display Rdy.	1. The control power voltage is abnormal.	After disconnecting CN1, CN2, CN3 and CN4, the fault persists. Measure AC voltage between L1C and L2C.
		2. The main power voltage is abnormal.	For single-phase 220 V mode, measure AC voltage between L1 and L2. When DC bus voltage amplitude (voltage between P _⊕ and ⊖) is lower than 200 V, "nrd" is displayed. For three-phase 220/380 V model, measure AC voltage between R, S and T. When DC bus voltage amplitude (voltage between P _⊕ and ⊖) is lower than 460V, "nrd" is displayed.
		3. The program burning terminal is shorted.	Check whether the program burning terminal is shorted.
		4. The servo drive is faulty.	-
	The operation panel displays "Er. xxx".	Refer to section 8.2 to remove the fault.	
After the preceding causes are removed, the operation panel should display "rdy".			
Set the S-ON signal (S-ON) to ON.	The operation panel displays "Er. xxx".	Refer to section 8.2 to remove the fault.	
	Shaft of the servo motor is in free running status.	1. The S-ON signal is invalid.	Set operation panel to servo status display and view whether the operation panel displays "rdy" rather than "run". Check whether any parameter in groups H03 and H17 is set for FunIN1(S-ON). If yes, check that the corresponding DI is set to ON. If not, allocate the function and set the corresponding DI to ON. See group H03 in Chapter 7 for details on setting of input terminal parameters. If a parameter in group H03 has been set for FunIN1(S-ON) and logic of corresponding DI is logic, but the operation panel still displays "rdy". In this case, check whether the DI terminal is connected correctly by referring to Chapter 3.
After the preceding causes are removed, the operation panel should display "run".			

During Startup	Fault Phenomenon	Cause	Confirming Methods
Input torque reference	Servo motor does not rotate.	Internal torque reference (H0B-02) is 0.	<p>AI wiring is incorrect.</p> <p>When AI is selected to input torque reference, check whether polarity of input signal is reverse.</p> <p>Selection of torque reference is incorrect.</p> <p>Check whether H07-02 (torque reference source) is set correctly.</p> <p>Torque reference is not input.</p> <ol style="list-style-type: none"> 1. When AI is selected to input torque reference, check whether AI related parameters in group H03 are set correctly first. Then check whether input voltage is correct by observing voltage on oscilloscope or reading the value of H0B-21 or H0B-22. 2. When digital setting is used to set torque reference, check whether H07-03 (keypad setting value of torque reference) is set correctly. 3. When serial comms. is used to set torque reference, check whether H31-11 (torque reference set via communication) is set correctly.
	Servo motor rotates in reverse direction.	Internal torque reference (H0B-02) is negative.	<ol style="list-style-type: none"> 1. When AI is selected to input torque reference, check whether polarity of external voltage input signal is reverse. You can confirm it by using an oscilloscope or viewing H0B-21 or H0B-22. 2. When digital setting is used to set torque reference, check whether H07-03 (keypad setting value of torque reference) is smaller than 0. 3. When serial comms. is used to set torque reference, check whether H31-11 (torque reference set via communication) is smaller than 0. 4. Check whether DI function FunIN.25: ToqDirSel (torque reference direction) has been allocated and whether logic of corresponding DI is valid. 5. Check whether H02-02 (rotation direction selection) is set correctly.
Servo motor can rotate after preceding fault is removed.			
Servo motor jitters at low speed.	Motor speed is not steady.	The gain is set unreasonably.	Perform automatic gain tuning in section 6.3.
	Motor shaft vibrates left and right.	The load inertia ratio (H08-15) is too large.	If servo motor can run safely, perform inertia auto-tuning in accordance with section 6.2 and perform automatic gain tuning in accordance with section 6.3.

8.2 During Running

8.2.1 Fault and Warning Code List

1. Fault and Warning Grading

Faults and alarms are graded into the following four levels based on degree of severity:

- NO.1 non-resettable fault
- NO.1 resettable fault
- NO.2 resettable fault
- NO.3 resettable warning

"Resettable" means that the operating panel stops display of fault/warning once the reset signal is input.

To reset a fault/warning, set H0D-01 = 1 (fault reset enabled) or set DI terminal allocated with function FunIN.2 (ALM-RST) to ON.

To reset NO.1 fault and NO.2 fault, set S-ON to OFF and then set H0D-01 = 1 or set the DI terminal allocated with function FunIN.2 (ALM-RST) to ON.

To reset NO.3 warning, set H0D-01 = 1 or set the DI terminal allocated with the function FunIN.2 (ALM-RST) to ON.



CAUTION

Some faults/warnings can only be reset after issue is solved. Parameter modification will not become effective until you re-connect control power (L1C, L2C) or stop servo drive. In scenario where you need to stop servo drive, set S-ON to OFF. Once modification becomes effective, the servo drive can run normally.

Relevant parameters:

Function Code	Parameter Name	Setting Range	Function	Property	Effective Time	Default
H0D-01	Fault reset	0: No operation 1: Enabled	When a resettable fault/warning occurs, set H0D-01 to 1 to reset it. When resetting is completed, immediately set H0D-01 to 0.	At stop	Immediate	0

Relevant function No.:

No.	Function Symbol	Function Name	Description
FunIN.2	ALM-RST	Fault/Warning reset signal	<p>This DI function is edge valid rather than high/low level valid. The servo drive can continue to operate after fault/warning reset.</p> <p>When this function is allocated to a low-speed DI and logic of the ID is level valid, the servo drive will forcibly changes it to edge logic. The valid level change must last for more than 3 ms; otherwise, the fault reset function becomes invalid.</p> <p>Do not allocate this function to high-speed DI. Otherwise, fault/warning reset will be invalid.</p> <p>Invalid: not reset fault/warning Valid: reset fault/warning</p>

2. Fault and Warning Record

Servo drive has the function of recording faults and warnings. It can record names of recent ten faults and warnings and drive status parameters at fault/warning occurrence. If a fault or a warning occurs five times recently, servo drive records it only once.

After fault/warning reset is successful, servo drive still records the fault/warning. To clear record, use system initialization (H02-31 = 1 or 2).

You can select fault/warning record No. in H0B-33, view corresponding fault/warning code in H0B-34 and view drive status parameters in H0B-35 to H0B-42. For details of these parameters, refer to Chapter 3. If no fault occurs, the operation panel displays "Er.000" in H0B-34.

When you view fault/warning code in H0B-34, the operation panel displays "Er.xxx", where "xxx" is fault/warning code. When you read H0B-34 through Inovance servo commissioning software or communication, the decimal data must be converted to hexadecimal equivalent. The following table gives examples of data conversion.

Er.xxx	H0B-34 (Decimal)	H0B-34 (HEX)	Description
Er.101	257	0101	0: NO.1 non-resettable fault 101: Fault code
Er.130	8496	2130	2: NO.1 resettable fault 130: Fault code
Er.121	24865	6121	6: NO.2 resettable fault 121: Fault code
Er.110	57616	E110	E: NO.3 resettable warning 110: Warning code

3. Fault/Warning Code Output

Servo drive can output current highest-level fault/warning code.

To implement fault/warning output, set three DO terminals for FunOUT.12: ALMO1 (3-digit fault code output), FunOUT.13: ALMO2 (3-digit fault code output) and FunOUT.14: ALMO3 (3-digit fault code output). When different faults/warnings occur, level of the three DOs changes.

a. NO.1 non-resettable fault

Display	Fault Name	Type	Resettable	DO Output		
				AL3	AL2	AL1
Er.101	Groups H02 and above parameters abnormal	NO.1	No	1	1	1
Er.102	Programmable logic configuration fault	NO.1	No	1	1	1
Er.104	Programmable logic interruption	NO.1	No	1	1	1
Er.105	Internal program abnormal	NO.1	No	1	1	1
Er.108	Parameter storage fault	NO.1	No	1	1	1
Er.111	Internal fault	NO.1	No	1	1	1
Er.120	Product model matching fault	NO.1	No	1	1	1
Er.122	Product matching fault in absolute position mode	NO.1	No	1	1	1
Er.136	Data check error or no parameter stored in the motor ROM	NO.1	No	1	1	1
Er.200	Overcurrent 1	NO.1	No	1	1	0
Er.201	Overcurrent 2	NO.1	No	1	1	0
Er.208	FPGA system sampling operation timeout	NO.1	No	1	1	0
Er.210	Output short-circuit to ground	NO.1	No	1	1	0
Er.220	Phase sequence incorrect	NO.1	No	1	1	0
Er.234	Runaway	NO.1	No	1	1	0
Er.430	Control power undervoltage	NO.1	No	0	1	1
Er.740	Encoder interference	NO.1	No	1	1	1
Er.834	AD sampling overvoltage	NO.1	No	1	1	1
Er.835	High-accuracy AD sampling fault	NO.1	No	1	1	1
Er.A33	Encoder data abnormal	NO.1	No	0	1	0
Er.A34	Encoder communication check abnormal	NO.1	No	0	1	0
Er.A35	Z signal lost	NO.1	No	0	1	0

Note

1 indicates valid and 0 indicates invalid. They do not indicate high/low level of DO terminals.

b. NO.1 resettable fault

Display	Fault Name	Type	Resettable	DO Output		
				AL3	AL2	AL1
Er.130	Different DIs allocated with the same function	NO.1	Yes	1	1	1
Er.131	Number of DO functions exceeding the limit	NO.1	Yes	1	1	1
Er.207	Shaft D/Q current overflow	NO.1	Yes	1	1	0
Er.400	Main circuit overvoltage	NO.1	Yes	0	1	1
Er.410	Main circuit undervoltage	NO.1	Yes	1	1	0
Er.500	Servo motor overspeed	NO.1	Yes	0	1	0
Er.602	Angle auto-tuning failure	NO.1	Yes	0	0	0

c. NO.2 resettable fault

Display	Fault Name	Type	Resettable	DO Output		
				AL3	AL2	AL1
Er.121	Invalid S-ON command	NO.2	Yes	1	1	1
Er.410	Main circuit undervoltage	NO.2	Yes	1	1	0
Er.420	Power cable phase loss	NO.2	Yes	0	1	1
Er.510	Pulse output overspeed	NO.2	Yes	0	0	0
Er.610	Servo drive overload	NO.2	Yes	0	1	0
Er.620	Motor overload	NO.2	Yes	0	0	0
Er.630	Motor rotor locked	NO.2	Yes	0	0	0
Er.650	Heatsink overheat	NO.2	Yes	0	0	0
Er.731	Encoder battery failed	NO.2	Yes	1	1	1
Er.733	Encoder multi-revolution counting error	NO.2	Yes	1	1	1
Er.735	Encoder multi-revolution counting overflow	NO.2	Yes	1	1	1
Er.B00	Position deviation being large	NO.2	Yes	1	0	0
Er.B01	Pulse input abnormal	NO.2	Yes	1	0	0
Er.B02	Position deviation being too large in full closed-loop	NO.2	Yes	1	0	0
Er.B03	Electronic gear ratio setting exceeding the limit	NO.2	Yes	1	0	0
Er.B04	Full closed-loop function parameter setting error	NO.2	Yes	1	0	0
Er.D03	CAN communication interrupted	NO.2	Yes	1	0	1

d. Warning: resettable

Display	Warning Name	Fault Type	Resettable	DO Output		
				AL3	AL2	AL1
Er.110	Setting error of frequency-division pulse output	NO.3	Yes	1	1	1
Er.601	Homing timeout	NO.3	Yes	0	0	0
Er.730	Encoder battery warning	NO.3	Yes	1	1	1
Er.831	AI zero drift too large	NO.3	Yes	1	1	1
Er.900	DI emergency braking	NO.3	Yes	1	1	1
Er.909	Motor overload warning	NO.3	Yes	1	1	0
Er.920	Regenerative resistor overload	NO.3	Yes	1	0	1
Er.922	Resistance of external braking resistor too small	NO.3	Yes	1	0	1
Er.939	Motor power cable breaking	NO.3	Yes	1	0	0
Er.941	Parameter modification taking effect only after re-power-on	NO.3	Yes	0	1	1
Er.942	Parameter storage too frequent	NO.3	Yes	0	1	1

Display	Warning Name	Fault Type	Resettable	DO Output		
				AL3	AL2	AL1
Er.950	Forward limit switch warning	NO.3	Yes	0	0	0
Er.952	Reverse limit switch warning	NO.3	Yes	0	0	0
Er.980	Encoder internal fault	NO.3	Yes	0	0	1
Er.990	Power input phase loss warning	NO.3	Yes	0	0	1
Er.994	CAN address conflict	NO.3	Yes	0	0	1
Er.A40	Internal fault	NO.3	Yes	0	1	0

8.2.2 Troubleshooting of Faults

1. Er.101: Groups H02 and above parameters abnormal

Cause:

- Total number of function codes changes, which generally occurs after software update.
- Actual values of groups H02 and above parameters exceed the limit, which generally occurs after software update.

Cause	Confirming Methods	Corrective Action
1. The control power voltage drops instantaneously.	Check whether it is in the process of cutting off control power (L1C, L2C) or whether instantaneous power failure occurs.	Restore default setting (H02-31 = 1), and write the parameters again.
	Measure whether the control power voltage on the non-drive side is within the following specifications: 220 VAC drive: Valid value: 220 to 240 V Allowed error: -10% to 10% (198 to 264 V) 380 VAC drive: Valid value 380 to 480 V Allowed error: -10% to 10% (342 to 528 V)	Increase power capacity or replace with large-capacitance power supply, restore default setting (H02-31 = 1), and write the parameters again.
2. Instantaneous power failure occurs during parameter storage	Check whether instantaneous power failure occurs during parameter storage.	Re-power on the system, restore default setting (H02-31 = 1), and write the parameters again.
3. The times of parameter writing within a certain period exceeds the limit.	Check whether parameter update is performed frequently from the host controller.	Change parameter writing method and write parameters again. If servo drive is faulty, replace it
4. The software is upgraded.	Check whether software is upgraded.	Set servo drive model and servo motor model again, and restore default setting (H02-31 = 1).

Cause	Confirming Methods	Corrective Action
5. The servo drive is faulty.	If the fault persists after you power on servo drive several times and restore default setting, it indicates that the servo drive is faulty.	Replace the servo drive.

2. Er.102: Programmable logic configuration fault

Cause:

- The FPGA software version and the MCU software version do not match.
- The FPGA or MCU related hardware is damaged, resulting in communication failure between the MCU and FPGA.

Cause	Confirming Methods	Corrective Action
1. The FPGA software version and the MCU software version do not match.	View the MCU software version (H1-00) and the FPGA software version (H1-01) via operating panel or Inovance servo commissioning software. Check whether the non-zero numbers of the most significant bit of the versions are consistent.	Contact Inovance for technical support. Update matching FPGA or MCU software.
2. The FPGA is faulty.	The fault persists after you power on the servo drive several times.	Replace the servo drive.

3. Er.104: Programmable logic interruption

To distinguish fault symptom, the servo drive displays different internal fault codes under the same fault code. You can view these internal fault codes in H0B-44.

Cause:

Access to MCU or FPGA times out.

Cause	Confirming Methods	Corrective Action
1. The FPGA is faulty (E4.104).	The fault persists after you power on the servo drive several times.	Replace the servo drive.
2. The communication between the FPGA and the MCU is abnormal (Er.100).		
3. The drive internal operation times out (Er.940).		

4. Er.105: Internal program abnormal

Cause:

- Total number of parameters is abnormal at EEPROM reading/writing operation.
- Setting range of parameters is abnormal, which generally occurs after software update.

Cause	Confirming Methods	Corrective Action
1. An EEPROM fault occurs.	Check causes according to the method of Er.101.	Restore default setting (H02-31 = 1), and power on the servo drive again.
2. The servo drive is faulty.	The fault persists after you power on servo drive several times.	Replace the servo drive.

5. Er.108: Parameter storage fault

Cause:

- Parameter values cannot be written to EEPROM.
- Parameter values cannot be read from EEPROM.

Cause	Confirming Methods	Corrective Action
1. EEPROM writing is abnormal.	Modify a parameter, power on servo drive again, and check whether modification is saved.	If modification is not saved and the fault persists after servo drive is powered on several times, replace the servo drive.
2. EEPROM reading is abnormal.		

6. Er.120: Product model matching fault

Cause:

Rated motor current is larger than rated current of the servo drive.

Cause	Confirming Methods	Corrective Action
1. Product (motor or servo drive) SN does not exist.	View servo drive and servo motor nameplates to check that the equipment you are using is IS620P series servo drive and 20-bit servo motor (-U2***) of Inovance. Meanwhile, check whether H00-00 (Motor SN) is 14000.	Servo motor SN does not exist. If you use IS620P series servo drive and 20-bit servo motor (-U2***) of Inovance, ensure that H00-00 = 14000.
	View servo drive SN (H01-02) and check whether servo drive SN exists by referring to section 1.3.	Servo drive SN does not exist. Set servo drive SN correctly by referring to section 1.3.
Power class of servo motor and servo drive does not match.	Check whether servo drive SN (H01-02) and serial encoder motor SN (H00-05) match by referring to section 1.3.	Replace unmatched product by referring to section 1.3.

7. Er.121: S-ON signal invalid

Cause:

When some auxiliary functions are used, redundant S-ON signal is given.

Cause	Confirming Methods	Corrective Action
When servo drive is enabled internally, external S-ON signal is valid.	Check whether auxiliary functions (H0D-02, H0D-03, H0D-12) are used and whether DI function FunIN.1: S-ON is ON.	Set DI function FunIN.1: S-ON (both hardware DI and virtual DI) to OFF.

8

8. Er.122: Product matching fault in absolute position mode

Cause: The motor in absolute position mode does not match or motor SN is set incorrectly.

Cause	Confirming Methods	Corrective Action
The motor in absolute position mode does not match or motor SN is set incorrectly.	Check whether motor nameplate is multi-turn absolute encoder motor. Check whether H00-00 (motor SN) is correct.	Set H00-00 correctly or replace matching motor according to motor nameplate.

9. Er.130: Different DIs allocated with the same function

Cause:

The same function is allocated to different DIs, including hardware DI and virtual DI.

The DI function No. exceeds the number of DI functions.

Cause	Confirming Methods	Corrective Action
1. The same function is allocated to different DIs.	Check whether parameters in groups H03 (H03-02 to H03-20) and H17 (H17-00 to H17-30) are set for the same non-zero DI function.	Re-allocate the parameters that have been allocated with the same non-zero DI function with different DI functions. Then re-connect control power to make modification take effect. Or set the S-ON signal to OFF and give the reset signal to make modification take effect.
2. The DI function No. exceeds the number of DI functions.	Check whether MCU program is updated.	Restore default setting (H02-31 = 1), and power on the servo drive again.

10. Er.131: Number of DO functions exceeding the limit

Cause:

The DO function No. exceeds the number of DO functions.

Cause	Confirming Methods	Corrective Action
1. The DO function No. exceeds the number of DO functions.	Check whether MCU program is updated.	Restore default setting (H02-31 = 1), and power on the servo drive again.

11. Er.136: Data check error or no parameter stored in the motor ROM

Cause:

When servo drive reads parameters from encoder ROM, it finds that no parameters are saved there or parameter value is inconsistent with the agreed value.

Cause	Confirming Methods	Corrective Action
1. Servo drive model and servo motor model do not match.	View servo drive and servo motor nameplates to check that the equipment you are using is IS620P series servo drive and 20-bit servo motor (-U2***) of Inovance.	Replace matched servo drive and servo motor and power on the system again. If you use IS620P series servo drive and 20-bit servo motor (-U2***) of Inovance, ensure that H00-00 = 14000.
2. A parameter check error occurs or no parameter is stored in the serial encoder ROM memory.	Check whether encoder cable you use is standard configuration of Inovance. For cable specification, refer to Chapter 3. The cable must not scratch, break or be in poor contact. The cable must be connected reliably. Measure signals PS+, PS-, +5V and GND at both ends of encoder cable and observe whether signals at both ends are consistent. For definition of signals, refer to Chapter 3.	Ensure that encoder cable you use is configured by Inovance as standard. Ensure that the cable is connected to the motor securely and tighten the screw on the drive side. If necessary, use a new encoder cable. Never bundle encoder cable and power cables (RST, UVW) together.
3. Servo drive faulty.	The fault persists after servo drive is powered on again.	Replace the servo drive.

12. Er.200: Overcurrent 1

Cause:

Any phase feedback current is larger than the overcurrent threshold of the servo drive.

13. Er.201: Overcurrent 2

Cause:

Hardware overcurrent is detected.

Cause	Confirming Methods	Corrective Action
1. References are input simultaneously at servo startup or reference input is too quick.	Check whether an reference is input before the keypad displays "rdy".	The time sequence is: after the keypad displays "rdy", set the S-ON signal (S-ON) to ON and then input reference. If allowed, add reference filter time constant or increase acceleration/ deceleration time.
2. The regenerative resistor is too small or short circuited.	If internal regenerative resistor is used (H02-25 = 0), check whether P _⊕ and D are connected with a cable reliably. If yes, measure resistance between C and D. If external regenerative resistor is used (H02-25 = 1/2), measure resistance between P _⊕ and C. For regenerative resistor specification, refer to Chapter 5.	If internal regenerative resistor is used and the resistance is 0, use external regenerative resistor (H02-25 = 1/2) and remove cable between P _⊕ and D. select external regenerative resistor of the same resistance and power as internal regenerative resistor. If external regenerative resistor is used and the resistance is smaller than H02-21 (allowed minimum value of regenerative resistor), connect a new regenerative resistor between P _⊕ and C by referring to the regenerative resistor specification in Chapter 1. Make H02-26 (power of external regenerative resistor) and H02-27 (resistance of external regenerative resistor) consistent with external regenerative resistor specification.
3. Motor cables are in poor contact.	Check whether power cables of servo drive and motor UVW cables are loose.	Fasten the cables that become loose or are disconnected.
4. Motor cables are grounded.	After ensuring power cables of servo drive and motor cables are connected securely, measure insulation resistance between UVW of servo drive and ground cable (PE) and check whether insulation resistance is MΩ-level.	Replace motor if insulation is poor.
5. Motor UVW cables are short circuited.	Disconnect motor cables and check whether motor cables (U, V, W) are short circuited and whether burrs exist.	Connect motor cables correctly.
6. Motor is damaged.	Disconnect motor cables and measure whether resistance between motor cables UVW is balanced.	Replace motor if resistance is unbalanced.

Cause	Confirming Methods	Corrective Action
7. The gain setting is improper and motor oscillates	Check whether motor oscillates or generates a shrill noise during motor startup and running. You can view current feedback by using the drive Inovance servo commissioning software.	Adjust the gain by referring to Chapter 6.
8. Encoder cable is incorrectly wired, corrosive, or connected loosely.	Check whether encoder cable you use is standard configuration of Inovance. check whether cable is aging, corrosive or is connected loosely. Set the S-ON signal to OFF and rotate motor shaft manually. Check whether H0B-10 (electric angle) changes as motor rotates.	Re-weld, fasten or replace encoder cable.
9. Servo drive faulty.	The fault persists after motor cables are disconnected and servo drive is powered on again.	Replace the servo drive.

14. Er.207: Shaft D/Q current overflow

Cause:

Abnormal current feedback results in overflow of internal register of servo drive.

Abnormal encoder feedback results in overflow of internal register of servo drive.

Cause	Confirming Methods	Corrective Action
1. Shaft D/Q current overflows.	If the fault persists after you power on servo drive several times and restore default setting, it indicates that the servo drive is faulty.	Replace the servo drive.

15. Er.208: FPGA system sampling operation timeout

Cause:

Find the cause through internal fault code H0B-45 when Er.208 occurs.

Cause	Confirming Methods	Corrective Action
1. MCU communication times out.	Internal fault code H0B-45 = 1208. Internal chip is damaged.	Replace the servo drive.

Cause	Confirming Methods	Corrective Action
2. Communication with encoder times out.	<p>Internal fault code H0B-45 = 2208.</p> <p>Encoder wiring is incorrect.</p> <p>Encoder cable becomes loose.</p> <p>Encoder cable is too long.</p> <p>Communication with encoder is interrupted.</p> <p>The encoder is faulty.</p>	<p>Use encoder cable that is configured as standard by Inovance. If not, check whether encoder cable comply with specification and whether it is shielded twisted pair cable.</p> <p>Check whether plugs at both ends of encoder are in good contact and whether any pin retracts.</p> <p>Contact the manufacturer.</p> <p>Do not bundle motor cables and encoder cables together. Ensure servo motor and servo drive are well grounded.</p> <p>Replace servo motor.</p>
3. Current sampling times out.	<p>Internal fault code H0B-45 = 3208.</p> <p>Check whether there is large equipment generating interference on site and whether there are multiple interference sources in the cabinet.</p> <p>Internal current sampling chip is damaged.</p>	<p>Separate heavy current from light current and do not bundle them together.</p> <p>Replace the servo drive.</p>
4. High-accuracy AD conversion times out.	<p>Internal fault code H0B-45 = 4208.</p> <p>Interference exists in high-accuracy AI channel. Check AI wiring according to correct wiring diagram.</p>	<p>Use shielded twisted pair cable and shorten cable length.</p>
5. FPGA operation times out.	<p>Internal fault code H0B-45 = 0208.</p> <p>Remove the cause according to preceding 1/2/3/4.</p>	<p>Perform corrective action according to preceding 1/2/3/4.</p>

16. Er.210: Output short-circuit to ground

Cause:

Servo drive detects motor phase current or bus voltage abnormal during self-check at power-on.

Cause	Confirming Methods	Corrective Action
1. Power output cables (UVW) of servo drive are short-circuited to ground.	<p>Disconnect UVW cables from motor, and measure whether motor UVW cables are short-circuited to ground.</p>	<p>Re-connect these cables or replace them.</p>
2. Motor is short-circuited to ground.	<p>After ensuring power cables of servo drive and motor cables are connected securely, measure insulation resistance between UVW of servo drive and ground cable (PE) and check whether insulation resistance is MΩ-level.</p>	<p>Replace servo motor.</p>
3. Servo drive faulty.	<p>Remove power cables from servo drive. The fault persists after the drive is powered on several times.</p>	<p>Replace the servo drive.</p>

17. Er.220: Internal fault

18. Er.234: Runaway

Cause:

Torque reference direction is reverse to speed feedback direction in torque control.

Speed feedback direction is reverse to speed reference direction in position or speed control.

Cause	Confirming Methods	Corrective Action
1. UVW phase sequence is incorrect.	Check whether UVW phase sequence on servo drive is consistent with that on motor side.	Connect UVW cables according to correct phase sequence.
Motor rotor initial phase detection is incorrect due to interference at power-on.	UVW phase sequence is correct. But Er.234 occurs once servo drive is enabled.	Re-power on the servo system.
3. Encoder type is set incorrectly or wiring is incorrect.	View servo drive and servo motor nameplates to check that the equipment you are using is IS620P series servo drive and 20-bit servo motor (-U2***) of Inovance.	Replace matching servo drive and servo motor. If you use IS620P series servo drive and 20-bit servo motor (-U2***) of Inovance, ensure that H00-00 = 14000. Re-confirm motor model, encoder type and encoder wiring.
4. Encoder cable is incorrectly wired, corrosive, or connected loosely.	Check whether encoder cable you use is standard configuration of Inovance. check whether cable is aging, corrosive or is connected loosely. Set the S-ON signal to OFF and rotate motor shaft manually. Check whether H0B-10 (electric angle) changes as motor rotates.	Re-weld, fasten or replace encoder cable.
When controlling a vertical shaft, gravity load is too large.	Check whether load of vertical shaft is too large. Adjust brake parameters H02-09 to H02-12 and then see whether the fault is removed.	Reduce load of vertical shaft, improve rigidity or shield this fault on the prerequisite of not affecting safety and use.



CAUTION

On working condition of controlling a vertical shaft or one motor dragging the other, set H0A-12 = 0 to shield the runaway fault.

19. Er.400: Main circuit overvoltage

Cause:

DC bus voltage between P_⊕ and ⊖ exceeds overvoltage level.

220 VAC drive: normal value: 310 V, overvoltage level: 420 V

380 VAC drive: normal value: 540 V, overvoltage level: 760 V

Cause	Confirming Methods	Corrective Action
1. Main circuit input voltage is too high	<p>Check power input specification of servo drive. Measure RST input voltage on servo drive side and check whether input voltage complies with the following specification.</p> <p>220 VAC drive: Valid value: 220 to 240 V Allowed error: -10% to 10% (198 to 264 V)</p> <p>380 VAC drive: Valid value: 380 to 480 V Allowed error: -10% to 10% (342 to 528 V)</p>	Replace power supply or adjust power voltage according to specification on the left.
2. Power supply is instable or affected by the lightning strike.	Check whether power supply is instable, affected by lightning strike or satisfies preceding specification.	Connect a surge suppressor and then connect power supply. If the fault persists, replace the servo drive.
3. The regenerative resistor fails.	<p>If internal regenerative resistor is used (H02-25 = 0), check whether P_⊕ and D are connected with a cable reliably. If yes, measure resistance between C and D.</p> <p>If external regenerative resistor is used (H02-25 = 1/2), measure resistance between P_⊕ and C.</p> <p>For regenerative resistor specification, refer to Chapter 5.</p>	<p>If resistance is ∞, wire breaking occurs.</p> <p>If internal regenerative resistor is used and resistance is 0, use external regenerative resistor (H02-25 = 1/2) and remove cable between P_⊕ and D. Select external regenerative resistor of the same resistance and power as internal regenerative resistor.</p> <p>If external regenerative resistor is used, connect a new regenerative resistor between P_⊕ and C.</p> <p>Make H02-26 (power of external regenerative resistor) and H02-27 (resistance of external regenerative resistor) consistent with external regenerative resistor specification.</p>
4. Resistance of the regenerative resistor is too large, and energy absorption during braking is insufficient.	Measure resistance of the external regenerative resistor between P _⊕ and C. Compare the measured value with the recommended value.	<p>Connect a new external regenerative resistor of recommended resistance between P_⊕ and C.</p> <p>Make H02-26 (power of external regenerative resistor) and H02-27 (resistance of external regenerative resistor) consistent with external regenerative resistor specification.</p>
5. Motor is in abrupt acceleration/ deceleration status. Maximum braking energy exceeds energy absorption value.	Confirm acceleration/deceleration time during running and measure DC bus voltage between P _⊕ and ⊖. Check whether voltage exceeds fault level during deceleration.	First, ensure that input voltage of main circuit is within specification. Then increase/decrease acceleration/ deceleration time in allowed range.

Cause	Confirming Methods	Corrective Action
6. Bus voltage sampling value has a large deviation from the measured value	<p>Check whether H0B-26 (bus voltage) is within the following specification:</p> <p>220 V drive: H0B-26 > 420 V</p> <p>380 V drive: H0B-26 > 760V</p> <p>Measure the DC bus voltage between P_⊕ and ⊖. Check whether the DC bus voltage is normal and smaller than H0B-26.</p>	Contact Inovance for technical support.
7. The servo drive is faulty.	The fault persists after main circuit is powered on several times.	Replace the servo drive.

20. Er.410: Main circuit undervoltage

Cause:

DC bus voltage between P_⊕ and ⊖ is lower than undervoltage level.

220 VAC drive: normal value: 310 V, undervoltage level: 200V

380 VAC drive: normal value: 540V, undervoltage level: 380V

Cause	Confirming Methods	Corrective Action
1. The main power is unstable or fails.	<p>Check power input specification of servo drive. Measure RST input voltage on servo drive side and check whether input voltage complies with the following specification.</p> <p>220 AC drive:</p>	Increase power capacity. For details, refer to Chapter 1.
2. Instantaneous power down occurs.	<p>Valid value: 220 to 240 V</p> <p>Allowed error: -10% to 10% (198 to 264 V)</p> <p>380 VAC drive:</p> <p>Valid value: 380 to 480 V</p> <p>Allowed error: -10% to 10% (342 to 528 V)</p> <p>All the three phases must be measured.</p>	
3. Voltage dip occurs during running.	Check power input voltage and check whether main power is applied to other devices, resulting insufficient power capacity and voltage dip.	
4. Phase loss exists: Single-phase power is applied to three-phase servo drive.	Check whether main circuit RST wiring is correct and reliable, and whether phase loss fault detection (H0A-00) is shielded.	<p>Replace cables and connect main circuit correctly.</p> <p>Three phases: R, S, T</p> <p>Single-phase: L1, L2</p>
5. The servo drive is faulty.	<p>Check whether H0B-26 (bus voltage) is within the following specification:</p> <p>220V drive: H0B-26 < 200 V</p> <p>380 V drive: H0B-26 < 380 V</p> <p>The fault persists after main circuit is powered on several times.</p>	Replace the servo drive.

21. Er.420: Power cable phase loss

Cause:

Phase loss occurs on three-phase servo drive.

Cause	Confirming Methods	Corrective Action
The RST cables are not connected well.	Check whether RST cables on servo drive side and non-servo drive side are in good condition and connected securely.	Replace cables and connect main circuit correctly.
2. Single-phase power is applied to three-phase servo drive.	Confirm power input specification and actual input voltage. Check whether input voltage of each phase of main circuit satisfies the following specification: 220 VAC drive: Valid value: 220 to 240 V Allowed error: -10% to 10% (198 to 264 V) 380 VAC drive: Valid value: 380 to 480 V Allowed error: -10% to 10% (342 to 528 V) All the three phases must be measured.	For servo drive of 0.75 kW (H01-02 = 5), it can be applied by single-phase power supply. If input voltage satisfies specification on the left, set H0A-00 = 2 (forbid faults and warnings). If input voltage does not satisfy specification on the left, replace or adjust power capacity.
3. Three-phase voltage is unbalanced or voltages of all three phases are too low.		
4. The servo drive is faulty.	The fault persists after main circuit (R, S, T) is powered on several times.	Replace the servo drive.

22. Er.430: Control power undervoltage

Cause:

220 VAC drive: normal value: 310 V, undervoltage level: 190 V

380 VAC drive: normal value: 540 V, undervoltage level: 350 V

Cause	Confirming Methods	Corrective Action
1. The control power is unstable or fails.	Check whether it is in the process of cutting off the control power (L1C, L2C) or instantaneous power failure occurs.	Re-power on the servo drive. If the fault is abnormal power failure, keep power supply stable.
	Check whether input voltage of control cables satisfies the following specification: 220 VAC drive: Valid value: 220 to 240 V Allowed error: -10% to 10% (198 to 264 V) 380 VAC drive: Valid value: 380 to 480 V Allowed error: -10% to 10% (342 to 528 V)	Increase power capacity.

Cause	Confirming Methods	Corrective Action
2. The control power cables are in poor contact.	Check whether control cables are well connected and whether voltage of control cables (L1C, L2C) satisfies preceding specification.	Re-connect or replace control power cables.

23. Er.500: Overspeed

Cause:

Actual speed of servo motor exceeds overspeed level.

Cause	Confirming Methods	Corrective Action
1. UVW phase sequence is incorrect.	Check whether UVW phase sequence on servo drive is consistent with that on motor side.	Connect UVW cables according to correct phase sequence.
2. The setting of H0A-08 is incorrect.	Check whether overspeed level is smaller actual maximum motor speed. Overspeed level = 1.2 times of maximum motor speed (H0A-08 = 0) Overspeed level = H0A-08 (H0A-08 ≠ 0, and H0A-08 < 1.2 times of maximum motor speed)	Reset overspeed level according to actual mechanical requirement.
3 Input reference is higher than overspeed level.	Check whether motor speed corresponding to input reference exceeds overspeed level. When the reference source is pulse in the position control mode: Motor speed (rpm) = $\frac{\text{Input pulse frequency (Hz)}}{\text{Encoder resolution}} \times \text{Electronic gear ratio} \times 60$ For IS620P servo drive, the encoder resolution is 1048576P/r.	In position control: When reference source is pulse, reduce pulse frequency in the prerequisite of ensuring accurate positioning or decrease the electronic gear ration if motor speed allows. In speed control: View speed reference and speed limit (H06-06 to H06-09) and confirm that they are within the overpseed level. In torque control: Set speed limit within the overspeed level. For speed limit in torque control, refer to section 5.4.4.
4. Motor speed overshoots.	Check whether speed feedback exceeds overspeed level through the Inovance servo commissioning software.	Adjust the gain or adjust mechanical condition by referring to Chapter 6.
5. The servo drive is faulty.	The fault persists after servo drive is re-powered on.	Replace the servo drive.

24. Er.510: Pulse output overspeed

Cause:

When pulse output function is used (H05-38 = 0 or 1), the output pulse frequency exceeds frequency upper limit allowed by the hardware (2 MHz).

Cause	Confirming Methods	Corrective Action
Output pulse frequency exceeds frequency upper limit allowed by hardware (2 MHz).	When H05-38 = 0 (encoder frequency-division output), calculate pulse frequency corresponding to motor speed at occurrence of fault and check whether the pulse frequency exceeds limit. Output pulse frequency (Hz) = $\frac{\text{Motor speed (rpm)}}{60} \times \text{H05-17}$	Decrease H05-17(Encoder frequency-division pulses), making output pulse frequency below frequency upper limit allowed by hardware in the speed range required by mechanical condition.
	When H05-38 = 1 (reference pulse synchronous output), input pulse frequency exceeds 2 MHz or interference exists on pulse input pin. Low-speed pulse input pin: Differential input terminals, PULSE+, PULSE-, SIGN+, SIGN- Max. pulse frequency: 500 kpps Open-collector input terminals, PULLHI, PULSE+, PULSE-, SIGN+, SIGN- Max. pulse frequency: 200 kbps High-speed pulse input pin: Differential input terminals: HPULSE+, HPULSE-, HSIGN+, HSIGN- Max. pulse frequency: 2 Mpps	Decrease input pulse frequency to within frequency upper limit allowed by hardware. In this case, if you do not modify electronic gear ratio, motor speed will slow down. If input pulse frequency is very high but is still within frequency upper limit allowed by hardware, take anti-interference measures (use STP cable for pulse input and set pin filter parameters H0A-24 or H0A-30), which prevents interference pulse adding to pulse and resulting in fault misreported.

25. Er.602: Angle auto-tuning failure

26. Er.610: Servo drive overload

Cause:

Heat accumulation of the servo drive reaches the fault level.

Cause	Confirming Methods	Corrective Action
1. Parameter setting is incorrect.	Check whether H01-02 (drive SN) is set correctly. Check whether the gain parameters (group H08) or the stiffness (H09-00 and H09-01) are set correctly.	Set H01-02 according to the actual drive SN. Adjust the parameters based on the current feedback effect.
The servo drive load ratio is too large (load inertia excessive).	Check whether H0B-12 (average load ratio) is excessive (over 80%) and then whether the inertia is excessive through inertia auto-tuning.	Use a drive model of higher power.
3. The servo drive load ratio is too large (mechanical stuck)	Check whether H0B-12 (average load ratio) is excessive (over 80%) and then whether stuck occurs during load running.	Eliminate the mechanical stuck problem.
4. Locked rotor occurs in the motor.	Check whether H0A-33 (locked rotor over-temperature protection) is 0. If yes, the drive trips Er.610 when locked rotor occurs.	Take actions for Er.630.

27. Er.620: Motor overload

Cause:

Heat accumulation of the servo motor reaches the fault level.

Cause	Confirming Methods	Corrective Action
1. Wiring of motor and encoder is incorrect or poor.	Check wirings between servo drive, servo motor and encoder according to correct wiring diagram.	Connect wirings based on correct wiring diagram. Prefer to use the cable configured by Inovance as standard. When self-made cable is used, make and connect wirings according to hardware wiring guidance.
2. The load is too heavy. The motor keeps output of effective torque higher than rated torque for a long time.	Confirm overload characteristic of servo drive or servo motor. Check whether average load rate (H0B-12) is greater than 100.0% for long time.	Replace a large servo drive and matching servo motor. Reduce the load and increase acceleration/deceleration time.
3. Acceleration/ deceleration is too frequent or the load inertia is too large.	Calculate the load inertia ratio or perform the load inertia ratio auto-tuning. Then view H08-15 (load inertia ratio). Conform single running cycle when servo motor runs in circular.	Increase acceleration/deceleration time during single running.
4. The gain is improper, causing too high rigidity.	Observe whether motor vibrates and generates noise during running.	Adjust the gain by referring to Chapter 6.
5. The servo drive or motor model is set incorrectly.	For IS620P series products, view serial encoder motor model in H00-05 and servo drive model in H01-02. For IS600P series products, view serial encoder motor model in H00-05 and servo drive model in H01-02.	View servo drive nameplate and set servo drive model (H01-02) correctly and use the matching servo motor model according to section 1.3.
6. Locked-rotor occurs due to mechanical factors, resulting in very heavy load during running.	Check running reference and motor speed (H0B-00) by using the drive Inovance servo commissioning software or keypad. Running reference in position control: H0B-13 (input reference pulse counter) Running reference in speed control: H0B-01 (speed reference) Running reference in torque control: H0B-02 (internal torque reference) Check running reference in corresponding mode is not 0 but the motor speed is 0.	Eliminate mechanical factors.
7. The servo drive is faulty.	The fault persists after servo drive is powered on again.	Replace the servo drive.

**CAUTION**

You can clear the fault or re-power on the system 30s after overload occurs.

28. Er.630: Overheat protection of locked-rotor motor

Cause:

Actual motor speed is lower than 10 rpm but torque reference reaches the limit. The duration reaches the value set in H0A-32.

Cause	Confirming Methods	Corrective Action
1. Power output phase (UVW) loss or incorrect phase sequence occurs on servo drive.	Perform motor trial running when there is no load and check motor wirings.	Connect motor cables correctly again or replace them.
2. UVW cable or encoder cable breaks.	Check wirings.	Connect wirings correctly again or replace them.
3. Motor rotor is locked due to mechanical factors.	<p>Check running reference and motor speed (H0B-00) by using Inovance servo commissioning software or operating panel.</p> <p>Running reference in the position control mode: H0B-13 (input reference pulse counter)</p> <p>Running reference in speed control: H0B-01 (speed reference)</p> <p>Running reference in torque control: H0B-02 (internal torque reference)</p> <p>Check running reference in corresponding mode is not 0 but the motor speed is 0.</p>	Eliminate mechanical factors.

29. Er.650: Heatsink overheat

Cause:

Temperature of power module of servo drive is higher than the overtemperature protection level.

Cause	Confirming Methods	Corrective Action
1. Ambient temperature is too high.	Measure ambient temperature.	Improve cooling conditions to reduce ambient temperature.
2. Servo drive is powered off to reset overload fault.	View the fault records (set H0B-33 and view H0B-34) and check whether overload fault (Er.610, Er.620, Er.630, Er.650, Er.909, Er.920, Er.922) occurs.	Change fault reset method. After overload occurs, wait 30s and then perform reset operation. Increase capacity of servo drive and servo motor, increase acceleration/ deceleration time, and reduce load.
3. The fan is damaged.	Observe whether the fan rotates during running.	Replace the servo drive.
4. Installation direction and clearance of the servo drive are improper.	Check whether installation of servo drive is proper.	Install servo drive according to mounting requirements.
5. The servo drive is faulty.	The fault persists after restart 5 minutes after power-off.	Replace the servo drive.

30. Er.731: Encoder battery failure

Cause: Battery voltage of absolute encoder is lower than 3.0 V.

Cause	Confirming Methods	Corrective Action
The battery is not connected during power-off.	Check whether battery is connected during power-off.	Set H0D-20 = 1 to remove the fault.
The encoder battery voltage is too low.	Measure the battery voltage.	Replace a new battery with matching voltage.

31. Er.733: Encoder multi-revolution counting error

Cause: Encoder multi-revolution counting is wrong.

Cause	Confirming Methods	Corrective Action
The encoder is faulty.	Set H0D-20 = 1 to remove the fault. Er.733 persists after power-on again.	Replace servo motor.

32. Er.735: Encoder multi-revolution counting overflow

Cause: Encoder multi-revolution counting overflows.

Cause	Confirming Methods	Corrective Action
Encoder multi-revolution counting overflow is detected when H02-01 = 1.	-	Set H0D-20 = 1 and power on the system again.

33. Er.740: Encoder interference

Cause:

The encoder Z signal suffers interference, resulting in too large change of corresponding electrical angle of Z signal.

Cause	Confirming Methods	Corrective Action
1. Encoder wiring is incorrect.	Check encoder wiring.	Re-connect the encoder according to correct wiring diagram.
2. Encoder cable becomes loose.	Check whether on-site vibration is too large, which loosens encoder cable and even damages the encoder.	Re-connect encoder cable securely.

Cause	Confirming Methods	Corrective Action
3. The encoder Z signal suffers interference	<p>Check on-site wirings:</p> <p>Check whether there is large equipment generating interference around servo system or whether there are several variable-frequency power devices inside the cabinet.</p> <p>Make servo drive in "rdy" status and rotate motor shaft counterclockwise (CCW) manually and observe whether H0B-10 (rotation angle/electrical angle) increases/decreases smoothly. Turning one circle corresponds to five 0-360° (for Z series motor).</p> <p>For X series motor, turning one circle corresponds to four 0-360°.</p> <p>If H0B-10 changes abnormally during rotation, it indicates that a fault occurs on encoder.</p> <p>If there is no alarm during rotation but the system alarms during servo running, it is extremely possible that interference exists.</p>	<p>Prefer to use the cable configured by Inovance as standard.</p> <p>If non-standard cable is used, check whether the cable meets requirements and is STP cable.</p> <p>Do not bundle motor cables and encoder cables together. Ensure servo motor and servo drive are well grounded.</p> <p>Check whether plugs at both ends of encoder are in good contact and whether any pin retracts.</p>
4. The encoder is faulty.	<p>Replace a new encoder cable. If the fault no longer occurs after replacement, it indicates that the original encoder is damaged</p> <p>Place motor at the same position, power on the system several times and observe change of H0B-10. The electrical angle must be within $\pm 30^\circ$</p>	<p>Replace a new encoder cable.</p> <p>If not, it indicates that the encoder is damaged. You need to replace servo motor.</p>

34. Er.834: AD sampling overvoltage

Cause:

AI sampling value is greater than 11.5 V.

Cause	Confirming Methods	Corrective Action
1. AI voltage is too high.	Measure voltage input from AI and check whether AI sampling voltage (H0B-21 or H0B-22) is greater than 11.5 V.	Adjust AI input voltage and view AI sampling voltage until AI sampling voltage does not exceed 11.5 V.
2. AI wiring is incorrect or interference exists.	Check AI wiring according to correct wiring diagram.	<p>Use shielded twisted pair cable and shorten cable length.</p> <p>Increase AI filter time constant: AI1 filter time constant: H03-51 AI2 filter time constant: H03-56</p>

35. Er.835: High-accuracy AD sampling fault

Cause:

High-accuracy AD circuit suffers interference.

Cause	Confirming Methods	Corrective Action
1. Interference exists on high-accuracy AI.	Check AI wiring according to correct wiring diagram.	Use shielded twisted pair cable and shorten cable length.

36. Er.A33: Encoder data abnormal

Cause:

Encoder internal parameters are abnormal.

Cause	Confirming Methods	Corrective Action
1. The serial encoder cable breaks or becomes loose.	Check wirings.	Check connection of encoder cable to see whether incorrect connection, wire breaking, or poor contact exists. If motor cables and encoder cable are bundled together, separate them.
2. Serial encoder parameters read-write is abnormal.	If the fault persists after you power on servo drive several times, it indicates that the encoder is faulty.	Replace servo motor.

37. Er.A34: Encoder communication check abnormal

Cause:

After power-on, reading initial phase information of rotor of 2500-PPR incremental encoder error occurs.

Cause	Confirming Methods	Corrective Action
1. Servo drive model and servo motor model do not match.	View servo drive and servo motor nameplates to check that the equipment you are using is IS620P series servo drive and 20-bit servo motor (-U2***) of Inovance. Meanwhile, check whether H00-00 (Motor SN) is 14000.	Replace matching servo drive and servo motor.
2. Encoder cable breaks.	Check whether encoder cable breaks and whether connection of servo drive and connection of servo motor are secure.	Replace a new encoder cable and secure wirings.

38. Er.A35: Z signal lost

Cause:

Z signal of 2500-PPR incremental encoder gets lost or edge of A, B signals changes simultaneously.

Cause	Confirming Methods	Corrective Action
1. Z signal gets lost because of encoder fault.	Use a new encoder cable and connect wirings correctly. Then rotate motor shaft manually and check whether the fault persists.	Replace servo motor.
Poor contact or incorrect connection results in Z signal lost.	Rotate motor shaft manually and check whether the fault persists.	Check whether encoder cable is in good contact. Re-connect wirings or replace encoder cable.

39. Er.B00: Position deviation being large

Cause:

Position deviation is larger than the setting of H0A-10 in position control.

Cause	Confirming Methods	Corrective Action
1. Power output phase (UVW) loss or incorrect phase sequence occurs on servo drive.	Perform motor trial running when there is no load and check motor wirings.	Connect wirings correctly again or replace them.
2. UVW cable or encoder cable breaks.	Check wirings.	Reconnect the UVW cable. Power cables of servo motor and power cables UVW of servo drive must be one-to-one correspondence. If necessary, replace a new cable and ensure reliable connection.
3. Motor rotor is locked due to mechanical factors.	<p>Check running reference and motor speed (H0B-00) by using Inovance servo commissioning software or operating panel.</p> <p>Running reference in the position control mode: H0B-13 (input reference pulse counter)</p> <p>Running reference in speed control: H0B-01 (speed reference)</p> <p>Running reference in torque control: H0B-02 (internal torque reference)</p> <p>Check running reference in corresponding mode is not 0 but the motor speed is 0.</p>	Eliminate mechanical factors.
4. Servo drive gain is low.	<p>Check servo drive position loop gain and speed loop gain.</p> <p>1st gain: H08-00 to H08-02</p> <p>2nd gain: H08-03 to H08-05</p>	Adjust gain manually or perform automatic gain auto-tuning according to Chapter 6.
5. Input pulse frequency is high.	<p>Check whether input pulse frequency is too high if position reference source is pulse.</p> <p>Acceleration/deceleration time is 0 or too small.</p>	<p>Reduce position reference frequency or decrease electronic gear ratio.</p> <p>When host computer is used to output position pulses, set acceleration/deceleration time in host computer.</p> <p>If host computer is not allowed to set acceleration/deceleration time, increase parameters H05-04 and H05-06 to smoothen position reference.</p>
6. Relative to running condition, H0A-10 (threshold of position deviation fault) is too small.	Check whether the setting of H0A-10 is too small.	Increase the setting of H0A-10.

Cause	Confirming Methods	Corrective Action
7. The servo drive/motor is faulty.	Monitor running curve in Inovance servo commissioning software: Position reference, position feedback, speed reference, torque reference	If position reference is not 0, but position feedback is always 0, replace servo drive/motor.

40. Er.B01: Pulse input abnormal

Cause:

Input pulse frequency is greater than H0A-09 (Maximum position pulse frequency).

Cause	Confirming Methods	Corrective Action
1. Input pulse frequency is greater than H0A-09 (Maximum position pulse frequency).	Check whether H0A-09 is smaller than maximum input pulse frequency required by normal machine running.	Reset H0A-09 correctly according to the actual requirement. If output pulse frequency of host computer is larger than 4 MHz, decrease it.
2. Input pulse suffers interference.	Check whether position reference increases abruptly or whether H0B-13 (input reference pulse counter) is larger than the number of pulses output by host computer through oscilloscope. Then check grounding situation of connecting cables.	First, use an STP cable for pulse input and separate pulse input cable from servo drive power cables. Then, when differential input is selected on the condition of using low-speed pulse input terminal (H05-01 = 0), ground of host computer must be connected to GND of servo drive reliably. If open-collector input is selected, ground of host computer must be connected to COM of servo drive reliably. Only differential input can be selected on the condition of using high-speed pulse input terminal (H05-01 = 1), ground of host computer must be connected to GND of servo drive reliably. Finally, according to selected hardware input terminal, increase pin filter time of pulse input terminal in H0A-24 or H0A-30.

41. Er.B02: Position deviation being too large in full closed-loop

Cause:

Absolute value of position deviation in full closed-loop exceeds the setting of H0F-08 (Full closed-loop position deviation exceeds threshold).

Cause	Confirming Methods	Corrective Action
1. Power output phase (UVW) loss or incorrect phase sequence occurs on servo drive.	Perform motor trial running when there is no load and check motor wirings.	Connect wirings correctly again or replace them.
2. UVW cable or internal/external encoder cable breaks.	Check wirings.	Reconnect the UVW cable. Power cables of servo motor and power cables UVW of servo drive must be one-to-one correspondence. If necessary, replace a new cable and ensure reliable connection.

Cause	Confirming Methods	Corrective Action
3. Motor rotor is locked due to mechanical factors.	<p>Check running reference and motor speed (H0B-00) by using Inovance servo commissioning software or operating panel.</p> <p>Running reference in the position control mode: H0B-13 (input reference pulse counter)</p> <p>Running reference in speed control: H0B-01 (speed reference)</p> <p>Running reference in torque control: H0B-02 (internal torque reference)</p> <p>Check running reference in corresponding mode is not 0 but the motor speed is 0.</p>	Eliminate mechanical factors.
4. Servo drive gain is low.	<p>Check servo drive position loop gain and speed loop gain.</p> <p>First gain: H08-00 to H08-02</p> <p>Second gain: H08-03 to H08-05</p>	Adjust gain manually or perform automatic gain auto-tuning according to Chapter 6.
5. Input pulse frequency is high.	<p>Check whether input pulse frequency is too high if position reference source is pulse.</p> <p>Acceleration/deceleration time is 0 or too small.</p>	<p>Reduce position reference frequency or decrease electronic gear ratio.</p> <p>When host computer is used to output position pulses, set acceleration/deceleration time in host computer.</p> <p>If host computer is not allowed to set acceleration/deceleration time, increase parameters H05-04 and H05-06 to smoothen position reference.</p>
6. Relative to running condition, H0F-08 (full closed-loop position deviation too large threshold) is too small.	<p>Check whether full closed-loop position deviation too large threshold (H0F-08) is too small.</p>	Increase the setting of H0F-08.
7. The servo drive/motor is faulty.	<p>Monitor running curve in Inovance servo commissioning software:</p> <p>Position reference, position feedback, speed reference, torque reference</p>	If position reference is not 0, but position feedback is always 0, replace servo drive/motor.

42. Er.B03: Electronic gear ratio setting exceeding limit

Cause:

Any electronic gear ratio exceeds limit: $0.001 \times \text{encoder resolution}/10000$, $4000 \times \text{encoder resolution}/10000$.

Cause	Confirming Methods	Corrective Action
Electronic gear ratio setting exceeds preceding limit.	If H05-02 = 0, check the ratios of H05-07/H05-09 and H05-11/H05-13 If H05-02 > 0, check the ratios of encoder resolution/H05-02, H05-07/H05-09 and H05-11/H05-13.	The ratios of encoder resolution / H05-02, H05-07/H05-09, and H05-11/H05-13 must be within preceding limit.
Parameter modification sequence is unreasonable.	When modifying electronic gear ration related parameters H05-02, H05-07/H05-09, and H05-11/H05-13, modifying sequence is unreasonable, which results in electronic gear ratio exceeding limit during calculation of electronic gear ratio.	Reset the fault or re-power on the system.

43. Er.B04: Fully closed-loop function parameter setting error

Cause:

When full closed-loop function is used and position reference source is internal position reference, switchover between internal encoder feedback and external encoder feedback is enabled.

Cause	Confirming Methods	Corrective Action
In full closed-loop mode, position reference source is internal position reference but internal encoder feedback and external encoder feedback is switched over.	Check whether H0F-00 = 2. Check whether position reference source is internal position reference: multi-position and position change on fly.	In full closed-loop mode, when position reference source is internal position reference, only external encoder feedback can be used. That is, H0F-00 can be set to 1 only.

44. Er.D03: CAN communication interrupted

Cause:

CAN communication times out.

Cause	Confirming Methods	Corrective Action
CAN communication is interrupted. The slave station is offline.	Check the CAN communication card indicator status of the master PLC. The ERR indicator of master PLC flashes at frequency 1 Hz and the ERR indicator of some slave PLCs keeps ON for a long period. (When using PLC background software, you can monitor D78xx in component monitoring table of the master. xx indicates station No. in decimal. If corresponding D78xx of some configured stations is 5, it indicates that a fault occurs on the slave PLC).	Check communication cable connection between the slave with ERR indicator ON for long time and master. Check communication baud rate (H0C-08) of the slave with ERR indicator ON for long time and adjust baud rate the same as that of the master.

Cause	Confirming Methods	Corrective Action
CAN communication is interrupted. The master station is offline.	Check the CAN communication card indicator status of the master PLC. The ERR indicator of all slave PLCs keeps ON for a long period. (When using PLC background software, you can monitor D78xx in the component monitoring table of the master. xx indicates station No. in decimal. If corresponding D78xx of all configured stations is 5, it indicates that a fault occurs on the master PLC.)	Check wirings of the master PLC.

8.2.3 Troubleshooting of Warnings

1. Er.110: Setting error of frequency-division pulse output

Cause:

When using the frequency-division output function of encoder (H05-38 = 0), setting of the number of frequency-division pulses of encoder does not match the threshold decided by encoder specification.

Cause	Confirming Methods	Corrective Action
The number of frequency-division pulses of encoder does not conform to the specification.	For incremental encoder, the number of frequency-division pulses cannot exceed encoder resolution. Resolution of 20-bit serial incremental encoder is 1048576 P/r. Resolution of 2500-PPR serial incremental encoder is 10000 P/r. For absolute encoder, the number of frequency-division pulses cannot exceed one fourth of encoder resolution.	Reset H05-17 (Encoder frequency-division pulses) correctly according to the specification.

2. Er.601: Homing timeout

Cause:

When using the Homing function (H05-30 = 1 to 5), home is not found within time set in H05-35.

Cause	Confirming Methods	Corrective Action
1. The home switch fails.	There is only high-speed searching and no low-speed searching during operation of returning to home. After high-speed searching of returning to home, the drive keeps reverse low-speed searching.	If hardware DI is used, check whether DI function FunIN.31: HomeSwitch (home switch) has been allocated to a DI and then check wiring of the DI. Make logic of the DI change manually and observe whether servo drive receives level change of the DI through H0B-03. If not, wiring of the DI is incorrect. If yes, a fault occurs during operation of returning to home. Please use the returning to home function correctly. If a virtual DI is used, check whether VDI is used correctly according to section 9.4.
2. The search time is too short.	Check whether time for Homing set in H05-35 is too short.	Increase H05-35.

Cause	Confirming Methods	Corrective Action
3. Speed of high-speed searching home switch signal is too small.	Check distance from initial position of returning to home to home switch. Then check whether H5-32 (speed of home switch signal at high-speed searching) is too small, resulting in too long time of finding home switch.	Increase H05-32.

3. Er.730: Encoder battery warning

Cause: Battery voltage of absolute encoder is lower than 3.0 V.

Cause	Confirming Methods	Corrective Action
Battery voltage of absolute encoder is lower than 3.0 V.	Measure battery voltage.	Replace a new battery with matching voltage.

4. Er.831: AI zero drift too large

Cause:

When input voltage of AI (AI1 and AI2) is 0 V, sampling voltage of servo drive is greater than 500 mV.

Cause	Confirming Methods	Corrective Action
1. AI wiring is incorrect or interference exists.	Check wiring by referring to correct wiring diagram.	Use shielded twisted pair cable and shorten cable length. Increase AI filter time constant: AI1 filter time constant: H03-51 AI2 filter time constant: H03-56
2. The servo drive is faulty.	Disconnect AI cable (input voltage is 0). Check whether AI sampling value in group H0B exceeds 500 mV.	If AI sampling value in group H0B exceeds 500 mV, replace the servo drive.

5. Er.900: DI emergency braking

Cause:

Logic of DI (including hardware DI and virtual DI) set for FunIN.34: EmergencyStop is valid.

Cause	Confirming Methods	Corrective Action
DI function FunIN.34: EmergencyStop is triggered.	Check whether logic of DI set for FunIN.34: EmergencyStop is valid.	Check the running mode and clear DI braking valid signal on the prerequisite of ensuring safety.

6. Er.909: Motor overload warning

Cause:

Accumulative heat of 60Z series 200 W and 400 W motor reaches the warning level.

Cause	Confirming Methods	Corrective Action
1. Wiring of motor and encoder is incorrect or poor.	Check wirings between servo drive, servo motor and encoder according to correct wiring diagram.	Connect wirings based on correct wiring diagram. Prefer to use the cable configured by Inovance as standard. When self-made cable is used, make and connect wirings according to hardware wiring guidance.
2. The load is too heavy. The motor keeps output of effective torque higher than rated torque for a long time.	Confirm overload characteristic of servo drive or servo motor. Check whether average load rate (H0B-12) is greater than 100.0% for long time.	Replace a large servo drive and matching servo motor. Reduce the load and increase acceleration/deceleration time.
3. Acceleration/deceleration is too frequent or load inertia is too large.	Calculate load inertia ratio or perform load inertia ratio auto-tuning. Then view H08-15 (load inertia ratio). Conform single running cycle when servo motor runs in circular.	Increase acceleration/deceleration time.
4. The gain is improper, causing too high rigidity.	Observe whether motor vibrates and generates noise during running.	Adjust the gain by referring to Chapter 6.
5. The servo drive or motor model is set incorrectly.	For IS620P series products, view serial encoder motor model in H00-05 and servo drive model in H01-02. For IS600P series products, view serial encoder motor model in H00-05 and servo drive model in H01-02.	View servo drive nameplate and set servo drive model (H01-02) correctly and replace matching servo motor according to section 1.3.
6. Locked-rotor occurs due to mechanical factors, resulting in very heavy load during running.	Check running reference and motor speed (H0B-00) by using Inovance servo commissioning software or operating panel. Running reference in the position control mode: H0B-13 (input reference pulse counter) Running reference in speed control: H0B-01 (speed reference) Running reference in torque control: H0B-02 (internal torque reference) Check running reference in corresponding mode is not 0 but the motor speed is 0.	Eliminate mechanical factors.
7. The servo drive is faulty.	Power off the servo drive and then power it on again.	If the fault persists after re-power-on, replace the servo drive.

7. Er.920: Regenerative resistor overload

Cause:

Accumulative heat of regenerative resistor is greater than the setting value.

Cause	Confirming Methods	Corrective Action
1. Wiring of external regenerative resistor is in poor connection, becomes loose or breaks.	Disconnect external regenerative resistor and measure whether resistance of the resistor is ∞ .	Replace a new external regenerative resistor and measure its resistance. If the resistance is consistent with nominal value, connect it between P _Ⓟ and C.
	Measure whether resistance between P _Ⓟ and C is ∞ .	Select a new cable and connect it between P _Ⓟ and C.
2. Jumper across terminals P _Ⓟ and D is shorted or disconnected when the internal regenerative resistor is used.	Measure whether resistance between P _Ⓟ and D is ∞ .	Select a new cable and connect it between P _Ⓟ and D.
3. Setting of H02-25 is incorrect when external regenerative resistor is used.	View setting value of H02-25.	Set H02-25 correctly according to section 4.2.
	Measure resistance of external regenerative resistor connected between P _Ⓟ and C. Check whether the resistance is too large by comparing it with the regenerative resistor specification table in section 5.1.4.	H02-25 = 1 (external regenerative resistor used, naturally ventilated) H02-25 = 2 (external regenerative resistor used, forcible cooling)
4. Resistance of the used external regenerative resistor is too large.	Check whether setting value of H02-27 is greater than resistance of external regenerative resistor connected between P _Ⓟ and C.	Select a proper regenerative resistor according to section 5.1.4.
5. H02-27 (resistance of external regenerative resistor) is larger than resistance of the used external regenerative resistor.		Set H02-27 (resistance of external regenerative resistor) consistent with the resistance of the selected external regenerative resistor.
6. Input voltage of main circuit exceeds specification.	Check whether input voltage of main circuit on servo drive side satisfies the following specification: 220 VAC drive: Valid value: 220 to 240 V Allowed error: -10% to 10% (198 to 264 V) 380 VAC drive: Valid value: 380 to 480 V Allowed error: -10% to 10% (342 to 528 V)	Replace power supply or adjust power voltage according to specification on the left.

Cause	Confirming Methods	Corrective Action
7. The load inertia is too large.	Perform inertia auto-tuning according to section 6.2 or calculate total inertia of machine according to mechanical parameters. Check whether actual load inertia ratio exceeds 30.	Select a large external regenerative resistor and set H02-26 (power of external regenerative resistor) consistent with actual value.
8. Speed is too high, and deceleration is not completed within required time. The regenerative resistor is in continuous deceleration status.	View speed curve of motor for cycle running and check whether motor is in deceleration status for a long period.	Select a large servo drive. If allowed, reduce the load. If allowed, increase acceleration/ deceleration time.
9. Capacity of servo drive or regenerative resistor is insufficient.	View single cycle speed curve of motor and calculate whether maximum braking energy can be absorbed completely.	If allowed, increase motor running cycle.
10. The servo drive is faulty.	-	Replace a new servo drive.

8. Er.922: Resistance of external braking resistor too small

Cause:

H02-27 (resistance of external regenerative resistor) is smaller than H02-21 (Allowed minimum value of regenerative resistor).

Cause	Confirming Methods	Corrective Action
When an external regenerative resistor is used (H02-25 = 1 or 2), resistance of the external regenerative resistor is smaller than minimum value required by servo drive.	Measure resistance of the external regenerative resistor between P _⊕ and C and check whether it is smaller than H02-21 (allowed minimum value of regenerative resistor).	If yes, connect an external regenerative resistor matching servo drive between P _⊕ and C and set H02-27 (resistance of external regenerative resistor) to resistance of the selected regenerative resistor. If not, set H02-27 to resistance of the selected regenerative resistor.

9. Er.939: Motor power cable breaking

Cause:

Actual phase current of motor is smaller than 10% of rated motor current, actual motor speed is small but internal torque reference is very large.

Cause	Confirming Methods	Corrective Action
Motor power cable breaking	Check whether difference between H0B-24 (phase current valid value) and H0B-02 (internal torque reference) reaches over 500%. Meanwhile, H0B-00 (actual motor speed) is smaller than one fourth of rated motor speed.	Check the motor power cable connection and reconnect wirings. If necessary, replace a new cable.

10. Er.941: Parameter modification taking effect only after re-power-on

Cause:

Modification of some parameters takes effect only after servo drive is powered on again. After these parameters are modified, servo drive reminds of re-power-on.

Cause	Confirming Methods	Corrective Action
Modify parameters, whose modification takes effect only after re-power-on.	Check whether you modify parameters, whose modification takes effect only after re-power-on.	Re-power on the servo system.

11. Er.942: Parameter storage too frequent

Cause:

The number of parameters that are being modified simultaneously exceeds 200.

Cause	Confirming Methods	Corrective Action
A great number of parameters are modified and stored frequently to EEPROM (H0C-13 = 1).	Check whether host controller performs frequent and fast parameter modification on servo drive.	Check the running mode. For the parameters that need not be stored in EEPROM, set H0C-13 to 0 before writing operation of host controller.

12. Er.950: Forward limit switch warning

Cause:

Logic of DI set for FunIN.14: P-OT (forward limit switch) is valid.

Cause	Confirming Methods	Corrective Action
Logic of DI set for FunIN.14: P-OT (forward limit switch) is valid.	<p>Check whether a parameter in group H03 is set for FunIN14 (P-OT).</p> <p>Check whether logic of corresponding DI is valid in H0B-03 (monitored DI states).</p>	Check the running mode. Send a reverse reference or rotate motor on the prerequisite of ensuring safety to make logic of the forward overshoot switch terminal invalid.

13. Er.952: Reverse limit switch warning

Cause:

Logic of DI set for FunIN.15: N-OT (reverse limit switch) is valid.

Cause	Confirming Methods	Corrective Action
Logic of DI set for FunIN.15: N-OT (reverse limit switch) is valid.	<p>Check whether a parameter in group H03 is set for FunIN15 (N-OT).</p> <p>Check whether logic of corresponding DI is valid in H0B-03 (monitored DI states).</p>	Check the running mode. Send a reverse reference or rotate motor on the prerequisite of ensuring safety to make logic of the reverse overshoot switch terminal invalid.

14. Er.980: Encoder internal fault

Cause:

Encoder algorithm error occurs.

Cause	Confirming Methods	Corrective Action
It is encoder internal fault	If the fault persists after you power on servo drive several times, it indicates that the encoder is faulty.	Replace servo motor.

15. Er.990: Power input phase loss warning

Cause:

Three-phase servo drive of 1 kW below is allowed to run under single-phase power but the fault and warning of power input phase loss (H0A-00) is enabled.

Cause	Confirming Methods	Corrective Action
When H0A-00 = 1 (allow faults and warnings at power input phase loss protection), three-phase servo drive (0.75 kW) (H01-02 = 5) can run under single-phase power. When single-phase power is connected, this warning is reported.	Check whether it is a three-phase servo drive allowed to run under single-phase power.	<p>If the warning persists when a three-phase servo drive is connected to three-phase power, troubleshoot it as Er.420 (power cable phase loss).</p> <p>If the warning persists when a three-phase servo drive is connected to single-phase power, set H0A-00 to 0.</p>

16. Er.994: CAN address conflict

Cause	Confirming Methods	Corrective Action
CAN address conflict occurs.	Check whether H0C-00 (servo shaft address) is allocated repeatedly.	Allocate servo shaft address of slaves and ensure that allocation of H0C-00 is not repeated.

8.2.4 Internal Faults

When any of the following fault occurs, contact Inovance for technical support.

- Er.602: Angle auto-tuning failure
- Er.220: Phase sequence incorrect
- Er.A40: Motor auto-tuning failure
- Er.111: Servo internal parameters abnormal



9 BUS Communication

9.1 Modbus Communication.....	456
9.1.1 Hardware Connection and EMC Notice.....	456
9.1.2 Modbus Communication Parameter Setting.....	460
9.1.3 Modbus Protocol.....	464
9.1.4 Modbus Communication Troubleshooting.....	470
9.2 CANlink Communication.....	473
9.2.1 Hardware Configuration.....	474
9.2.2 CANlink Communication Parameters Setting.....	474
9.2.3 CANlink Communication Troubleshooting.....	475
9.3 CANopen Communication.....	476
9.3.1 Hardware Configuration.....	477
9.3.2 CANopen Communication Parameters Setting.....	477
9.3.3 CANopen Communication Troubleshooting.....	478
9.4 VDI/VDO.....	479

Chapter 9 BUS Communication

9.1 Modbus Communication

The servo drive supports RS232 and RS485 communication. Users can modify and view parameters and monitor servo drive status on the host controller configured with the communication software. RS485 supports networking of single master and multiple slaves (servo drives). RS232 does not support networking of multiple servo drives.

9.1.1 Hardware Connection and EMC Notice

Hardware Connection

1) RS232 connection diagram

Figure 9-1 RS232 connection diagram

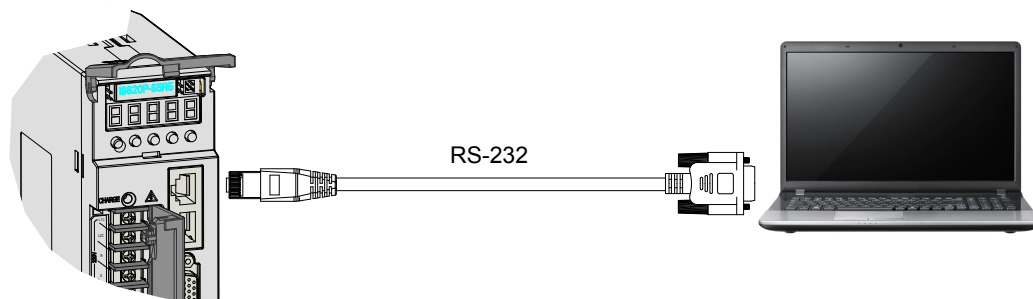

2) RS485 connection diagram

Figure 9-2 RS485 connection diagram

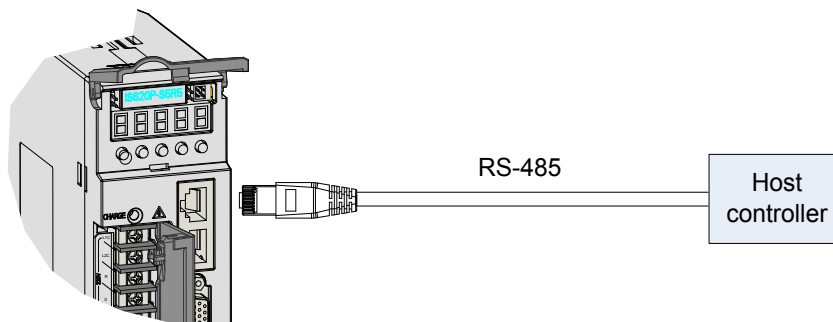

3) When there are a large number of nodes, the RS485 bus structure of hand-in-hand connection is recommended.

If branch connection is used, the cable length between the bus and a node is as short as possible; the recommended length is shorter than 3 m.

The star connection is forbidden.

The following figures show the common bus structures.

a. Hand-in-hand connection structure

Figure 9-3 Hand-in-hand connection structure

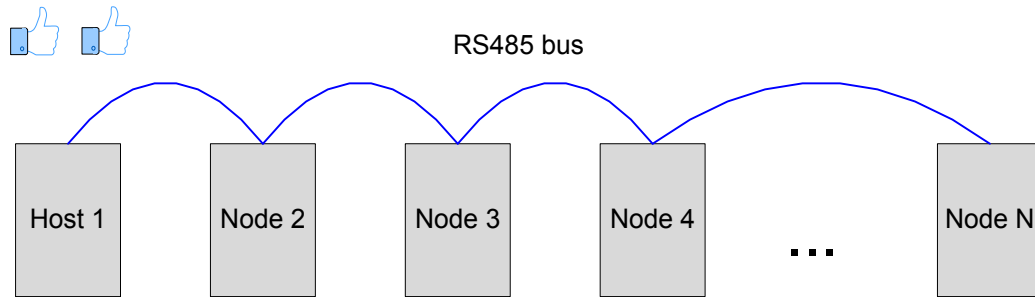

b. Branch connection structure

Figure 9-4 Branch connection structure

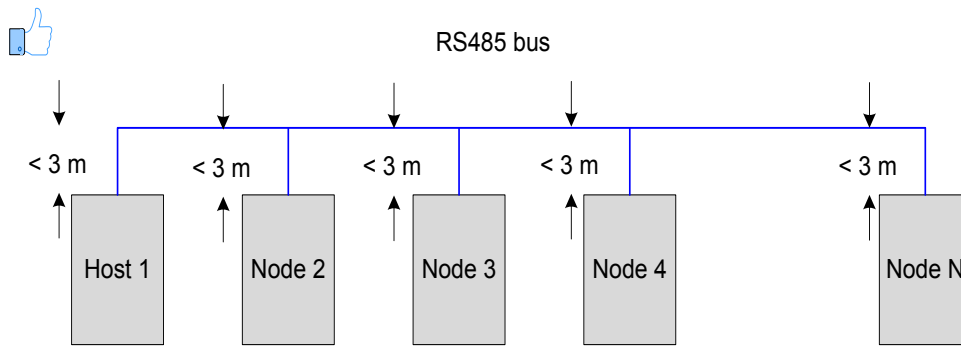

Branch connection: cable length not exceeding 3 m

c. Wrong structure: star connection structure

Figure 9-5 Star connection structure (wrong)

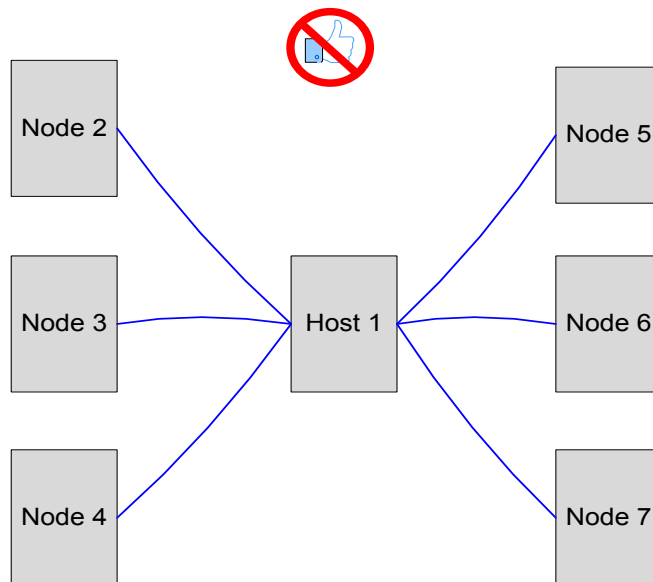

Note	<ol style="list-style-type: none"> 1. Connect the correct bias resistor and termination resistor. For details, refer to problem 1. 2. Use the twisted pair as the RS485 communication cable. 3. Use a third cable to connect the RS485 circuit reference ground GND. 4. If the shielded cable is used, it is recommended to connect both ends of the shield to PE. Do not connect either end to GND; otherwise, the terminal will be damaged. 5. Use the hand-in-hand connection. For details, refer to problem 3. 6. When using an extra PE cable to connect the PE terminals of all nodes, observe the EMC precautions. 7: The RS485 bus must be separated from other interference cables. See the EMC precautions.
-------------	--

EMC Notice

1) Field cabling requirement

Figure 9-6 Cabling diagram

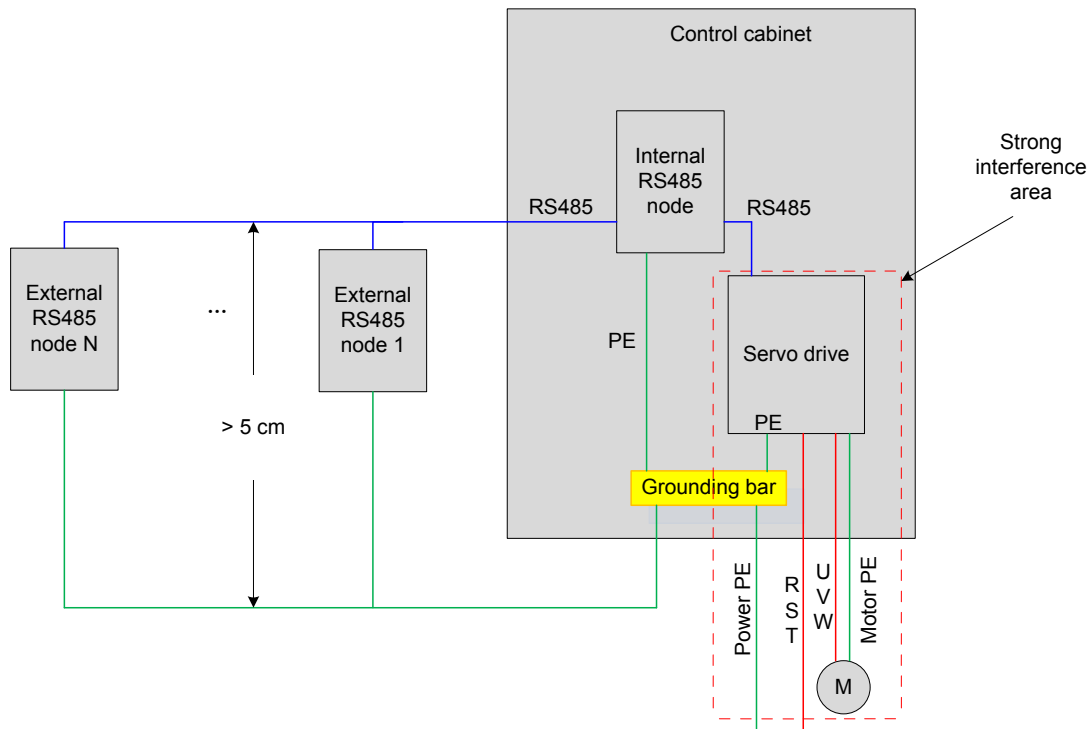

Note	<ol style="list-style-type: none"> 1. The interfering source must be isolated from the sensitive devices. 2. The interfering devices and cables are laid in a very small area, for example, close to the cable outlet.
-------------	--

2) PE cable connection requirements

Figure 9-7 PE cable connection diagram

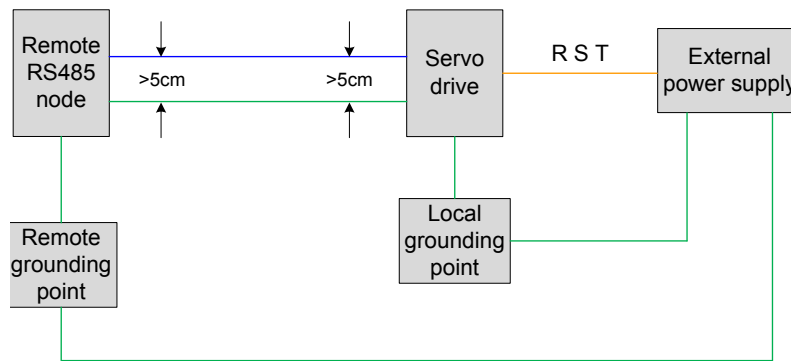

Note	<ol style="list-style-type: none"> 1. The PE cable must be thicker than the AWG12 cable. 2. The PE cable is connected to the grounding terminal of the node or the grounding bar in the cabinet where the node is installed. 3. The distance between the PE cable and the bus must be larger than 5 cm.
-------------	--

3) Cabling requirements

Figure 9-8 Cabling diagram

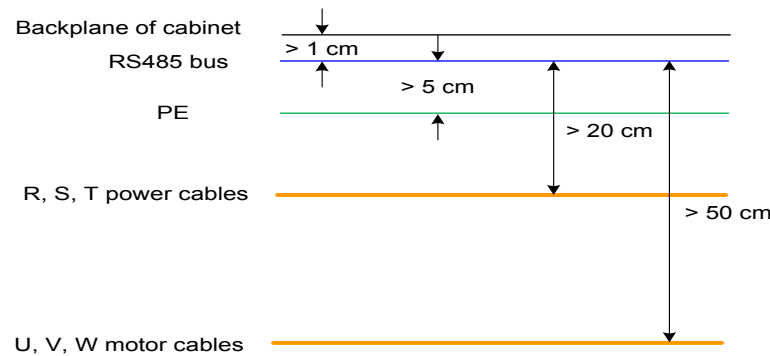

Note	<ol style="list-style-type: none"> 1. The distance between the RS485 bus and strong-current cables must be larger than 20 cm. 2. The distance between the RS485 bus and U, V, W motor cables must be larger than 50 cm. 3. The distance between the RS485 bus and grounding cable must be larger than 5 cm. 4. The distance between the RS485 bus and the backplane of the control cabinet must be larger than 1 cm.
-------------	--

RS485 Modbus Relationship Table

No.	Rate	Transmission Distance	Node Quantity	Wire Size
1	57.6 kbps	100 m	128	AWG26
2	19.2 kbps	1000 m	128	AWG26



RS485 supports connection of up to 32 servo drives. To connect more servo drives, an amplifier is required, which extends the number of servo drives networked to 247. If the host computer supports only RS232, use an RS232/RS485 converter.

9.1.2 Modbus Communication Parameter Setting

Figure 9-9 Flowchart of communication parameter setting

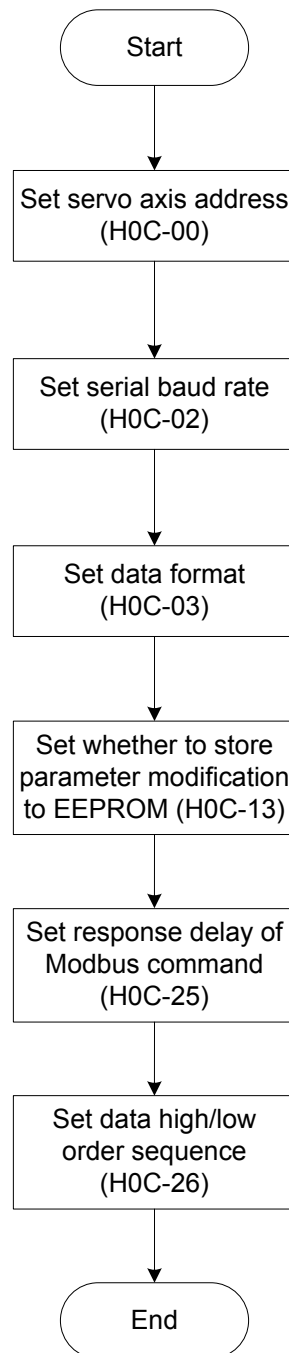

9

1) Set the axis address of the servo drive in H0C-00.

- 0: broadcast address.

The host controller writes all servo drives through the broadcast address; the servo drives act after receiving the frame with the broadcast address and do not return a response.

- 1 to 247: slave addresses

Each of the multiple servo drives networked must have a unique address; otherwise, communication abnormality or failure will occur.

2) Set the communication rate between the servo drive and the host controller in H0C-02.

The baud rate set in the servo drive must be the same as that in the host controller. Otherwise, communication will fail.

In the network of multiple servo drives, if the baud rate in a certain servo drive is different from that in the host controller, communication error will occur in the servo drive and communication with other servo drives will be affected.

3) Set the data check format between the servo drive and the host controller in H0C-03.

Two data check formats are supported, even check (H0C-03 = 1) and odd check (H0C-03 = 2). If H0C-03 = 0, no check is performed.

a. Even or odd check

Each frame actually includes 11 bits: 1 start bit, 6 data bits, 1 check bit, and 1 end bit.

10	9	8~1	0
End bit	Check bit	Data bit	Start bit

b. No check

If no check is used, the data frame has two formats.

Each frame actually includes 11 bits: 1 start bit, 8 data bits, 2 end bits.

10~9	8~1	0
End bit	Data bit	Start bit

Each frame actually includes 11 bits: 1 start bit, 8 data bits, 1 end bit.

10	9	8~1	0
Invalid bit	End bit	Data bit	Start bit

The data is hexadecimal.

Note	The host controller must use the preceding formats. Otherwise, communication with the servo drive fails.
-------------	--

4) Set whether to store function code modification via communication to EEPROM in H0C-13.

The servo drive can store function codes in real time (H0C-13 = 1). Modification of function codes is stored in EEPROM in real time, which implements retentive at power failure. Use this function with caution.

a. If a function code needs to be modified only once, enable real-time storage (H0C-13 = 1).

b. If the function code needs to be modified frequently, you are suggested to disable real-time storage (H0C-13 = 0). Otherwise, frequent writing EEPROM reduces its service life.

Note	<p>1. If EEPROM is frequently written in a certain period, the servo drive reports warning Er.942.</p> <p>2. After EEPROM is damage, other non-resettable faults will occur in the servo drive.</p>
-------------	---

5) Set the response delay of Modbus communication in H0C-25.

After receiving a command, the servo drive returns a response to the host controller through the delay in H0C-25.

6) Set the high/low order sequence of communication data in H0C-26.

The function code of servo drive is displayed as HXX-YY.

XX: function code group No., in hexadecimal

YY: offset within function code group, in decimal, converted into hexadecimal in the data frame

The function code communication address of the servo drive is 16-bit data, consisting of function code group No. (high 8 bits) and offset (low 8 bits).

If the data range is within -65536 and +65535, it is a 16-bit function code, occupying only one offset within function code group and only one address, not involving the data high/low order sequence.

For example, the communication address of H02-00 is 0x0200. If the data range is outside -65536 to +65535, it is 32-bit function code, occupying two consecutive offsets and two consecutive addresses. However, the communication address is determined by the address of the lower offset. The data high/low-order sequence must be set correctly. Otherwise, a data read/writing error will occur.

For example, function code H11-12 (1st displacement) occupies two consecutive offsets, H11-12 and H11-13; the communication address 0x110C of the lower offset H11-12 stores low 16 bits of the function code value, and the communication address 0x110D of the higher offset H11-13 stores high 16 bits of the function code value.

If "1st displacement" is preset to 0x40000000 (1073741824 in decimal), H11-12 must be set to 0x0000 and H11-13 must be set to 0x4000.

When a function code is written, the sequence of 0x0000 and 0x4000 in the communication frame is determined according to H0C-26 setting.

Note

1. The servo drive does not permit separate operation on high 16 bits of a 32-bit function code.
2. When modifying a function code via communication, pay attention to the setting range, unit, effective time, property, positive/negative hexadecimal conversion. Refer to the descriptions of parameters.



For the PLC/touchscreen of certain vendors, the register address for Modbus programming is the actual register address + 1. The reason is that the standard Modbus register start address is 1, but the register start address of these devices (for example, our servo drive) is actually 0. To solve compatibility, PLC/touchscreen vendors make the register address deducted by 1 during physical transmission. Pay attention to this during Modbus communication between such PLC/touchscreen and servo drive to ensure that function codes of the servo drive can be read/written correctly. For example, the register address read/written in programming is 0x0201, and the actual function code read/written is H02-00 rather than H02-01.

If you are unsure of whether a PLC/touchscreen's register address for Modbus programming is the actual one, select two consecutive function codes of different values, and use command 0x03 to read the larger one. If the function code value read is equal to the value of the smaller function code, it indicates that the register address for programming is equal to the actual register address + 1.

Relevant parameters:

Function Code	Parameter Name	Setting Range	Unit	Function	Property	Effective Time	Default
H0C-00	Servo axis address	1 to 247	-	Set the axis address of the servo drive.	During running	Immediate	0
H0C-02	Serial baud rate	0: 2400 1: 4800 2: 9600 3: 19200 4: 38400 5: 57600	Kbps	Set the communication rate between the servo drive and the host controller	During running	Immediate	5
H0C-03	Modbus data format	0: No check, 2 stop bits 1: Even parity check, 1 stop bit 2: Odd parity check, 1 stop bit 3: No check, 1 stop bit	-	Set the data check format between the servo drive and the host controller.	During running	Immediate	0
H0C-13	Update function code values written via communication to EEPROM	0: Not update 1: Update	-	Set whether to store the function codes written via communication to EEPROM.	During running	Immediate	0
H0C-25	Modbus response delay	0~5000	ms	Set the delay from the moment when the slave receives a command from the host controller to the moment when the slave returns a response.	During running	Immediate	1
H0C-26	Modbus communication data sequence	0: High 16 bits before low 16 bits 1: Low 16 bits before high 16 bits	-	Set the 32-bit data transmission format of Modbus communication.	During running	Immediate	1

9.1.3 Modbus Protocol

The function codes of the servo drive include two data lengths, 16 bits and 32 bits. Function codes can be read/written by using the Modbus-RTU protocol. The command codes during writing vary with the data length.

Activity	Command Code
Read 16/32-bit function code	0x03
Write 16-bit function code	0x06
Write 32-bit function code	0x10

Read Function Code: 0x03

Command code 0x03 in the Modbus-RTU protocol is used to read both 16-bit and 32-bit function codes.

Request frame format:

START	Equal to or larger than 3.5-character idle time, frame start
ADDR	Servo axis address 1 to 247 Note: 1 to 247 are decimals, and converted into hexadecimal when filled into ADDR.
CMD	Command code: 0x03
DATA[0]	Start function code group No. For example, "06" is the function code group No. in H06-11. Note: "06" is hexadecimal, and need not be converted when filled into DATA[0].
DATA[1]	Start offset within function code group. For example, "11" is the offset in H06-11. Note: "11" is decimal, and converted into hexadecimal 0x0B when filled into DATA[1].
DATA[2]	Read number of function codes (high 8 bits), hexadecimal
DATA[3]	Read number of function codes (low 8 bits), hexadecimal
CRCL	CRC valid byte (low 8 bits)
CRCH	CRC valid byte (high 8 bits)
END	Equal to or larger than 3.5-character idle time, frame end

Response frame format:

START	Equal to or larger than 3.5-character idle time, frame start
ADDR	Servo axis address, hexadecimal
CMD	Command code: 0x03
DATALENGTH	Number of bytes of function code, equal to number of read function codes N*2
DATA[0]	Start function code value, high 8 bits
DATA[1]	Start function code value, low 8 bits
DATA[...]	
DATA[N*2-1]	End function code value, low 8 bits
CRCL	CRC low valid byte
CRCH	CRC high valid byte
END	Equal to or larger than 3.5-character idle time, frame end

In the Modbus-RTU protocol, command code 0x06 is used to write 16-bit function code and command code 0x10 is used to write 32-bit function code.

Write 16-bit Function Code (0x06)



CAUTION

Do not use 0x06 to write 32-bit function code. Otherwise, unexpected errors will occur.

Request frame format:

START	Equal to or larger than 3.5-character idle time, frame start
ADDR	Servo axis address 1 to 247 Note: 1 to 247 are decimals, and converted into hexadecimal when filled into ADDR.
CMD	Command code: 0x06
DATA[0]	Function code group No. to be written. For example, "06" is the function code group No. in H06-11. Note: "06" is hexadecimal, and need not be converted when filled into DATA[0].
DATA[1]	Function code offset to be written. For example, "11" is the offset in H06-11. Note: "11" is decimal, and converted into hexadecimal 0x0B when filled into DATA[1].
DATA[2]	High byte of data to be written, hexadecimal
DATA[3]	Low byte of data to be written, hexadecimal
CRCL	CRC low valid byte
CRCH	CRC high valid byte
END	Equal to or larger than 3.5-character idle time, frame end

Response frame format:

START	Equal to or larger than 3.5-character idle time, frame start
ADDR	Servo axis address, hexadecimal
CMD	Command code: 0x06
DATA[0]	Function code group No. to be written. For example, it is "0x06" for H06-11.
DATA[1]	Function code offset to be written. For example, it is "0x0B" for H06-11.
DATA[2]	High byte of data to be written, hexadecimal
DATA[3]	Low byte of data to be written, hexadecimal
CRCL	CRC low valid byte
CRCH	CRC high valid byte
END	Equal to or larger than 3.5-character idle time, frame end

Write 32-bit Function Code (0x10)



CAUTION

Do not use 0x10 to write 16-bit function code. Otherwise, unexpected errors will occur.

Request frame format:

START	Equal to or larger than 3.5-character idle time, frame start
-------	--

ADDR	Servo axis address 1 to 247 Note: 1 to 247 are decimals, and converted into hexadecimal when filled into ADDR.
CMD	Command code: 0x10
DATA[0]	Function code group No. to be written. For example, it is "11" for H11-12. Note: "11" is hexadecimal, and need not be converted when filled into DATA[0].
DATA[1]	Function code offset to be written. For example, it is "12" for H11-12. Note: "12" is decimal, and converted into hexadecimal 0x0C when filled into DATA[1].
DATA[2]	High 8 bits M(H) of number of function codes; the length of a 32-bit function code is 2.
DATA[3]	Low 8 bits M(L) of number of function codes
DATA[4]	Number of bytes M*2 corresponding to number of function codes For example, for H05-07, DATA[4] is H04.
DATA[5]	High 8 bits of start function code to be written, hexadecimal
DATA[6]	Low 8 bits of start function code to be written, hexadecimal
DATA[7]	High 8 bits of start function code offset to be written + 1, hexadecimal
DATA[8]	Low 8 bits of start function code offset to be written + 1, hexadecimal
CRCL	CRC low valid byte
CRCH	CRC high valid byte
END	Equal to or larger than 3.5-character idle time, frame end

Response frame format:

START	Equal to or larger than 3.5-character idle time, frame start
ADDR	Servo axis address, hexadecimal
CMD	Command code: 0x10
DATA[0]	Function code group No. to be written. For example, it is "0x11" for H11-12.
DATA[1]	Function code offset to be written. For example, it is "0x0C" for H11-12.
DATA[2]	High 8 bits of number of function codes to be written
DATA[3]	Low 8 bits of number of function codes to be written
CRCL	CRC low valid byte
CRCH	CRC high valid byte
END	Equal to or larger than 3.5-character idle time, frame end

Error Response Frame

Error frame response format:

START	Equal to or larger than 3.5-character idle time, frame start
ADDR	Servo axis address, hexadecimal
CMD	Command Code + 0x80
DATA[0]~[3]	DATA error code
CRCL	CRC low valid byte
CRCH	CRC high valid byte
END	Equal to or larger than 3.5-character idle time, frame end

Error code:

Error code	Code description
0x0001	Illegal command code
0x0002	Illegal data address
0x0003	Illegal data
0x0004	Slave device fault

Communication Example (H0C-26 = 0)

1) Master request frame

01	03	02	02	00	02	CRCL	CRCH
----	----	----	----	----	----	------	------

The request frame means that the master reads data of 0x0002 word length from the register with start function code H02-02 in the servo drive of axis address 01.

Slave response frame

01	03	04	00	01	00	00	CRCL	CRCH
----	----	----	----	----	----	----	------	------

The response frame means that the slave returns data of 2 word length (4 bytes), and the data content is 0x0001, 0x0000.

If the slave response frame is:

01	83	02	CRCL	CRCH
----	----	----	------	------

The response frame means that a communication error occurs, and the error code is 0x02; 0x83 indicates the error.

2) Master request frame

01	06	02	02	00	01	CRCL	CRCH
----	----	----	----	----	----	------	------

The request frame means that the master writes 0x0001 to function code H02-02 in the servo drive of axis address 01.

Slave response frame

01	06	02	02	00	01	CRCL	CRCH
----	----	----	----	----	----	------	------

The response frame means that the master writes function code successfully.

If the slave response frame is:

01	86	02	CRCL	CRCH
----	----	----	------	------

The response frame means that a communication error occurs, and the error code is 0x02; 0x86 indicates the error.

3) Read 32-bit function code H05-07

Master request frame

01	03	05	07	00	02	CRCL	CRCH
----	----	----	----	----	----	------	------

Slave response frame

01	03	04	00	01	00	00	CRCL	CRCH
----	----	----	----	----	----	----	------	------

The response frame means that the value of function code H05-07 is 0x00000001.

Addressing of 32-bit Function Code

When 32-bit function codes are read/written via Modbus, the communication address is the address of the lower offset, and operation is performed on both the two function code numbers.

For example, the Modbus command for reading H11-12 (1st displacement) is:

Servo axis address	03	11	0C	00	02	CRCL	CRCH
--------------------	----	----	----	----	----	------	------

If it is known that "1st displacement" is 0x40000000 (1073741824 in decimal):

H0C-26 = 1 (Low 16 bits before high 16 bits), then the response frame is:

Servo axis address	03	04	00	00	40	00	CRCL	CRCH
--------------------	----	----	----	----	----	----	------	------

H0C-26 = 0 (High 16 bits before low 16 bits), then the response frame is:

Servo axis address	03	04	40	00	00	00	CRCL	CRCH
--------------------	----	----	----	----	----	----	------	------

For example, the Modbus command for writing 0x12345678 to H11-12 (1st displacement) is:

H0C-26 = 1 (Low 16 bits before high 16 bits)

Servo axis address	10	11	0C	00	02	04	56	78	12	34	CRCL	CRCH
--------------------	----	----	----	----	----	----	----	----	----	----	------	------

H0C-26 = 0 (High 16 bits before low 16 bits)

Servo axis address	10	11	0C	00	02	04	12	34	56	78	CRCL	CRCH
--------------------	----	----	----	----	----	----	----	----	----	----	------	------

For example, to write 0x00100000 (1048576 in decimal) to 32-bit function code H05-07:

If H0C-26 = 0 (High 16 bits before low 16 bits), then the response frame is:

01	10	05	07	00	02	04	00	00	00	10	CRCL	CRCH
----	----	----	----	----	----	----	----	----	----	----	------	------

CRC Check

The host controller and servo drive must use the same CRC algorithm. Otherwise, a CRC error will occur. The servo drive uses 16-bit CRC with low byte before high byte. The CRC function is as follows:

```
uint16 COMM_CrcValueCalc(const uint16 *data, uint16 length)
```

```
{
```

```
    uint16 crcValue = 0xffff;
```

```
    int16 i;
```

```
    while (length--)
```

```

{
    crcValue ^= *data++;
    for (i = 0; i < 8; i++)
    {
        if (crcValue & 0x0001)
        {
            crcValue = (crcValue >> 1) ^ 0xA001;
        }
        else
        {
            crcValue = crcValue >> 1;
        }
    }
}
return (crcValue);
}

```

Expression of Signed Hexadecimal

When signed function codes (16-bit and 32-bit) are written, the pre-written data needs to be converted into hexadecimal.

1) 16-bit function code

- a. Data is positive or 0: complement = true form
- b. Data is negative: complement = $0xFFFF - \text{complement of data absolute value} + 0x0001$

Example:

16-bit signed positive +100: the true form is 0x0064, and the complement is also 0x0064.

16-bit signed negative -100, the hexadecimal complement is: $0xFFFF - 0x0064 + 0x0001 = FF9C$

2) 32-bit function code

- a. Data is positive or 0: complement = true form
- b. Data is negative: complement = $0xFFFFFFFF - \text{complement of data absolute value} + 0x00000001$

Example:

32-bit signed positive +100: the true form is 0x00000064, and the complement is also 0x00000064.

32-bit signed negative -100, the hexadecimal complement is: $0xFFFFFFFF - 0x00000064 + 0x00000001 = FFFFFFF9C$.

9.1.4 Modbus Communication Troubleshooting

Problem 1: Termination resistor connection

Figure 9-10 Correct termination resistor connection diagram

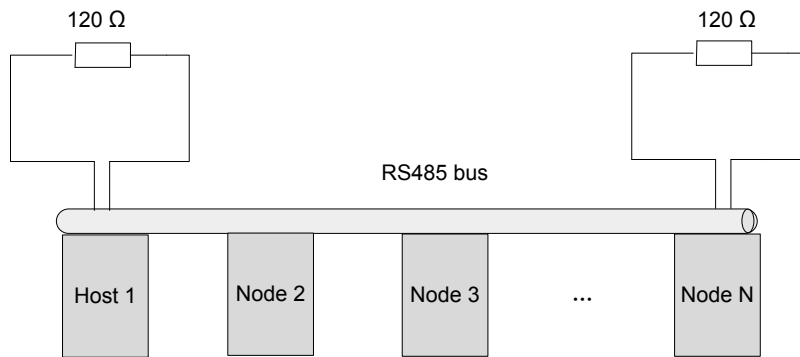

Note	
-------------	--

Note	<p>1. The termination resistor can be connected only at two ends of the bus.</p> <p>2. The master station must be arranged at one end of the bus.</p> <p>3. When the resistance of the RS485 bus measured by the multimeter is about 60 Ω (all devices must power off during measurement), the bus is normal. If the measured resistance is lower than 50 Ω, check two ends of the bus, and check whether another resistor is added; if yes, disconnect this one. If the measured resistance is 0 Ω, check whether short circuit exists or a node is damaged.</p>
-------------	---

Problem 2: Correct wiring method (for nodes without GND terminal)

Figure 9-11 Wiring diagram for nodes without GND terminal

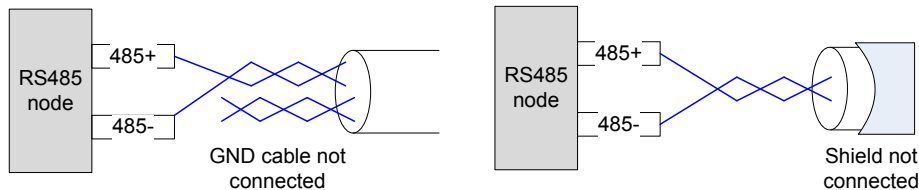

- Method 1: Check whether there is reference ground used by the RS485 circuit on other terminals of this node; if yes, connect GND to this reference ground. Note that the shield must not be connected to the reference ground; otherwise, the RS485 port will be damaged.
- Method 2: Check whether there is reference ground used by the RS485 circuit on the board of this node; if yes, connect GND to this reference ground. Note that the shield must not be connected to the reference ground; otherwise, the RS485 port will be damaged.
- Method 3: If the reference ground of the RS485 circuit cannot be found, leave the GND cable unconnected and ensure that the PE cable is connected reliably.
- Method 4: When there are not many nodes, connect a filter capacitor between 485+ and 485-.

Problem 3: Correct multi-node connection mode

Figure 9-12 Multi-node connection mode diagram

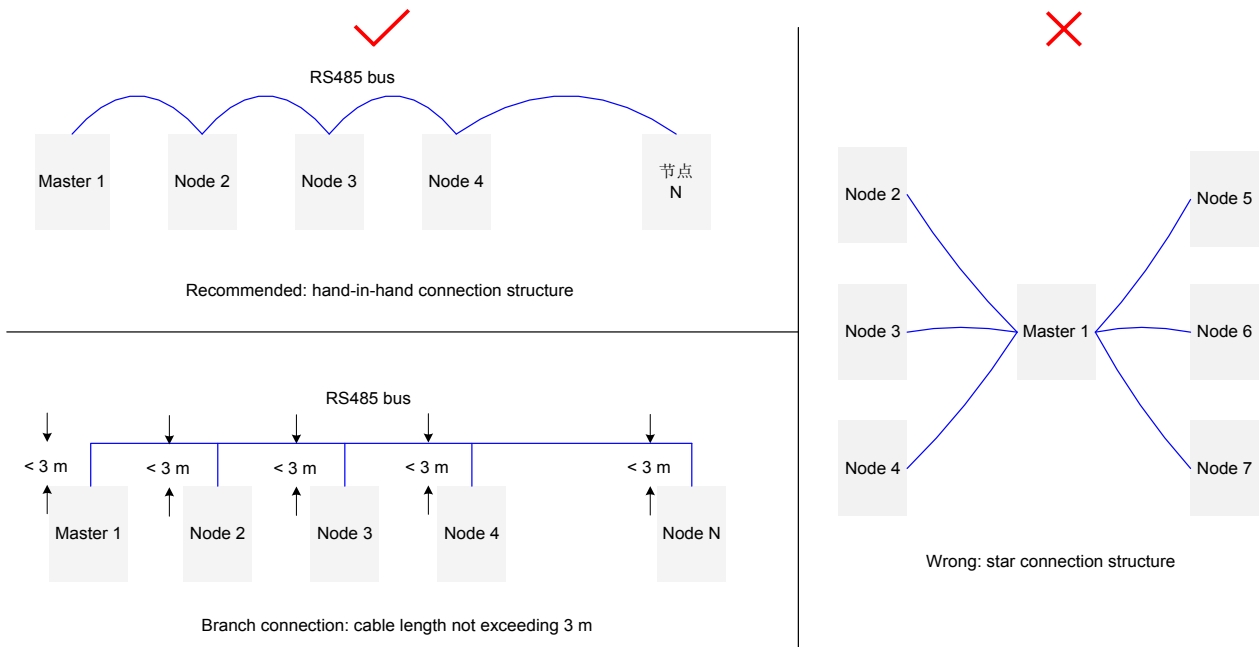

Problem 4: Suppressing interference from external system

Figure 9-13 Diagram of suppressing external interference

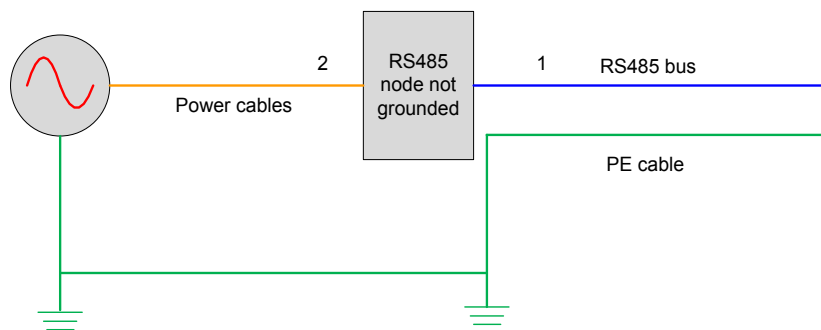

- Method 1: It is recommended that the magnetic ring is added at position 1, which can effectively suppress external interference.
- Method 2: Adding the magnetic ring at position 2 can also suppress external interference.

Problem 5: Suppressing drive interference

Figure 9-14 Diagram of suppressing drive interference

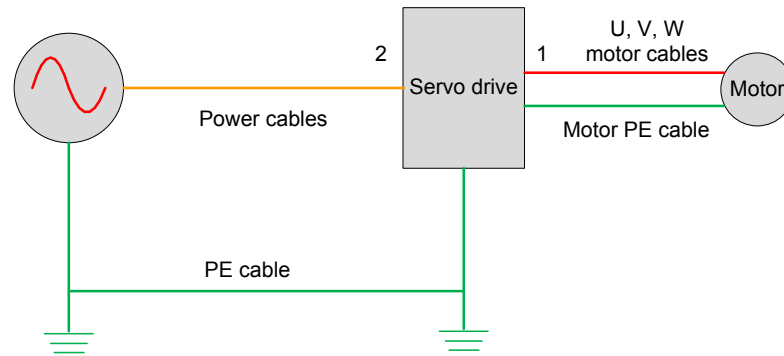

- Method 1: The recommended method is to add a filter magnetic ring at position 1, with the U, V, W cables (not including the PE cable) passing through the magnetic ring and winding three coils. This method has the best effect.
- Method 2: The second method is to add a filter magnetic ring at position 2, with the U, V, W cables (not including the PE cable) passing through the magnetic ring and winding three coils.

The following figure shows the problem locating flowchart.

Figure 9-15 RS485 communication problem locating flowchart

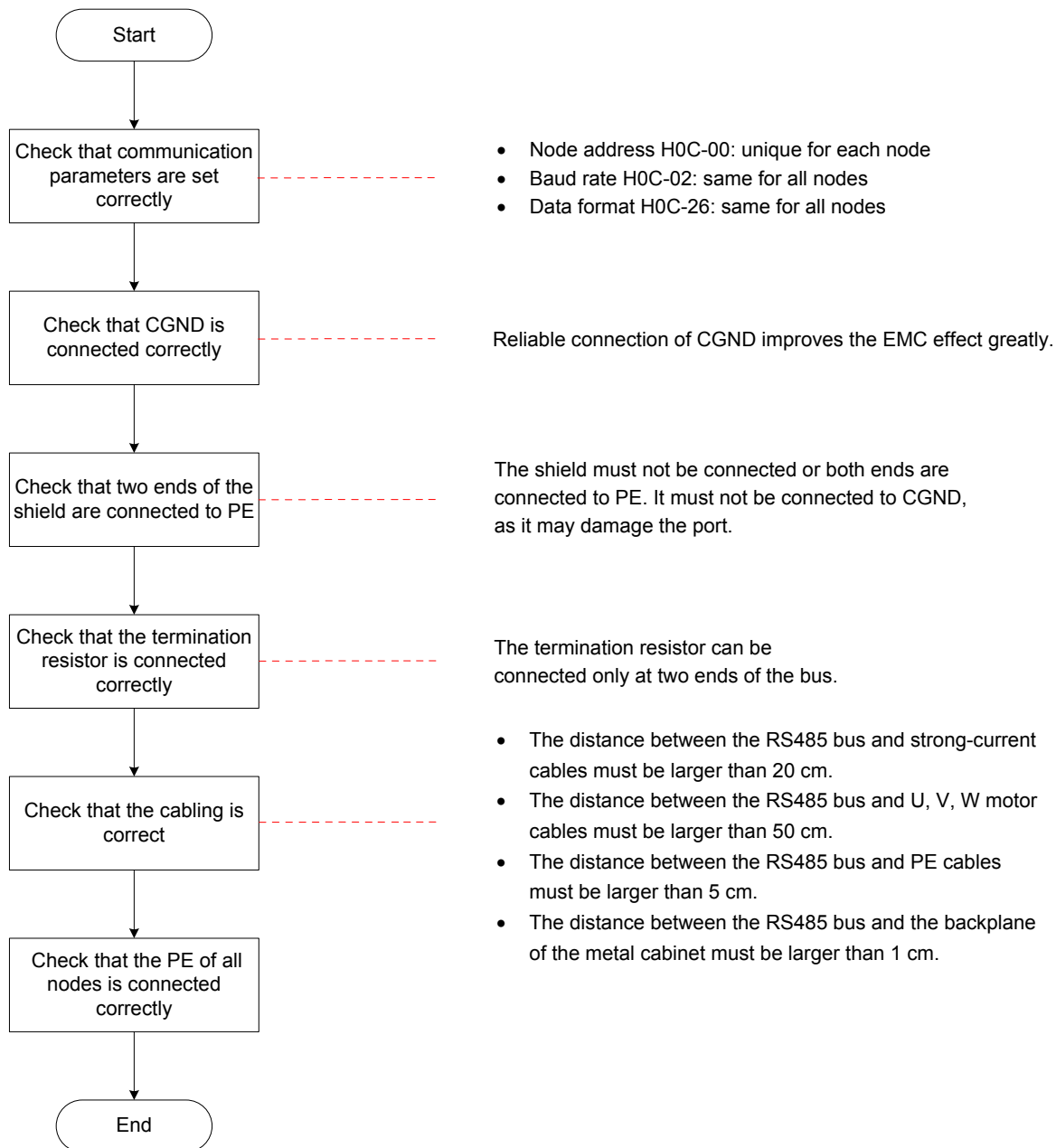

9.2 CANlink Communication

CANlink is a communication protocol developed by Inova Automation for embedded systems used in automation. In terms of the OSI model, CANlink implements the layers above and including the network layer. The lower level protocol implementing the data link and physical layers is usually Controller Area Network (CAN). The communication protocols have support for network management, device monitoring and communication between nodes.

CANlink supports Master/Slave mode, IS620P only supports Slave mode, it supports only one master node in the network, the address of master/slave node is 1~63 and different.

9.2.1 Hardware Configuration

Wiring

Figure 9-16 CANlink wiring diagram

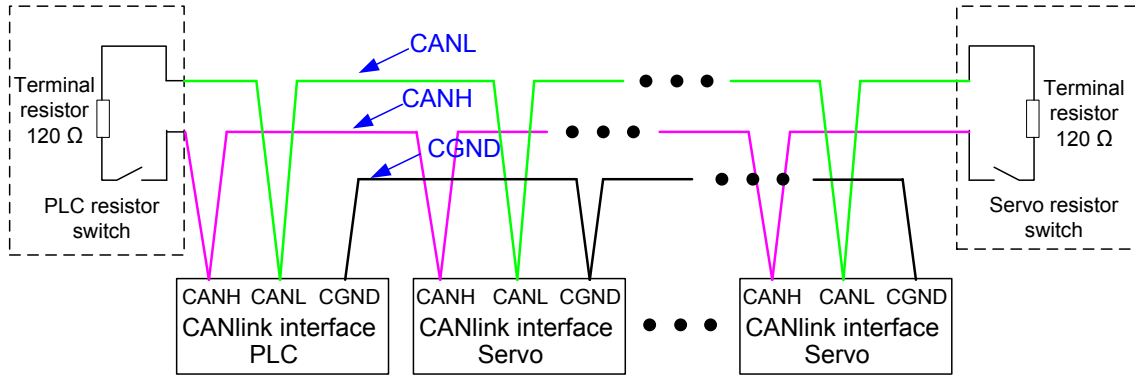

CANlink Relationship Table

Baud Rate (Kbps)	Max. Distance (m)	Cable Size (mm ²)	Max. Nodes
1000	20	≥ 0.3	18
500	80	≥ 0.3	62
250	150	≥ 0.3	62
125	300	≥ 0.5	62
100	500	≥ 0.5	62
50	1000	≥ 0.7	62

Note Above is based on standard shielded twisted pair.

9.2.2 CANlink Communication Parameters Setting

Function Code	Parameter Name	Setting Range	Function	Property	Effective Time	Default
H0C-00	Servo axis address	1 to 247	It sets the axis address of the servo drive. Each of the multiple servo drives networked must have a unique address; otherwise, communication abnormality or failure will occur.	During running	Immediate	1

Function Code	Parameter Name	Setting Range	Function	Property	Effective Time	Default
H0C-08	CAN communication rate	0 to 7	<p>It sets the CAN (CANlink or CANopen) communication rate between the servo drive and the host controller.</p> <p>0: 20 K 1: 50 K 2: 100 K 3: 125 K 4: 250 K 5: 500 K 6: 1 M 7: 1 M</p> <p>The communication rate set in the servo drive must be the same as that in the host controller. Otherwise, communication will fail.</p>	During running	Immediate	5
H0C-13	Update function code values written via communication to EEPROM	0 to 1	<p>It sets whether to store the function codes written via communication to EEPROM.</p> <p>0: Not update the function codes written via communication to EEPROM 1: Update the function codes written via communication to EEPROM, except groups H0B and H0D</p>			

9.2.3 CANlink Communication Troubleshooting

Er.D03: CAN communication interrupted

Cause:

CAN communication times out.

Cause	Confirming Methods	Corrective Action
<p>CAN communication is interrupted.</p> <p>The slave station is offline.</p>	<p>Check the CAN communication card indicator status of the master PLC.</p> <p>The ERR indicator of master PLC flashes at frequency 1 Hz and the ERR indicator of some slave PLCs keeps ON for a long period.</p> <p>(When using PLC background software, you can monitor D78xx in component monitoring table of the master. xx indicates station No. in decimal. If corresponding D78xx of some configured stations is 5, it indicates that a fault occurs on the slave PLC).</p>	<p>Check communication cable connection between the slave with ERR indicator ON for long time and master.</p> <p>Check communication baud rate (H0C-08) of the slave with ERR indicator ON for long time and adjust baud rate the same as that of the master.</p>

Cause	Confirming Methods	Corrective Action
CAN communication is interrupted. The master station is offline.	Check the CAN communication card indicator status of the master PLC. The ERR indicator of all slave PLCs keeps ON for a long period. (When using PLC background software, you can monitor D78xx in the component monitoring table of the master. xx indicates station No. in decimal. If corresponding D78xx of all configured stations is 5, it indicates that a fault occurs on the master PLC.)	Check wirings of the master PLC.

Er.994: CAN address conflict

Cause	Confirming Methods	Corrective Action
CAN address conflict occurs.	Check whether H0C-00 (servo shaft address) is allocated repeatedly.	Allocate servo shaft address of slaves and ensure that allocation of H0C-00 is not repeated.

9.3 CANopen Communication

CANopen is a communication protocol and device profile specification for embedded systems used in automation. In terms of the OSI model, CANopen implements the layers above and including the network layer. The CANopen standard consists of an addressing scheme, several small communication protocols and an application layer defined by a device profile.

The communication protocols have support for network management, device monitoring and communication between nodes, including a simple transport layer for message segmentation/desegmentation. The lower level protocol implementing the data link and physical layers is usually Controller Area Network (CAN). CANopen supports Master/Slave mode, the IS620P only supports Slave mode, It supports only one master node in the network, the address of master/slave node is 1~63 and different.

9.3.1 Hardware Configuration

Wiring

Figure 9-17 CANopen wiring diagram

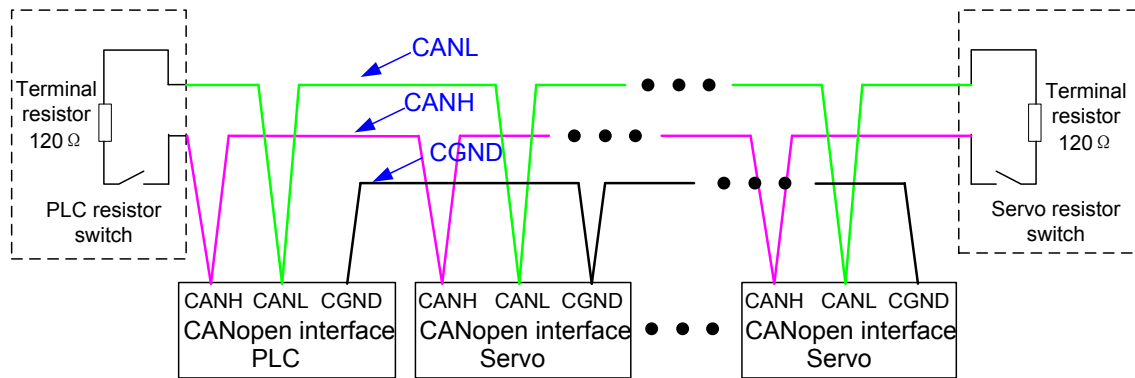

CANopen Relationship Table

Baud Rate (Kbps)	Max. Distance (m)	Cable Size (mm ²)	Max. Nodes
1000	20	≥0.3	18
500	80	≥0.3	62
250	150	≥0.3	62
125	300	≥0.5	62
100	500	≥0.5	62
50	1000	≥ 0.7	62

Note Above is based on standard shielded twisted pair.

9.3.2 CANopen Communication Parameters Setting

Function Code	Parameter Name	Setting Range	Function	Property	Effective Time	Default
H02-00	Control mode selection	0: Speed mode 1: Position mode 2: Torque mode 3: Torque mode/ Speed mode 4: Speed mode/ Position mode 5: Torque mode/ Position mode 6: Torque mode/ Speed mode/ Position mode	Set the control mode of the servo drive.	At stop	Immediate	1

Function Code	Parameter Name	Setting Range	Function	Property	Effective Time	Default
H0C-00	Servo axis address	1 to 247	It sets the axis address of the servo drive. Each of the multiple servo drives networked must have a unique address; otherwise, communication abnormality or failure will occur.	During running	Immediate	1
H0C-08	CAN communication rate	0 to 7	It sets the CAN (CANlink or CANopen) communication rate between the servo drive and the host controller. 0: 20 K 1: 50 K 2: 100 K 3: 125 K 4: 250 K 5: 500 K 6: 1 M 7: 1 M The communication rate set in the servo drive must be the same as that in the host controller. Otherwise, communication will fail.	During running	Immediate	5
H0C-13	Update function code values written via communication to EEPROM	0 to 1	It sets whether to store the function codes written via communication to EEPROM. 0: Not update 1: Update function code parameters 2: Update 402 parameters 3: Update all parameters	During running	Immediate	1

9.3.3 CANopen Communication Troubleshooting

Fault code	Fault Name	Cause	Corrective Action
Er.D04	Node protection or heartbeat timeout	The configuration time or node protection time for the slave is reached.	Check whether all CAN nodes are online or whether CANopen configuration is correct. Reset the node or communication.

Fault code	Fault Name	Cause	Corrective Action
Er.D05	NMT initialization at motor energized	The the network management system (NMT) initialization frame is received when the motor is energized.	Reset the NMT node. The polarity output is inhibited when the NMT is being changed.
Er.D06	NMT stop at motor energized	The network management system (NMT) stop frame is received when the motor is energized.	Reset the NMT node. The polarity output is inhibited when the NMT is being changed.
Er.D07	CANopen network disconnected	There are too many errors.	Check the CANopen network, and restore the connection.
Er.D08	PDO transmission length error	The PDO transmission length is different from the configured mapping length.	Re-configure the PDO, and reset the node or communication.
Er.D09	Software position upper/lower setting incorrect	The lower limit of the software position is larger than the upper limit.	Set 0x607D correctly, and ensure: 607D-1h < 607D-2h
Er.D10	Home offset setting incorrect	The home offset is outside the software position upper/lower.	Set 607D and 607C correctly, ensure: 607C > (607D-1h) 607C < (607D-2h)
Er.D11	Synchronization cycle error excessive	The synchronization cycle exceeds 1/4 of the setting value.	Check the 60C2-1h and 60C2-2h setting, and check that the synchronization cycle parameters have been set correctly. Check that the synchronization cycle in the host controller has been set correctly and is consistent with the 60C2h setting. Check wiring between the master and the slaves.

9.4 VDI/VDO

1) Virtual digital input (VDI) terminal

VDI is similar to hardware DI, and can be allocated with the DI function. A total of 16 VDIs are supported.



CAUTION

If a VDC is allocated with the same function (not 0) as a DI in group H03, the servo drive reports Er.130.

The following figure takes the operation of allocating FunIN.1: S-ON to a VDI as an example to describe the VDI use procedure.

Figure 9-18 VDI use flowchart

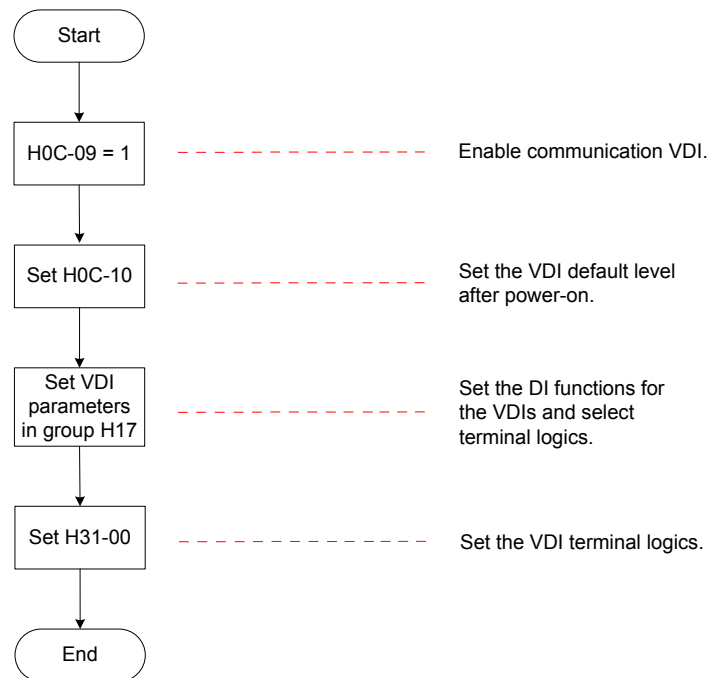

At power-on for the first time, the VDI terminal logic is determined by H0C-10 (VDI default value after power-on). Then, it is determined by H31-00 (VDI virtual level set via communication).

H0C-10 value displayed on the keypad is decimal, and H31-00 is not displayed on the keypad. In the converted binary value of H0C-10 (H31-00), bit(n) = 1 indicates that terminal VDI(n+1) logic is 1, and bit(n) = 0 indicates that terminal VDI(n+1) logic is 0.



The VDIx terminal logic "0" indicates high level valid and "1" indicates edge valid.

Relevant parameters:

Function Code	Parameter Name	Setting Range	Function	Property	Effective Time	Default
H0C-09	Communication VDI	0 to 1	Set whether to use the VDI.	At stop	Immediate	0
H0C-10	VDI default value after power-on	0 to 65535	Set the VDI default value after power-on.	At stop	Power-on again	0
H31-00	VDI virtual level set via communication	Bit0: VDI1 virtual level Bit15: VDI16 virtual level	Set the VDI terminal logic.	During running	Immediate	-

9

2) Virtual digital output (VDO) terminal

VDO is similar to hardware DO, and can be allocated with the DO function. A total of 16 VDOs are supported.

Use the VDO according to the following procedure:

Figure 9-19 VDO use flowchart

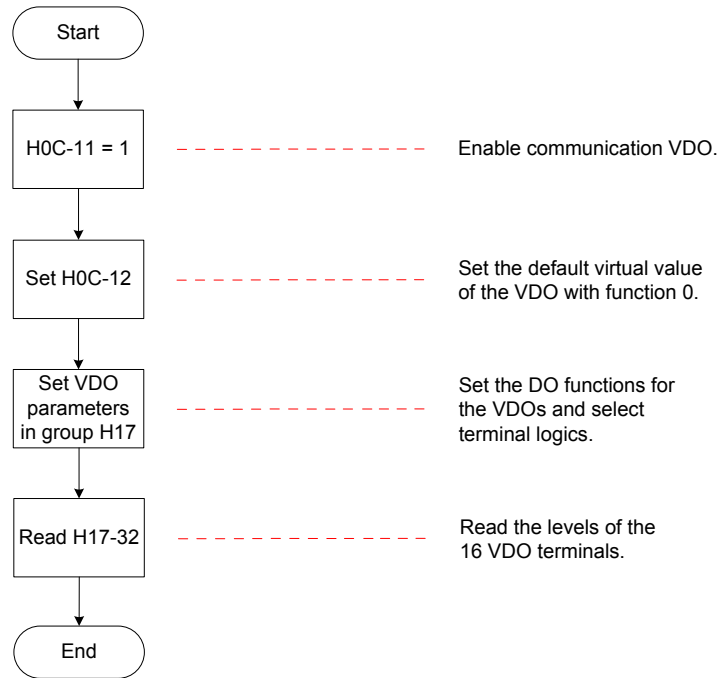

H0C-12 (H17-32) value displayed on the keypad is hexadecimal. In the converted binary value of H0C-12 (H17-32), bit(n) = 1 indicates that terminal VDO(n+1) logic is 1, and bit(n) = 0 indicates that terminal VDO(n+1) logic is 0. It is recommended that the VDO logic levels are opposite to H0C-12.



CAUTION The VDOx terminal logic "0" indicates high level valid and "1" indicates low level valid.

Relevant parameters:

Function Code	Parameter Name	Setting Range	Function	Property	Effective Time	Default
H0C-11	Communication VDO	0 to 1	Set whether to use the VDO.	At stop	Immediate	0
H0C-12	Default level of VDO allocated with function 0	0 to 65535	Sets the default virtual level of the VDO allocated with function 0 (invalid).	At stop	Immediate	0
H17-32	VDO virtual level	Bit0: VDO1 virtual level Bit15: VDO16 virtual level	Display the VDO virtual level.	At display	-	0



10 Appendixes

10.1 Cable Specification	484
10.2 Mounting Dimensions of Servo Motor	486
10.3 Physical Appearance and Mounting Dimensions of Servo Drive	500
10.4 Parameter Table.....	500
10.5 Version Record.....	551

Chapter 10 Appendixes

10.1 Cable Specification

Table 10-1 Physical appearance of cables for servo motor and servo drive

Cable Name	Cable Model	Cable Length (mm)	Cable Appearance
Servo motor main circuit cable	S6-L-M00-3.0	3000	
	S6-L-M00-5.0	5000	
	S6-L-M00-10.0	10000	
	S6-L-M11-3.0	3000	
	S6-L-M11-5.0	5000	
	S6-L-M11-10.0	10000	
	S6-L-M12-3.0	3000	
	S6-L-M12-5.0	5000	
	S6-L-M12-10.0	10000	
	S6-L-M22-3.0	3000	
	S6-L-M22-5.0	5000	
	S6-L-M22-10.0	10000	
	S6-L-B00-3.0	3000	
	S6-L-B00-5.0	5000	
	S6-L-B00-10.0	10000	
	S6-L-B11-3.0	3000	
	S6-L-B11-5.0	5000	
	S6-L-B11-10.0	10000	

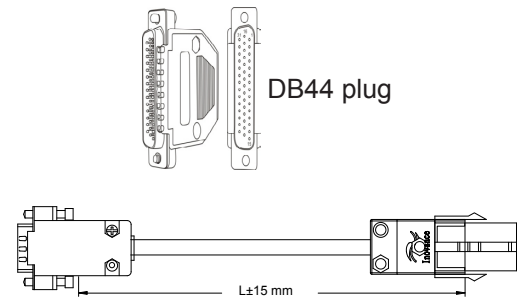
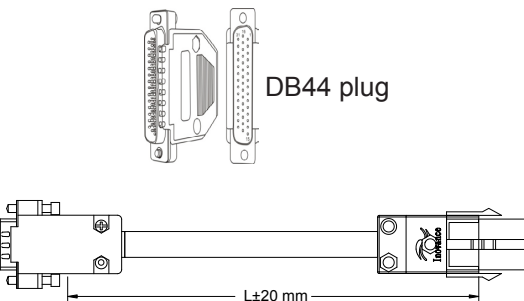
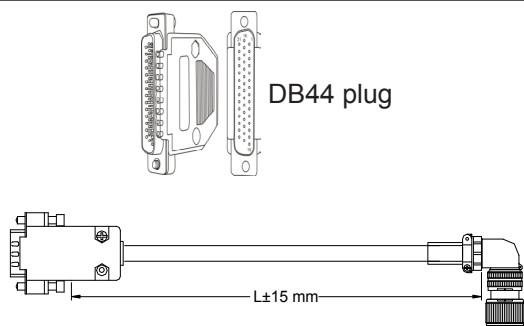
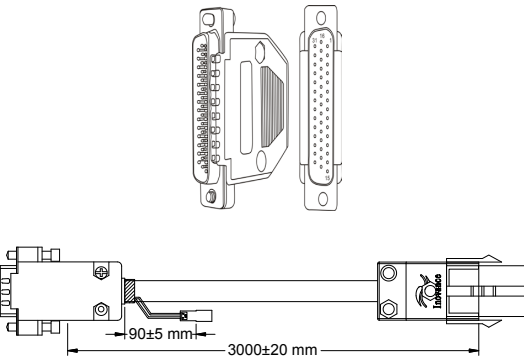
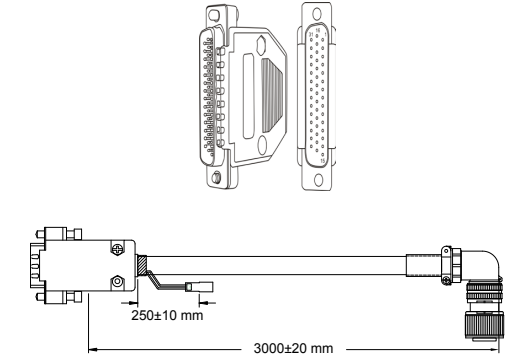
Cable Name	Cable Model	Cable Length (mm)	Cable Appearance
Servo incremental encoder cable	S6-L-P00-3.0	3000	 <p>DB44 plug</p> <p>$L \pm 15$ mm</p>
	S6-L-P00-5.0	5000	
	S6-L-P00-10.0	10000	
	S60-L-P00-3.0	3000	 <p>DB44 plug</p> <p>$L \pm 20$ mm</p>
	S60-L-P00-5.0	5000	
	S60-L-P00-10.0	10000	
Servo absolute encoder cable	S6-L-P01-3.0	3000	 <p>DB44 plug</p> <p>$L \pm 15$ mm</p>
	S6-L-P01-5.0	5000	
	S6-L-P01-10.0	10000	
Servo absolute encoder cable	S6-L-P20-3.0	3000	 <p>90 ± 5 mm</p> <p>3000 ± 20 mm</p>
	S6-L-P20-5.0	5000	
	S6-L-P20-10.0	10000	
	S6-L-P21-3.0	3000	 <p>250 ± 10 mm</p> <p>3000 ± 20 mm</p>
	S6-L-P21-5.0	5000	
	S6-L-P21-10.0	10000	

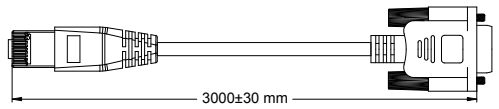
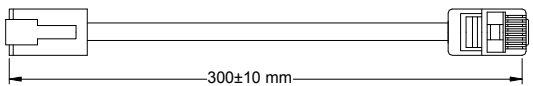
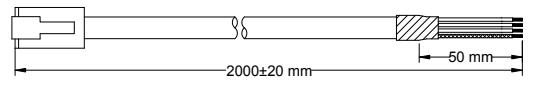
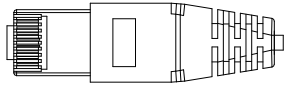
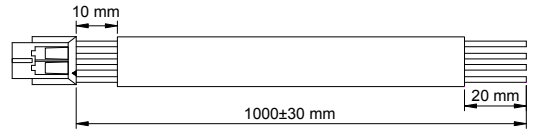
Cable Name	Cable Model	Cable Length (mm)	Cable Appearance
Servo drive to PC communication cable	S6-L-T00-3.0	3000	
Communication cable for multi-drive parallel connection	S6-L-T01-0.3	300	
Servo drive to PLC communication cable	S6-L-T02-2.0	2000	
Servo drive communication terminal resistor	S6-L-T03-0.0	0	
Servo drive AO cable with loose wire at one end	S5-L-A01-1.0	1000	

10.2 Mounting Dimensions of Servo Motor

10.2.1 Mounting Dimensions of ISMH1 Series Z Motor

1) 100 W ($V_n = 3000 \text{ RPM}$, $V_{max} = 5000 \text{ RPM}$)

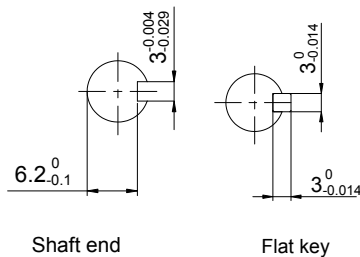
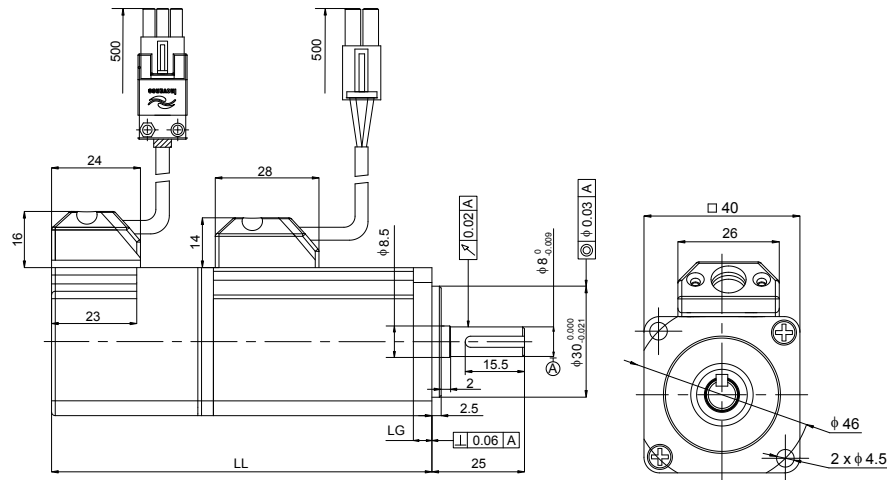

Connector	Power Side (with Brake)	Encoder Side
Plastic housing	MOLEX-50361672	AMP 172169-9
Terminal	MOLEX-39000059	AMP 1473226-1

Model	LL (mm)	LG (mm)	TP (mm)	Weight (kg)
ISMH1-10B30CB-U***Z	106.5 (139.6)	5	M3 x 6	0.59 (0.77)
ISMH1-10B30CB-A***Z	106.5 (139.6)	5	M3 x 6	0.59 (0.77)

2) 200 W, 400W (Vn = 3000 RPM, Vmax = 6000 RPM)

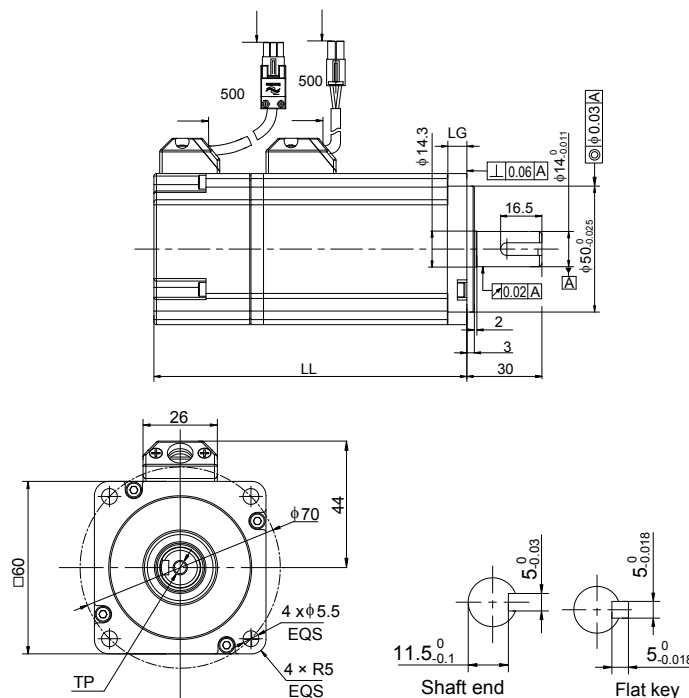

Connector	Power Side (with Brake)	Encoder Side
Plastic housing	MOLEX-50361672	AMP 172169-9
Terminal	MOLEX-39000059	AMP 1473226-1

Model	LL (mm)	LG (mm)	TP (mm)	Weight (kg)
ISMH1-20B30CB-U2**Z	98 (138)	7.6	M5 x 8	1.1 (1.4)
ISMH1-20B30CB-A3**Z				
ISMH1-40B30CB-U2*1Z	118			1.6
ISMH1-40B30CB-A3*1Z				

3) 750 W (Vn = 3000 RPM, Vmax = 6000 RPM)

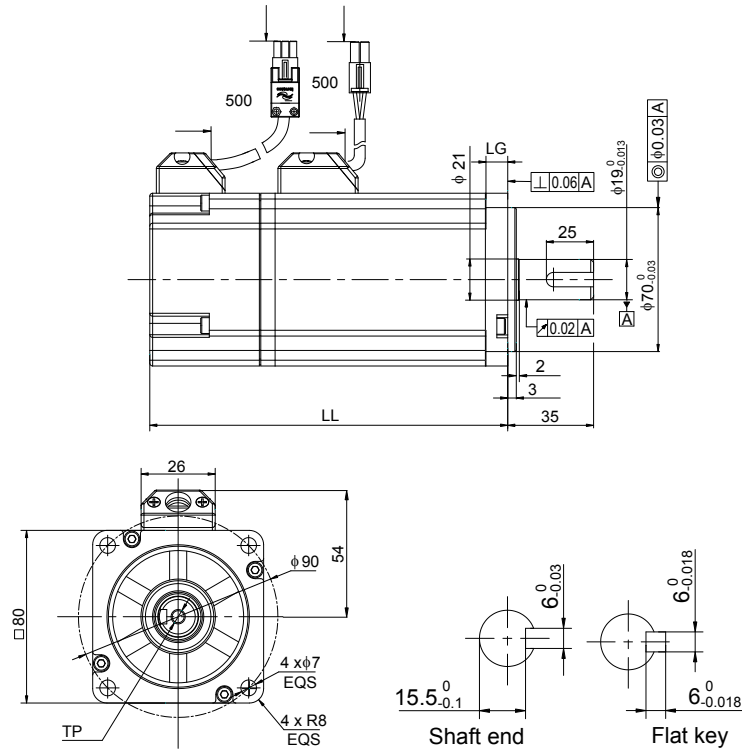

Connector	Power Side	Encoder Side
Plastic housing	MOLEX-50361672	AMP 172169-9
Terminal	MOLEX-39000059	AMP 1473226-1

Model	LL (mm)	LG (mm)	TP (mm)	Weight (kg)
ISMH1-75B30CB-U**1Z	135.5	7.8	M6 x 20	2.7
ISMH1-10C30CB-A**1Z				

10.2.2 Mounting Dimensions of ISMH1 Series X Motor

1) 100 W ($V_n = 3000 \text{ RPM}$, $V_{max} = 5000 \text{ RPM}$)

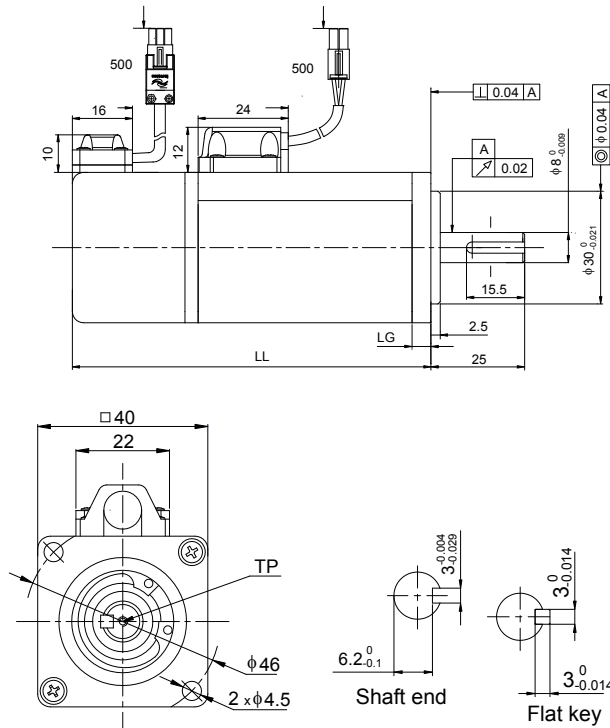

Connector	Power Side	Brake	Encoder Side
Plastic housing	CWB EL-4Y	AMP 172165-1	AMP 172169-1
Terminal	CMB 422.6006.0	AMP 770834-1	AMP 770834-1

Model	LL (mm)	LG (mm)	TP (mm)	Weight (kg)
ISMH1-10B30CB-U***X	106.5 (139.6)	5	M3 x 6	0.59 (0.77)

Note	This series X motors are no longer manufactured.
-------------	--

2) 200 W, 400W (Vn = 3000 RPM, Vmax = 6000 RPM)

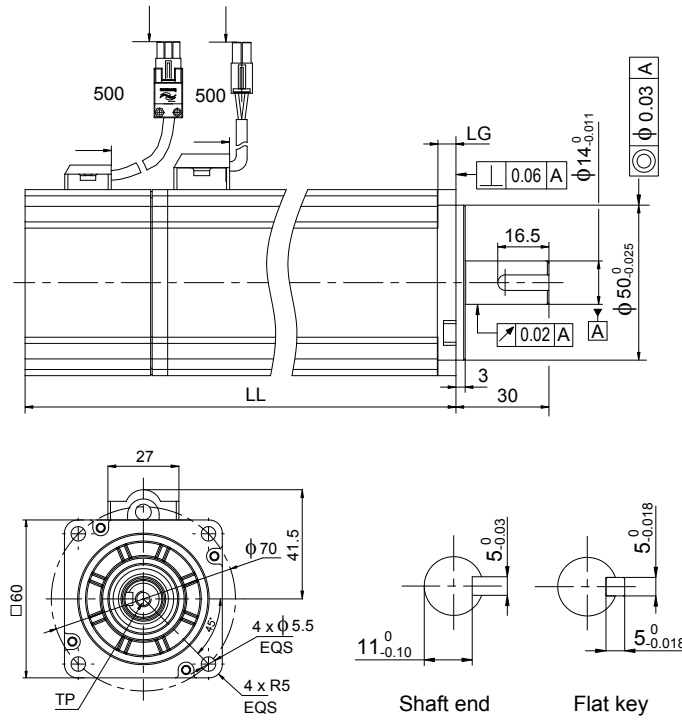

Connector	Power Side	Brake	Encoder Side
Plastic housing	CWB EL-4Y	AMP 172165-1	AMP 172169-1
Terminal	CMB 422.6006.0	AMP 770834-1	AMP 770834-1

Model	LL (mm)	LG (mm)	TP (mm)	Weight (kg)
ISMH1-20B30CB-U***X	114 (153)	5.8	M5 x 8	1.1 (1.4)
ISMH1-40B30CB-U***X	139 (178)			1.6 (1.9)

Note	This series X motors are no longer manufactured.
-------------	--

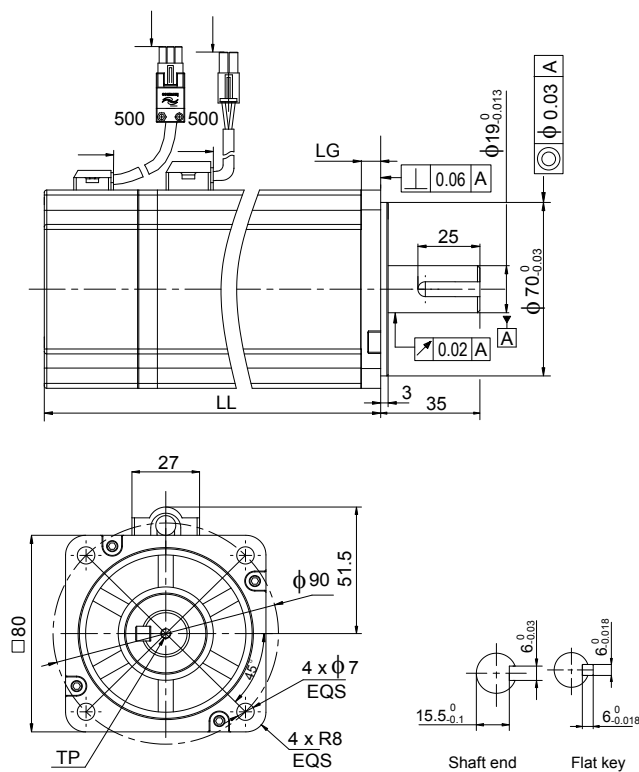
3) 750 W ($V_n = 3000$ RPM, $V_{max} = 6000$ RPM)

Connector	Power Side	Brake	Encoder Side
Plastic housing	CWB EL-4Y	AMP 172165-1	AMP 172169-1
Terminal	CMB 422.6006.0	AMP 770834-1	AMP 770834-1

Model	LL (mm)	LG (mm)	TP (mm)	Weight (kg)
ISMH1-75B30CB-U***X	135.5 (182.5)	7.8	M6 x 10	2.7 (3.1)

Note

This series X motors are no longer manufactured.

10.2.3 Mounting Dimensions of ISMH2 (Vn = 3000 RPM, Vmax = 6000/5000 RPM)

1) 1.0 kW, 1.5 kW, 2.0 kW, 2.5 kW

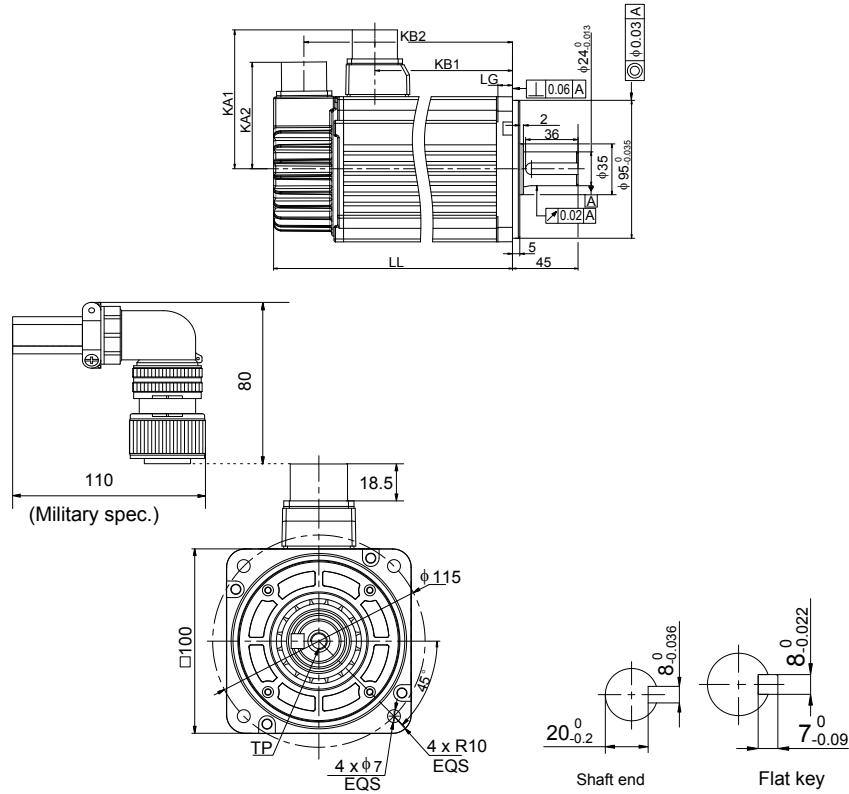

Connector	Power Side	Encoder Side
Military spec.	MIL-DTL-5015 series 3102E20-18P	MIL-DTL-5015 series 3102E20-29P

Model	LL (mm)	LG (mm)	TP (mm)	KA1 (mm)	KA2 (mm)	KB1 (mm)	KB2 (mm)	Weight (kg)
ISMH2-10C30CB(D)-U***Y	164	10	M8 x 16	96	74	94.5	143.5	5.11
ISMH2-10C30CB(D)-A***Y	(213)					(101)	(192.5)	(6.41)
ISMH2-15C30CB(D)-U***Y	189					119.5	168.5	6.22
ISMH2-15C30CB(D)-A***Y	(239)					(128)	(219.5)	(7.52)
ISMH2-20C30CD-U***Y	214					144.5	193.5	7.39
ISMH2-20C30CD-A***Y								
ISMH2-25C30CD-U***Y	239					169.5	218.5	8.55
ISMH2-25C30CD-A***Y								

2) 3.0 kW, 4.0 kW, 5.0 kW

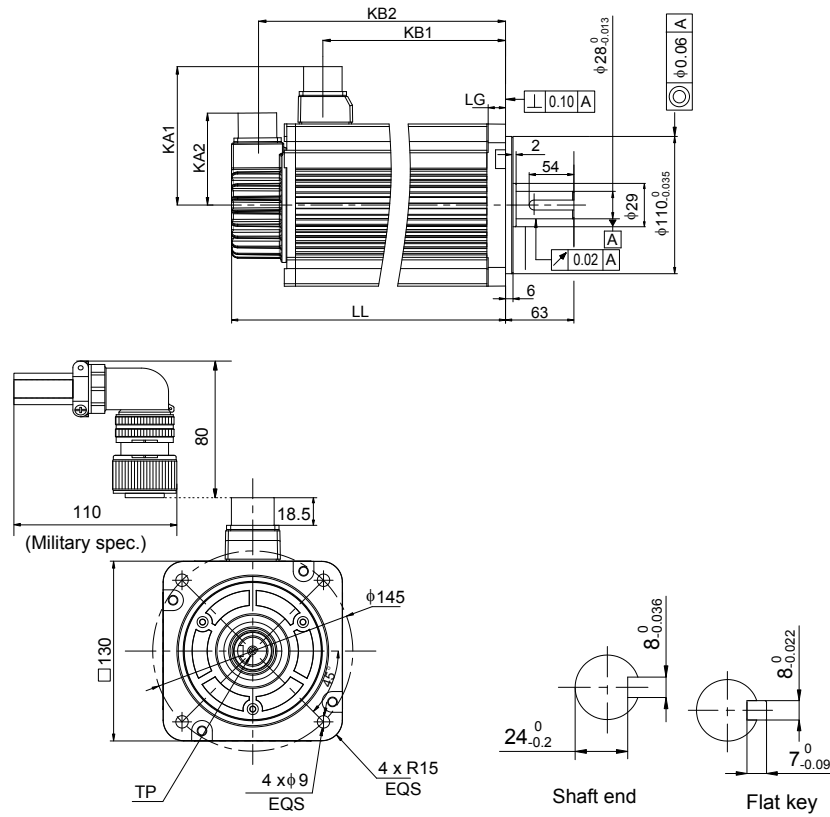

Connector	Power Side	Encoder Side
Military spec.	MIL-DTL-5015 series 3102E20-18P	MIL-DTL-5015 series 3102E20-29P

Model	LL (mm)	LG (mm)	TP (mm)	KA1 (mm)	KA2 (mm)	KB1 (mm)	KB2 (mm)	Weight (kg)
ISMH2-30C30CD-U***Y	209.5	14	M8 x 20	111	74	136	188.5	10.73
ISMH2-30C30CD-A***Y						178.5	231	15.43
ISMH2-40C30CD-U***Y	252					221	273.5	16.2
ISMH2-40C30CD-A***Y						221	273.5	16.2
ISMH2-50C30CD-U***Y	294.5					221	273.5	16.2
ISMH2-50C30CD-A***Y						221	273.5	16.2

10.2.4 Mounting Dimensions of ISMH3 (Vn = 1500 RPM, Vmax = 3000 RPM)

1) 850 W, 1.3 kW, 1.8k W

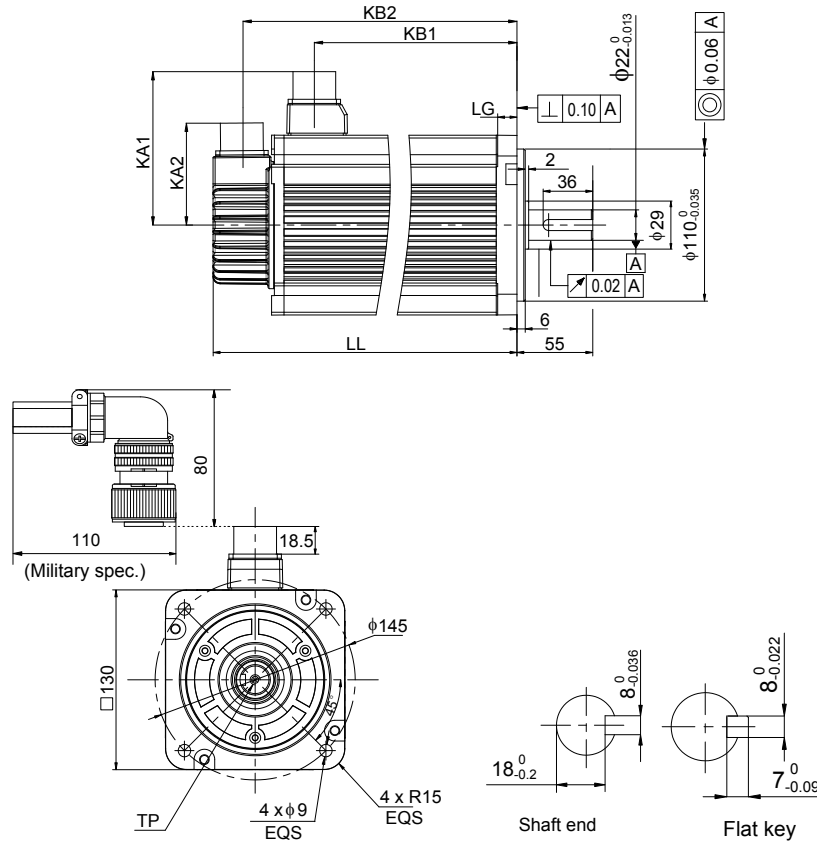

Connector	Power Side	Encoder Side
Military spec.	MIL-DTL-5015 series 3102E20-18P	MIL-DTL-5015 series 3102E20-29P

Model	LL (mm)	LG (mm)	TP (mm)	KA1 (mm)	KA2 (mm)	KB1 (mm)	KB2 (mm)	Weight (kg)
ISMH3-85B15CB(D)-U***Y	168.5	14	M6x20	111	74	95	147.5	8.23
ISMH3-85B15CB(D)-A***Y	(227.5)						(191.5)	(10.73)
ISMH3-13C15CB(D)-U***Y	194.5					121	173.5	10.57
ISMH3-13C15CB(D)-A***Y	(253.5)					(217.5)	(13.0)	
ISMH3-18C15CD-U***Y	220.5					147	199.5	12.7
ISMH3-18C15CD-A***Y	(279.5)					(243.5)	(15.2)	

2) 2.9 kW, 4.4 kW, 5.5 kW, 7.5 kW

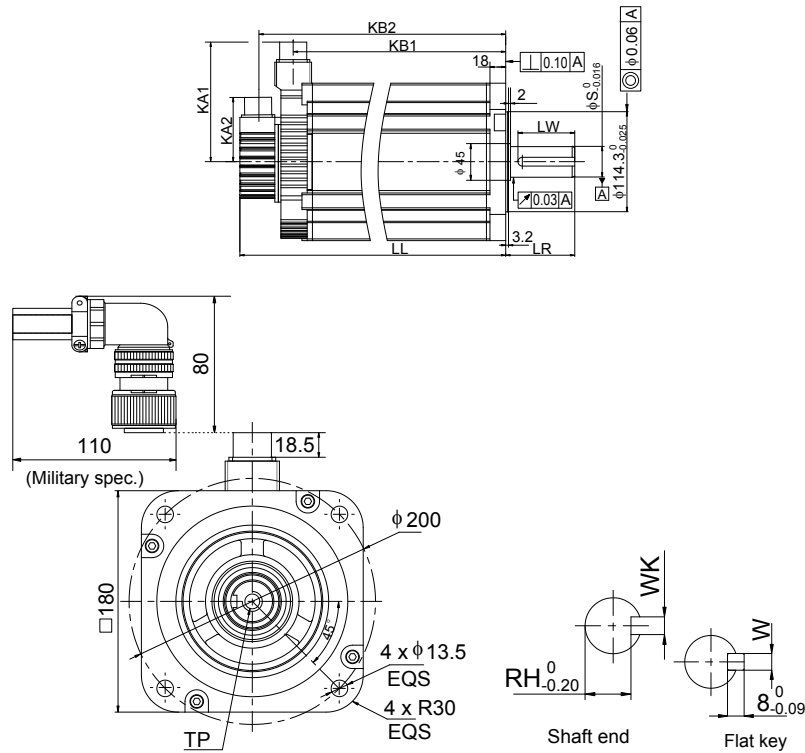

Connector	Power Side	Encoder Side
Military spec.	MIL-DTL-5015 series 3102E20-22P	MIL-DTL-5015 series 3102E20-29P

Model	LL	LR	LW	S	RH	WK	W	TP	KA1	KA2	KB1	KB2	Weight (kg)
	(mm)												
ISMH3-29C15CD-U***Z	197 (273)	79	65	35	30	10 ⁰ _{-0.036}	10 ⁰ _{-0.022}	M12*25	138	74	136	177	15 (25)
ISMH3-29C15CD-A***Z											(134)	(253)	
ISMH3-44C15CD-U***Z	230 (307)	79	65	35	30	10 ⁰ _{-0.036}	10 ⁰ _{-0.022}	M12*25	138	74	169	210	19.5 (30)
ISMH3-44C15CD-A***Z											(167)	(286)	

Model	LL	LR	LW	S	RH	WK	W	TP	KA1	KA2	KB1	KB2	Weight (kg)
	(mm)												
ISMH3-55C15CD-U***Z	274 (350)										213 (211)	254 (330)	28 (38)
ISMH3-55C15CD-A***Z													
ISMH3-75C15CD-U***Z	330 (407)	113	96	42	37	12 ⁰ _{-0.043}	12 ⁰ _{-0.027}	M16*32	138	74	269 (267)	310 (386)	32 (42)
ISMH3-75C15CD-A***Z													

Note The U1 series Y motors are no longer manufactured.

10.2.5 Mounting Dimensions of ISMH4 (Vn = 3000 RPM, Vmax = 6000 RPM) Series Z Motor

1) 400 W

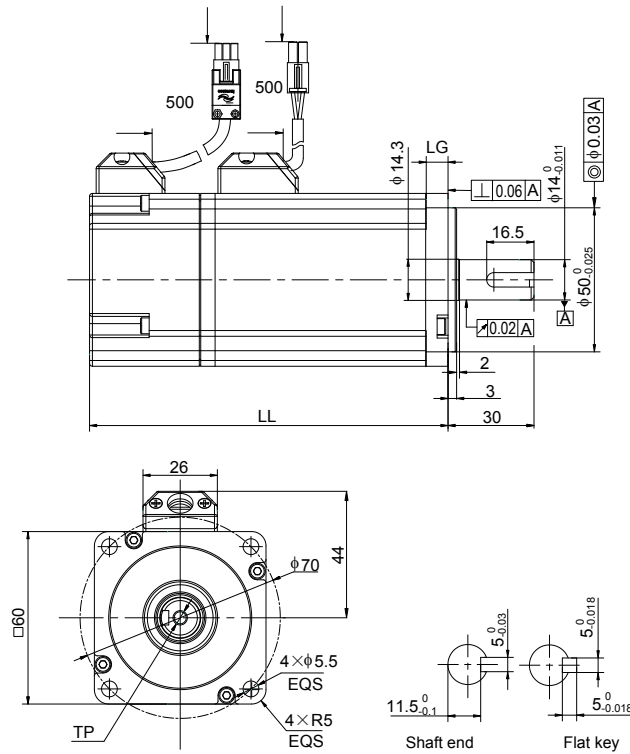

Connector	Power Side (with Brake)	Encoder Side
Plastic housing	MOLEX-50361672	AMP 172169-9
Terminal	MOLEX-39000059	AMP 1473226-1

Model	LL (mm)	LG (mm)	TP (mm)	Weight (kg)
ISMH4-40B30CB-U2**Z	125 (165)	7.6	M5 x 8	1.7 (2.0)
ISMH4-40B30CB-A2**Z				

2) 750 W

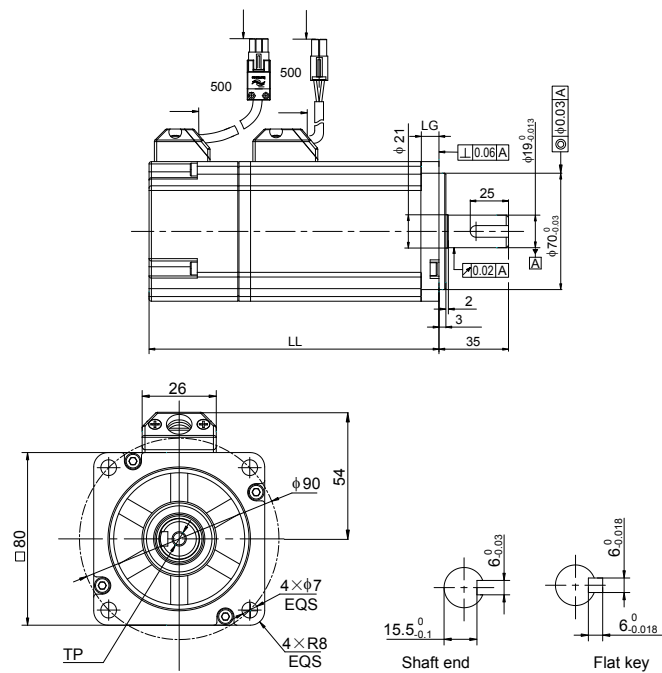

Connector	Power Side (with Brake)	Encoder Side
Plastic housing	MOLEX-50361672	AMP 172169-9
Terminal	MOLEX-39000059	AMP 1473226-1

Model	LL (mm)	LG (mm)	TP (mm)	Weight (kg)
ISMH4-75B30CB-U***Z	146.5	7.8	M6 x 20	2.9 (3.3)
ISMH4-75B30CB-A***Z	(184.5)			

10.2.6 Mounting Dimensions of ISMH4 (Vn = 3000 RPM, Vmax = 6000 RPM) Series X Motor

1) 400 W

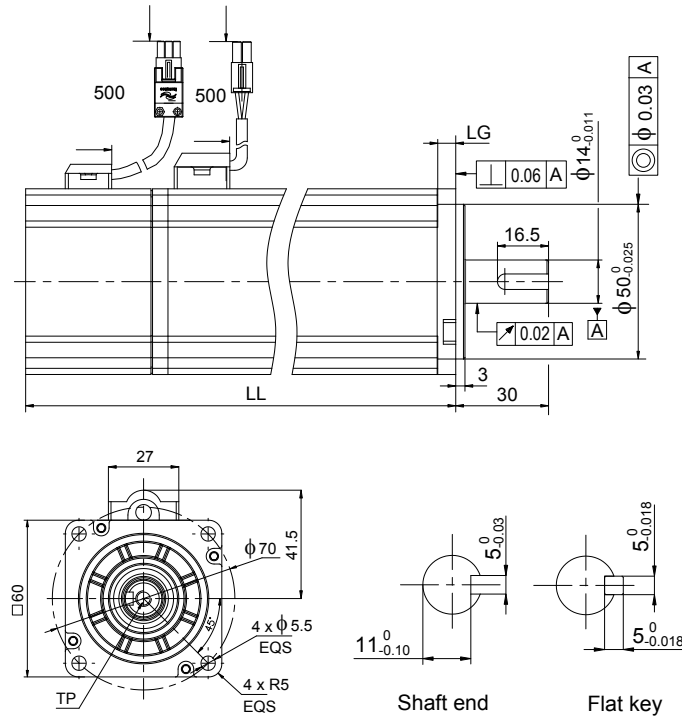

Connector	Power Side	Brake	Encoder Side
Plastic housing	CWB EL-4Y	AMP 172165-1	AMP 172169-1
Terminal	CMB 422.6006.0	AMP 770834-1	AMP 770834-1

Model	LL (mm)	LG (mm)	T (mm)	TP (mm)	Weight (kg)
ISMH4-40B30CB-U***X	147.5	5.8	5	M5 x 8	1.7

Note	This series X motors are no longer manufactured.
-------------	--

2) 750 W

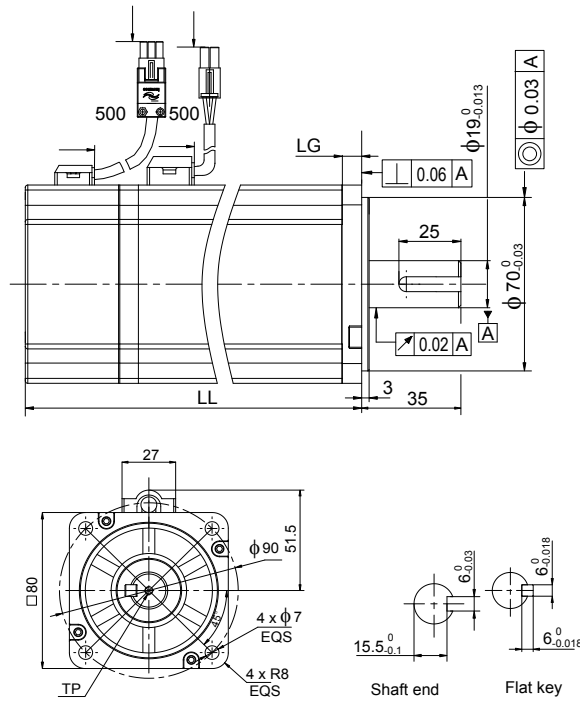

Connector	Power Side	Brake	Encoder Side
Plastic housing	CWB EL-4Y	AMP 172165-1	AMP 172169-1
Terminal	CMB 422.6006.0	AMP 770834-1	AMP 770834-1

Model	LL (mm)	LG (mm)	TP (mm)	Weight (kg)
ISMH4-75B30CB-U2**X	146.5 (193.5)	7.8	M6 x 10	2.9 (3.3)

Note	This series X motors are no longer manufactured.
-------------	--

10.3 Physical Appearance and Mounting Dimensions of Servo Drive

SIZE A: IS620PS1R6I, IS620PS2R8I, IS620PS5R5I

SIZE C: IS620PS7R6I, IS620PS012I, IS620PT3R5I, IS620PT5R4I, IS620PT8R4I, IS620PT012I

SIZE E: IS620PT017I, IS620PT021I, IS620PT026I

Figure 10-1 Physical appearance and mounting dimensions of servo drive

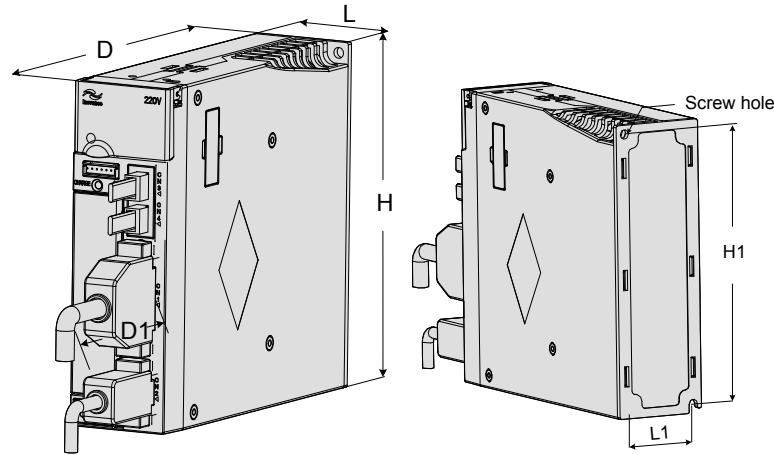

Size	L (mm)	H (mm)	D (mm)	L1 (mm)	H1 (mm)	D1 (mm)	Screw Hole	Tightening Torque (Nm)
SIZE A	50	160	173	40	150	75	2-M4	0.6 to 1.2
SIZE C	90	160	183	80	150	75	4-M4	0.6 to 1.2
SIZE E	100	250	230	90	240	75	4-M4	0.6 to 1.2

10.4 Parameter Table

Group H00: Servo motor parameters

Function Code	Parameter Name	Setting Range	Unit	Default	Effective Time	Property	Control Mode	Page
H00-00	Motor SN	14000: Inovance 20-bit incremental encoder motor 14101: Inovance 23-bit absolute encoder motor	-	14000	Power-on again	At stop	ALL	303
H00-02	Customized firmware version	-	-	-	-	At display	-	303
H00-04	Encoder version	-	-	-	-	At display	-	303
H00-05	Serial encoder motor SN	-	-	-	-	At display	-	303
H00-09	Rated voltage	0: 220 1: 380	V	-	Power-on again	At stop	-	303

Function Code	Parameter Name	Setting Range	Unit	Default	Effective Time	Property	Control Mode	Page
H00-10	Rated power	0.01 to 655.35	kW	-	Power-on again	At stop	-	303
H00-11	Rated current	0.01 to 655.35	A	-	Power-on again	At stop	-	304
H00-12	Rated torque	0.01 to 655.35	Nm	-	Power-on again	At stop	-	304
H00-13	Max. torque	0.10 to 655.35	Nm	-	Power-on again	At stop	-	304
H00-14	Rated motor speed	100 to 6000	RPM	-	Power-on again	At stop	-	304
H00-15	Max. motor speed	100 to 6000	RPM	-	Power-on again	At stop	-	304
H00-16	Rotor inertia Jm	0.01 to 655.35	kgcm ²	-	Power-on again	At stop	-	304
H00-17	Number of pole pairs of PMSM	2 to 360	Pole-pair	-	Power-on again	At stop	-	304
H00-18	Stator resistance	0.001 to 65.535	Ω	-	Power-on again	At stop	-	304
H00-19	Stator inductance Lq	0.01 to 655.35	mH	-	Power-on again	At stop	-	304
H00-20	Stator inductance Ld	0.01 to 655.35	mH	-	Power-on again	At stop	-	304
H00-21	Linear back EMF coefficient	0.01 to 655.35	mV/RPM	-	Power-on again	At stop	-	305
H00-22	Torque coefficient Kt	0.01 to 655.35	Nm/Arms	-	Power-on again	At stop	-	305
H00-23	Electrical constant Te	0.01 to 655.35	ms	-	Power-on again	At stop	-	305
H00-24	Mechanical constant Tm	0.01 to 655.35	ms	-	Power-on again	At stop	-	305
H00-28	Position offset of absolute encoder	0 to 1073741824	P/r	-	Power-on again	At stop	-	305
H00-30	Encoder selection (Hex)	0x000: Common incremental encoder (UVW-ABZ) 0x013: Inovance 20-bit serial encoder	1	0x013	Power-on again	At stop	-	305
H00-31	PPR of encoder	0 to 1073741824	P/r	1048576	Power-on again	At stop	-	305
H00-33	Electrical angle of signal Z	0.0 to 360	°	180	Power-on again	At stop	-	305
H00-34	Electrical angle of phase U rise edge	0.0 to 360	°	180	Power-on again	At stop	-	305

Group H01: Servo Drive Parameters

Function Code	Parameter Name	Setting Range	Unit	Default	Effective Time	Property	Control Mode	Page
H01-00	MCU firmware version	0 to 65535	-	-	-	At display	-	306
H01-01	FPGA firmware version	0 to 65535	-	-	-	At display	-	306
H01-02	Servo drive SN	0 to 65535	-	-	Power-on again	At stop	-	306

Group H02: Basic Control Parameters

Function Code	Parameter Name	Setting Range	Unit	Default	Effective Time	Property	Control Mode	Page
H02-00	Control mode selection	0: Speed mode 1: Position mode 2: Torque mode 3: Torque mode/Speed mode 4: Speed mode/Position mode 5: Torque mode/Position mode 6: Torque mode/Speed mode/Position mode	-	1	Immediate	At stop	-	307
H02-01	Absolute system selection	0: Incremental position mode 1: Absolute position linear mode 2: Absolute position rotating mode	-	0	Power-on again	At stop	ALL	307
H02-02	Rotating direction selection	0: CCW direction as forward direction (phase A advancing phase B) 1: CW direction as forward direction (phase A lagging phase B)	-	0	Power-on again	At stop	PST	308
H02-03	Output pulse phase	0: CCW direction as forward direction (phase A advancing phase B) 1: CW direction as forward direction (phase A lagging phase B)	-	0	Power-on again	At stop	PST	308
H02-05	Stop mode at S-ON off	0: Coast to stop, keeping de-energized state 1: Emergency stop, keeping de-energized state	-	0	Immediate	At stop	PST	308
H02-06	Stop mode at NO.2 fault	0: Coast to stop, keeping de-energized state 1: Emergency stop, keeping de-energized state	-	0	Immediate	At stop	PST	309

Function Code	Parameter Name	Setting Range	Unit	Default	Effective Time	Property	Control Mode	Page
H02-07	Stop mode at limit switch signal	0: Coast to stop, keeping de-energized state 1: Emergency stop, keeping position locking state 2: Emergency stop, keeping de-energized state	-	1	Immediate	At stop	PST	309
H02-08	Stop mode at NO.1 fault	0: Coast to stop, keeping de-energized state	-	0	Immediate	At stop	PST	309
H02-09	Delay from brake output ON to command received	0 to 500	ms	250	Immediate	During running	PS	310
H02-10	Delay from brake output OFF to motor de-energized in static state	1 to 1000	ms	150	Immediate	During running	PS	310
H02-11	Motor speed threshold at brake output OFF in rotating state	0 to 3000	RPM	30	Immediate	During running	PS	310
H02-12	Delay from brake output OFF to motor de-energized in rotating state	1 to 1000	ms	500	Immediate	During running	PS	310
H02-15	Warning display on keypad	0: Output warning information immediately 1: Not output warning information	-	0	Immediate	At stop	PST	310
H02-18	Filter time of S-ON signal	0 to 64	ms	0	Immediate	At stop	PST	311
H02-21	Permissible minimum resistance of regenerative resistor	-	Ω	-	-	At display	PST	311
H02-22	Power of built-in regenerative resistor	-	W	-	-	At display	PST	311
H02-23	Resistance of built-in regenerative resistor	-	Ω	-	-	At display	PST	311
H02-24	Resistor heat dissipation coefficient	10 to 100	%	30	Immediate	At stop	PST	311

Function Code	Parameter Name	Setting Range	Unit	Default	Effective Time	Property	Control Mode	Page
H02-25	Regenerative resistor type	0: Built-in 1: External, naturally ventilated 2: External, forcible cooling 3: No resistor, using only capacitor	-	0	Immediate	At stop	PST	312
H02-26	Power of external regenerative resistor	1 to 65535	W	-	Immediate	At stop	PST	312
H02-27	Resistance of external regenerative resistor	1 to 1000	Ω	-	Immediate	At stop	PST	312
H02-30	User password	0 to 65535	-	0	Power-on again	At stop	PST	313
H02-31	Parameter initialization	0: No operation 1: Restore default setting (except the parameters in groups H00 and H01.) 2: Clear fault records	-	0	Immediate	At stop	PST	313
H02-32	Default keypad display	0 to 99	-	50	Immediate	During running	-	313
H02-33	EtherCAT software version	-	-	-	-	At display	-	313
H02-34	CAN firmware version	-	-	-	-	At display	-	313

Group H03: Input Terminal Parameters

Function Code	Parameter Name	Setting Range	Unit	Default	Effective Time	Property	Control Mode	Page
H03-00	DI function (active after power-on) allocation 1	0–0xFFFF Bit0: FunIN.1 Bit1: FunIN.2 Bit15: FunIN.16	-	0	Power-on again	During running	-	314
H03-01	DI function (active after power-on) allocation 2	0–0xFFFF Bit0: FunIN.17 Bit1: FunIN.18 Bit15: FunIN.32	-	0	Power-on again	During running	-	315
H03-02	DI1 function selection	0 to 37	-	14	At stop	During running	-	315

Function Code	Parameter Name	Setting Range	Unit	Default	Effective Time	Property	Control Mode	Page
H03-03	DI1 logic selection	Input polarity: 0 to 4 0: Low level valid 1: High level valid 2: Rising edge valid 3: Falling edge valid 4: Rising edge and falling edge both valid	-	0	At stop	During running	-	317
H03-04	DI2 function selection	0 to 37	-	15	At stop	During running	-	317
H03-05	DI2 logic selection	Input polarity: 0 to 4 0: Low level valid 1: High level valid 2: Rising edge valid 3: Falling edge valid 4: Rising edge and falling edge both valid	-	0	At stop	During running	-	317
H03-06	DI3 function selection	0 to 37	-	13	At stop	During running	-	317
H03-07	DI3 logic selection	Input polarity: 0 to 4 0: Low level valid 1: High level valid 2: Rising edge valid 3: Falling edge valid 4: Rising edge and falling edge both valid	-	0	At stop	During running	-	317
H03-08	DI4 function selection	0 to 37	-	2	At stop	During running	-	318
H03-09	DI4 logic selection	Input polarity: 0 to 4 0: Low level valid 1: High level valid 2: Rising edge valid 3: Falling edge valid 4: Rising edge and falling edge both valid	-	0	At stop	During running	-	318
H03-10	DI5 function selection	0 to 37	-	1	At stop	During running	-	318
H03-11	DI5 logic selection	Input polarity: 0 to 4 0: Low level valid 1: High level valid 2: Rising edge valid 3: Falling edge valid 4: Rising edge and falling edge both valid	-	0	At stop	During running	-	318
H03-12	DI6 function selection	0 to 37	-	12	At stop	During running	-	318
H03-13	DI6 logic selection	Input polarity: 0 to 4 0: Low level valid 1: High level valid 2: Rising edge valid 3: Falling edge valid 4: Rising edge and falling edge both valid	-	0	At stop	During running	-	318

Function Code	Parameter Name	Setting Range	Unit	Default	Effective Time	Property	Control Mode	Page
H03-14	DI7 function selection	0 to 37	-	3	At stop	During running	-	318
H03-15	DI7 logic selection	Input polarity: 0 to 4 0: Low level valid 1: High level valid 2: Rising edge valid 3: Falling edge valid 4: Rising edge and falling edge both valid	-	0	At stop	During running	-	318
H03-16	DI8 function selection	0 to 37	-	31	At stop	During running	-	319
H03-17	DI8 logic selection	Input polarity: 0 to 4 0: Low level valid 1: High level valid 2: Rising edge valid 3: Falling edge valid 4: Rising edge and falling edge both valid	-	0	At stop	During running	-	319
H03-18	DI9 function selection	0 to 37	-	0	At stop	During running	-	319
H03-19	DI9 logic selection	Input polarity: 0 to 4 0: Low level valid 1: High level valid 2: Rising edge valid 3: Falling edge valid 4: Rising edge and falling edge both valid	-	0	At stop	During running	-	319
H03-34	DI function (active after power-on) allocation 3	0 to 0xFFFF Bit0: FunIN.33 Bit1: FunIN.34 Bit15: FunIN.48	-	0	Power-on again	During running	-	320
H03-35	DI function (active after power-on) allocation 4	0 to 0xFFFF Bit0: FunIN.49 Bit1: FunIN.50 Bit15: FunIN.64	-	0	Power-on again	During running	-	320
H03-50	AI1 offset	-5000 to 5000	mV	0	Immediate	During running	-	321
H03-51	AI1 filter time constant	0 to 655.35	ms	2.00	Immediate	During running	-	321
H03-53	AI1 dead zone	0 to 1000.0	mV	10.0	Immediate	During running	-	322
H03-54	AI1 zero drift	-500.0 to 500.0	mV	0.0	Immediate	During running	-	322
H03-55	AI2 offset	-5000 to 5000	mV	0	Immediate	During running	-	322

Function Code	Parameter Name	Setting Range	Unit	Default	Effective Time	Property	Control Mode	Page
H03-56	AI2 filter time constant	0 to 655.35	ms	2.00	Immediate	During running	-	322
H03-58	AI2 dead zone	0 to 1000.0	mV	10.0	Immediate	During running	-	322
H03-59	AI2 zero drift	-500.0 to 500.0	mV	0.0	Immediate	During running	-	323
H03-80	Speed corresponding to 10 V	0RPM to 9000RPM	1RPM	3000 RPM	Immediate	At stop	-	323
H03-81	Torque corresponding to 10 V	1.00 to 8.00 times of rated torque	1.00 time of rated torque	1.00 time of rated torque	Immediate	At stop	-	323

Group H04: Output Terminal Parameters

Function Code	Parameter Name	Setting Range	Unit	Default	Effective Time	Property	Control Mode	Page
H04-00	DO1 function selection	0 to 19	-	1	At stop	During running	-	324
H04-01	DO1 logic selection	0: Output low level when valid (optocoupler ON) 1: Output high level when valid (optocoupler OFF)	-	0	At stop	During running	-	324
H04-02	DO2 function selection	0 to 19	-	5	At stop	During running	-	325
H04-03	DO2 logic selection	0: Output low level when valid (optocoupler ON) 1: Output high level when valid (optocoupler OFF)	-	0	At stop	During running	-	325
H04-04	DO3 function selection	0 to 19	-	3	At stop	During running	-	325
H04-05	DO3 logic selection	0: Output low level when valid (optocoupler ON) 1: Output high level when valid (optocoupler OFF)	-	0	At stop	During running	-	325
H04-06	DO4 function selection	0 to 19	-	11	At stop	During running	-	325
H04-07	DO4 logic selection	0: Output low level when valid (optocoupler ON) 1: Output high level when valid (optocoupler OFF)	-	0	At stop	During running	-	325
H04-08	DO5 function selection	0 to 19	-	16	At stop	During running	-	325

Function Code	Parameter Name	Setting Range	Unit	Default	Effective Time	Property	Control Mode	Page
H04-09	DO5 logic selection	0: Output low level when valid (optocoupler ON) 1: Output high level when valid (optocoupler OFF)	-	0	At stop	During running	-	326
H04-22	DO source	0 to 31	-	0	Immediate	At stop	-	326
H04-50	AO1 signal selection	00: Motor speed (1 V/1000 RPM) 01: Speed reference (1 V/1000 RPM) 02: Torque reference (1 V/1 time of rated motor torque) 03: Position deviation (0.05 V/1 reference unit) 04: Position deviation (0.05 V/1 encoder unit) 05: Position reference speed (1 V/1000 RPM) 06: Positioning completed (positioning completed: 5 V, positioning not completed: 0 V) 07: Speed feedforward (1 V/1000 RPM) 08: AI1 voltage 09: AI2 voltage	-	0	Immediate	During running	-	327
H04-51	AO1 offset voltage	-10000 to 10000	mV	5000	Immediate	During running	-	328
H04-52	AO1 multiplying factor	-99.99 to 99.99	times	1.00	Immediate	During running	-	328
H04-53	AO2 signal selection	00: Motor speed (1 V/1000 RPM) 01: Speed reference (1 V/1000 RPM) 02: Torque reference (1 V/1 time of rated motor torque) 03: Position deviation (0.05 V/1 reference unit) 04: Position deviation (0.05 V/1 encoder unit) 05: Position reference speed (1 V/1000 RPM) 06: Positioning completed (positioning completed: 5 V, positioning not completed: 0 V) 07: Speed feedforward (1 V/1000 RPM) 08: AI1 voltage 09: AI2 voltage	-	0	Immediate	During running	-	328

Function Code	Parameter Name	Setting Range	Unit	Default	Effective Time	Property	Control Mode	Page
H04-54	AO2 offset voltage	-10000 to 10000	mV	5000	Immediate	During running	-	328
H04-55	AO2 multiplying factor	-99.99 to 99.99	times	1.00	Immediate	During running	-	328

Group H05: Position Control Parameters

Function Code	Parameter Name	Setting Range	Unit	Default	Effective Time	Property	Control Mode	Page
H05-00	Position reference source	0: Pulse input 1: Step setting 2: Multi-position reference	-	0	Immediate	At stop	P	329
H05-01	Pulse input terminal selection	0: Low-speed terminals 1: High-speed terminals	-	0	Immediate	At stop	P	329
H05-02	Pulses per one motor revolution	0 to 1048576	P/r	0	Power-on again	At stop	P	331
H05-04	Time constant of first-order low-pass filter	0 to 6553.5	ms	0.0	Immediate	At stop	P	331
H05-05	Step amount	-9999 to 9999	Reference unit	50	Immediate	At stop	P	331
H05-06	Time constant of moving average filter	0.0 to 128.0	ms	0.0	Immediate	At stop	P	332
H05-07	Electronic gear ratio 1 (numerator)	1 to 1073741824	-	1048576	Immediate	During running	P	332
H05-09	Electronic gear ratio 1 (denominator)	1 to 1073741824	-	10000	Immediate	During running	P	332
H05-11	Electronic gear ratio 2 (numerator)	1 to 1073741824	-	1048576	Immediate	During running	P	332
H05-13	Electronic gear ratio 2 (denominator)	1 to 1073741824	-	10000	Immediate	During running	P	332
H05-15	Pulse input format	0: Pulse + direction, positive logic 1: Pulse + direction, negative logic 2: Phase A + phase B quadrature pulse, 4-frequency multiplication 3: CW + CCW	-	0	Power-on again	At stop	P	333

Function Code	Parameter Name	Setting Range	Unit	Default	Effective Time	Property	Control Mode	Page
H05-16	Clear action	0: Clear position deviation when S-ON is turned off or a fault occurs 1: Clear position deviation pulses when S-ON is turned off or a fault occurs 2: Clear position deviation when S-ON is turned off and the ClrPosErr signal is input from DI	-	0	Immediate	At stop	P	334
H05-17	Encoder frequency-division pulses	35 to 32767	P/r	2500	Power-on again	At stop	-	335
H05-19	Speed feedforward control selection	0: No speed feedforward 1: Internal 2: AI1 3: AI2	-	1	Immediate	At stop	P	335
H05-20	Output condition of positioning completed/near signal (COIN)	0: Absolute value of position deviation is smaller than setting of H05-21/H05-22 1: Absolute value of position deviation is smaller than setting of H05-21/H05-22 and position reference after filter is 0 2: Absolute value of position deviation is smaller than setting of H05-21/H05-22 and position reference before filter is 0	-	0	Immediate	During running	P	336
H05-21	Threshold of positioning completed	1 to 65535	Encoder unit	734	Immediate	During running	P	336
H05-22	Threshold of positioning near	1 to 65535	Encoder unit	65535	Immediate	During running	P	337
H05-23	Position change on fly	0: Disabled 1: Enabled	-	0	Power-on again	At stop	P	337
H05-24	Displacement of position change on fly	0 to 1073741824	Reference unit	10000	Immediate	During running	P	337
H05-26	Constant speed for position change on fly	0 to 6000	RPM	200	Immediate	During running	P	338

Function Code	Parameter Name	Setting Range	Unit	Default	Effective Time	Property	Control Mode	Page
H05-27	Acceleration/ Deceleration time of position change on fly	0 to 1000	ms	10	Immediate	During running	P	338
H05-29	Position change on fly unlock	0: Disabled 1: Enabled	-	1	Immediate	During running	P	338
H05-30	Homing enabling method	0: Disabled 1: Input HomingStart signal from DI to enable homing 2: Input HomingStart signal from DI to enable electrical home attaining 3: Start homing immediately upon power-on 4: Perform homing immediately 5: Start electrical home attaining 6: Take current position as the home	-	0	Immediate	During running	P	339

Function Code	Parameter Name	Setting Range	Unit	Default	Effective Time	Property	Control Mode	Page
H05-31	Homing mode	0: Forward direction, deceleration point and home being home switch signal 1: Reverse direction, deceleration point and home being home switch signal 2: Forward direction, deceleration point and home being motor Z signal 3: Reverse direction, deceleration point and home being motor Z signal 4: Forward direction, deceleration point being home switch signal and home being motor Z signal 5: Reverse direction, deceleration point being home switch signal and home being motor Z signal 6: Forward direction, deceleration point and home being forward limit switch signal 7: Reverse direction, deceleration point and home being reverse limit switch signal 8: Forward direction, deceleration point being forward limit switch signal and home being motor Z signal 9: Reverse direction, deceleration point being reverse limit switch signal and home being motor Z signal	-	0	Immediate	At stop	P	339
H05-32	Low speed of homing	0 to 3000	RPM	100	Immediate	During running	P	340
H05-33	High speed of homing	0 to 1000	RPM	10	Immediate	During running	P	340
H05-34	Acceleration/Deceleration time of homing	0 to 1000	ms	1000	Immediate	At stop	P	340

Function Code	Parameter Name	Setting Range	Unit	Default	Effective Time	Property	Control Mode	Page
H05-35	Duration limit of homing	0 to 65535	ms	10000	Immediate	At stop	P	340
H05-36	Mechanical home offset	-1073741824 to 1073741824	Reference unit	0	Immediate	At stop	P	340
H05-38	Servo pulse output source	0: Encoder frequency-division output 1: Pulse synchronous output 2: Frequency-division or synchronous output inhibited	-	0	Power-on again	At stop	P	341
H05-39	Electronic gear ratio switchover condition	0: Switchover if position reference (reference unit) = 0 and the duration reaches 2.5 ms 1: Real-time switchover	-	0	Immediate	At stop	P	341
H05-40	Mechanical home offset and action after reaching limit switch	0: H05-36 as coordinate for homing, trigger homing and find home reversely after reaching limit switch 1: H05-36 as relative offset for homing, trigger homing and find home reversely after reaching limit switch 2: H05-36 as coordinate for homing, automatically find zero position reversely after reaching limit switch 3: H05-36 as relative offset for homing, automatically find zero position reversely after reaching limit switch	-	0	Immediate	At stop	P	341
H05-41	Output polarity of Z pulse	0: Positive (high level when pulse Z is valid) 1: Negative (low level when pulse Z is valid)	-	1	Power-on again	At stop	P	342
H05-46	Position offset in absolute position linear mode (low 32 bits)	-2147483648 to 2147483647	1 encoder unit	0	Power-on again	At stop	PST	343
H05-48	Position offset in absolute position linear mode (high 32 bits)	-2147483648 to 2147483647	1 encoder unit	0	Power-on again	At stop	PST	343

Function Code	Parameter Name	Setting Range	Unit	Default	Effective Time	Property	Control Mode	Page
H05-50	Mechanical gear ratio in absolute position rotating mode (numerator)	1 to 65535	1	65535	Immediate	At stop	ALL	344
H05-51	Mechanical gear ratio in absolute position rotating mode (denominator)	1 to 65535	1	1	Immediate	At stop	ALL	344
H05-52	Pulses within one revolution of load in absolute position rotating mode (low 32 bits)	0 to 4294967295	Encoder unit	0	Immediate	At stop	ALL	344
H05-54	Pulses within one revolution of load in absolute position rotating mode (high 32 bits)	0 to 127	Encoder unit	0	Immediate	At stop	ALL	344
H05-60	Positioning completed holding time	1 to 30000	ms	1	Immediate	During running	P	344

Group H06: Speed Control Parameters

Function Code	Parameter Name	Setting Range	Unit	Default	Effective Time	Property	Control Mode	Page
H06-00	Main speed reference A source	0: Digital setting (H06-03) 1: AI1 2: AI2	-	0	Immediate	At stop	S	345
H06-01	Auxiliary speed reference B source	0: Digital setting (H06-03) 1: AI1 2: AI2 3: 0 (invalid) 4: 0 (invalid) 5: Multi-speed reference	-	1	Immediate	At stop	S	345

Function Code	Parameter Name	Setting Range	Unit	Default	Effective Time	Property	Control Mode	Page
H06-02	Speed reference source selection	0: Main speed reference A source 1: Auxiliary speed reference B source 2: A + B 3: A/B switchover 4: Communication setting	-	0	Immediate	At stop	S	346
H06-03	Keypad setting value of speed reference	-6000 to 6000	RPM	200	Immediate	During running	S	346
H06-04	Jog speed setting value	0 to 6000	RPM	100	Immediate	During running	S	346
H06-05	Acceleration ramp time constant of speed reference	0 to 65535	ms	0	Immediate	During running	S	346
H06-06	Deceleration ramp time constant of speed reference	0 to 65535	ms	0	Immediate	During running	S	347
H06-07	Maximum speed limit	0 to 6000	RPM	6000	Immediate	During running	S	347
H06-08	Positive speed limit	0 to 6000	RPM	6000	Immediate	During running	S	347
H06-09	Reverse speed limit	0 to 6000	RPM	6000	Immediate	During running	S	347
H06-11	Torque feedforward control selection	0: Disabled 1: Enabled	-	1	Immediate	During running	PS	348
H06-15	Speed threshold for zero speed clamp	0 to 6000	RPM	10	Immediate	During running	S	349
H06-16	Speed threshold of motor rotation signal	0 to 1000	RPM	20	Immediate	During running	S	349
H06-17	Threshold of speed consistent signal	0 to 100	RPM	10	Immediate	During running	S	350
H06-18	Threshold of speed reached signal	10 to 6000	RPM	1000	Immediate	During running	S	350
H06-19	Threshold of zero speed output signal	1 to 6000	RPM	10	Immediate	During running	S	351

Group H07: Torque Control Parameters

Torque reference 100% corresponds to rated motor torque.

Function Code	Parameter Name	Setting Range	Unit	Default	Effective Time	Property	Control Mode	Page
H07-00	Main torque reference A source	0: Digital setting (H07-03) 1: AI1 2: AI2	-	0	Immediate	At stop	T	352
H07-01	Auxiliary torque reference B source	0: Digital setting (H07-03) 1: AI1 2: AI2	-	1	Immediate	At stop	T	352
H07-02	Torque reference source	0: Main torque reference A source 1: Auxiliary torque reference B source 2: A + B 3: A/B switchover 4: Communication setting	-	0	Immediate	At stop	T	352
H07-03	Keypad setting value of torque reference	-300.0 to 300.0	%	0	Immediate	During running	T	353
H07-05	Time constant of torque reference filter	0 to 30.00	ms	0.79	Immediate	During running	PST	353
H07-06	2nd time constant of torque reference filter	0 to 30.00	ms	0.79	Immediate	During running	PST	353
H07-07	Torque limit source	0: Internal positive/negative torque limit 1: External positive/negative torque limit (via P-CL, N-CL) 2: T-LMT as external torque limit 3: Minimum of external positive/negative torque and external T-LMT as torque limit (via P-CL, N-CL) 4: Switchover between internal positive/negative torque limit and T-LMT torque limit (via P-CL, N-CL)	-	0	Immediate	At stop	PST	354
H07-08	T-LMT selection	1: AI1 2: AI2	-	2	Immediate	At stop	PST	354
H07-09	Internal positive torque limit	0.0 to 300.0	%	300.0	Immediate	During running	PST	355
H07-10	Internal negative torque limit	0.0 to 300.0	%	300.0	Immediate	During running	PST	355

Function Code	Parameter Name	Setting Range	Unit	Default	Effective Time	Property	Control Mode	Page
H07-11	External positive torque limit	0.0 to 300.0	%	300.0	Immediate	During running	PST	355
H07-12	External negative torque limit	0.0 to 300.0	%	300.0	Immediate	During running	PST	355
H07-17	Speed limit source	0: Internal speed limit (in torque control) 1: V-LMT as external speed limit 2: Speed limit selected via DI	-	0	Immediate	During running	T	355
H07-18	V-LMT selection	1: AI1 2: AI2	-	1	Immediate	During running	T	356
H07-19	Positive speed limit/1st speed limit in torque control	0 to 6000	RPM	3000	Immediate	During running	T	356
H07-20	Negative speed limit/2nd speed limit in torque control	0 to 6000	RPM	3000	Immediate	During running	T	356
H07-21	Base value for torque reached	0.0 to 300.0	%	0.0	Immediate	During running	PST	356
H07-22	Threshold of torque reached valid	0.0 to 300.0	%	20.0	Immediate	During running	PST	356
H07-23	Threshold of torque reached invalid	0.0 to 300.0	%	10.0	Immediate	During running	PST	356
H07-40	Speed limit window in the torque control mode	0.5 to 30.0	ms	1.0	Immediate	During running	T	357

Group H08: Gain Parameters

Function Code	Parameter Name	Setting Range	Unit	Default	Effective Time	Property	Control Mode	Page
H08-00	Speed loop gain	0.1 to 2000.0	Hz	25.0	Immediate	During running	PS	358
H08-01	Time constant of speed loop integration	0.15 to 512.00	ms	31.83	Immediate	During running	PS	358
H08-02	Position loop gain	0.0 to 2000.0	Hz	40.0	Immediate	During running	P	358
H08-03	2nd gain of speed loop	0.1 to 2000.0	Hz	40.0	Immediate	During running	PS	358
H08-04	2nd time constant of speed loop integration	0.15 to 512.00	ms	40.00	Immediate	During running	PS	358
H08-05	2nd gain of position loop	0.0 to 2000.0	Hz	64.0	Immediate	During running	P	358

Function Code	Parameter Name	Setting Range	Unit	Default	Effective Time	Property	Control Mode	Page
H08-08	2nd gain mode setting	0: Always use the first gain, P/PI switched over via DI 1: First gain and second gain switched over according to the setting of H08-09	-	1	Immediate	During running	PST	359
H08-09	Gain switchover condition	0: Fixed at 1st gain (PS) 1: Switched over via DI (PS) 2: Torque reference being large (PS) 3: Speed reference being large (PS) 4: Speed reference change rate being large (PS) 5: Speed reference high-speed low-speed thresholds (PS) 6: Position deviation being large (P) 7: Position reference available (P) 8: Positioning completed (P) 9: Motor speed being large (P) 10: Position reference available + motor speed (P)	-	0	Immediate	During running	PST	359
H08-10	Gain switchover delay	0.0 to 1000.0	ms	5.0	Immediate	During running	PST	362
H08-11	Gain switchover level	0 to 20000	*	50	Immediate	During running	PST	362
H08-12	Gain switchover hysteresis	0 to 20000	*	30	Immediate	During running	PST	362
H08-13	Position gain switchover time	0.0 to 1000.0	ms	3.0	Immediate	During running	P	362
H08-15	Load inertia ratio	0.00 to 120.00	Times	1.00	Immediate	During running	PST	363
H08-18	Time constant of speed feedforward filter	0.00 to 64.00	ms	0.50	Immediate	During running	P	363
H08-19	Speed feedforward gain	0.0 to 100.0	%	0.0	Immediate	During running	P	363

Function Code	Parameter Name	Setting Range	Unit	Default	Effective Time	Property	Control Mode	Page
H08-20	Time constant of torque feedforward filter	0.00 to 64.00	ms	0.50	Immediate	At stop	PS	363
H08-21	Torque feedforward gain	0.0 to 200.0	%	0.0	Immediate	During running	PS	364
H08-22	Speed feedback filter	0: Disabled 1: Mean filter of 2 speed feedbacks 2: Mean filter of 4 speed feedbacks 3: Mean filter of 8 speed feedbacks 4: Mean filter of 16 speed feedbacks	-	0	Immediate	At stop	PS	364
H08-23	Cutoff frequency of speed feedback low-pass filter	100 to 4000	Hz	4000	Immediate	During running	PS	364
H08-24	PDFF control coefficient	0.0 to 100.0	-	100.0	Immediate	During running	PS	364

*: Based on switchover condition

Group H09: Automatic Gain Tuning parameters

Function Code	Parameter Name	Setting Range	Unit	Default	Effective Time	Property	Control Mode	Page
H09-00	Automatic gain tuning mode selection	0: Disabled, gain parameters are set manually 1: Automatic gain tuning mode, gain parameters tuned automatically based on stiffness table 2: Positioning mode, gain parameters tuned automatically based on stiffness table	-	0	Immediate	During running	PST	365
H09-01	Stiffness level selection	0 to 31	-	12	Immediate	During running	PST	365

Function Code	Parameter Name	Setting Range	Unit	Default	Effective Time	Property	Control Mode	Page
H09-02	Mode selection of adaptive notch	0: Parameters not updated 1: Only one notch (3rd notch) valid, parameters updated in real time 2: Both notches (3rd and 4th notches) valid, parameters updated in real time 3: Only detect resonance frequency (displayed in H09-24) 4: Clear 3rd and 4th notches, restore parameters to default setting	-	0	Immediate	During running	PST	365
H09-03	Online inertia auto-tuning mode	0: Disabled 1: Enabled, update slowly 2: Enabled, always update 3: Enabled, update quickly	-	0	Immediate	During running	RST	366
H09-04	Suppression mode of low-frequency resonance	0: Set low-frequency resonance suppression filter parameters (H09-38 and H09-39) manually. 1: Set low-frequency resonance suppression filter parameters (H09-38 and H09-39) automatically.	-	0	Immediate	During running	P	366
H09-05	Offline inertia auto-tuning mode	0: Positive and negative triangular wave mode 1: Jog mode	-	0	Immediate	At stop	PST	366
H09-06	Maximum speed for inertia auto-tuning	100 to 1000	RPM	500	Immediate	At stop	PST	366
H09-07	Time constant of accelerating to max. speed for inertia auto-tuning	20 to 800	ms	125	Immediate	At stop	PST	367
H09-08	Interval after an inertia auto-tuning	50 to 10000	ms	800	Immediate	At stop	PST	367
H09-09	Motor revolutions for an inertia auto-tuning	0.00 to 2.00	r	-	-	At display	PST	367
H09-12	1st notch frequency	50 to 4000	Hz	4000	Immediate	During running	PS	367
H09-13	1st notch width level	0 to 20	-	2	Immediate	During running	PS	367

Function Code	Parameter Name	Setting Range	Unit	Default	Effective Time	Property	Control Mode	Page
H09-14	1st notch depth level	0 to 99	-	0	Immediate	During running	PS	367
H09-15	2nd notch frequency	50 to 4000	Hz	4000	Immediate	During running	PS	368
H09-16	2nd notch width level	0 to 20	-	2	Immediate	During running	PS	368
H09-17	2nd notch depth level	0 to 99	-	0	Immediate	During running	PS	368
H09-18	3rd notch frequency	50 to 4000	Hz	4000	Immediate	During running	PS	368
H09-19	3rd notch width level	0 to 20	-	2	Immediate	During running	PS	368
H09-20	3rd notch depth level	0 to 99	-	0	Immediate	During running	PS	368
H09-21	4th notch frequency	50 to 4000	Hz	4000	Immediate	During running	PS	368
H09-22	4th notch width level	0 to 20	-	2	Immediate	During running	PS	368
H09-23	4th notch depth level	0 to 99	-	0	Immediate	During running	PS	369
H09-24	Obtained resonance frequency	0 to 2	Hz	0	-	At display	PS	369
H09-30	Torque disturbance compensation gain	0.0 to 100.0	%	0.0	Immediate	During running	PS	369
H09-31	Time constant of torque disturbance observer filter	0.00 to 25.00	ms	0.50	Immediate	During running	PS	369
H09-38	Frequency of low-frequency resonance	1.0 to 100.0	Hz	100.0	Immediate	During running	P	369
H09-39	Filter setting of low-frequency resonance	0 to 10	-	2	Immediate	During running	P	370

Group H0A: Fault and Protection Parameters

Function Code	Parameter Name	Setting Range	Unit	Default	Effective Time	Property	Control Mode	Page
H0A-00	Power input phase loss protection	0: Enable faults and inhibit warnings 1: Enable faults and warnings 2: Inhibit faults and warnings	-	0	Immediate	During running	-	371

Function Code	Parameter Name	Setting Range	Unit	Default	Effective Time	Property	Control Mode	Page
H0A-03	Retentive at power failure	0: Disabled 1: Enabled	-	0	Immediate	During running	-	371
H0A-04	Motor overload protection gain	50 to 300	%	100	Immediate	At stop	-	372
H0A-08	Overspeed threshold	0 to 10000	RPM	0	Immediate	During running	PST	372
H0A-09	Maximum position pulse frequency	100 to 4000	kHz	4000	Immediate	At stop	P	372
H0A-10	Threshold of position deviation excess	1 to 1073741824	Encoder unit	3145728	Immediate	During running	P	372
H0A-12	Runaway protection function	0: Disabled 1: Enabled	-	1	Immediate	During running	PST	372
H0A-16	Position deviation threshold for low-frequency resonance suppression	1 to 1000	Encoder unit	5	Immediate	During running	P	373
H0A-19	DI8 filter time constant	0 to 255	25ns	80	Power-on again	At stop	-	373
H0A-20	DI9 filter time constant	0 to 255	25ns	80	Power-on again	At stop	-	373
H0A-24	Filter time constant of low-speed pulse input terminal	0 to 255	25ns	30	Power-on again	At stop	P	373
H0A-25	Filter time constant of speed feedback display	0 to 5000	ms	50	Immediate	At stop	-	374
H0A-26	Motor overload shielding	0: Motor overload detection is enabled 1: Detection of motor overload warning (Er.909) and fault (Er.620) is disabled	-	0	Immediate	At stop	-	374
H0A-27	Filter time constant of speed DO	0 to 5000	ms	10	Immediate	At stop	-	374
H0A-28	Filter time constant of quadrature encoder	0 to 255	25ns	30	Power-on again	At stop	-	374

Function Code	Parameter Name	Setting Range	Unit	Default	Effective Time	Property	Control Mode	Page
H0A-30	Filter time constant of high-speed pulse input terminal	0 to 255	25ns	3	Power-on again	At stop	P	374
H0A-32	Time threshold for locked rotor over-temperature protection	10 to 65535	ms	200	Immediate	During running	-	375
H0A-33	Locked rotor over-temperature protection	0: Shield detection (Er.630) 1: Enable detection (Er.630)	-	1	Immediate	During running	-	375
H0A-36	Encoder multi-turn overflow fault selection	0: Not shield fault 1: Shield fault	-	0	Immediate	At stop	ALL	375
H0A-40	Soft limit function	0: Disabled 1: Enabled immediately after power-on 2: Enabled after homing	1	0	Immediate	At stop	PST	375
H0A-41	Soft limit maximum value	-2147483648 to 2147483647	Reference unit	2147483647	Immediate	At stop	PST	375
H0A-42	Soft limit minimum value	-2147483648 to 2147483647	Reference unit	-2147483648	Immediate	At stop	PST	376

Group H0B: Monitoring Parameters

Function Code	Parameter Name	Setting Range	Unit	Default	Effective Time	Property	Control Mode	Page
H0B-00	Actual motor speed	-	RPM	-	-	At display	PST	376
H0B-01	Speed reference	-	RPM	-	-	At display	PS	376
H0B-02	Internal torque reference	-	%	-	-	At display	PST	376
H0B-03	Monitored DI states	-	-	-	-	At display	PST	376
H0B-05	Monitored DO states	-	-	-	-	At display	PST	377
H0B-07	Absolute position counter	-	Reference unit	-	-	At display	PST	377
H0B-09	Mechanical angle	-	Encoder unit	-	-	At display	PST	377
H0B-10	Electric angle	-	°	-	-	At display	PST	378
H0B-11	Speed corresponding to input position reference	-	RPM	-	-	At display	P	378

Function Code	Parameter Name	Setting Range	Unit	Default	Effective Time	Property	Control Mode	Page
H0B-12	Average load ratio	-	%	-		At display	PST	378
H0B-13	Input position reference counter	-	Reference unit	-	-	At display	P	378
H0B-15	Encoder position deviation counter	-	Encoder unit	-	-	At display	P	378
H0B-17	Feedback pulse counter	-	Encoder unit	-	-	At display	PST	379
H0B-19	Total power-on time	-	s	-	-	At display	PST	379
H0B-21	AI1 sampling voltage	-	V	-	-	At display	PST	379
H0B-22	AI2 sampling voltage	-	V	-	-	At display	PST	379
H0B-24	Phase current effective value	-	A	-	-	At display	PST	379
H0B-26	Bus voltage	-	V	-	-	At display	PST	379
H0B-27	Module temperature	-	°C	-	-	At display	PST	380
H0B-33	Fault record	0: Current fault 1: Latest fault 2: Last 2nd fault 9: Last 9nd fault	-	0	Immediate	During running	PST	380
H0B-34	Fault code of selected fault record	-	-	-	-	At display	PST	380
H0B-35	Time stamp upon displayed fault	-	s	-	-	At display	PST	380
H0B-37	Motor speed upon displayed fault	-	RPM	-	-	At display	PST	380
H0B-38	Motor phase U current upon displayed fault	-	A	-	-	At display	PST	380
H0B-39	Motor phase V current upon displayed fault	-	A	-	-	At display	PST	380
H0B-40	Bus voltage upon displayed fault	-	V	-	-	At display	PST	381
H0B-41	Input terminal state upon displayed fault	-	-	-	-	At display	PST	381
H0B-42	Output terminal state upon displayed fault	-	-	-	-	At display	PST	381
H0B-53	Position deviation counter	-	Reference unit	-	-	At display	P	381
H0B-55	Actual motor speed	-	RPM	-	-	At display	PST	381
H0B-58	Mechanical absolute position (low 32 bits)	-	Encoder unit	0	-	At display	ALL	381

Function Code	Parameter Name	Setting Range	Unit	Default	Effective Time	Property	Control Mode	Page
H0B-60	Mechanical absolute position (high 32 bits)	-	Encoder unit	0	-	At display	ALL	381
H0B-64	Real-time input position reference counter	-	Reference unit	-	-	At display	PST	382
H0B-70	Number of absolute encoder turns	-	r	0	-	At display	ALL	382
H0B-71	Position of absolute encoder within one turn	-	Encoder unit	0	-	At display	ALL	382
H0B-77	Absolute position (low 32 bits) of absolute encoder)	-	Encoder unit	0	-	At display	ALL	382
H0B-79	Absolute position (high 32 bits) of absolute encoder	-	Encoder unit	0	-	At display	ALL	382
H0B-81	Rotating load single-turn position (low 32 bits)	-	Encoder unit	0	-	At display	ALL	382
H0B-83	Rotating load single-turn position (high 32 bits)	-	Encoder unit	0	-	At display	ALL	382
H0B-85	Rotating load single-turn position	-	Encoder unit	0	-	At display	ALL	383

Group H0C: Communication Parameters

Function Code	Parameter Name	Setting Range	Unit	Default	Effective Time	Property	Control Mode	Page
H0C-00	Servo axis address	0: Broadcast address 1 to 247	-	1	Immediate	During running	PST	383
H0C-02	Serial baud rate	0: 2400 Kbps 1: 4800 Kbps 2: 9600 Kbps 3: 19200 Kbps 4: 38400 Kbps 5: 57600 Kbps	-	5	Immediate	During running	PST	383
H0C-03	Modbus data format	0: No check, 2 stop bits 1: Even parity check, 1 stop bit 2: Odd parity check, 1 stop bit 3: No check, 1 stop bit	-	0	Immediate	During running	PST	383

Function Code	Parameter Name	Setting Range	Unit	Default	Effective Time	Property	Control Mode	Page
H0C-08	CAN communication rate	0: 20 K 1: 50 K 2: 100 K 3: 125 K 4: 250 K 5: 500 K 6: 1 M 7: 1 M	-	5	Immediate	During running	PST	384
H0C-09	Communication VDI	0: Disabled 1: Enabled	-	0	Immediate	At stop	PST	384
H0C-10	VDI default value after power-on	Bit0: VDI1 default value Bit15: VDI16 default value	-	0	Power-on again	During running	PST	384
H0C-11	Communication VDO	0: Disabled 1: Enabled	-	0	Immediate	At stop	PST	385
H0C-12	Default level of VDO allocated with function 0	Bit0: VDO1 default value Bit15: VDO16 default value	-	0	Immediate	At stop	PST	385
H0C-13	Update function code values written via communication to EEPROM	0: Not update the function codes written via communication to EEPROM 1: Update the function codes written via communication, except groups H0B and H0D to EEPROM	-	1	Immediate	During running	PST	386

Function Code	Parameter Name	Setting Range	Unit	Default	Effective Time	Property	Control Mode	Page
H0C-14	Modbus error code	New protocol: 0x0001: Illegal command code 0x0002: Illegal data address 0x0003: Illegal data 0x0004: Slave station device fault Old protocol: 0x0002: Command code not being 0x03/0x06/0x10 0x0004: CRC checksum received and calculated by servo different from checksum in data frame 0x0008: Accessed function code not exist 0x0010: Written function code value exceed limits 0x0080: Written function code modifiable only in stop state but servo being in running state	1	-	-	At display	-	387
H0C-25	Modbus response delay	0 to 5000	ms	1	Immediate	During running	PST	387
H0C-26	Modbus communication data sequence	0: High 16 bits before low 16 bits 1: Low 16 bits before high 16 bits	1	1	Immediate	During running	PST	387
H0C-30	Modbus error frame format	0: Old protocol 1: New protocol (standard)	1	1	Immediate	During running	PST	387

Group H0D: Auxiliary Function Parameters

Function Code	Parameter Name	Setting Range	Unit	Default	Effective Time	Property	Control Mode	Page
H0D-00	Software reset	0: Disabled 1: Enabled	-	0	Immediate	At stop	-	388
H0D-01	Fault reset	0: Disabled 1: Enabled	-	0	Immediate	At stop	-	388
H0D-02	Offline inertia auto-tuning enable	-	-	-	Immediate	During running	-	388
H0D-03	Reserved parameter	-	-	-	-	-	-	389
H0D-05	Emergency stop	0: Disabled 1: Enabled, stop mode determined in H02-05	-	0	Immediate	During running	-	389

Function Code	Parameter Name	Setting Range	Unit	Default	Effective Time	Property	Control Mode	Page
H0D-10	Analog automatic adjustment	0: Disabled 1: AI1 adjustment 2: AI2 adjustment	-	0	Immediate	At stop	-	389
H0D-11	Jog function	With filter	-	-	-	-	-	389
H0D-17	Forced DI/DO setting	0: Disabled 1: Forced DI enabled, forced DO disabled 2: Forced DO enabled, forced DI disabled 3: Forced DI and DO enabled	-	0	Immediate	During running	-	389
H0D-18	Forced DI level	0 to 0x01FF	-	0x01FF	Immediate	During running	-	390
H0D-19	Forced DO setting	0 to 0x001F	-	0	Immediate	During running	-	390
H0D-20	Absolute encoder reset function	0: Disabled 1: Reset faults 2: Reset faults and multi-turn data	-	0	Immediate	At display	ALL	391

Group H0F: Full Closed-Loop Parameters

Function Code	Parameter Name	Setting Range	Unit	Default	Effective Time	Property	Control Mode	Page
H0F-00	Encoder feedback mode	0 to 2	-	0	Immediate	At stop	P	392
H0F-01	Running direction of external encoder	0: Standard running direction 1: Reverse running direction	-	0	Immediate	At stop	P	392
H0F-04	External encoder pulses per one motor revolution	0 to 1073741824	External encoder unit	10000	Power-on again	At stop	P	392
H0F-08	Full closed-loop position deviation excess threshold	0 to 1073741824	External encoder unit	10000	Immediate	During running	P	393
H0F-10	Full closed-loop position deviation clear setting	0 to 100	r	0	Immediate	During running	P	393
H0F-13	Filter time constant of hybrid vibration suppression	0 to 6553.5	ms	0	Immediate	During running	P	394
H0F-16	Full closed-loop position deviation counter	-1073741824 to 1073741824	External encoder unit	0	-	At display	P	394

Function Code	Parameter Name	Setting Range	Unit	Default	Effective Time	Property	Control Mode	Page
H0F-18	Feedback pulse counter of internal encoder	-1073741824 to 1073741824	Internal encoder unit	0	-	At display	P	394
H0F-20	Feedback pulse counter of external encoder	-1073741824 to 1073741824	External encoder unit	0	-	At display	P	394

Group H11: Multi-Position Function Parameters

Function Code	Parameter Name	Setting Range	Unit	Default	Effective Time	Property	Control Mode	Page
H11-00	Multi-position running mode	0: Stop after running single cycle 1: Cyclic running 2: DI switchover 3: Sequential running	-	1	Immediate	At stop	P	395
H11-01	Number of position reference profile	1 to 16	-	1	Immediate	At stop	P	395
H11-02	Margin processing method	0: Complete the remaining distance 1: Start running again from 1st position	-	0	Immediate	At stop	P	395
H11-03	Time unit	0: ms 1: s	-	0	Immediate	At stop	P	396
H11-04	Displacement reference type	0: Relative displacement reference 1: Absolute displacement reference	-	0	Immediate	At stop	P	396
H11-05	Start position of sequential running	0 to 16	-	0	Immediate	At stop	P	397
H11-12	1st displacement	-1073741824 to 1073741824	Reference unit	10000	Immediate	During running	P	397
H11-14	Maximum running speed of 1st displacement	1 to 6000	RPM	200	Immediate	During running	P	398
H11-15	Acceleration/Deceleration time of 1st displacement	0 to 65535	ms(s)	10	Immediate	During running	P	398
H11-16	Waiting time after 1st displacement	0 to 10000	ms(s)	10	Immediate	During running	P	398
H11-17	2nd displacement	-1073741824 to 1073741824	Reference unit	10000	Immediate	During running	P	-

Function Code	Parameter Name	Setting Range	Unit	Default	Effective Time	Property	Control Mode	Page
H11-19	Maximum running speed of 2nd displacement	1 to 6000	RPM	200	Immediate	During running	P	-
H11-20	Acceleration/Deceleration time of 2nd displacement	0 to 65535	ms(s)	10	Immediate	During running	P	-
H11-21	Waiting time after 2nd displacement	0 to 10000	ms(s)	10	Immediate	During running	P	-
H11-22	3rd displacement	-1073741824 to 1073741824	Reference unit	10000	Immediate	During running	P	-
H11-24	Maximum running speed of 3rd displacement	1 to 6000	RPM	200	Immediate	During running	P	-
H11-25	Acceleration/Deceleration time of 3rd displacement	0 to 65535	ms(s)	10	Immediate	During running	P	-
H11-26	Waiting time after 3rd displacement	0 to 10000	ms(s)	10	Immediate	During running	P	-
H11-27	4th displacement	-1073741824 to 1073741824	Reference unit	10000	Immediate	During running	P	-
H11-29	Maximum running speed of 4th displacement	1 to 6000	RPM	200	Immediate	During running	P	-
H11-30	Acceleration/Deceleration time of 4th displacement	0 to 65535	ms(s)	10	Immediate	During running	P	-
H11-31	Waiting time after 4th displacement	0 to 10000	ms(s)	10	Immediate	During running	P	-
H11-32	5th displacement	-1073741824 to 1073741824	Reference unit	10000	Immediate	During running	P	-
H11-34	Maximum running speed of 5th displacement	1 to 6000	RPM	200	Immediate	During running	P	-
H11-35	Acceleration/Deceleration time of 5th displacement	0 to 65535	ms(s)	10	Immediate	During running	P	-
H11-36	Waiting time after 5th displacement	0 to 10000	ms(s)	10	Immediate	During running	P	-
H11-37	6th displacement	-1073741824 to 1073741824	Reference unit	10000	Immediate	During running	P	-
H11-39	Maximum running speed of 6th displacement	1 to 6000	RPM	200	Immediate	During running	P	-
H11-40	Acceleration/Deceleration time of 6th displacement	0 to 65535	ms(s)	10	Immediate	During running	P	-

Function Code	Parameter Name	Setting Range	Unit	Default	Effective Time	Property	Control Mode	Page
H11-41	Waiting time after 6th displacement	0 to 10000	ms(s)	10	Immediate	During running	P	-
H11-42	7th displacement	-1073741824 to 1073741824	Reference unit	10000	Immediate	During running	P	-
H11-44	Maximum running speed of 7th displacement	1 to 6000	RPM	200	Immediate	During running	P	-
H11-45	Acceleration/Deceleration time of 7th displacement	0 to 65535	ms(s)	10	Immediate	During running	P	-
H11-46	Waiting time after 7th displacement	0 to 10000	ms(s)	10	Immediate	During running	P	-
H11-47	8th displacement	-1073741824 to 1073741824	Reference unit	10000	Immediate	During running	P	-
H11-49	Maximum running speed of 8th displacement	1 to 6000	RPM	200	Immediate	During running	P	-
H11-50	Acceleration/Deceleration time of 8th displacement	0 to 65535	ms(s)	10	Immediate	During running	P	-
H11-51	Waiting time after 8th displacement	0 to 10000	ms(s)	10	Immediate	During running	P	-
H11-52	9th displacement	-1073741824 to 1073741824	Reference unit	10000	Immediate	During running	P	-
H11-54	Maximum running speed of 9th displacement	1 to 6000	RPM	200	Immediate	During running	P	-
H11-55	Acceleration/Deceleration time of 9th displacement	0 to 65535	ms(s)	10	Immediate	During running	P	-
H11-56	Waiting time after 9th displacement	0 to 10000	ms(s)	10	Immediate	During running	P	-
H11-57	10th displacement	-1073741824 to 1073741824	Reference unit	10000	Immediate	During running	P	-
H11-59	Maximum running speed of 10th displacement	1 to 6000	RPM	200	Immediate	During running	P	-
H11-60	Acceleration/Deceleration time of 10th displacement	0 to 65535	ms(s)	10	Immediate	During running	P	-
H11-61	Waiting time after 10th displacement	0 to 10000	ms(s)	10	Immediate	During running	P	-
H11-62	11th displacement	-1073741824 to 1073741824	Reference unit	10000	Immediate	During running	P	-

Function Code	Parameter Name	Setting Range	Unit	Default	Effective Time	Property	Control Mode	Page
H11-64	Maximum running speed of 11th displacement	1 to 6000	RPM	200	Immediate	During running	P	-
H11-65	Acceleration/Deceleration time of 11th displacement	0 to 65535	ms(s)	10	Immediate	During running	P	-
H11-66	Waiting time after 11th displacement	0 to 10000	ms(s)	10	Immediate	During running	P	-
H11-67	12th displacement	-1073741824 to 1073741824	Reference unit	10000	Immediate	During running	P	-
H11-69	Maximum running speed of 12th displacement	1 to 6000	RPM	200	Immediate	During running	P	-
H11-70	Acceleration/Deceleration time of 12th displacement	0 to 65535	ms(s)	10	Immediate	During running	P	-
H11-71	Waiting time after 12th displacement	0 to 10000	ms(s)	10	Immediate	During running	P	-
H11-72	13th displacement	-1073741824 to 1073741824	Reference unit	10000	Immediate	During running	P	-
H11-74	Maximum running speed of 13th displacement	1 to 6000	RPM	200	Immediate	During running	P	-
H11-75	Acceleration/Deceleration time of 13th displacement	0 to 65535	ms(s)	10	Immediate	During running	P	-
H11-76	Waiting time after 13th displacement	0 to 10000	ms(s)	10	Immediate	During running	P	-
H11-77	14th displacement	-1073741824 to 1073741824	Reference unit	10000	Immediate	During running	P	-
H11-79	Maximum running speed of 14th displacement	1 to 6000	RPM	200	Immediate	During running	P	-
H11-80	Acceleration/Deceleration time of 14th displacement	0 to 65535	ms(s)	10	Immediate	During running	P	-
H11-81	Waiting time after 14th displacement	0 to 10000	ms(s)	10	Immediate	During running	P	-
H11-82	15th displacement	-1073741824 to 1073741824	Reference unit	10000	Immediate	During running	P	-
H11-84	Maximum running speed of 15th displacement	1 to 6000	RPM	200	Immediate	During running	P	-
H11-85	Acceleration/Deceleration time of 15th displacement	0 to 65535	ms(s)	10	Immediate	During running	P	-

Function Code	Parameter Name	Setting Range	Unit	Default	Effective Time	Property	Control Mode	Page
H11-86	Waiting time after 15th displacement	0 to 10000	ms(s)	10	Immediate	During running	P	-
H11-87	16th displacement	-1073741824 to 1073741824	Reference unit	10000	Immediate	During running	P	-
H11-89	Maximum running speed of 16th displacement	1 to 6000	RPM	200	Immediate	During running	P	-
H11-90	Acceleration/Deceleration time of 16th displacement	0 to 65535	ms(s)	10	Immediate	During running	P	-
H11-91	Waiting time after 16th displacement	0 to 10000	ms(s)	10	Immediate	During running	P	-

Group H12: Multi-Speed Function Parameters

Function Code	Parameter Name	Setting Range	Unit	Default	Effective Time	Property	Control Mode	Page
H12-00	Multi-speed running mode	0: Stop after running single cycle 1: Cyclic running 2: DI switchover	-	1	Immediate	At stop	S	399
H12-01	Number of speed reference profile	1 to 16	-	16	Immediate	At stop	S	399
H12-02	Time unit	0: sec 1: min	-	0	Immediate	At stop	S	399
H12-03	Acceleration time 1	0 to 65535	ms	10	Immediate	At stop	S	400
H12-04	Deceleration time 1	0 to 65535	ms	10	Immediate	At stop	S	400
H12-05	Acceleration time 2	0 to 65535	ms	50	Immediate	At stop	S	400
H12-06	Deceleration time 2	0 to 65535	ms	50	Immediate	At stop	S	400
H12-07	Acceleration time 3	0 to 65535	ms	100	Immediate	At stop	S	400
H12-08	Deceleration time 3	0 to 65535	ms	100	Immediate	At stop	S	400
H12-09	Acceleration time 4	0 to 65535	ms	150	Immediate	At stop	S	400
H12-10	Deceleration time 4	0 to 65535	ms	150	Immediate	At stop	S	400
H12-20	1st speed reference	-6000 to 6000	RPM	0	Immediate	At stop	S	400
H12-21	Running time of 1st speed reference	0 to 6553.5	s(min)	5.0	Immediate	At stop	S	401

Function Code	Parameter Name	Setting Range	Unit	Default	Effective Time	Property	Control Mode	Page
H12-22	Acceleration/ deceleration time of 1st speed reference	0: No acceleration/ deceleration time 1: Acceleration/ Deceleration time 1 2: Acceleration/ Deceleration time 2 3: Acceleration/ Deceleration time 3 4: Acceleration/ Deceleration time 4	-	0	Immediate	At stop	S	401
H12-23	2nd speed reference	-6000 to 6000	RPM	100	Immediate	At stop	S	--
H12-24	Running time of 2nd speed reference	0 to 6553.5	s(min)	5.0	Immediate	At stop	S	-
H12-25	Acceleration/ deceleration time of 2nd speed reference	0: No acceleration/ deceleration time 1: Acceleration/ Deceleration time 1 2: Acceleration/ Deceleration time 2 3: Acceleration/ Deceleration time 3 4: Acceleration/ Deceleration time 4	-	0	Immediate	At stop	S	-
H12-26	3rd speed reference	-6000 to 6000	RPM	300	Immediate	At stop	S	-
H12-27	Running time of 3rd speed reference	0 to 6553.5	s(min)	5.0	Immediate	At stop	S	-
H12-28	Acceleration/ deceleration time of 3rd speed reference	0: No acceleration/ deceleration time 1: Acceleration/ Deceleration time 1 2: Acceleration/ Deceleration time 2 3: Acceleration/ Deceleration time 3 4: Acceleration/ Deceleration time 4	-	0	Immediate	At stop	S	-
H12-29	4th speed reference	-6000 to 6000	RPM	500	Immediate	At stop	S	-
H12-30	Running time of 4th speed reference	0 to 6553.5	s(min)	5.0	Immediate	At stop	S	-
H12-31	Acceleration/ deceleration time of 4th speed reference	0: No acceleration/ deceleration time 1: Acceleration/ Deceleration time 1 2: Acceleration/ Deceleration time 2 3: Acceleration/ Deceleration time 3 4: Acceleration/ Deceleration time 4	-	0	Immediate	At stop	S	-

Function Code	Parameter Name	Setting Range	Unit	Default	Effective Time	Property	Control Mode	Page
H12-32	5th speed reference	-6000 to 6000	RPM	700	Immediate	At stop	S	-
H12-33	Running time of 5th speed reference	0 to 6553.5	s(min)	5.0	Immediate	At stop	S	-
H12-34	Acceleration/ deceleration time of 5th speed reference	0: No acceleration/ deceleration time 1: Acceleration/ Deceleration time 1 2: Acceleration/ Deceleration time 2 3: Acceleration/ Deceleration time 3 4: Acceleration/ Deceleration time 4	-	0	Immediate	At stop	S	-
H12-35	6th speed reference	-6000 to 6000	RPM	900	Immediate	At stop	S	-
H12-36	Running time of 6th speed reference	0 to 6553.5	s(min)	5.0	Immediate	At stop	S	-
H12-37	Acceleration/ deceleration time of 6th speed reference	0: No acceleration/ deceleration time 1: Acceleration/ Deceleration time 1 2: Acceleration/ Deceleration time 2 3: Acceleration/ Deceleration time 3 4: Acceleration/ Deceleration time 4	-	0	Immediate	At stop	S	-
H12-38	7th speed reference	-6000 to 6000	RPM	600	Immediate	At stop	S	-
H12-39	Running time of 7th speed reference	0 to 6553.5	s(min)	5.0	Immediate	At stop	S	-
H12-40	Acceleration/ deceleration time of 7th speed reference	0: No acceleration/ deceleration time 1: Acceleration/ Deceleration time 1 2: Acceleration/ Deceleration time 2 3: Acceleration/ Deceleration time 3 4: Acceleration/ Deceleration time 4	-	0	Immediate	At stop	S	-
H12-41	8th speed reference	-6000 to 6000	RPM	300	Immediate	At stop	S	-
H12-42	Running time of 8th speed reference	0 to 6553.5	s(min)	5.0	Immediate	At stop	S	-

Function Code	Parameter Name	Setting Range	Unit	Default	Effective Time	Property	Control Mode	Page
H12-43	Acceleration/ deceleration time of 8th speed reference	0: No acceleration/ deceleration time 1: Acceleration/ Deceleration time 1 2: Acceleration/ Deceleration time 2 3: Acceleration/ Deceleration time 3 4: Acceleration/ Deceleration time 4	-	0	Immediate	At stop	S	-
H12-44	9th speed reference	-6000 to 6000	RPM	100	Immediate	At stop	S	-
H12-45	Running time of 9th speed reference	0 to 6553.5	s(min)	5.0	Immediate	At stop	S	-
H12-46	Acceleration/ deceleration time of 9th speed reference	0: No acceleration/ deceleration time 1: Acceleration/ Deceleration time 1 2: Acceleration/ Deceleration time 2 3: Acceleration/ Deceleration time 3 4: Acceleration/ Deceleration time 4	-	0	Immediate	At stop	S	-
H12-47	10th speed reference	-6000 to 6000	RPM	-100	Immediate	At stop	S	-
H12-48	Running time of 10th speed reference	0 to 6553.5	s(min)	5.0	Immediate	At stop	S	-
H12-49	Acceleration/ deceleration time of 10th speed reference	0: No acceleration/ deceleration time 1: Acceleration/ Deceleration time 1 2: Acceleration/ Deceleration time 2 3: Acceleration/ Deceleration time 3 4: Acceleration/ Deceleration time 4	-	0	Immediate	At stop	S	-
H12-50	11th speed reference	-6000 to 6000	RPM	-300	Immediate	At stop	S	-
H12-51	Running time of 11th speed reference	0 to 6553.5	s(min)	5.0	Immediate	At stop	S	-

Function Code	Parameter Name	Setting Range	Unit	Default	Effective Time	Property	Control Mode	Page
H12-52	Acceleration/ deceleration time of 11th speed reference	0: No acceleration/ deceleration time 1: Acceleration/ Deceleration time 1 2: Acceleration/ Deceleration time 2 3: Acceleration/ Deceleration time 3 4: Acceleration/ Deceleration time 4	-	0	Immediate	At stop	S	-
H12-53	12th speed reference	-6000 to 6000	RPM	-500	Immediate	At stop	S	-
H12-54	Running time of 12th speed reference	0 to 6553.5	s(min)	5.0	Immediate	At stop	S	-
H12-55	Acceleration/ deceleration time of 12th speed reference	0: No acceleration/ deceleration time 1: Acceleration/ Deceleration time 1 2: Acceleration/ Deceleration time 2 3: Acceleration/ Deceleration time 3 4: Acceleration/ Deceleration time 4	-	0	Immediate	At stop	S	-
H12-56	13th speed reference	-6000 to 6000	RPM	-700	Immediate	At stop	S	-
H12-57	Running time of 13th speed reference	0 to 6553.5	s(min)	5.0	Immediate	At stop	S	-
H12-58	Acceleration/ deceleration time of 13th speed reference	0: No acceleration/ deceleration time 1: Acceleration/ Deceleration time 1 2: Acceleration/ Deceleration time 2 3: Acceleration/ Deceleration time 3 4: Acceleration/ Deceleration time 4	-	0	Immediate	At stop	S	-
H12-59	14th speed reference	-6000 to 6000	RPM	-900	Immediate	At stop	S	-
H12-60	Running time of 14th speed reference	0 to 6553.5	s(min)	5.0	Immediate	At stop	S	-

Function Code	Parameter Name	Setting Range	Unit	Default	Effective Time	Property	Control Mode	Page
H12-61	Acceleration/ deceleration time of 14th speed reference	0: No acceleration/ deceleration time 1: Acceleration/ Deceleration time 1 2: Acceleration/ Deceleration time 2 3: Acceleration/ Deceleration time 3 4: Acceleration/ Deceleration time 4	-	0	Immediate	At stop	S	-
H12-62	15th speed reference	-6000 to 6000	RPM	-600	Immediate	At stop	S	-
H12-63	Running time of 15th speed reference	0 to 6553.5	s(min)	5.0	Immediate	At stop	S	-
H12-64	Acceleration/ deceleration time of 15th speed reference	0: No acceleration/ deceleration time 1: Acceleration/ Deceleration time 1 2: Acceleration/ Deceleration time 2 3: Acceleration/ Deceleration time 3 4: Acceleration/ Deceleration time 4	-	0	Immediate	At stop	S	-
H12-65	16th speed reference	-6000 to 6000	RPM	-300	Immediate	At stop	S	-
H12-66	Running time of 16th speed reference	0 to 6553.5	s(min)	5.0	Immediate	At stop	S	-
H12-67	Acceleration/ deceleration time of 16th speed reference	0: No acceleration/ deceleration time 1: Acceleration/ Deceleration time 1 2: Acceleration/ Deceleration time 2 3: Acceleration/ Deceleration time 3 4: Acceleration/ Deceleration time 4	-	0	Immediate	At stop	S	-

Group H17: VDI/VDO Parameters

Function Code	Parameter Name	Setting Range	Unit	Default	Effective Time	Property	Control Mode	Page
H17-00	VDI1 function selection	0 to 37	-	0	At stop	During running	-	402
H17-01	VDI1 logic selection	0: Valid when logic is 1 1: Valid when logic changes from 0 to 1	-	0	At stop	During running	-	403
H17-02	VDI2 function selection	0 to 37	-	0	At stop	During running	-	-

Function Code	Parameter Name	Setting Range	Unit	Default	Effective Time	Property	Control Mode	Page
H17-03	VDI2 logic selection	0: Valid when logic is 1 1: Valid when logic changes from 0 to 1	-	0	At stop	During running	-	-
H17-04	VDI3 function selection	0 to 37	-	0	At stop	During running	-	-
H17-05	VDI3 logic selection	0: Valid when logic is 1 1: Valid when logic changes from 0 to 1	-	0	At stop	During running	-	-
H17-06	VDI4 function selection	0 to 37	-	0	At stop	During running	-	-
H17-07	VDI4 logic selection	0: Valid when logic is 1 1: Valid when logic changes from 0 to 1	-	0	At stop	During running	-	-
H17-08	VDI5 function selection	0 to 37	-	0	At stop	During running	-	-
H17-09	VDI5 logic selection	0: Valid when logic is 1 1: Valid when logic changes from 0 to 1	-	0	At stop	During running	-	-
H17-10	VDI6 function selection	0 to 37	-	0	At stop	During running	-	-
H17-11	VDI6 logic selection	0: Valid when logic is 1 1: Valid when logic changes from 0 to 1	-	0	At stop	During running	-	-
H17-12	VDI7 function selection	0 to 37	-	0	At stop	During running	-	-
H17-13	VDI7 logic selection	0: Valid when logic is 1 1: Valid when logic changes from 0 to 1	-	0	At stop	During running	-	-
H17-14	VDI8 function selection	0 to 37	-	0	At stop	During running	-	-
H17-15	VDI8 logic selection	0: Valid when logic is 1 1: Valid when logic changes from 0 to 1	-	0	At stop	During running	-	-
H17-16	VDI9 function selection	0 to 37	-	0	At stop	During running	-	-
H17-17	VDI9 logic selection	0: Valid when logic is 1 1: Valid when logic changes from 0 to 1	-	0	At stop	During running	-	-
H17-18	VDI10 function selection	0 to 37	-	0	At stop	During running	-	-
H17-19	VDI10 logic selection	0: Valid when logic is 1 1: Valid when logic changes from 0 to 1	-	0	At stop	During running	-	-
H17-20	VDI11 function selection	0 to 37	-	0	At stop	During running	-	-
H17-21	VDI11 logic selection	0: Valid when logic is 1 1: Valid when logic changes from 0 to 1	-	0	At stop	During running	-	-

Function Code	Parameter Name	Setting Range	Unit	Default	Effective Time	Property	Control Mode	Page
H17-22	VDI12 function selection	0 to 37	-	0	At stop	During running	-	-
H17-23	VDI12 logic selection	0: Valid when logic is 1 1: Valid when logic changes from 0 to 1	-	0	At stop	During running	-	-
H17-24	VDI13 function selection	0 to 37	-	0	At stop	During running	-	-
H17-25	VDI13 logic selection	0: Valid when logic is 1 1: Valid when logic changes from 0 to 1	-	0	At stop	During running	-	-
H17-26	VDI14 function selection	0 to 37	-	0	At stop	During running	-	-
H17-27	VDI14 logic selection	0: Valid when logic is 1 1: Valid when logic changes from 0 to 1	-	0	At stop	During running	-	-
H17-28	VDI15 function selection	0 to 37	-	0	At stop	During running	-	-
H17-29	VDI15 logic selection	0: Valid when logic is 1 1: Valid when logic changes from 0 to 1	-	0	At stop	During running	-	-
H17-30	VDI16 function selection	0 to 37	-	0	At stop	During running	-	-
H17-31	VDI16 logic selection	0: Valid when logic is 1 1: Valid when logic changes from 0 to 1	-	0	At stop	During running	-	-
H17-32	VDO virtual level	-	-	-	-	At display	-	-
H17-33	VDO1 function selection	0 to 19	-	0	At stop	During running	-	-
H17-34	VDO1 logic selection	0: Output 1 when function valid 1: Output 0 when function valid	-	0	At stop	During running	-	-
H17-35	VDO2 function selection	0 to 19	-	0	At stop	During running	-	-
H17-36	VDO2 logic selection	0: Output 1 when function valid 1: Output 0 when function valid	-	0	At stop	During running	-	-
H17-37	VDO3 function selection	0 to 19	-	0	At stop	During running	-	-
H17-38	VDO3 logic selection	0: Output 1 when function valid 1: Output 0 when function valid	-	0	At stop	During running	-	-
H17-39	VDO4 function selection	0 to 19	-	0	At stop	During running	-	-

Function Code	Parameter Name	Setting Range	Unit	Default	Effective Time	Property	Control Mode	Page
H17-40	VDO4 logic selection	0: Output 1 when function valid 1: Output 0 when function valid	-	0	At stop	During running	-	-
H17-41	VDO5 function selection	0 to 19	-	0	At stop	During running	-	-
H17-42	VDO5 logic selection	0: Output 1 when function valid 1: Output 0 when function valid	-	0	At stop	During running	-	-
H17-43	VDO6 function selection	0 to 19	-	0	At stop	During running	-	-
H17-44	VDO6 logic selection	0: Output 1 when function valid 1: Output 0 when function valid	-	0	At stop	During running	-	-
H17-45	VDO7 function selection	0 to 19	-	0	At stop	During running	-	-
H17-46	VDO7 logic selection	0: Output 1 when function valid 1: Output 0 when function valid	-	0	At stop	During running	-	-
H17-47	VDO8 function selection	0 to 19	-	0	At stop	During running	-	-
H17-48	VDO8 logic selection	0: Output 1 when function valid 1: Output 0 when function valid	-	0	At stop	During running	-	-
H17-49	VDO9 function selection	0 to 19	-	0	At stop	During running	-	-
H17-50	VDO9 logic selection	0: Output 1 when function valid 1: Output 0 when function valid	-	0	At stop	During running	-	-
H17-51	VDO10 function selection	0 to 19	-	0	At stop	During running	-	-
H17-52	VDO10 logic selection	0: Output 1 when function valid 1: Output 0 when function valid	-	0	At stop	During running	-	-
H17-53	VDO11 function selection	0 to 19	-	0	At stop	During running	-	-
H17-54	VDO11 logic selection	0: Output 1 when function valid 1: Output 0 when function valid	-	0	At stop	During running	-	-
H17-55	VDO12 function selection	0 to 19	-	0	At stop	During running	-	-

Function Code	Parameter Name	Setting Range	Unit	Default	Effective Time	Property	Control Mode	Page
H17-56	VDO12 logic selection	0: Output 1 when function valid 1: Output 0 when function valid	-	0	At stop	During running	-	-
H17-57	VDO13 function selection	0 to 19	-	0	At stop	During running	-	-
H17-58	VDO13 logic selection	0: Output 1 when function valid 1: Output 0 when function valid	-	0	At stop	During running	-	-
H17-59	VDO14 function selection	0 to 19	-	0	At stop	During running	-	-
H17-60	VDO14 logic selection	0: Output 1 when function valid 1: Output 0 when function valid	-	0	At stop	During running	-	-
H17-61	VDO15 function selection	0 to 19	-	0	At stop	During running	-	-
H17-62	VDO15 logic selection	0: Output 1 when function valid 1: Output 0 when function valid	-	0	At stop	During running	-	-
H17-63	VDO16 function selection	0 to 19	-	0	At stop	During running	-	-
H17-64	VDO16 logic selection	0: Output 1 when function valid 1: Output 0 when function valid	-	0	At stop	During running	-	-

Group H30: Servo Variables Read by Communication

(Invisible on operation panel)

Function Code	Parameter Name	Setting Range	Unit	Default	Effective Time	Property	Control Mode	Page
H30-00	Servo state read by communication	-	-	-	-	Read-only	PST	406
H30-01	DO function state 1 read via communication	-	-	-	-	Read-only	PST	406
H30-02	DO function state 2 read via communication	-	-	-	-	Read-only	PST	406
H30-03	Input pulse signal sampling read via communication	-	-	-	-	At display	PST	407

Group H31: Servo Variables Set via Communication

(Invisible on operation panel)

Function Code	Parameter Name	Setting Range	Unit	Default	Effective Time	Property	Control Mode	Page
H31-00	VDI virtual level set via communication	0 to 65535	-	0	Immediate	During running	PST	408
H31-04	DO state set via communication	0 to 31	-	0	Immediate	During running	PST	409
H31-09	Speed reference set via communication	-6000.000 to 6000.000	RPM	0	Immediate	During running	S	409
H31-11	Torque reference set via communication	-100.000 to 100.000	%	0	Immediate	During running	T	409

DI/DO Function Definitions

No.	Function Symbol	Function Name	Description	Remarks
Input Function Description				
FunIN.1	S-ON	S-ON	Invalid: Servo motor disabled Valid: Servo motor enabled	The logic of the corresponding terminal needs to be set to level valid. The change of the corresponding DI or VDI or terminal logic takes effect only after power-on again.
FunIN.2	ALM-RST	Fault and warning reset (edge valid)	Invalid: Disabled Valid: Enabled	This DI function is edge valid rather than high/low level valid. The servo drive can continue to operate after fault/warning reset. When this function is allocated to a low-speed DI and logic of the ID is level valid, the servo drive will forcibly changes it to edge logic. The valid level change must last for more than 3 ms; otherwise, the fault reset function becomes invalid. Do not allocate this function to high-speed DI. Otherwise, fault/warning reset will be invalid.

No.	Function Symbol	Function Name	Description	Remarks
FunIN.3	GAIN-SEL	Gain switchover	H08-09 = 1: Invalid: Speed control loop being PI control Invalid: Speed control loop being P control H08-09 = 2: Invalid: Fixed at 1st gain Valid: Fixed at 2nd gain	It is recommended that the logic of the corresponding terminal be set to level valid.
FunIN.4	CMD-SEL	Main/ Auxiliary reference switchover	Valid: Current running reference being A Invalid: Current running reference being B	It is recommended that the logic of the corresponding terminal be set to level valid.
FunIN.5	DIR-SEL	Multi- reference direction	Invalid: Default reference direction Valid: Reverse to reference direction	It is recommended that the logic of the corresponding terminal be set to level valid.
FunIN.6	CMD1	Multi- reference switchover 1	Used to select one from the 16 references	It is recommended that the logic of the corresponding terminal be set to level valid.
FunIN.7	CMD2	Multi- reference switchover 2	Used to select one from the 16 references	It is recommended that the logic of the corresponding terminal be set to level valid.
FunIN.8	CMD3	Multi- reference switchover 3	Used to select one from the 16 references	It is recommended that the logic of the corresponding terminal be set to level valid.
FunIN.9	CMD4	Multi- reference switchover 4	Used to select one from the 16 references	It is recommended that the logic of the corresponding terminal be set to level valid.
FunIN.10	M1-SEL	Mode switchover 1	Used to perform switchover between speed control, position control, and torque control based on the selected control mode (H02-00 = 3/4/5).	It is recommended that the logic of the corresponding terminal be set to level valid.
FunIN.11	M2-SEL	Mode switchover 2	Used to perform switchover between speed control, position control, and torque control based on the selected control mode (H02-00 = 6).	It is recommended that the logic of the corresponding terminal be set to level valid.
FunIN.12	ZCLAMP	Zero speed clamp	Valid: Zero speed clamp enabled Invalid: Zero speed clamp disabled	It is recommended that the logic of the corresponding terminal be set to level valid.

No.	Function Symbol	Function Name	Description	Remarks
FunIN.13	INHIBIT	Position reference inhibited	Invalid: The servo drive responds to position references in position control mode. Valid: The servo drive does not respond to any internal or external position reference in position control mode.	The position references include internal and external position references. It is recommended that the logic of the corresponding terminal be set to level valid.
FunIN.14	P-OT	Forward limit switch	Valid: Forward drive inhibited Invalid: Forward drive permitted	When the mechanical movement is outside the movable range, the servo drive implements the function of preventing the motor from sensing the limit switch. It is recommended that the logic of the corresponding terminal be set to level valid.
FunIN.15	N-OT	Reverse limit switch	Valid: Reverse drive inhibited Invalid: Reverse drive permitted	
FunIN.16	P-CL	External positive torque limit	The torque limit source is switched over based on the setting of H07-07. H07-07 = 1: Valid: External positive torque limit enabled Invalid: Internal positive torque limit enabled H07-07 = 3 and AI limit larger than external positive limit Valid: External positive torque limit enabled Invalid: AI torque limit enabled H07-07 = 4: Valid: AI torque limit enabled Invalid: Internal positive torque limit enabled	It is recommended that the logic of the corresponding terminal be set to level valid.

No.	Function Symbol	Function Name	Description	Remarks
FunIN.17	N-CL	External negative torque limit	<p>The torque limit source is switched over based on the setting of H07-07.</p> <p>H07-07 = 1: Valid: External negative torque limit enabled Invalid: Internal negative torque limit enabled</p> <p>H07-07 = 3 and AI limit larger than external negative limit Valid: External negative torque limit enabled Invalid: AI torque limit enabled</p> <p>H07-07 = 4: Valid: AI torque limit enabled Invalid: Internal negative torque limit enabled</p>	It is recommended that the logic of the corresponding terminal be set to level valid.
FunIN.18	JOGCMD+	Forward jog	<p>Valid: Execute reference input Invalid: Not receive reference input</p>	It is recommended that the logic of the corresponding terminal be set to level valid.
FunIN.19	JOGCMD-	Reverse jog	<p>Valid: Input reverse to reference direction Invalid: Reference input stopped</p>	It is recommended that the logic of the corresponding terminal be set to level valid.
FunIN.20	POSSTEP	Step reference	<p>In servo running state Valid: Execute step reference set in H05-05, servo motor running Invalid: Servo motor in locked state</p>	It is recommended that the logic of the corresponding terminal be set to level valid.
FunIN.21	HX1	Handwheel multiplying factor signal 1	<p>HX1 valid, HX2 invalid: X10 HX1 invalid, HX2 valid: X100 Other: X1</p>	It is recommended that the logic of the corresponding terminal be set to level valid.
FunIN.22	HX2	Handwheel multiplying factor signal 2		
FunIN.23	HX_EN	Handwheel signal	<p>Invalid: Handwheel disabled Valid: Handwheel enabled</p>	It is recommended that the logic of the corresponding terminal be set to level valid.
FunIN.24	GEAR_SEL	Electronic gear ratio switchover	<p>Invalid: Electronic gear ratio 1 Valid: Electronic gear ratio 2</p>	It is recommended that the logic of the corresponding terminal be set to level valid.

No.	Function Symbol	Function Name	Description	Remarks
FunIN.25	TOQDirSel	Torque reference direction selection	Valid: Forward direction Invalid: Reverse direction	It is recommended that the logic of the corresponding terminal be set to level valid.
FunIN.26	SPDDirSel	Speed reference direction selection	Valid: Forward direction Invalid: Reverse direction	It is recommended that the logic of the corresponding terminal be set to level valid.
FunIN.27	POSDirSel	Position reference direction selection	Valid: Actual position reference direction same as given position reference direction Invalid: Actual position reference direction opposite to given position reference direction	It is recommended that the logic of the corresponding terminal be set to level valid.
FunIN.28	PosInSen	Multi-position reference enable (edge valid)	Invalid: Disabled, servo motor in locked state Valid: Enabled	It is recommended that the logic of the corresponding terminal be set to level valid.
FunIN.29	XintFree	Position change on fly unlock (edge valid)	Valid: The position change on fly state is unlocked, and the servo drive can respond to other position references. Invalid: The position change on fly signal is retained, and the servo drive does not respond to other position references.	It is recommended that the logic of the corresponding terminal be set to edge valid. If the logic is set to 1 (high level valid), the servo drive forcibly changes it to 2 (rising edge valid). If the logic is set to 0 (low level valid), the servo drive forcibly changes it to 3 (falling edge valid).
FunIN.31	HomeSwitch	Home switch	Invalid: Not triggered Valid: Triggered, current position being home	The logic of the corresponding terminal needs to be set to level valid. Allocate this function to the high-speed DI terminal. If the logic is set to 2 (rising edge valid), the servo drive forcibly changes it to 1 (high level valid). If the logic is set to 3 (falling edge valid), the servo drive forcibly changes it to 0 (low level valid). If the logic is set to 4 (both rising edge and falling edge valid), the servo drive forcibly changes it to 0 (low level valid).

No.	Function Symbol	Function Name	Description	Remarks
FunIN.32	HomingStart	Homing function (edge valid)	Valid: Enabled (the function cannot be enabled repeatedly when running) Invalid: Disabled	It is recommended that the logic of the corresponding terminal be set to edge valid. If the logic is set to 1 (high level valid), the servo drive forcibly changes it to 2 (rising edge valid). If the logic is set to 0 (low level valid), the servo drive forcibly changes it to 3 (falling edge valid).
FunIN.33	XintInhibit	Position change on fly inhibited	Valid: Position change on fly inhibited Invalid: Position change on fly permitted	The logic of the corresponding terminal needs to be set to level valid. If the logic is set to 2 (rising edge valid), the servo drive forcibly changes it to 1 (high level valid). If the logic is set to 3 (falling edge valid), the servo drive forcibly changes it to 0 (low level valid). If the logic is set to 4 (both rising edge and falling edge valid), the servo drive forcibly changes it to 0 (low level valid).
FunIN.34	EmergencyStop	Emergency stop	Valid: Position lock after emergency stop Invalid: Current running state unaffected	It is recommended that the logic of the corresponding terminal be set to level valid.
FunIN.35	ClrPosErr	Position deviation cleared (edge valid)	Valid: Position deviation cleared Invalid: Position deviation not cleared	It is recommended that the logic of the corresponding terminal be set to edge valid. If the logic is set to 1 (high level valid), the servo drive forcibly changes it to 2 (rising edge valid). If the logic is set to 0 (low level valid), the servo drive forcibly changes it to 3 (falling edge valid). It is recommended that this function be allocated to DI8 or DI9.
FunIN.36	V_LmtSel	Internal speed limit source	Valid: H07-20 as internal speed limit (H07-17 = 2) Valid: H07-19 as internal speed limit (H07-17 = 2)	It is recommended that the logic of the corresponding terminal be set to level valid.

No.	Function Symbol	Function Name	Description	Remarks
FunIN.37	PulseInhibit	Pulse input inhibited	When the position reference source is pulse input (H05-00 = 0) in the position control mode: Invalid: Respond to pulse input Valid: Not respond to pulse input	It is recommended that the logic of the corresponding terminal be set to level valid.
Output Function Description				
FunOUT.1	S-RDY	Servo ready	The servo drive is in ready state and can receive the S-ON signal. Valid: Servo drive ready Invalid: Servo drive not ready	Servo not ready: A No. 1 or 2 fault occurs in the servo drive, or the DI emergency stop signal is active.
FunOUT.2	TGON	Motor rotation output	Valid: Motor speed absolute value after filter smaller than H06-16 Invalid: Motor speed absolute value after filter equal to or larger than H06-16	-
FunOUT.3	ZERO	Zero speed signal	Invalid: The absolute deviation between the motor speed feedback and the speed reference is larger than the setting of H06-19. Valid: The absolute deviation between the motor speed feedback and the speed reference is smaller than or equal to the setting of H06-19.	-
FunOUT.4	V-CMP	Speed consistent	In the speed control mode, when the absolute value of the deviation between the motor speed and the speed reference is smaller than the value of H06-17, this signal is active.	-
FunOUT.5	COIN	Positioning completed	In the position control mode, when the position deviation pulses reach the value of H05-21, this signal is active.	-
FunOUT.6	NEAR	Positioning near	In the position control mode, when the position deviation pulses reach the value of H05-22, this signal is active.	-

No.	Function Symbol	Function Name	Description	Remarks
FunOUT.7	C-LT	Torque limit	Confirming torque limit: Valid: Motor torque limited Invalid: Motor torque not limited	-
FunOUT.8	V-LT	Speed limit	Confirming speed limit in torque control: Invalid: Motor speed not reaching the speed limit Valid: Motor speed reaching the speed limit and speed loop built internally based on the speed limit	-
FunOUT.9	BK	Brake output	Brake output: Invalid: The power is on, the brake is applied, and the motor is in position lock state. Valid: The power is off, the brake is released, and the motor can rotate.	-
FunOUT.10	WARN	Warning output	The warning output is active (conducted).	-
FunOUT.11	ALM	Fault output	This signal is valid when a fault occurs.	-
FunOUT.12	ALMO1	3-digit fault code output	A 3-digit fault code is output.	-
FunOUT.13	ALMO2	3-digit fault code output	A 3-digit fault code is output.	-
FunOUT.14	ALMO3	3-digit fault code output	A 3-digit fault code is output.	-
FunOUT.15	Xintcoin	Position change on fly completed	Valid: Position change on fly completed Invalid: Position change on fly not completed	-
FunOUT.16	HomeAttain	Home attaining output	Home attaining state: Valid: Home attaining completed Invalid: Home attaining not completed	-
FunOUT.17	ElecHomeAttain	Electrical home attaining output	Electric home attaining state: Valid: Electrical home attaining completed Invalid: Electrical home attaining not completed	-

No.	Function Symbol	Function Name	Description	Remarks
FunOUT.18	ToqReach	Torque reached	Valid: Absolute value of torque reference reaching setting value Invalid: Absolute value of torque reference smaller than setting value	-
FunOUT.19	V-Arr	Speed reached	Valid: Speed feedback reaches setting value Invalid: Speed feedback smaller than setting value	-

10.5 Version Record

Date	Version	Change Description
Jan. 2016	V0.0	First issue.



Inovance



Monarch

Inovance Technology

Address: No.16, Youxiang Road, Yuexi Town,
Wuzhong District, Suzhou 215104, P. R. China
[http: //www.inovance.cn](http://www.inovance.cn)