



This Datasheet is for the

[IC693MDL930](#)

Isolated Relay Output, N.O., 4 Amp - 8 Point

<http://www.cimtecautomation.com/parts/p-14677-ic693mdl930.aspx>

Provides the wiring diagrams and installation guidelines for this GE Series 90-30 module.

For further information, please contact Qualitrol Technical Support at

1-800-784-9385

support@qualitrol.com

Isolated Relay Output, N.O., 4 Amp - 8 Point IC693MDL930

The *4 Amp Isolated Relay Output* module for the Series 90-30 Programmable Logic Controller provides 8 normally-open relay circuits for controlling output loads provided by the user. The output switching capacity of each circuit is 4 amps. Each output point is isolated from the other points, and each point has a separate common power output terminal. The relay outputs can control a wide range of user-supplied load devices, such as: motor starters, solenoids, and indicators. The user must supply the AC or DC power to operate the field devices connected to this module. There are no fuses on this module.

LED indicators which provide the ON/OFF status of each point are located at the top of the module. The LEDs are arranged in two horizontal rows with eight green LEDs in each row. This module uses the top row labeled A1 through 8 (points 1 through 8); the bottom row is not used. An insert goes between the inside and outside surface of the hinged door. The surface towards the inside of the module (when the hinged door is closed) has circuit wiring information, and circuit identification information can be recorded on the outside surface. The outside left edge of the insert is color-coded red to indicate a high-voltage module. This module can be installed in any I/O slot of a 5 or 10-slot baseplate in a Series 90-30 PLC system.

Table 7-15. Specifications for IC693MDL930

Rated Voltage	24 volts DC, 120/240 volts AC (nominal – see the following table for exceptions)
Operating Voltage	5 to 30 volts DC 5 to 250 volts AC, 50/60 Hz
Outputs per Module	8 isolated outputs
Isolation	1500 volts between field side and logic side 500 volts between groups
Maximum Load †	4 amps resistive maximum per output 2 amps pilot duty per output 20 amps maximum per module for UL installations
Minimum Load	10 mA
Maximum Inrush	5 amps
On Response Time	15 ms maximum
Off Response Time	15 ms maximum
Int. Power Consumption	6 mA (all outputs on) from 5 volt bus on backplane 70 mA (all outputs on) from relay 24V bus on backplane

† Maximum load current is dependent upon ambient temperature as shown in graph on following page.

Refer to Appendix B for product standards and general specifications.

IC693MDL930 Output Module Field Wiring Information

The following figure provides wiring information for connecting user supplied load devices and power source to the 4 amp Relay Output module.

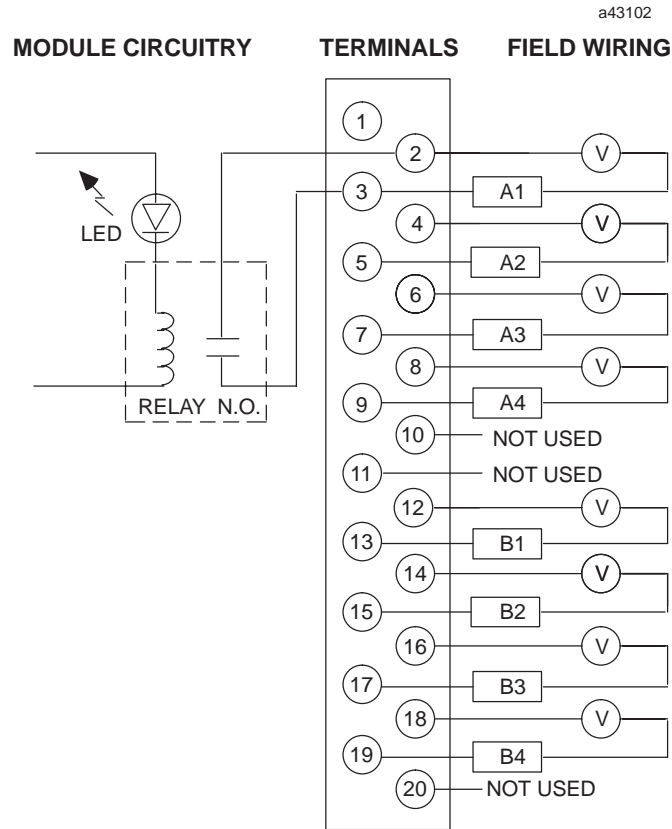

Figure 7-28. IC693MDL930 Output Module Field Wiring

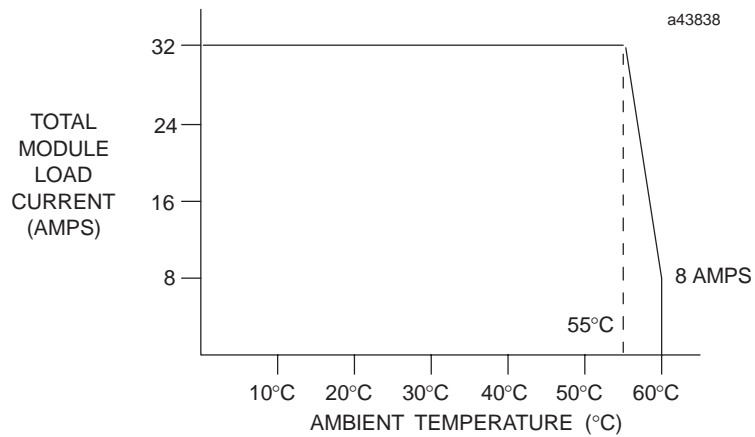

Figure 7-29. Load Current vs. Temperature for IC693MDL930

Table 7-16. Load Current Limitations for IC693MDL930

Operating Voltage	Maximum Current for Load Type		Typical Contact Life (number of Operations)
	Resistive	Lamp or Solenoid †	
24 to 120 VAC	4 amps	2 amps	150,000
24 to 120 VAC	1 amp	.5 amps	500,000
24 to 120 VAC	.1 amps	.05 amps	1,000,000
240 VAC	4 amps	2 amps	50,000
240 VAC	.1 amps	.05 amps	500,000
240 VAC	1 amp	.5 amps	200,000
24 VDC	-	3 amps	50,000
24 VDC	4 amps	2 amps	100,000
24 VDC	1 amp	.5 amps	500,000
24 VDC	.1 amps	.05 amps	1,000,000
125 VDC	.2 amps	.1 amps	300,000

† Assumes a 7 ms time constant

Relay contact life, when switching inductive loads, will approach resistive load contact life if suppression circuits are used. The following figures are examples of typical suppression circuits for AC and DC loads. The 1A, 200V diode shown in the DC load typical suppression example is an industry standard 1N4935. The resistor and capacitor shown for AC load suppression are standard components, available from most electronics distributors.

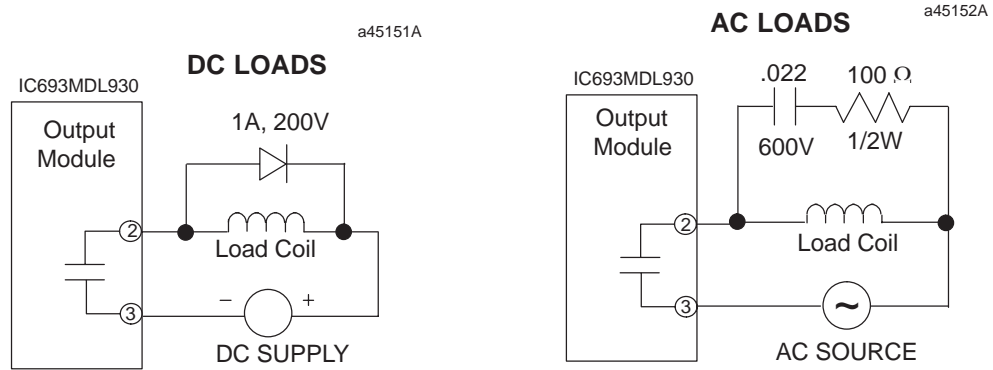

Figure 7-30. Load Suppression Examples for IC693MDL930 Output Module