

SERIES CL - CK - Contactors

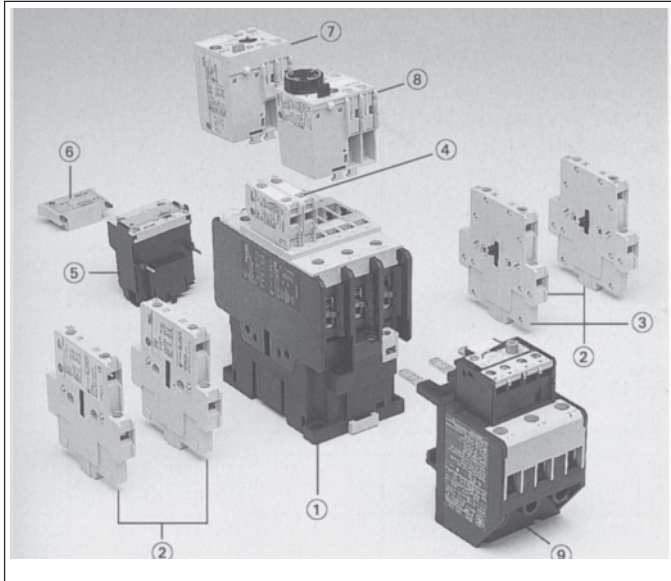

- ① Contactor (see 2.11)
- ② Auxiliary contacts side-mounted (see 2.15)
- ③ Mechanical interlock (see 2.15)
- ④ Auxiliary contacts front-mounted (see 2.15)
- ⑤ Electronic timer block (see 2.16)
- ⑥ Transient voltage suppressor block (see ie 2.16)
- ⑦ Mechanical latch block (see 2.15)
- ⑧ Pneumatic timer block (see 2.15)
- ⑨ Thermal overload relay (see 2.22)

Contactors Series CL

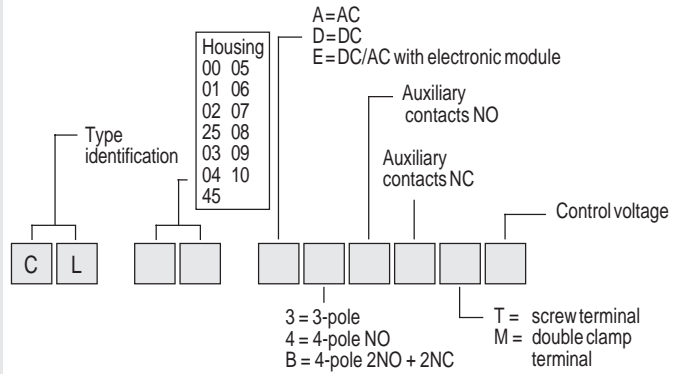
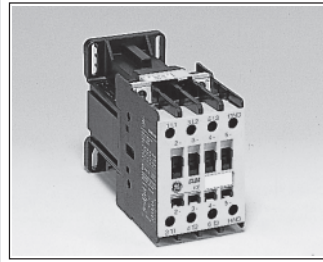

Contactors Series CK

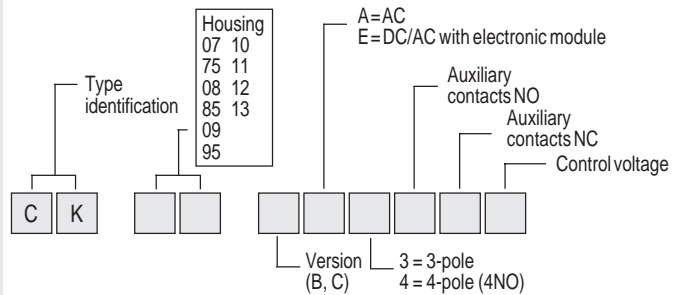
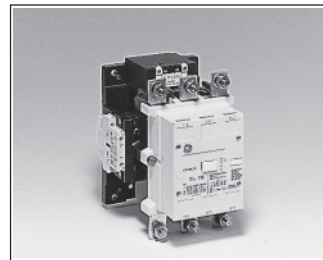

Thermal overload relay RT

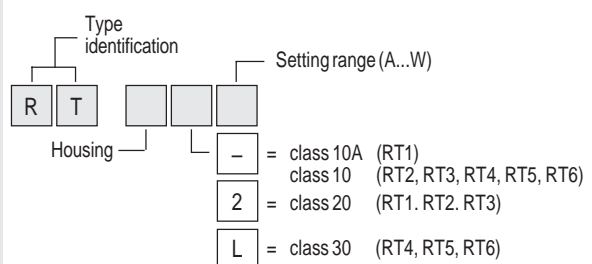



Three-pole contactors from 9 to 105A (AC3)

- Power circuit (AC): up to 690V
- Control circuit:
Alternating current up to 690V AC
- Terminal numbering in accordance with EN 50005 and EN 50012
- Fixing by clipping onto 35 mm DIN rail EN 50022-35 or by screws
- Degree of protection CL00... to CL02... : IP20
CL25... to CL10... : IP10
- Screws protected against accidental contact in accordance with VDE 0106.
- Three coil terminals.
- Accessories:
Mounting possibilities of front/side instantaneous auxiliary contact blocks, timed auxiliary contact blocks, mechanical latch, transient suppressor block and interface modules
- Maximum number of auxiliary contacts:
four for CL00...CL25
six for CL03...CL45
eight for CL06...CL10

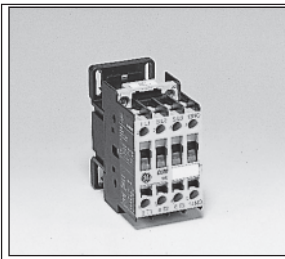

CL00A310TN

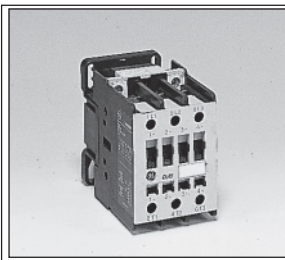

CL45A300MN

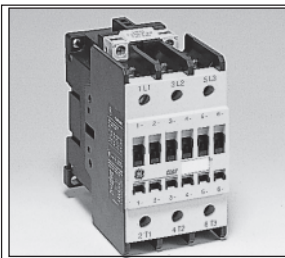

CL07A300MN

Thermal overload relay, see 2.22
 Technical specifications, see 2.34
 Dimensions, see 2.44

Control circuit: alternating current

Max. operat. current		Admissible power AC3				Elec. endur.	Aux. contacts	Cat. no. ⁽¹⁾	Weight	
Non-inductive load	Motors ≤ 440V 3-phase 50/60 Hz AC3	220V 230V	380V 400V	415V 440V	500V	Category AC3				
AC1	A	kW	kW	kW	kW	# ops.				
25	9	2.2	4	4	5.5	2 x 10 ⁶	0 0 1 0 0 1	CL00A300T ♦ CL00A310T ♦ CL00A301T ♦	0.280 0.295 0.295	
25	12	3	5.5	5.5	7.5	2 x 10 ⁶	0 0 1 0 0 1	CL01A300T ♦ CL01A310T ♦ CL01A301T ♦	0.280 0.295 0.295	
32	18	4	7.5	7.5	10	1.7 x 10 ⁶	0 0 1 0 0 1	CL02A300T ♦ CL02A310T ♦ CL02A301T ♦	0.280 0.295 0.295	
45	25	7.5	11	11	15	2 x 10 ⁶	0 0 1 0 0 1	CL25A300T ♦ CL25A310T ♦(2) CL25A301T ♦(2)	0.270 0.285 0.285	
45	25	7.5	12	12	15	2 x 10 ⁶	1 0 0 1	CL03A310M ♦ CL03A301M ♦	0.490 0.490	
60	32	9	16	16	18.5	2 x 10 ⁶	0 0 1 0 0 1	CL04A300M ♦ CL04A310M ♦ CL04A301M ♦	0.500 0.520 0.520	
60	40	11	18.5	22	25	2 x 10 ⁶	0 0 1 1	CL45A300M ♦ CL45A311M ♦(3)	0.490 0.540	
90	50	15	22	25	30	1.8 x 10 ⁶	0 0 1 1	CL06A300M ♦ CL06A311M ♦(3)	1.075 1.105	
110	65	18.5	30	37	40	1.7 x 10 ⁶	0 0 1 1	CL07A300M ♦ CL07A311M ♦(3)	1.090 1.120	
110	80	22	37	45	45	1.5 x 10 ⁶	0 0 1 1	CL08A300M ♦ CL08A311M ♦(3)	1.110 1.130	
140	95	25	45	50	55	1.7 x 10 ⁶	0 0 1 1	CL09A300M ♦ CL09A311M ♦(3)	1.000 1.450	
140	105	30	55	55	65	1.5 x 10 ⁶	0 0 1 1	CL10A300M ♦ CL10A311M ♦(3)	1.440 1.470	
Spare coils							Alternating current	CL00 - CL25 CL03 - CL45 CL06 - CL10	LB1A♦ LB3A♦ LB4A♦	0.063 0.102 0.145

Available coil voltages ⁽¹⁾

Alternating current (V)

♦	C	D	F	G	J	K	M	N	R	U	V	W	X	Y	Z
50Hz		24	42	48	110			220 230	240	380 400		415	440	500	660 690

- (1) To complete the catalogue number, replace the symbol ♦ by the code corresponding to the voltage and frequency of the control circuit.
- (2) Equipped with one block BCLF (see 2.15)
- (3) Equipped with two blocks BCLF (see 2.15)

Three-pole contactors from 9 to 105A (AC3)

- Control circuit :
Direct current up to 440V
- Terminal numbering in accordance with EN 50005 and EN 50012
- Fixing by clipping onto 35 mm DIN rail EN 50022-35 or by screws
- Degree of protection CL00... to CL02... : IP20
CL25... to CL10... : IP10
- Screws protected against accidental contact in accordance with VDE 0106.
- Three coil terminals.
- The types CL...E are also suitable for AC control.
- Accessories:
Mounting possibilities of front/side instantaneous auxiliary contact blocks, timed auxiliary contact blocks, mechanical latch, transient suppressor block and interface modules
- Maximum number of auxiliary contacts:
four for CL00...CL25
six for CL03...CL45
eight for CL06...CL10

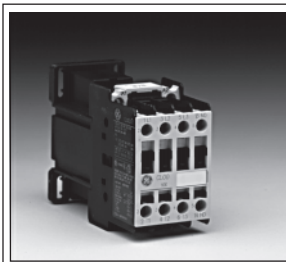
CL00D310TD

Control circuit: direct current

Max. operat. current		Admissible power AC3				Elec. endur.	Aux. contacts	Cat. no. ⁽¹⁾	Weight
Non-inductive load	Motors ≤ 440V	220V	380V	415V	500V	Category AC3			
	3-phase 50/60 Hz AC3	230V	400V	440V					
AC1	A	kW	kW	kW	kW	operations			
25	9	2.2	4	4	5.5	2 x 10 ⁶	1 0	CL00D310T ♦	0.490
							0 1		
25	12	3	5.5	5.5	7.5	2 x 10 ⁶	1 0	CL01D310T ♦	0.490
							0 1		
32	18	4	7.5	7.5	10	1.7 x 10 ⁶	1 0	CL02D310T ♦	0.490
							0 1		
45	25	7.5	11	11	15	2 x 10 ⁶	0 0	CL25D300T ♦	0.480
45	25	7.5	12	12	15	2 x 10 ⁶	1 0	CL03D310M ♦	0.480
							0 1		
60	32	9	16	16	18.5	2 x 10 ⁶	1 0	CL04D310M ♦	0.835
							0 1		
60	40	11	18.5	22	25	2 x 10 ⁶	0 0	CL45D300M ♦	0.825
90	50	15	22	25	30	1.8 x 10 ⁶	0 0	CL06E300M ♦	1.095
110	65	18.5	30	37	40	1.7 x 10 ⁶	0 0	CL07E300M ♦	1.110
110	80	22	37	45	45	1.5 x 10 ⁶	0 0	CL08E300M ♦	1.120
140	95	25	45	50	55	1.7 x 10 ⁶	0 0	CL09E300M ♦	1.440
140	105	30	55	55	65	1.5 x 10 ⁶	0 0	CL10E300M ♦	1.460
Spare coils							(pure DC coil) CL00 - CL25	LB1D ♦	0.205
							(pure DC coil) CL03 - CL45	LB3D ♦	0.276
							(coil + electronic module) CL06 - CL10	LB4E ♦	0.610

Available coil voltages ⁽¹⁾

Direct current (V). For contactors type CL...D / Operating limits: 0.80 ... 1.10 x Us

◆	B	D	E	F	G	H	I	J	K	N	P	R	X
Voltage	12	24		42	48			110	120	220		240	
									125				

Direct current (V). Coil with electronic module for contactors CL...E ⁽²⁾ / Operating limits: 0.80 ... 1.10 x Us

◆	D	F	H	J	N	Y
Voltage	24	42		110	220	
	28	48		125	250	

- (1) To complete the catalogue number, replace the symbol ♦ by the code corresponding to the voltage and frequency of the control circuit.
 (2) Can also be used with alternating current.



Four-pole contactors (4NO) from 25 to 140A (AC1)

- Power circuit (AC): up to 690V
- Control circuit: Alternating current up to 690V AC Direct current up to 440V DC
- Terminal numbering in accordance with EN 50005 and EN 50012
- Fixing by clipping onto 35 mm DIN rail (EN 50022-35) or by screws.
- Degree of protection CL01... to CL02... : IP20 CL03... to CL09... : IP10
- Screws protected against accidental contact in accordance with VDE 0106.
- Three coil terminals.
- The types CL...E are also suitable for AC control.
- Accessories: Mounting possibilities of front/side instantaneous auxiliary contact blocks, timed auxiliary contact blocks, mechanical latch, transient suppressor block and interface modules.



CL01A400TN



CL05A400MN



CL09E400MJ

Thermal overload relay, see 2.21
 Technical specifications, see 2.34
 Dimensions, see 2.44

Control circuit: alternating current

Maximum operating current		Admissible power AC1				Electrical endurance	Control circuit	Power contacts	Cat. no. ⁽¹⁾	Weight
Non-inductive load AC1	AC3	220V	380V	415V	500V	Category AC1				
		230V	400V	440V						
A	A	kW	kW	kW	kW	operations				
25	12	9.5	16.5	18	21.5	1.5 x 10 ⁶	AC	4 0	CL01A400T ♦	0.280
32	18	12	22	23	27.5	1.5 x 10 ⁶	AC	4 0	CL02A400T ♦	0.280
45	25	17	29	32	39	2 x 10 ⁶	AC	4 0	CL03A400M ♦	0.490
60	32	22.5	39.5	43	52	1.5 x 10 ⁶	AC	4 0	CL04A400M ♦	0.500
90	50	34	59	64	78	1.5 x 10 ⁶	AC	4 0	CL05A400M ♦	1.240
110	65	42	72.5	79	95	1.8 x 10 ⁶	AC	4 0	CL07A400M ♦	1.270
140	95	53	92	100	121	1.8 x 10 ⁶	AC	4 0	CL09A400M ♦	1.450
Spare coils								CL01 - CL02	LB1A ♦	0.063
								CL03 - CL04	LB3A ♦	0.102
								CL05 - CL09	LB4A ♦	0.145

Control circuit: direct current

25	12	9.5	16.5	18	21.5	1.5 x 10 ⁶	DC	4 0	CL01D400T ♦	0.490
32	18	12	22	23	27.5	1.5 x 10 ⁶	DC	4 0	CL02D400T ♦	0.490
45	25	17	29	32	39	2 x 10 ⁶	DC	4 0	CL03D400M ♦	0.825
60	32	22.5	39.5	43	52	1.5 x 10 ⁶	DC	4 0	CL04D400M ♦	0.835
90	50	34	59	64	78	1.5 x 10 ⁶	AC/DC	4 0	CL05E400M ♦	1.290
110	65	42	72.5	79	95	1.8 x 10 ⁶	AC/DC	4 0	CL07E400M ♦	1.290
140	95	53	92	100	121	1.8 x 10 ⁶	AC/DC	4 0	CL09E400M ♦	1.500
Spare coils								(pure DC coil) CL00 - CL02	LB1D ♦	0.205
								(pure DC coil) CL03 - CL04	LB3D ♦	0.276
								(coil + electronic module) CL05 - CL09	LB4E ♦	0.610

Available coil voltages ⁽¹⁾

Alternating current (V)

◆	C	D	F	G	H	J	K	M	N	R	S	T	U	V	W	X	Y	Z
50Hz		24	42	48		110	127		220	240			380	400	415	440	500	660
									230									690

Direct current (V). For contactors type CL...D / 0.80 ... 1.10 x Us ⁽⁴⁾

◆	B	D	E	F	G	H	I	J	K	N	P	R	X
Voltage	12	24		42	48			110	120	220		240	
									125				

Direct current (V). Coil with electronic module for contactors type CL...E ⁽³⁾ / 0.80 ... 1.10 x Us ⁽⁴⁾

◆	D	F	H	J	N	Y
Voltage	24	42		110	220	
	28	48		125	250	

- (1) To complete the catalogue number, replace the symbol ♦ by the code corresponding to the voltage and frequency of the control circuit.
 (2) Only for CL00 to CL45.

Four-pole contactors (2NO + 2NC) from 12 to 80A (AC3)

- Power circuit (AC): up to 690V
- Control circuit:
Alternating current up to 690V AC
Direct current up to 440V DC
- Terminal numbering in accordance with EN 50005 and EN 50012
- Fixing by clipping onto 35 mm DIN rail (EN 50022-35) or by screws.
- Degree of protection CL01... to CL02...: IP20
CL03... to CL09...: IP10
- Screws protected against accidental contact in accordance with VDE 0106.
- Three coil terminals.
- The types CL...E are also suitable for AC control.
- Accessories:
Mounting possibilities of front/side instantaneous auxiliary contact blocks, timed auxiliary contact blocks, mechanical latch, transient suppressor block and interface modules.

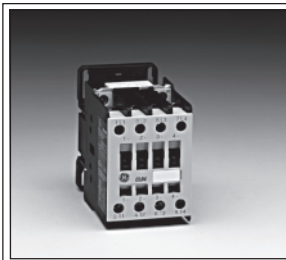

CL01AB00TN



CL05EB00MJ

Control circuit: alternating current

Max. operat. current		Admissible power AC3				Control	Power contacts	Cat. no. ⁽¹⁾	Weight	
Non-inductive load	Motors ≤ 440V, 3-phase 50/60 Hz AC3	220V	380V	415V	500V					
		230V	400V	440V						
AC1	A	kW	kW	kW	kW					
25	12	3	5.5	5.5	7.5	AC	2 2	CL01AB00T ◆	0.280	
32	18	4	7.5	7.5	10	AC	2 2	CL02AB00T ◆	0.280	
45	25	7.5	12	12	15	AC	2 2	CL03AB00M ◆	0.490	
60	32	9	16	16	18.5	AC	2 2	CL04AB00M ◆	0.500	
90	40	11	18.5	22	25	AC	2 2	CL05AB00M ◆	1.240	
110	65	18.5	30	37	40	AC	2 2	CL07AB00M ◆	1.270	
110	80	22	37	45	45	AC	2 2	CL08AB00M ◆	1.270	
Spare coils								CL01 - CL02	LB1A ◆	0.063
								CL03 - CL04	LB3A ◆	0.102
								CL05 - CL08	LB4A ◆	0.145

Control circuit: direct current

25	12	3	5.5	5.5	7.5	DC	2 2	CL01DB00T ◆	0.490	
32	18	4	7.5	7.5	10	DC	2 2	CL02DB00T ◆	0.490	
45	25	7.5	12	12	15	DC	2 2	CL03DB00M ◆	0.825	
60	32	9	16	16	18.5	DC	2 2	CL04DB00M ◆	0.835	
90	40	11	18.5	22	25	DC/AC	2 2	CL05EB00M ◆	1.290	
110	65	18.5	30	37	40	DC/AC	2 2	CL07EB00M ◆	1.320	
110	80	22	37	45	45	DC/AC	2 2	CL08EB00M ◆	1.320	
Spare coils								(pure DC coil) CL00 - CL02	LB1D ◆	0.205
								(pure DC coil) CL03 - CL04	LB3D ◆	0.276
								(coil + electronic module) CL05 - CL08	LB4E ◆	0.610

Available coil voltages ⁽¹⁾

Alternative current (V)

◆	C	D	F	G	H	J	K	M	N	R	S	T	U	V	W	X	Y	Z
50Hz		24	42	48		110	127		220	240			380	400	415	440	500	660
									230								690	

Direct current (V). For contactors type CL...D

◆	B	D	E	F	G	H	I	J	K	N	P	R	X
Voltage	12	24		42	48			110	120	220	230	240	
								125					

Direct current (V). Coil with electronic module for contactors type CL...E ⁽²⁾

◆	D	F	H	J	N	Y
Voltage	24	42		110	220	
	28	48		125	250	

- (1) To complete the catalogue number, replace the symbol ◆ by the code corresponding to the voltage and frequency of the control circuit.
 (2) Only for CL00 to CL45.



BCLF10

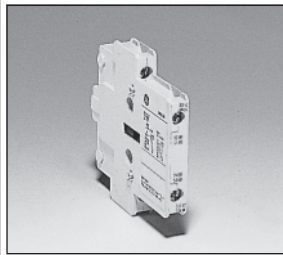

BCLL11

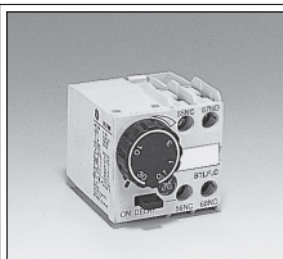

BTLF30C

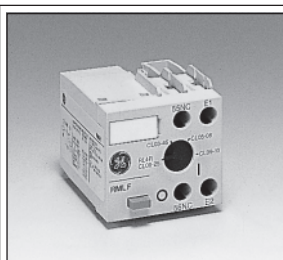

RMLFN

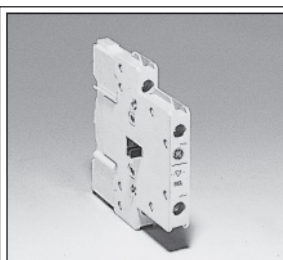

BEL



BEL02

Instantaneous auxiliary contact blocks

- Terminal numbering in accordance with EN 50005 and EN 50012
- Terminals protected against accidental contact in accordance with VDE 0106 T.100, VBG4 : IP20.
- Combinations for contactors and front/side mounted auxiliary contact blocks, see pages K.42 and K.43

For use with	Mounting	Type	Contacts	Cat. no.	Weight
CL00...CL10	Front	one pole	1 0 0 0 0 1 0 0 0 0 1 0 0 0 0 1	BCLF10 BCLF01 BCLF10G BCLF01G	0.015 0.015 0.015 0.015
CL00...CL10	Side	two pole	2 0 0 0 1 1 0 0	BCLL20 BCLL11	0.048 0.048
CL00...CL10	Side ⁽¹⁾	two pole	2 0 0 0 1 1 0 0	BRLL20 BRLL11	0.048 0.048

(1) For combinations of more than 4 front-mounted and 2 side-mounted auxiliary contact blocks

Pneumatic timer auxiliary contact blocks

For use with	Mounting	Type	Contacts	Time	Cat. no.	Weight
CL00...CL10	Front	Delayed ON	1 1 1 1	0.1...30 s. 1.0...60 s.	BTLF30C BTLF60C	0.085 0.085
CL00...CL10	Front	Delayed OFF	1 1 1 1	0.1...30 s. 1.0...60 s.	BTLF30D BTLF60D	0.085 0.085
Sealing cover protection for pneumatic timer					BTLFX	0.001

Mechanical latch blocks

- Terminal numbering in accordance with EN 50005
- Disconnection of the contactor or auxiliary contactor, either using an electrical pulse or manually.
- Terminals protected against accidental contact in accordance with VDE 0106 T.100, VBG4
- Frontal selector allows for adaptation in function of the housing of the contactor.

For use with	Cat. no. ⁽²⁾	Weight
CL00...CL10	RMLF ♦	0.082

(2) To complete the catalogue number, replace the symbol ♦ by the code corresponding to the voltage and frequency of the control circuit.

♦	D	G	HC	J	N	U	Y
50 Hz	24, 32	42, 48		110, 115, 120, 127	220, 230, 240,	380, 400, 415, 440, 480	500, 660/690
DC	32, 36	42, 48		110, 120,	220, 240, 250		

Mechanical and mechanical/electrical interlock

Side mounted to the contactor

For use with	Type	Cat. no.	Weight
CL00...CL45	Mechanical	BELA	0.025
CL05...CL10	Mechanical	BEL	0.025
CL00...CL45	Mech./electrical	BELA02	0.025
CL05...CL10	Mech./electrical	BEL02	0.025

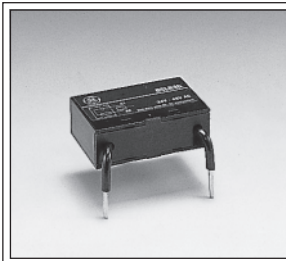
BSLR2R
Transient voltage suppressor block

Directly connected parallel to the coil terminals A1-A2

Control circ.	For use with	Type	Ue	Cat. no.	Weight
AC	CL00...CL45...	R/C	24V...48V	BSLR2G BSLR2K BSLR2R	0.020
			50V...127V		0.020
			130V...240V		0.020
AC	CL05A...CL10A...	R/C	24V...48V	BSLR3G BSLR3K BSLR3R	0.020
			50V...127V		0.020
			130V...240V		0.020
DC	CL...D...	Diode	12V...600V	BSLDZ	0.020
AC/DC	CL...	Varistor	24V...48V	BSLV3G BSLV3K BSLV3R BSLV3U	0.020
			50V...127V		0.020
			130V...240V		0.020
			277V...500V		0.020

BETL45C
Electronic timer module

Directly connected parallel to the coil terminals A1-A2

Control circ.	For use with	Type	Time	Cat. no.	Weight
24-250V AC/DC	CL00 to CL10	Delayed ON	0.1...2 s.	BETL02C BETL45C	0.040
			1.5...45 s.		0.040
		Delayed OFF	0.1...2 s.	BETL02D BETL45D	0.040
			1.5...45 s.		0.040

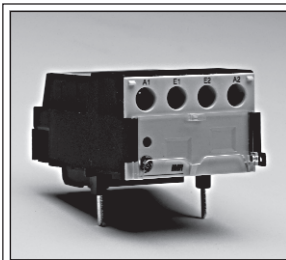
IMRD
Interface module

Directly connected parallel to the coil terminals A1-A2

Control circ.	For use with	Type	Ue (DC)	Cat. no.	Weight
24-250V AC 24-250V DC	CL00 to CL10 CL00 to CL45	Relay	24V	IMRD IMRG	0.060
			48V		0.060
		Relay + forced operation	24V	IMRFD IMRFG	0.050
			48V		0.050
		Solid state	24V	IMSSD	0.045
Auto / Manual / Off control		IMAMS	0.045		

IMRC2R
Transient voltage suppressor block to use with interface modules

To be plugged inside the interface module or inside the electronic timer module.

	For use with	Type	Con. circ. AC/DC	Cat. no.	Weight
	CL00...CL45...	R/C	24V...48V	IMRC2G IMRC2K IMRC2R	0.020
			50V...127V		0.020
			130V...240V		0.020
	CL05A...CL10A...	R/C	24V...48V	IMRC3G IMRC3K IMRC3R	0.020
			50V...127V		0.020
			130V...240V		0.020
	CL...D...	Diode	12V...600V	IMD1Z	0.020
	CL...	Varistor	24V...48V	IMV3G IMV3K IMV3R	0.020
			50V...127V		0.020
			130V...240V		0.020

Pole terminal protector IP xxB

For use with	Mounting	Cat. no.	Weight
CL03...CL04...	Single pole IPxxB	PTP04	
CL45...	Single pole IPxxB	PTP45	
CL05...CL08...	Single pole IPxxB	PTP08	
CL09...CL10...	Single pole IPxxB	PTP10	

Identification

Sheets of labels (10 sheets of 260 labels each)	EAT260	0.050
Labeling plate base (50 pieces in one pack)	SPR	0.001



Coils

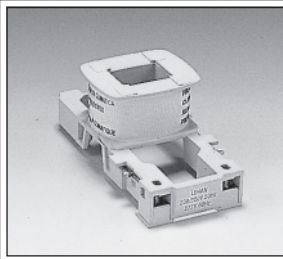

LB4AN

Alternating current

CL...A	For use with	Cat. no. ⁽¹⁾	Weight
	CL00...CL25	LB1A ♦	0.063
	CL03...CL45	LB3A ♦	0.102
	CL05...CL10	LB4A ♦	0.145

Alternating current (V)

♦	C	D	F	G	H	J	K	M	N	R	S	T	U	V	W	X	Y	Z
50Hz		24	42	48		110			220	240			380		415	440	500	660
									230				400					690

(1) To complete the catalogue number, replace the symbol ♦ by the corresponding code.

Direct current ⁽²⁾

CL...D	For use with	Cat. no. ⁽¹⁾	Weight
	CL00...CL25	LB1D ♦	0.205
	CL03...CL45	LB3D ♦	0.276

u	B	D	F	G	H	I	J	K	N	P	R	X
Voltage	12	12	24	42	48			110		220		240

(1) To complete the catalogue number, replace the symbol ♦ by the corresponding code.

Direct current (V) with electronic module (also for use with alternating current) ⁽²⁾

CL...E	For use with	Cat. no. ⁽¹⁾	Weight
	CL05...CL10	LB4E ♦	0.610

♦	D	F	H	J	N	Y
Voltage	24	42	60		220	440
	28	48		125	250	

(1) To complete the catalogue number, replace the symbol ♦ by the corresponding code.

(2) Operating limits 0.80 up to 1.10 x Us.

Contact kits

For use with	Number of sets ⁽¹⁾	Type	Cat. no.	Pack	Weight
CL00...	3	NO	V31200B	1	0.025
CL01...3..., CL01...4...	3	NO	V31201B	1	0.025
CL01...B...	4	2NO-2NC	VB1201B	1	0.035
CL02...3, CL02...4...	3	NO	V31202B	1	0.025
CL02...B...	4	2NO-2NC	VB1202B	1	0.035
CL25...3...	3	NO	V31225B	1	0.035
CL03..., CL03...4...	3	NO	V31203B	1	0.035
CL03...B...	4	2NO-2NC	VB1203B	1	0.050
CL04...3..., CL04...4...	3	NO	V31204B	1	0.035
CL04...B...	4	2NO-2NC	VB1204B	1	0.050
CL45...3...	3	NO	V31245B	1	0.035
CL05...4...	4	NO	V31205B	1	0.080
CL05...B...	4	2NO-2NC	VB1205B	1	0.100
CL06...	3	NO	V31206B	1	0.080
CL07...3..., CL07...4...	3	NO	V31207B	1	0.090
CL07...B...	4	2NO-2NC	VB1207B	1	0.110
CL08...3...	3	NO	V31208B	1	0.090
CL08...B...	4	2NO-2NC	VB1208B	1	0.110
CL09...	3	NO	V31209B	1	0.120
CL10...	3	NO	V31210B	1	0.130

(1) One set consists of two fixed contacts, one moving contact and accessory parts.



Power circuit
Three-pole version

Rated thermal current I _{th} at θ ≤ 55°C	(A)
Rated operational current I _e	(A)
Rated operational voltage U _e	(V)

Four-pole version (4 NO and 2 NO + 2 NC)

Rated thermal current I _{th} at θ ≤ 55°C	(A)
Rated operational voltage U _e	(V)

Three-pole and four-pole version

Rated insulation voltage U _i	(V)
Maximum continuous current AC1	(A)
Frequency limits	(Hz)
Making capacity (RMS) (acc. IEC 947)	(A)
Breaking capacity (RMS) (acc. IEC 947)	(A)
U _e ≤ 400V	(A)
U _e = 500V	(A)
U _e = 690V	(A)
Short-time current	
1 sec.	(A)
5 sec.	(A)
10 sec.	(A)
30 sec.	(A)
1 min.	(A)
3 min.	(A)
Recovery time	(min.)
Protection against short-circuits with fuses	
Coordination type "2"	
aM	(A)
gL-gG	(A)
Without welding	
aM	(A)
gL-gG	(A)
Impedance per pole	(mΩ)
Power dissipation per pole	
AC1	(W)
AC3	(W)
Insulation resistance	
Between adjacent poles	(MΩ)
Between poles and earth	(MΩ)
Between input and output	(MΩ)

CL00	CL01	CL02	CL25	CL03	CL04	CL45		CL06	CL07	CL08	CL09	CL10
25	25	32	45	45	60	60		90	110	110	140	140
9	12	18	25	25	32	40		50	65	80	95	105
690	690	690	690	690	690	690		690	690	690	690	690

	CL01	CL02		CL03	CL04		CL05		CL07	CL08 ⁽¹⁾	CL09 ⁽²⁾	
	25	32		45	60		90		110	110	140	
	690	690		690	690		690		690	690	690	

(1) 2 NO + 2 NC only
(2) 4 NO only

CL00	CL01	CL02	CL25	CL03	CL04	CL45	CL05	CL06	CL07	CL08	CL09	CL10
1000	1000	1000	1000	1000	1000	1000	1000	1000	1000	1000	1000	1000
25	25	32	45	45	60	60	90	90	110	110	140	140
25..400	25..400	25..400	25..400	25..400	25..400	25..400	25..400	25..400	25..400	25..400	25..400	25..400
450	450	450	450	550	550	550	1000	1000	1000	1000	1280	1280
250	250	250	350	450	450	450	920	920	920	920	1050	1050
250	250	250	320	450	450	450	920	920	920	920	1050	1050
130	130	130	170	205	205	205	780	780	780	780	950	950
455	455	570	630	1010	1010	1265	1580	1580	2530	2530	3300	3300
205	205	254	280	450	450	450	565	710	1130	1130	1485	1485
144	144	180	200	320	320	400	500	500	800	800	1050	1050
85	85	104	115	185	185	230	290	290	460	460	600	600
60	60	74	80	130	130	165	205	205	325	325	430	430
35	35	46	50	90	90	100	120	120	185	185	250	250
10	10	10	10	10	10	10	10	10	10	10	10	10
10	12	20	25	25	35	40	40	50	80	80	125	160
25	35	35	50	63	63	63	100	100	160	160	200	200
8	8	16	20	20	20	25	35	40	50	50	80	80
10	10	25	35	35	35	50	80	80	100	100	160	160
2.35	2.35	2.41	1.65	1.28	1.28	0.95	0.85	0.85	0.86	0.86	0.76	0.76
1.47	1.47	2.46	3.34	2.59	4.6	3.42	6.89	6.89	10.4	10.4	14.89	14.89
0.19	0.34	0.78	1.03	0.80	1.31	1.52	1.36	2.12	3.63	5.5	6.86	8.37
>10	>10	>10	>10	>10	>10	>10	>10	>10	>10	>10	>10	>10
>10	>10	>10	>10	>10	>10	>10	>10	>10	>10	>10	>10	>10
>10	>10	>10	>10	>10	>10	>10	>10	>10	>10	>10	>10	>10



Electrical endurance

Category AC1

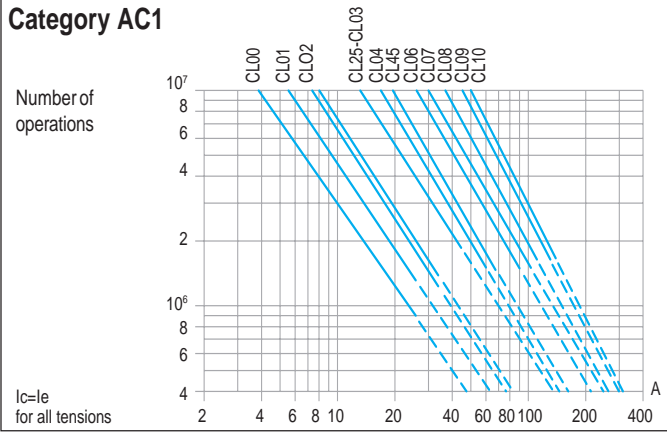

Category AC2

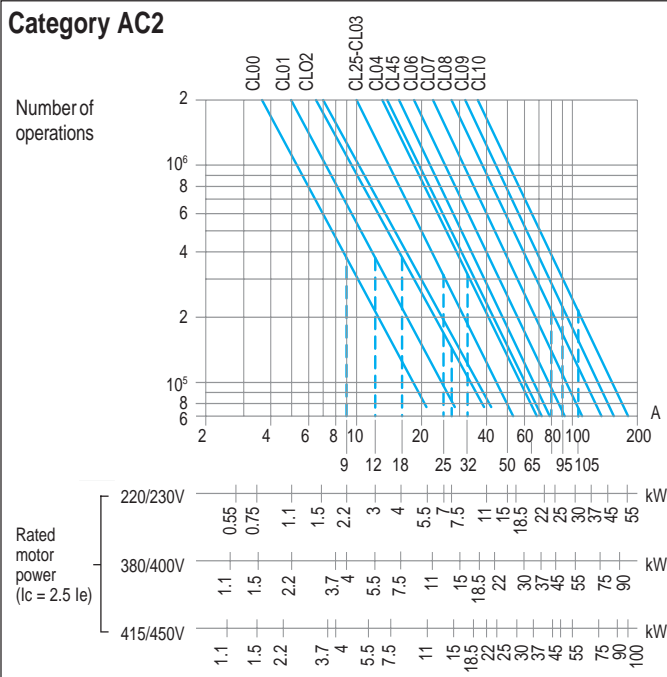

Category AC3

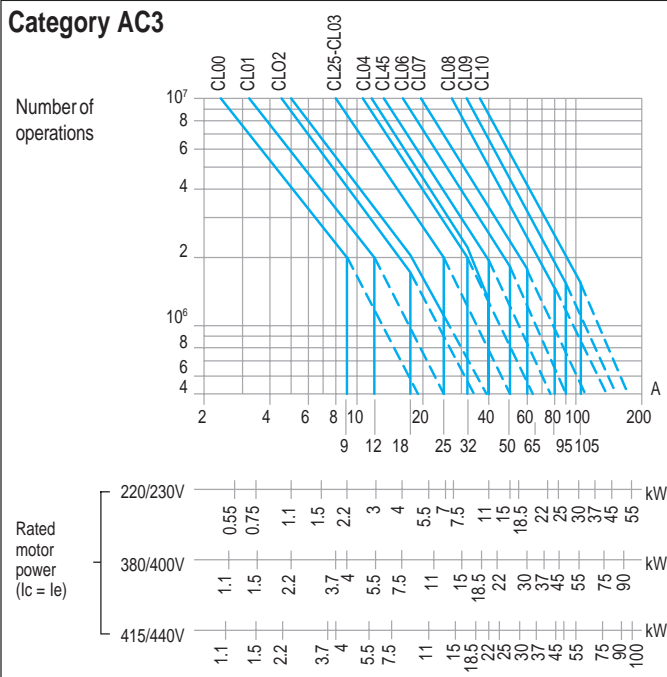

Category AC4

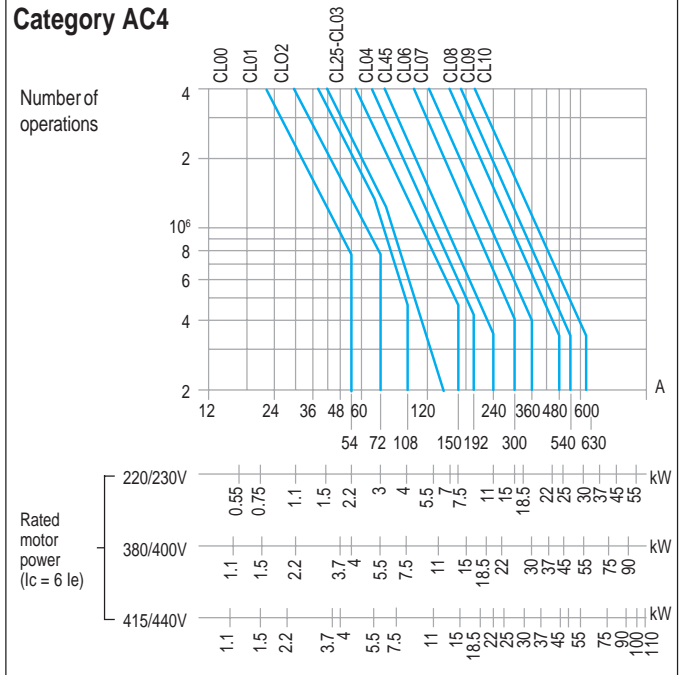

Mixed category AC4/AC3

Electrical endurance for mixed category (AC3/AC4) is calculated with the following formula :

$$\text{Electrical endurance (AC3/AC4)} = \frac{\text{Electrical endurance (AC3)}}{1 + \frac{\% \text{ oper. AC4}}{100} \times \left(\frac{\text{Elec. Endur. (AC3)}}{\text{Elec. Endur. (AC4)}} - 1 \right)}$$



Control circuit Three-pole and four-pole contactors

Alternating current		
Rated insulation voltage U_i (V)		1000
Standard voltages U_s 50 Hz (V)		24...690
Voltage operating limits monofrequency coils		
Operating	xUs	
Pick-up	xUs	
Seal	xUs	0.35...0.55
Consumption monofrequency coils		
Seal (VA)		6
Pick-up (VA)		
Thermal power dissipation (50 Hz/60 Hz)		(W)
Power factor		
Magnetic circuit closed (cos ϕ)		
Magnetic circuit open (cos ϕ)		
Opening and closing times		
Values between + 10 % U_s and - 20 % U_s		
Making time on excitation (NO contact) (ms)		
Breaking time on de-excitation (NO contact) (ms)		
Values at U_s		
Making time on excitation (NO contact) (ms)		
Breaking time on de-excitation (NO contact) (ms)		
Mechanical endurance		
Monofrequency coils		10^6 ops.
Bifrequency coils (at 50 Hz) 10^6 ops.		10
Maximum rate		
Monofrequency coils no load	ops./h	
AC1 at rated power	ops./h	
AC2 at rated power	ops./h	
AC3 at rated power	ops./h	
AC4 at rated power	ops./h	
Direct current		
Rated insulation voltage U_i (V)		1000
Standard voltages U_s (V)		
Operating limits		
Operating	xUs	
Pick-up	xUs	
Drop-out	xUs	
Consumption		
Magnetic circuit closed (W)		
Magnetic circuit open (W)		
Opening and closing times		
Values between + 10 % U_s and - 20 % U_s		
Making time on excitation (NO contact) (ms)		
Breaking time on de-excitation (NO contact) (ms)		
Values at U_s		
Making time on excitation (NO contact) (ms)		
Breaking time on de-excitation (NO contact) (ms)		
Mechanical endurance 10^6 ops.		
Maximum rate		
No load	ops./h	
AC1 and AC3 at rated power	ops./h	
AC4 at rated power	ops./h	

CL00...CL25	CL03...CL45	CL05...CL08	CL09...CL10
1000	1000	1000	
24...690	24...690	24...690	
0.8...1.1	0.8...1.1	0.8...1.1	0.8...1.1
0.6...0.8	0.65...0.8	0.65...0.8	0.65...0.8
0.4...0.6	0.4...0.6	0.4...0.6	
9	15.5	15.5	
45	88	191	191
2 / 1.7	2.8 / 3.3	4.5 / 3.9	4.5 / 3.9
0.39	0.31	0.35	0.35
0.82	0.76	0.64	0.64
6...20	7...25	9...35	9...35
6...13	5...25	9...15	9...15
8...20	10...19	15...30	15...30
6...13	5...25	9...15	9...15
15	15	15	15
10	8	8	
9000	9000	9000	5000
1200	1200	1200	1200
1000	1000	1000	750
1200	1200	1200	600
360	360	200	200
CL00D...CL25D	CL03D...CL45D	CL05E...CL08E	CL09E...CL10E
1000	1000	1000	
12...440	12...440	24...440	24...440
0.8...1.1	0.8...1.1	0.8...1.1	0.8...1.1
0.45...0.65	0.45...0.65	0.70...0.80	0.70...0.80
0.15...0.3	0.15...0.3	0.4...0.6	0.4...0.6
5.5	8	10	10
5.5	8	170	170
35...65	35...70	60...80	60...80
6...15	40...65	40...50	40...50
35...45	40...55	50...60	50...60
7...12	30...65	55...60	55...60
15	15	12	12
3600	3600	2500	2500
1200	1200	1200	600
360	360	200	200



Internal auxiliary contacts

Rated insulation voltage U_i according to IEC 947		(V)
Rated thermal current I_{th} at $\theta \leq 55^\circ\text{C}$		(A)
Making capacity (r.m.s.) according to IEC 947		
AC15/AC11 $U_e \leq 400\text{V}$, 50/60 Hz		(A)
DC13/DC11 $U_e \leq 220\text{V DC}$		(A)
Breaking capacity (r.m.s.) according to IEC 947		
AC15/AC11 $U_e \leq 400\text{V}$, 50/60 Hz		(A)
DC13/DC11 $U_e \leq 220\text{V DC}$		(A)
AC 15	Rated voltage and current U_e - I_e	according to IEC
		according to UL, CSA
DC 13	Rated voltage and current U_e - I_e	according to IEC
		according to UL, CSA
Electrical endurance		ops.
Minimum operational power (operational safety)		
Short-circuit protection	Max. fuse class gl-gG without welding	(A)
Insulation resistance	Between contacts	(M Ω)
	Between contacts and earth	(M Ω)
	Between input and output	(M Ω)
Guaranteed no overlap between NO and NC contacts		
	Space	(mm)
	Time	(ms)
Impedance of the contacts		(m Ω)

Auxiliary contact blocks

Rated insulation voltage (U_i) according to IEC 947		(V)
Rated thermal current I_{th} at $\theta \leq 55^\circ\text{C}$		(A)
Making capacity (I_{eff}) according to IEC		
AC15/AC11 $U_e \leq 400\text{V}$, 50/60 Hz		(A)
DC 13/DC11 $U_e \leq 220\text{V DC}$		(A)
Breaking capacity (I_{eff}) according to IEC 947		
AC15/AC11 $U_e \leq 400\text{V}$, 50/60 Hz		(A)
DC13/DC11 $U_e \leq 220\text{V DC}$		(A)
AC15	Rated voltage and current U_e - I_e	according to IEC
		according to UL, CSA
DC13	Rated voltage and current U_e - I_e	according to IEC
		according to UL, CSA
Electrical endurance		10^6 ops.
Mechanical endurance		10^6 ops.
Minimum operational current (operational safety)		
Short-circuit protection	Max. fuse class gl-gG without welding	(A)
Insulation resistance	Between contacts	(M Ω)
	Between contacts and earth	(M Ω)
	Between input and output	(M Ω)
Guaranteed no overlap between NO and NC contacts		
	Space	(mm)
	Time	(ms)
Impedance of the contacts		(m Ω)
Timing (ambient temperature between -25°C and $+55^\circ\text{C}$)		
	Accuracy	
	Loss of accuracy after 0.5×10^6 ops.	
	Loss of accuracy per rise $^\circ\text{C}$ ($0 - 55^\circ\text{C}$)	

CL00...CL02	CL03-CL04
1000	1000
20	20
250	250
250	250
250	250
2	2
110/120V-10A 220/230V-10A	110/120V-10A 230/220V-10A
400/380V-6A 415/450V-5A	400/380V-6A 415/450V-5A
500V-4A 690/660V-2A	500V-4A 690/660V-2A
A600	A600
24V-6A 48V-4A 110V-2A	24V-6A 48V-4A 110V-2A
220V-0.7A 440V-0.7A	220V-0.7A 440V-0.7A
P600	P600
10^6	10^6
17V - 5mA	17V - 5mA
10	10
> 10	> 10
> 10	> 10
> 10	> 10
1.3	2.6
1.5	1.5
1.28	1.28

Instantaneous blocks BCLF..., BCLL..., BRLL	Timed blocks BTLF...
1000	1000
10	10
90	90
90	90
60	60
0.95	0.95
120/110V-6A 230/220V-6A	120/110V-6A 230/220V-6A
400/380V-4A 440/415V-3.5A	400/380V-4A 440/415V-3.5A
500V-2.5A 690/660V-1.5A	500V-2.5A 690/660V-1.5A
A600	A600
24V-4A 48V-2A 110V-0.7A	24V-4A 48V-2A 110V-0.7A
220V-0.3A 440V-0.15A	220V-0.3A 440V-0.15A
Q600	Q600
1	1
10	5
17V - 5mA	17V - 5mA
10	10
> 10	> 10
> 10	> 10
> 10	> 10
1.3	1.3
1.5	5
1.28	1.28
-	$\pm 5\%$
-	+ 20%
-	+ 0.75% per $^\circ\text{C}$

Mechanical latch blocks

		RMLF ♦	
Rated insulation voltage U_i		1000 V	
Standard voltages U_s : 50 to 60 Hz and DC		24...690 V	
Operating limits		0.75...1.1 x U_s	
Consumption for unlatching (auto cut-out) 24 to 72 V 110 to 440 V		210 W / VA 130 W / VA	
Electrical unlatching control ⁽¹⁾ Minimum pulse Maintained		10 ms auto cut-out by integral contact	
Manual unlatching control		by local push-button	
Electrical making control Minimum pulse		40 ms auto cut-out by integral contact	
Manual making control		by local push-button	
Auxiliary contact NC Utilisation AC15/AC11		according to IEC	120V - 6A 500V - 1.5A 230V/220V - 4A 690V/660V - 1A 400V/380V - 2.5A
		according to UL/CSA	A600
Utilisation DC13/DC11		according to IEC	24V - 3A 220V - 0.3A 48V - 1.5A 400V - 0.15A 110V - 0.6A
		according to UL/CSA	Q600
Mechanical endurance CL00...CL45 CL05...CL10		3 million (1200 ops./h) 0.1 million (300 ops./h)	

Wiring diagram

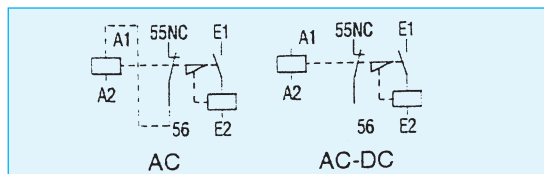

(1) The contactor coil and the unlatch control must not be energised simultaneously.

Terminal capacity for BCLF, BCLL, BTLF and RMLF

Solid	2 x 0.5 to 2.5 or 1 x 4
Stranded and finely stranded without end sleeve	2 x 0.5 to 2.5 or 1 x 4
Finely stranded with end sleeve	2 x 0.5 to 2.5 or 1 x 4
AWG wires, solid and stranded	12 - 22 AWG 75°C Wire
Tightening torque	1.1 Nm / 10 Lb x in.



Contact sequence (distance in mm)

□ Open

■ Closed

Basic contactor

Front mounted auxiliary contact blocks

BCLF 10



BCLF 01



Lateral mounted auxiliary contact blocks

BCLL 20
BRLL 20



BCLL 11
BRLL 11



Three-pole contactors 3NO

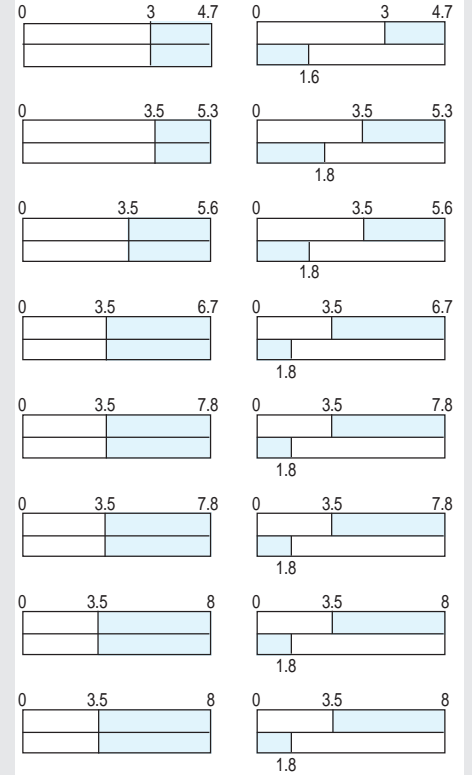
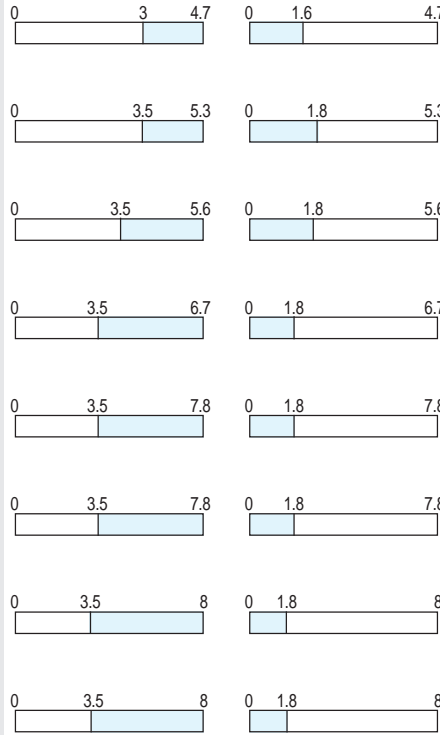
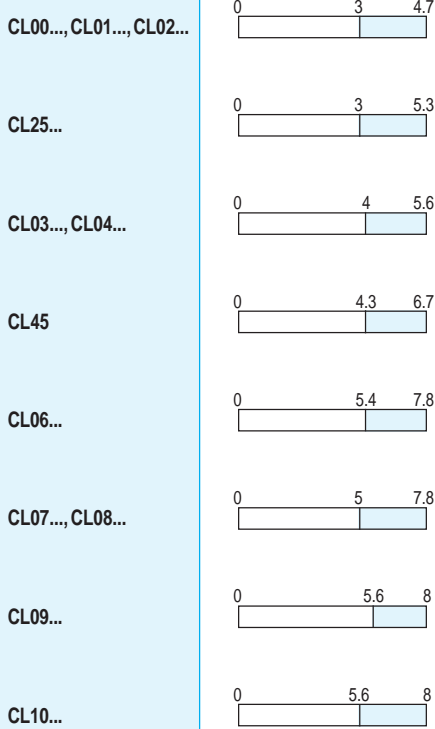

Four-pole contactors 4NO

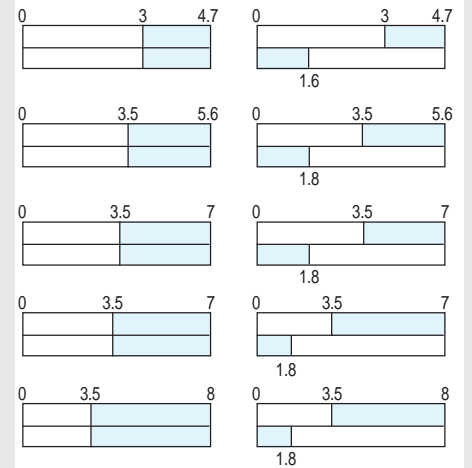
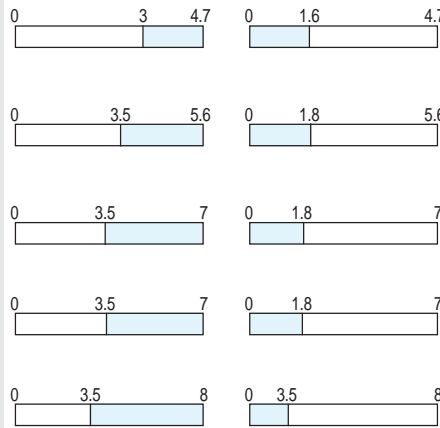
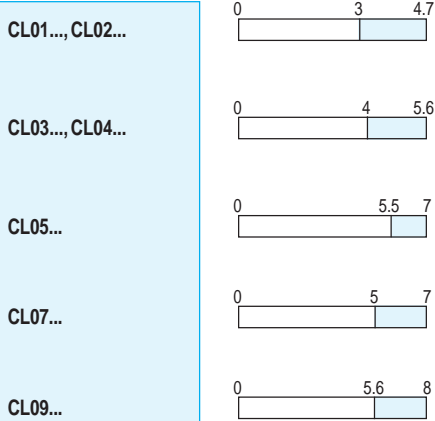

Four-pole contactors 2NO + 2NC

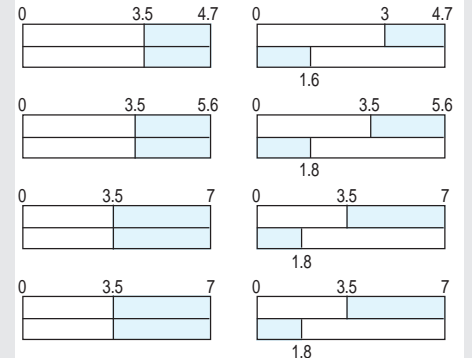
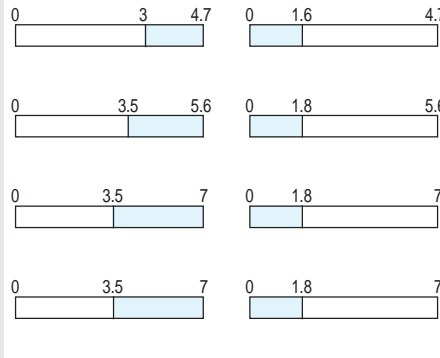
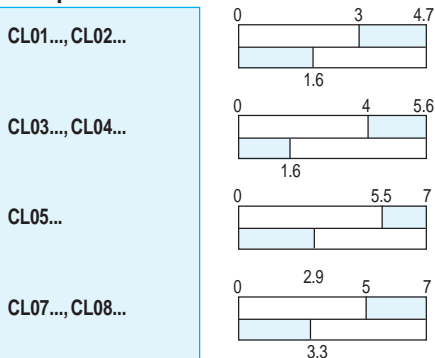



Terminal numbering according to EN 50012

	Combinations of auxiliary contacts		Final of the contactor	structure Possible basic contactors	Auxiliary contact blocks to be added
	Description	NO NC			
Without auxiliary contact blocks					
	10E	1 0		CL00 . 310T ♦ CL01 . 310T ♦ CL02 . 310T ♦	CL03 . 310M ♦ CL04 . 310M ♦
	01E	0 1		CL00 . 301T ♦ CL01 . 301T ♦ CL02 . 301T ♦	CL03 . 301M ♦ CL04 . 301M ♦
Front mounting auxiliary contact blocks with one contact each					
	11E	1 1		CL00 . 310T ♦ CL01 . 310T ♦ CL02 . 310T ♦	CL03 . 310M ♦ CL04 . 310M ♦ +BCLF01
	21E	2 1		CL00 . 310T ♦ CL01 . 310T ♦ CL02 . 310T ♦	CL03 . 310M ♦ CL04 . 310M ♦ +BCLF01 + BCLF10
	12E	1 2		CL00 . 310T ♦ CL01 . 310T ♦ CL02 . 310T ♦	CL03 . 310M ♦ CL04 . 310M ♦ +BCLF01 + BCLF01
	31E	3 1		CL00 . 310T ♦ CL01 . 310T ♦ CL02 . 310T ♦	CL03 . 310M ♦ CL04 . 310M ♦ +BCLF01 + BCLF10 +BCLF10
	41E	4 1		CL00 . 310T ♦ CL01 . 310T ♦ CL02 . 310T ♦	CL03 . 310M ♦ CL04 . 310M ♦ +BCLF01 + BCLF10 +BCLF10 + BCLF10
	22E	2 2		CL00 . 310T ♦ CL01 . 310T ♦ CL02 . 310T ♦	CL03 . 310M ♦ CL04 . 310M ♦ +BCLF01 + BCLF01 +BCLF10
	32E	3 2		CL00 . 310T ♦ CL01 . 310T ♦ CL02 . 310T ♦	CL03 . 310M ♦ CL04 . 310M ♦ +BCLF01 + BCLF01 +BCLF10 + BCLF10
	13E	1 3		CL00 . 310T ♦ CL01 . 310T ♦ CL02 . 310T ♦	CL03 . 310M ♦ CL04 . 310M ♦ +BCLF01 + BCLF01 +BCLF01
	23E	2 3		CL00 . 310T ♦ CL01 . 310T ♦ CL02 . 310T ♦	CL03 . 310M ♦ CL04 . 310M ♦ +BCLF01 + BCLF01 +BCLF01 + BCLF10
Lateral mounting auxiliary contact blocks with two contacts each					
	11E	1 1		CL00 . 300T ♦ CL01 . 300T ♦ CL02 . 300T ♦	CL25 . 300M ♦ CL04 . 300M ♦ CL45 . 300M ♦ +BCLL11
	31E	3 1		CL00 . 300T ♦ CL01 . 300T ♦ CL02 . 300T ♦	CL25 . 300M ♦ CL04 . 300M ♦ CL45 . 300M ♦ +BCLL11 + BCLL20
	22E	2 2		CL00 . 300T ♦ CL01 . 300T ♦ CL02 . 300T ♦	CL25 . 300M ♦ CL04 . 300M ♦ CL45 . 300M ♦ +BCLL11 + BCLL11

The maximum number of auxiliary contacts is four for CL00 to CL02 and six for CL03 and CL04. When using the pneumatic BTLF-block, these numbers are reduced to two, resp. four.



Terminal numbering according to EN 50012

		Combinations of auxiliary contacts		Final structure of the contactor	Possible basic contactors	Final structure of the contactor	Possible basic contactors	Auxiliary contact blocks to be added
		Description	NO					
Without auxiliary contact blocks								
					CL25 . 300T ♦ CL45 . 300T ♦		CL06 . 300M ♦ up to CL10 . 300M ♦	
Front mounting auxiliary contact blocks with one contact each								
		10E	1	0			CL25 . 300T ♦ CL45 . 300T ♦	CL06 . 300M ♦ up to CL10 . 300M ♦ + BCLF10
		01E	0	1			CL25 . 300T ♦ CL45 . 300T ♦	CL06 . 300M ♦ up to CL10 . 300M ♦ + BCLF01
		11E	1	1			CL25 . 300T ♦ CL45 . 300T ♦	CL06 . 300M ♦ up to CL10 . 300M ♦ + BCLF10 + BCLF01
		21E	2	1			CL25 . 300T ♦ CL45 . 300T ♦	CL06 . 300M ♦ up to CL10 . 300M ♦ + BCLF10 + BCLF01 + BCLF10
		12E	1	2			CL25 . 300T ♦ CL45 . 300T ♦	CL06 . 300M ♦ up to CL10 . 300M ♦ + BCLF10 + BCLF01 + BCLF01
		31E	3	1			BCLL11	CL06 . 300M ♦ up to CL10 . 300M ♦ + BCLF10 + BCLF01 + BCLF10 + BCLF10
		41E	4	1				CL06 . 300M ♦ up to CL10 . 300M ♦ + BCLF10 + BCLF01 + BCLF10 + BCLF10 + BCLF10
		22E	2	2			CL25 . 300T ♦ CL45 . 300T ♦	CL06 . 300M ♦ up to CL10 . 300M ♦ + BCLF10 + BCLF01 + BCLF01 + BCLF10
		32E	3	2				CL06 . 300M ♦ up to CL10 . 300M ♦ + BCLF10 + BCLF01 + BCLF01 + BCLF10 + BCLF10
		13E	1	3			CL25 . 300T ♦ CL45 . 300T ♦	CL06 . 300M ♦ up to CL10 . 300M ♦ + BCLF10 + BCLF01 + BCLF01 + BCLF10
		23E	2	3				CL06 . 300M ♦ up to CL10 . 300M ♦ + BCLF10 + BCLF01 + BCLF01 + BCLF10 + BCLF10
Lateral mounting auxiliary contact blocks with two contacts each								
		11E	1	1			CL25 . 300T ♦ CL45 . 300T ♦	CL06 . 300M ♦ up to CL10 . 300M ♦ + BCLL11
		31E	3	1			CL25 . 300T ♦ CL45 . 300T ♦	CL06 . 300M ♦ up to CL10 . 300M ♦ + BCLL11 + BCLL20
		22E	2	2			CL25 . 300T ♦ CL45 . 300T ♦	CL06 . 300M ♦ up to CL10 . 300M ♦ + BCLL11 + BCLL11

The maximum number of auxiliary contacts is eight ; with BTLF : maximum six.

Terminal numbering

Three-pole and four-pole contactors

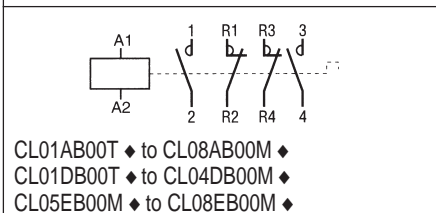
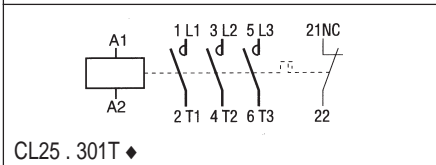
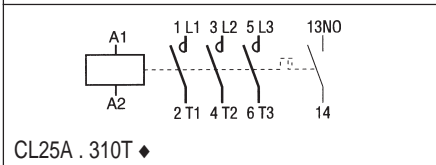
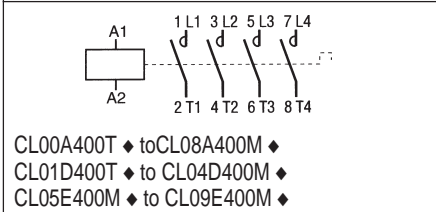
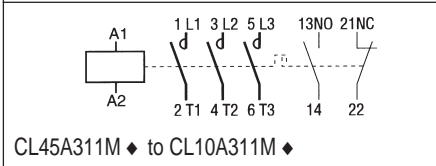
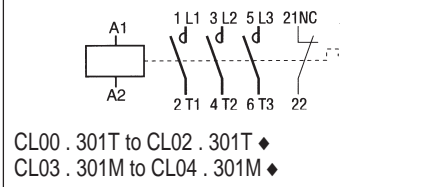
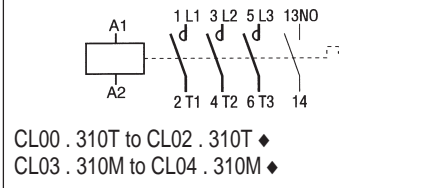
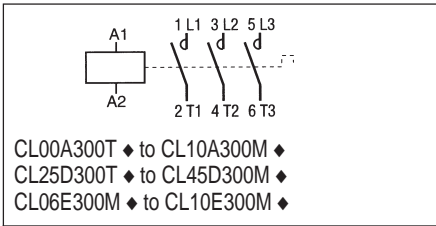

Auxiliary contact blocks Front mounting

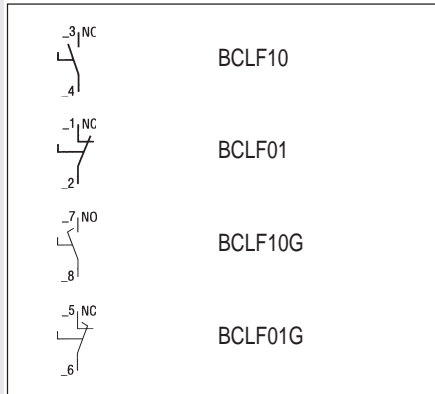

Pneumatic timer blocks

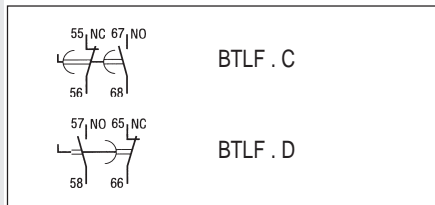

Electronic timer blocks

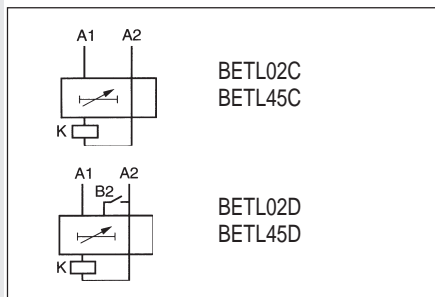

Voltage suppressor blocks

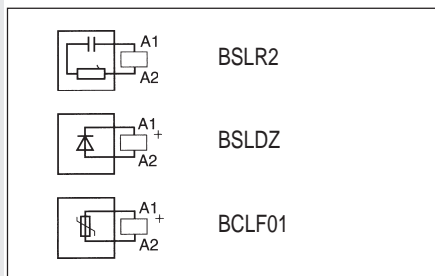

Voltage suppressor blocks for utilisation with interface modules and electronic timers

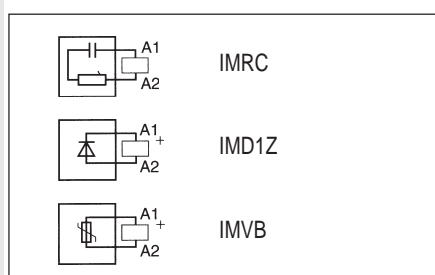

Auxiliary contact blocks Lateral mounting

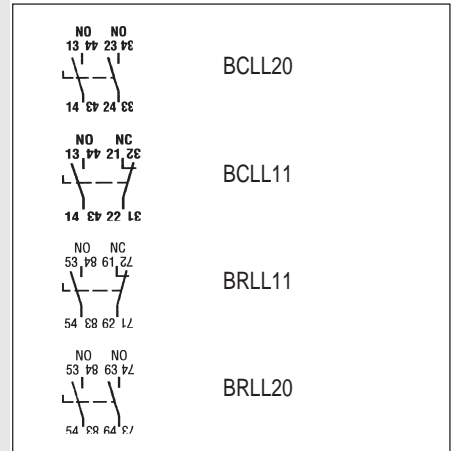

Mechanical latch block

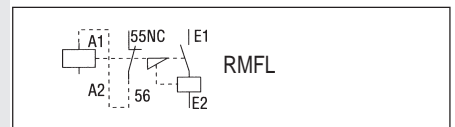

Mechanical interlock

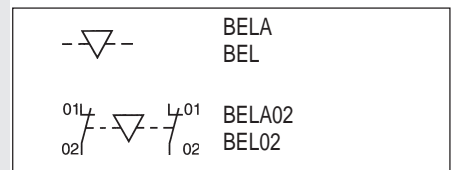

Interface module

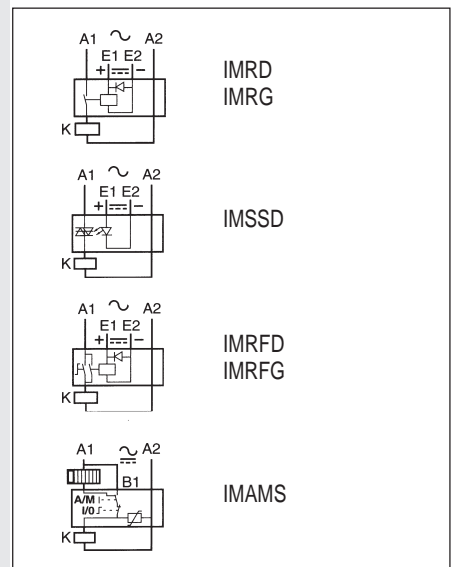



Three-pole and four-pole AC contactors

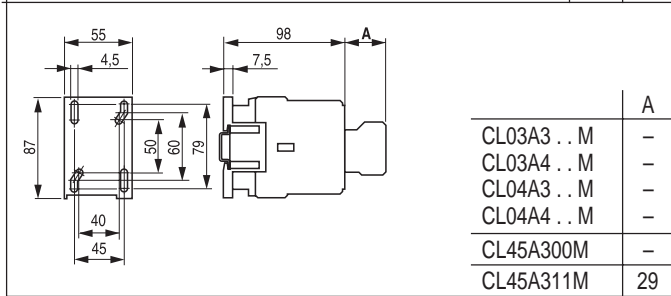
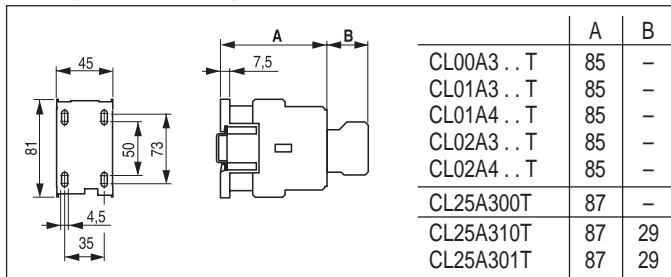

Three-pole and four-pole DC contactors

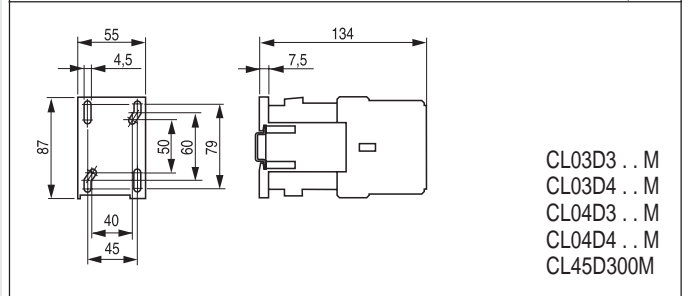
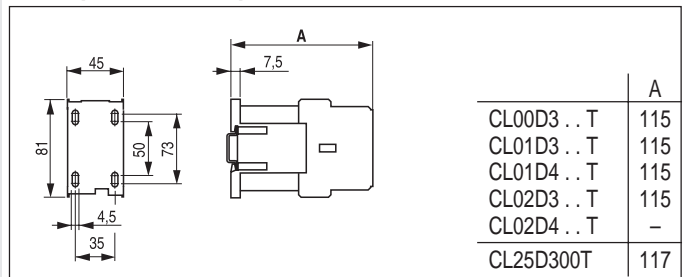

Three-pole AC contactors

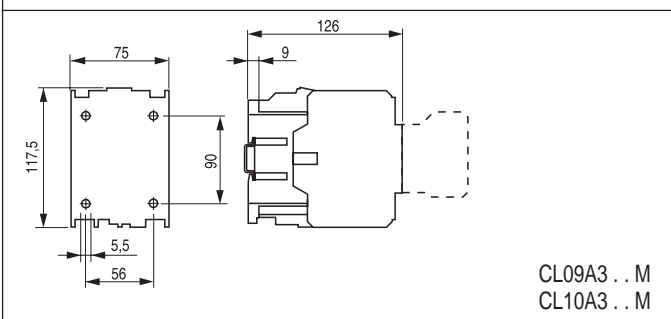
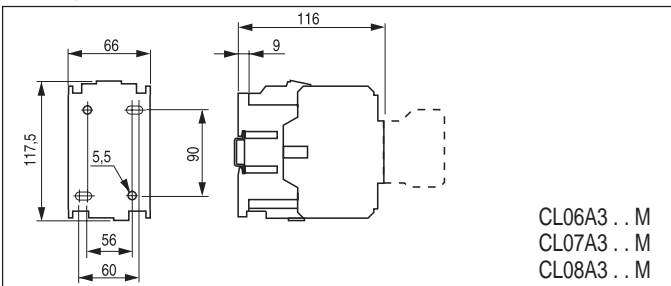

Three-pole DC contactors

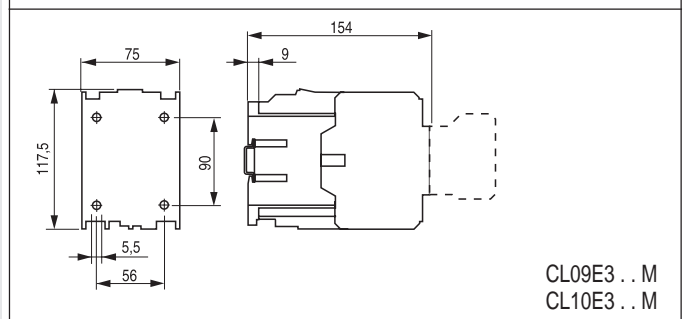
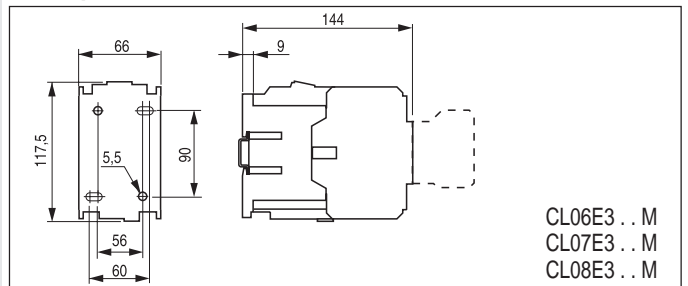

Four-pole AC contactors

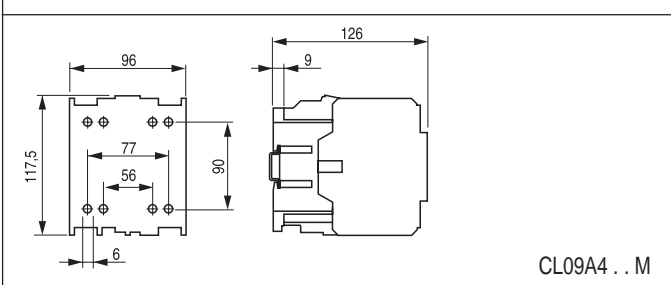
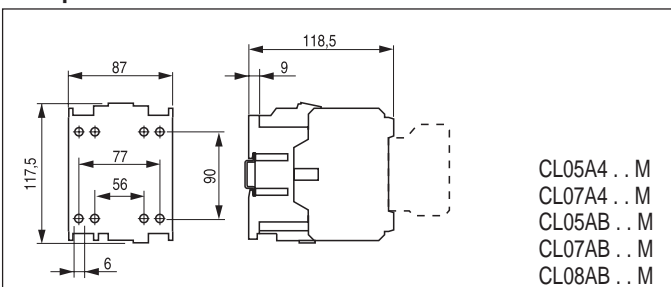

Four-pole DC contactors

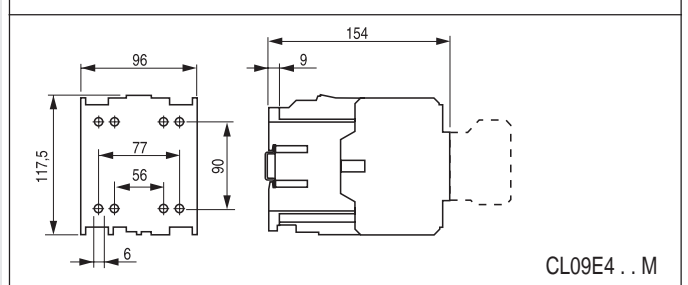
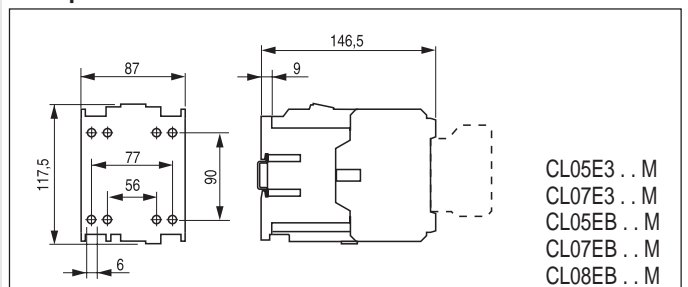

Front mounting auxiliary contact blocks

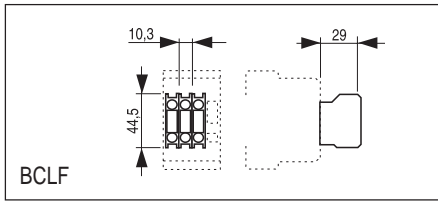

Lateral mounting auxiliary contact blocks

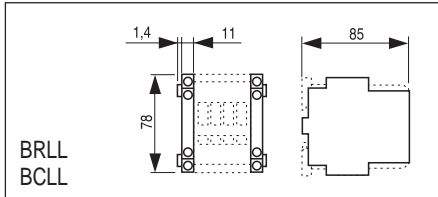

Pneumatic timer block

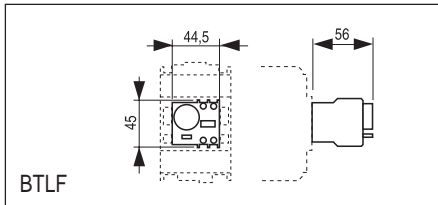

Mechanical latch block

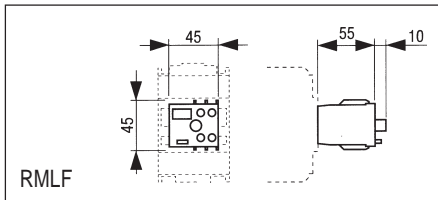

Mechanical / mechanical-electrical interlock

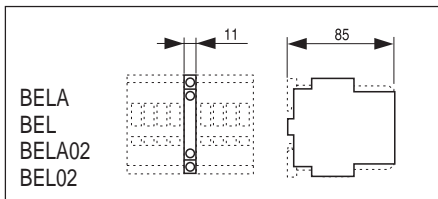

Electronic timer block

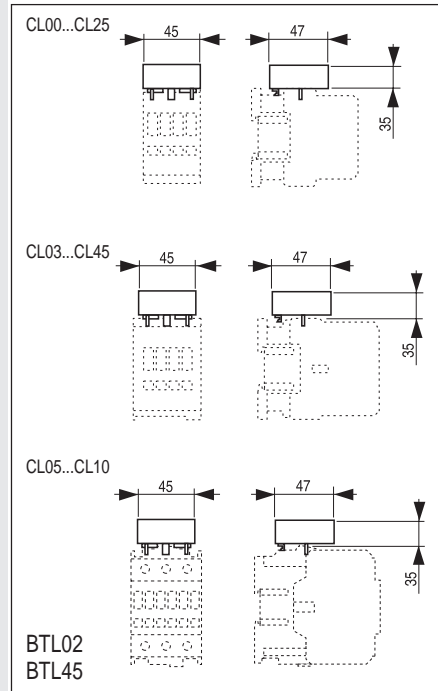

Interface modules

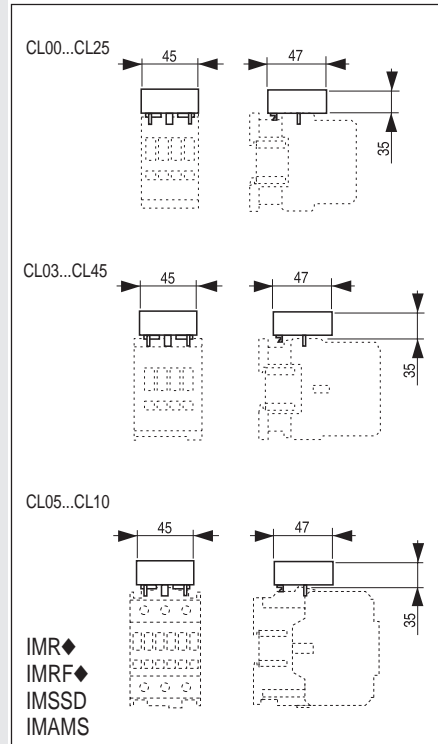

Voltage suppressor block

