

# Siemens Simodrive 611

<i>Part #</i>	<i>Part #</i>
6SN1124-1AA00-0AA1	6SN11241AA000AA1
6SN1124-1AA00-0BA1	6SN11241AA000BA1
6SN1124-1AA00-0DA1	6SN11241AA000DA1
6SN1124-1AA00-0EA1	6SN11241AA000EA1
6SN1124-1AA00-0LA1	6SN11241AA000LA1
6SN1124-1AA01-0FA1	6SN11241AA010FA1
6SN1124-1AB00-0AA1	6SN11241AB000AA1



*Presented by – MROELECTRIC.COM*

*Quote Email: [inquiry@MROELECTRIC.COM](mailto:inquiry@MROELECTRIC.COM)*

*Call: **1-800-466-0649***

*Fax: **919-415-1614***

*<http://www.MROELECTRIC.COM/>*

# SIMODRIVE 611 XJ[ ]H

Drive Converter

Configuration Manual · 02/2012

SIMODRIVE

**SIEMENS**



## SIMODRIVE 611 digital

### Drive Converters

#### Configuration Manual

Valid for

*Equipment series 6SN11–*

#### Preface, Table of Contents

Overview of the Drive System	<b>1</b>
System Configuration	<b>2</b>
Motor Selection and Position/Speed Sensing	<b>3</b>
Control Units	<b>4</b>
Power Modules	<b>5</b>
Infeed Modules	<b>6</b>
Line Supply Connection	<b>7</b>
Important Circuit Information	<b>8</b>
Cabinet Design and EMC	<b>9</b>
Connection Diagrams	<b>10</b>
Service and Spare Parts	<b>11</b>
Dimension Drawings	<b>12</b>
Abbreviations and Terminology	<b>A</b>
References	<b>B</b>
Certificates/ Declarations of Conformity	<b>C</b>
Index	<b>D</b>

## SIMODRIVE® documentation

### Printing history

Brief details of this edition and previous editions are listed below.  
The current configuring manual replaces the previous version.

The status of each edition is shown by the code in the "Remarks" column.

*Status code in the "Remarks" column:*

**A...** New documentation

**B...** Unrevised reprint with new Order No.

**C...** Revised edition with new status

If technical changes have been made on the page since the last edition, this is indicated by a new edition coding in the header on that page.

<b>Edition</b>	<b>Order No.</b>	<b>Remarks</b>
04.93	6SN1060-0AA01-0BA0	<b>A</b>
08.93	6SN1197-0AA00-0BP0	<b>C</b>
12.94	6SN1197-0AA00-0BP1	<b>C</b>
11.95	6SN1197-0AA00-0BP2	<b>C</b>
02.98	6SN1197-0AA00-0BP3	<b>C</b>
08.98	6SN1197-0AA00-0BP4	<b>C</b>
05.01	6SN1197-0AA00-0BP5	<b>C</b>
02.03	6SN1197-0AA00-0BP6	<b>C</b>
10.04	6SN1197-0AA00-0BP7	<b>C</b>
11.05	6SN1197-0AA00-0BP8	<b>C</b>
02.07	6SN1197-0AA00-1BP0	<b>C</b>
05.08	6SN1197-0AA00-1BP1	<b>C</b>
02.12	6SN1197-0AA00-1BP2	<b>C</b>

### Trademarks

All products mentioned may be trademarks or product designations of Siemens AG or their suppliers, whose use by third parties for their own purposes may infringe the rights of the trademark owners.

We have checked that the contents of this publication agree with the hardware and software described here. Nevertheless, differences might exist and therefore we cannot guarantee that they are completely identical. The information in this document is regularly checked and necessary corrections are included in reprints. Suggestions for improvement are also welcome.

# Foreword



---

## Reader's note

The Configuration Manual describes a reference state, which when observed, ensures the required reliable operation and compliance with the standards that have been taken into account.

For deviations from the requirements laid down in the Configuration Manual, suitable measures must be applied, for example, measurements, securing or verifying that the required reliable operation is guaranteed and that the standards to be taken into account are complied with from a regulatory perspective.

The documentation must be completely read, understood and taken into account before the devices are commissioned.

If parts of the documentation have not been adequately understood, then please contact your local Siemens person before you continue to work with the devices.

The contents of this document are neither part of an earlier or existing agreement, commitment or contractual relationship, nor do they change this. Siemens is obliged to fulfill all requirements specified in the applicable sales contract, which also contains all the valid terms of warranty.

Any statements contained herein neither create new warranties nor modify the existing warranty.

---

## Structure of the documentation

The SIMODRIVE documentation is subdivided into the following levels:

- General Documentation/Catalogs
- User Documentation
- Manufacturer/Service Documentation

## Additional information

You can find information on the following topics under the following link:

- Ordering documentation/overview of documents
- Links to download documents
- Using documentation online (searching and scanning through manuals/information)

<http://www.siemens.com/motioncontrol/docu>

If you have any questions regarding the technical documentation (e.g., suggestions, corrections), then please send an e-mail to the following address

[docu.motioncontrol@siemens.com](mailto:docu.motioncontrol@siemens.com)

## My Documentation Manager

Information is provided under the following link as to how you can individually compile documentation based on Siemens content, and adapt this for your own machine documentation:

<http://www.siemens.com/mdm>

## Training

Information about SITRAIN – Siemens training courses for products, systems and solutions in automation technology – is provided under the following link:

<http://www.siemens.com/sitrain>

---

## 1.2 Systemkonfiguration 1

- FAQs** You can find Frequently Asked Questions in the Service&Support pages under Product Support:  
<http://support.automation.siemens.com>
- Target group** This documentation addresses machine manufacturing companies (OEMs) that wish to configure, construct and commission a drive line-up based on SIMODRIVE components.
- Technical Support** Local country telephone numbers for technical support are provided in the Internet under Contact:  
<http://www.siemens.com/automation/service&support>
- Certificates** You will find the certificates for the products described in this documentation in the Internet: <http://www.support.automation.siemens.com> under the Product/Order No. 15257461 or contact the relevant branch office of the A&D MC group of Siemens AG. All declarations of conformity and certificates such as CE, UL, etc., are performed with the system components described in the associated Configuration Manuals or catalogs and, thus, are only valid if the described components are used in the device or facility.

---

**Note**

The use of components not released by Siemens may require the user to prepare new certificates/declarations of conformity.

---

## Repairs

---

### Note

Repairs may be performed only by workshops authorized by Siemens who must use genuine spare parts. Unauthorized repairs and the use of other spare parts can result in personal injuries and property damage as well as loss of UL approvals and safety functions, such as Safety Integrated.

---



---

### Warning

SIMODRIVE converters are used in high voltage installations and are operated at voltages that when touched can cause serious injuries or death!

---

## Proper use

Note the following:

---



---

### Warning

Siemens products may only be used for the intended use in applications described in the catalog and the associated technical documentation. If third-party products and components are used, then these must either be recommended or certified by Siemens. The perfect and safe operation of products assumes that they have been correctly transported, correctly stored, located, mounted, installed, commissioned, operated and maintained. The permissible environmental conditions must be complied with.

Information and instructions in the associated documentation must be observed.

---

## Definition: Who are qualified personnel?

Setup and operation of the device/equipment/system in question must only be performed using this documentation. Commissioning and operation of a device/system may only be performed by **qualified personnel**. Qualified personnel as referred to in the safety instructions in this documentation are persons authorized to start up, ground, and label devices, systems, and circuits in accordance with the relevant safety standards.

## Objectives

This Configuration Manual provides all of the detailed information required to use and handle SIMODRIVE components.

Should you wish for additional information or should exceptional problems arise that are not addressed in sufficient detail in this manual, you can request the required information from your local Siemens office.

The Configuration Manual describes a modular drive system. It is permissible to use the constellations and general versions described here. All other combinations must be separately and individually released by Siemens.



**Information for using this Manual**

The following should be observed when using this manual:

1. Help: The following help is available for the reader:
  - Complete table of contents
  - Header line (as orientation):  
the main chapter is in the upper header line  
the sub–chapter is in the lower header line
  - Appendix with
    - Abbreviations and List of References
    - Index
 If you require information regarding a specific term, then look for this in the Appendix under the Chapter "Index".  
The Chapter number as well as the page number is specified where information on this term can be found.
2. Edition of the documentation:  
The history of the document editions is summarized in the printing history.  
The header of the document indicates the current edition (12/2006).



**Reader's note**

Only the digital components for a SIMODRIVE group with High Performance/ High Standard and 611 universal modules are described in Edition A10.04 and higher. Please refer to the overview in Chapter 4.1 regarding from which software releases, use is possible.

The descriptions for the relevant controls in the Configuration Manual, Edition 02.03, still remain valid for the analog components that have been discontinued (not for new configurations)!

**Safety information**

This documentation contains information that must be observed to ensure your personal safety and to prevent material damage. The instructions for your personal safety are marked by a warning triangle. Instructions relating solely to material damage are not marked by a warning triangle. The warnings appear in decreasing order of risk as given below.



**Danger**

indicates that death or serious injury **will** result if proper precautions are not taken.



**Warning**

indicates that death or serious injury **may** result if proper precautions are not taken.



---

**Caution**

with a safety alert signal indicates that minor personal injury **can** result if proper precautions are not taken.

---



---

**Caution**

without a safety alert symbol, indicates that property damage **can** result if proper precautions are not taken.

---



---

**Notice**

indicates that an undesirable result or state **may** arise if the relevant note is not observed.

---

**Additional information**

---

**Note**

This symbol indicates important information about the product or part of the document, where the reader should take special note.

---



---

**Reader's note**

This symbol is shown, if it relates to important information which the reader must observe.

---

**Technical information**

---

**Warning: High leakage current**

As a result of the high switching frequencies, capacitances (parasitic and integrated) with respect to ground may cause high leakage currents. This is the reason that a permanent PE connection is required at the control cabinet and at the line filter!

Measures according to EN 50178/94 Part 5.3.2.1 must be implemented, e.g.

1. Copper protective conductor with a minimum cross-section of 10 mm<sup>2</sup> should be connected, or
2. A second conductor should be connected in parallel with the protective conductor through separate terminals.

This conductor must also fully meet the requirements for PE conductors according to IEC 364-5-543.

---

---

**Note**

The SIMODRIVE 611 drive converter system can be directly connected to TN line supplies with rated voltages 3-ph. 380 V AC (with derating), 3-ph. 400 V AC, 3-ph. 415 V AC and 3-ph. 480 V AC. Matching transformers, which are tailored to the system, are available to connect the system to other line supply types, for example, to IT or TT line supplies.

Upstream devices providing protection against hazardous leakage currents or for fire protection (such as residual-current protective devices) must be AC/DC-sensitive in accordance with the requirements of DIN EN 50178. In the case of other residual current protective devices, a transformer with separate windings must be connected upstream of the converter for purposes of decoupling. See Chapter 7.

---



---

**Warning**

When electrical equipment is operated, certain parts of this equipment are inevitably under dangerous voltage.

Incorrect handling of these units, i.e. not observing the warning information, can therefore lead to death, severe bodily injury or significant material damage.

Only appropriately qualified personnel may commission/start up this equipment.

These personnel must be thoroughly familiar with all warnings and maintenance procedures described in these operating instructions.

Perfect, safe and reliable operation of the equipment assumes that it has been appropriately transported and repaired and professionally stored, mounted and installed as well as carefully operated and serviced. Failure to observe these requirements can endanger the user (electrical shock, fire hazard) or damage the device.

Hazardous axis motion can occur when working with the equipment.

Further, all of the relevant national, local land plant/system-specific regulations and specifications must be taken into account.

---



---

**Caution**

The DC link discharge voltage hazard warning in the local language must be clearly attached to the appropriate modules.

---



---

**Note**

When handling cables, please observe the following:

- are not damaged
  - they may not be stressed,
  - they may not come into contact with rotating components.
-

---

**Notice**

M600 and M500 are not PE voltages. Hazardous voltages of between 300 ... 400 V with respect to PE are present at the terminals. These potentials (voltages) may not be connected to PE.

---

**Note**

The machine builder must ensure that the voltage drop between the start of the consumer's installation and the power drive system (PDS) does not exceed 4% when operating with rated values.

---

**Warning**

The "protective separation" can only be guaranteed when using the components permitted/certified by Siemens for the system.

"Protective separation" can only be guaranteed when it is absolutely certain that the system components have the appropriate degree of protection.

To ensure "protective separation", the shield of the brake cable must be connected to PE through the largest possible surface area.

"Protective separation" is required between the temperature sensor and motor winding.

If these limitations and constraints are not carefully observed then this can result in injury due to electric shock.

---

**Warning**

Start-up/commissioning is absolutely prohibited until it has been ensured that the machine in which the components described here are to be installed, fulfills the regulations/specifications of the Directive 89/392/EEC. If this is not observed, this can result in injury.

---

**Warning**

The information and instructions in all of the documentation supplied and any other instructions must always be observed to eliminate hazardous situations and damage.

- For special versions of the machines and equipment, the information in the associated catalogs and quotations applies.
- Further, all of the relevant national, local and plant/system-specific regulations and specifications must be taken into account.
- All work should be undertaken with the system in a no-voltage condition!

If this is not observed, this can result in injury.

---



---

**Warning**

Even after the disconnection of all power, a dangerous residual voltage as high as 60 V DC can still be present. For capacitor modules, this hazardous voltage can be present for up to 30 min.

In order to ensure that no hazardous voltages are present, the voltage must be first carefully measured (generator principle when motors are rotating). If this is not observed, then this can result in injury due to electric shock.

For this reason, opening the device or removing the cover is permitted only after up to 30 minutes have elapsed (depending on the degree of expansion) since the device was switched to the voltage-free state. All covers must be reattached before the line voltage is switched on. Operation of the plant with damaged DC link covers is not permitted!

**Danger of death!**

Touching live terminals, cables or device parts can result in serious injury or death!

---



---

**Warning**

Do not switch off devices, e.g. using a line supply isolating device (main switch), before disabling the pulse inhibit (T 48) on the infeed/regenerative feedback modules. Otherwise, the device can be destroyed along with other devices in the control cabinet.

---



---

**Warning**

The rated current of the connected motor must match the rated converter current. If this is not the case, then the protection of the motor cables is no longer guaranteed. The cross-section of the motor feeder cable must be dimensioned for the rated drive converter current. If this is not carefully observed, cables can overheat and can even cause an equipment fire.

---

---

**Caution**

When using mobile radios (e.g. cellular phones, mobile phones, 2-way radios) with a transmission power of > 1 W close to the equipment (< 1.5 m) the function of the equipment can be disturbed.

---

---

**Note**

This device/module is an open-type device corresponding to UK 50 and, thus, may only be operated in enclosures/cabinets that ensure protection against mechanical damage. To ensure protection against mechanical damage, the devices may only be operated in enclosures/cabinets with degree of protection IP54 in accordance with EN 60529.

---

---

**Note**

The terminal blocks of the SIMODRIVE 611 modules are used for electrical connection of the particular module. If the terminal blocks are used for another purpose (e.g. to carry the module), this can damage the module. If the insulation is damaged, then this can cause injury due to electric shock.

---

---

**Note**

For a minimum fault current, the machine manufacturer must ensure that the upstream overcurrent protection devices trip within 5 s (see Chapter 7.3; Table 7-5 and Fig. 7-8)

---

---

**Note**

The following secondary conditions/limitations must be carefully observed if the machine is subject to a high-voltage test:

1. Power-down the unit.
  2. Withdraw the overvoltage module in order to prevent the voltage limiting responding.
  3. Disconnect the line filter so that the test voltage does not dip.
  4. Connect M600 to PE through resistor 100 k $\Omega$  (the grounding clip in the NE modules is open). In the factory, the units are subject to a high-voltage test at 2.25 kV<sub>DC</sub> phase-PE. The NE modules are shipped with the grounding clip open.
  5. The maximum permissible voltage for a high-voltage machine test is 1.kV<sub>DC</sub> phase-PE.
- 



---

**Danger**

The control and drive components for a power drive system (PDS) are allowed for industrial and commercial use in industrial networks. Their use in public networks requires a different configuration and/or additional measures.

---

**ESDS information and instructions**



**ElectroStatic Discharge Sensitive Devices**

Components, which can be destroyed by electrostatic discharge are individual components, integrated circuits, or boards, which when handled, tested, or transported, could be destroyed by electrostatic fields or electrostatic discharge. These components are referred to as **ESDS (ElectroStatic Discharge Sensitive Devices)**.

Handling ESDS modules:

- When handling devices which can be damaged by electrostatic discharge, personnel, workstations and packaging must be well grounded!
- Generally, electronic modules may not be touched unless work has to be carried out on them.
- Personnel may only touch components if
  - they are continuously grounded through ESDS wristlets,
  - they wear ESDS shoes, ESDS shoe grounding strips in conjunction with an ESDS floor surface.
- Boards/modules must only be placed on conductive surfaces (table with ESDS surface, conductive ESDS foam, ESDS packaging, ESDS transport container).
- Modules may not be brought close to data terminals, monitors or television sets (minimum clearance to the screen > 10 cm).
- Do not bring ESDS-sensitive modules into contact with chargeable and highly-insulating materials, such as plastic sheets, insulating table tops or clothing made of synthetic materials.
- Measuring work may only be carried out on the components if
  - the measuring unit is grounded (e.g. via a protective conductor) or
  - when floating measuring equipment is used, the probe is briefly discharged before making measurements (e.g. a bare-metal control housing is touched).



**Warning**

If static discharge occurs on surfaces or interfaces that cannot be easily accessed, malfunctions and/or defects will result.



**Warning**

When the system boots, this represents a critical operating state with increased risk. In this phase, especially when activating drives, it is not permissible that personnel are close to the hazardous area.



**Warning**

After hardware and/or software components have been modified or replaced, it is only permissible that the system runs-up and the drives are activated with the protective devices closed (could possibly result in death). Personnel shall not be present within the danger zone.

It may be necessary to carry-out a new, partial or complete acceptance test after every change or replacement.

Before entering the hazardous area, it should be carefully checked that all of the drives exhibit stable behavior by briefly moving the drives in both directions (+/-).



---

**Warning**

If the "safe standstill" function or a stop function, Category 0 in accordance with EN 60204–1, is activated, the motor can no longer provide any torque. As a result of this, potentially hazardous motion can occur, e.g. for:

- When the drive axes are subject to an external force.
- Vertical and inclined axes without weight equalization.
- Axes that are moving (coasting down).
- Direct drives with low friction and self–locking behavior.

Possible hazards must be clearly identified using a risk analysis that must be carried out by the manufacturer. Using the assessment based on this risk analysis, it must be defined as to which additional measures are required (e.g. external brakes).

---



---

**Warning**

If the "safe standstill" function is activated, when a fault condition occurs, the mechanical axis system can make a jerky movement (possibility of injury, crushing) as a result of the principle of operation. The magnitude of this movement depends on the following parameters:

- Design/configuration and mechanical ratios between the motor/mechanical system.
  - Speed and acceleration capability of the motor
  - Magnitude of the selected monitoring clock cycle.
  - Size of the selected standstill tolerance window.
- 

The danger and warning information above must always be unconditionally observed in order to avoid personal injury and property damage.



**Health and safety  
in the workplace**

The professional associations for precision and electrical engineering specify limits for electrical load in the workplace. Compliance with Federal Emission Control Law is mandatory in the Federal Republic of Germany!

Adherence to the RFI suppression limits for EMC does not also ensure adherence to the requirements for workplaces.

In particular, machine construction, control cabinet structure, shop environment, infeed conditions and other installations have a substantial impact on adherence to the limits required by the trade association for the respective workplace.

Therefore, the operator must always clarify whether wearers of pacemakers may be employed at the planned workplace without endangering their health.

## Residual risks

When carrying out a risk assessment of the machine in accordance with the EU Machinery Directive, the machine manufacturer must consider the following residual risks associated with the control and drive components of a power drive system (PDS).

1. Unintentional movements of driven machine components during commissioning, operation, maintenance, and repairs caused by, for example:
  - Hardware defects and/or software errors in the sensors, controllers, actuators, and connection technology
  - Response times of the controller and drive
  - Operation outside the specification
  - Errors when parameterizing, programming and wiring
  - Use of radio devices/cellular phones in the immediate vicinity of the controller
  - External effects
2. Exceptional temperatures as well as emissions of light, noise, particles, or gas caused by, for example:
  - Component malfunctions
  - Software errors
  - Operation outside the specification
  - External effects
3. Hazardous shock voltages caused by, for example:
  - Component malfunctions
  - Static charges
  - Operation outside the specification
  - Condensation/conductive contamination
  - External effects
4. Electrical, magnetic, and electromagnetic fields that can pose a risk to people with a pacemaker and/or implants if they are too close.
5. Emission of pollutants if components or packaging are not disposed of properly.

An assessment of the residual risks (see points 1 to 5 above) established that these risks do not exceed the specified limit values (risk priority number in accordance with EN 60812 RPZ = 100). For additional information, refer to the relevant sections of the Configuration Manual.

At the present time, other known residual risks are:

- Acceleration of the spindle or axes due to:
  - Encoder errors, e.g. errors in the absolute measuring system (CD track), loose contacts in encoder cables or unsuitable encoders.
  - Cyclically interchanged phases of the motor connections (V–W–U instead of U–V–W).
  - Interchanged control sense.
  - Electric faults (defective components, etc.).
  - Operation of a demagnetized synchronous motor with saturation-based pole position identification.
  - Transfer of an incorrect, but plausible actual value in absolute measuring systems (encoder does not signal an error).

- If two power transitions in the inverter are simultaneously destroyed, depending on the motor pole number, this can cause brief axis movement.
  - Example: Synchronous motor:

For a 6-pole synchronous motor, the maximum mechanical motion on the motor shaft can be 30 degrees.  
With a ballscrew that is directly driven (e.g. 10 mm per revolution) this corresponds to a maximum linear motion of approximately 0.8 mm.
  - Example, synchronous linear motor:

For a synchronous linear motor, the movement can be a maximum of one pole width, refer to the Motors Configuration Manual.
- For a 1-encoder system, encoder faults are detected by various HW and SW monitoring functions. It is not permissible that these monitoring functions are deactivated and they must be parameterized carefully.
- Stop function Category 0 according to EN 60204-1 means that the spindle/axes are not braked. Depending on the kinetic energy involved, they can coast-down for a long time.

This must be integrated in the logic of the protective door interlocking (e.g. with a logic operation with the signal  $n < nx$ ).
- Violation of limits may briefly lead to a speed higher than the speed setpoint, or the axis may pass the defined position to a certain extent, depending on the dynamic response of the drive and on parameter settings (MD).
- Parameterization and programming errors made by the machinery construction OEM cannot be identified. The required level of safety can only be assured by a thorough and careful acceptance testing.
- When replacing power modules or motors, the same type must always be used as otherwise the selected parameters may result in different responses.

When an encoder is replaced, the axis involved must be re-calibrated.
- If the line infeed units are connected to the line supply, where the minimum short-circuit current is not reached, then the overcurrent protection devices will not be able to trip within the appropriate time. There is a risk of fire in the case of a fault!



# Contents

<b>1</b>	<b>Overview of the Drive System</b>	<b>1-25</b>
1.1	Overview of SIMODRIVE 611	1-25
1.2	Engineering steps	1-29
1.3	Engineering a drive	1-31
1.3.1	Calculation of the required DC link power (PZK) for dimensioning the supply system, infeed unit	1-33
1.3.2	Dynamic operation	1-34
1.3.3	Braking operation	1-35
1.3.4	Calculation of the DC link power (engineering sheet)	1-36
1.3.5	Checking the permissible power supply rating	1-37
<b>2</b>	<b>System Configuration</b>	<b>2-41</b>
2.1	Arrangement of the modules and their mounting	2-42
2.1.1	Arrangement of the modules	2-42
2.1.2	Mounting and installing the modules	2-45
2.2	Ambient conditions	2-46
2.3	Motor selection	2-48
2.4	Position sensing/actual speed value sensing	2-49
2.4.1	Position sensing, direct	2-49
2.4.2	Position detection, indirect	2-50
2.4.3	Drive module	2-51
2.5	Power modules	2-51
2.5.1	Function of the power modules	2-52
2.5.2	Connecting-up the power modules	2-52
2.6	Control units	2-53
2.6.1	General	2-53
2.6.2	AC motors	2-53
2.6.3	Modules included in the scope of supply	2-53
2.6.4	NCU box for SINUMERIK 840D	2-54
2.7	Infeed modules	2-55
2.7.1	Cooling components	2-57
2.7.2	Internal cooling	2-59
2.7.3	External cooling	2-60
<b>3</b>	<b>Motor Selection, Position/Speed Sensing</b>	<b>3-63</b>
3.1	Motor selection	3-63
3.1.1	Motor protection	3-63
3.1.2	Motors with holding brake	3-63
3.2	Motor encoder	3-64
3.3	Indirect position and motor speed sensing	3-68

3.4	Direct position sensing .....	3-68
3.4.1	Encoder systems that can be evaluated .....	3-68
3.4.2	Encoder power supply .....	3-72
3.4.3	Encoder power supply for SSI encoders .....	3-74
3.4.4	Signal amplifier electronics .....	3-76
3.5	Overview, position sensing .....	3-78
3.6	Ordering information .....	3-80
<b>4</b>	<b>Control Units .....</b>	<b>4-81</b>
4.1	Closed-loop control with digital setpoint interface .....	4-83
4.1.1	Interface overview, closed-loop drive control .....	4-87
4.2	"SIMODRIVE 611 universal HRS" control board .....	4-91
4.2.1	Control board for 1 or 2 axes .....	4-93
4.2.2	Description of the terminals and interfaces .....	4-98
4.3	"HLA module" control board .....	4-104
4.3.1	System overview .....	4-105
4.3.2	Wiring .....	4-107
4.3.3	Test sockets (diagnostics) .....	4-111
4.4	"ANA module" control board .....	4-112
4.4.1	System overview .....	4-113
4.4.2	Wiring .....	4-115
4.4.3	Bus interfaces .....	4-119
<b>5</b>	<b>Power Modules .....</b>	<b>5-121</b>
5.1	Description .....	5-121
5.2	Operating modes .....	5-123
5.3	Technical data .....	5-124
5.4	Current reduction/derating .....	5-128
5.4.1	Pulse frequency power modules .....	5-128
5.4.2	Temperature-dependent derating .....	5-130
5.4.3	Installation height-dependent derating .....	5-130
5.4.4	Calculation examples .....	5-131
5.5	Operating power modules from an unregulated infeed .....	5-134
5.6	Interfaces and terminals .....	5-136
5.6.1	Interface overview .....	5-136
5.6.2	Connectable cable cross-sections .....	5-137
5.6.3	Motor terminals A1 and A2 .....	5-138
<b>6</b>	<b>Infeed Modules .....</b>	<b>6-141</b>
6.1	Description .....	6-141
6.2	Interface overview .....	6-147
6.2.1	Interface overview, NE modules .....	6-147
6.2.2	5 kW UI module interface overview .....	6-150
6.2.3	Cable cross-sections that can be connected .....	6-152
6.2.4	Three-conductor connection (standard circuit) .....	6-153
6.2.5	Description of the interfaces and functions .....	6-154
6.3	Function overview and settings .....	6-162

6.4	Technical data .....	6-165
6.4.1	General information .....	6-165
6.4.2	Permissible duty cycles/derating .....	6-169
6.4.3	Technical data of the supplementary components .....	6-172
6.5	HFD reactor .....	6-174
6.5.1	Assignment of the HFD reactors/damping resistors to the NE modules .....	6-175
6.6	Monitoring module .....	6-179
6.6.1	Integration into the overall system .....	6-179
6.6.2	Technical data (supplement to the general technical data) .....	6-179
6.6.3	Mode of operation .....	6-181
6.7	DC link options .....	6-183
6.7.1	Capacitor module with 2.8 mF, 4.1 mF or 20 mF .....	6-183
6.7.2	Pulsed resistor module and unregulated line supply infeed with pulsed resistor .....	6-191
6.7.3	External pulsed resistors .....	6-194
6.7.4	Engineering information is applicable for UI 5 kW, 10 kW, 28 kW and PR module .....	6-197
<b>7</b>	<b>Line Supply Connection .....</b>	<b>7-199</b>
7.1	Line supply connection conditions for line supply infeed .....	7-199
7.2	Voltage matching .....	7-205
7.2.1	General .....	7-205
7.2.2	Line supply types .....	7-205
7.2.3	Minimum cross-sections for PE (protective conductor)/equipotential bonding conductor .....	7-209
7.2.4	Transformers .....	7-210
7.3	Overcurrent protective devices, transformers and main switch .....	7-215
7.3.1	Assignment of the line fuses to the NE modules .....	7-215
7.3.2	Assigning autotransformers to the I/R modules .....	7-220
7.3.3	Assigning isolating transformers to the I/R modules .....	7-224
7.3.4	Assignment of the isolating transformer to the UI modules .....	7-225
7.3.5	Assigning the main switches .....	7-226
7.3.6	Use of a leading contact for line isolating device .....	7-226
7.4	Line filters for I/R and UI modules .....	7-230
7.4.1	General information .....	7-230
7.4.2	Wideband line filter .....	7-232
7.4.3	Line Filter .....	7-234
7.4.4	Basic line filter for I/R modules .....	7-235
7.4.5	Adapter sets .....	7-238
<b>8</b>	<b>Important Circuit Information .....</b>	<b>8-239</b>
8.1	General information .....	8-239
8.2	Infeed modules .....	8-242
8.2.1	Connecting several NE modules to a main switch .....	8-242
8.2.2	Application, mode of operation and connection of the line contactor .....	8-243
8.2.3	Timing diagram for the ready signal in the I/R module .....	8-244
8.3	Axis expansion using a monitoring module .....	8-245
8.3.1	Connection example, power supply (standard) .....	8-245

8.3.2	Connection example, pulse enable .....	8-246
8.3.3	Description of the interfaces and functions .....	8-247
8.4	Drive modules .....	8-249
8.4.1	611 feed module with High Performance/High Standard .....	8-249
8.4.2	Description of the interfaces and functions .....	8-250
8.5	Start inhibit in the drive modules/safe standstill .....	8-252
8.5.1	Start inhibit applications .....	8-252
8.5.2	Mode of operation of the start inhibit .....	8-253
8.5.3	Connecting–up the start inhibit .....	8-254
8.5.4	Sequence and timing when using the start inhibit .....	8-256
8.5.5	Checking the start inhibit .....	8-257
8.5.6	Example "safe standstill" with contactor safety combination .....	8-258
8.5.7	Example, "safe standstill" for several drive groups .....	8-260
8.6	Application examples with SIMODRIVE 611 .....	8-262
8.6.1	Block diagram of the application example .....	8-262
8.6.2	Function description of the application example .....	8-263
8.6.3	Safety systems and Standards .....	8-266
8.7	Circuit examples =1 to =9 with SIMODRIVE 611 .....	8-268
8.7.1	Function description, circuit examples =1 to =9 .....	8-280
8.8	Information and instructions regarding applications with 611 digital/611 universal .....	8-294
8.8.1	Circuit example, 611 digital with SINUMERIK 840D .....	8-295
8.8.2	Circuits with 611 digital .....	8-295
8.8.3	Circuits with 611 universal HRS .....	8-296
8.9	Master/slave operation, SIMODRIVE 611 .....	8-297
8.10	Star–delta mode .....	8-298
8.11	Series reactor in the motor lead .....	8-301
8.12	Induction motor operation .....	8-303
8.12.1	Operating several induction motors in parallel .....	8-303
8.12.2	Selecting individual induction motors 611 .....	8-305
8.13	Operation when the power fails .....	8-307
8.13.1	Application and mode of operation .....	8-307
8.13.2	Functions .....	8-307
8.13.3	DC link buffering .....	8-310
8.14	SINUMERIK Safety Integrated .....	8-311
8.15	Examples of correctly and incorrectly connecting NE to the line supply .....	8-312
8.15.1	Three–conductor connection to the line supply .....	8-312
8.15.2	Six–conductor connection to the line supply .....	8-316
8.16	VPM Voltage Protection Module .....	8-322
8.16.1	General information .....	8-322
8.16.2	Integration .....	8-324
8.16.3	Mounting .....	8-333

<b>9</b>	<b>Cabinet Design and EMC</b> .....	<b>9-335</b>
9.1	Installation and connecting-up regulations .....	9-335
9.1.1	Shielded connecting plates .....	9-338
9.1.2	Mounting conditions, internal cooling .....	9-341
9.1.3	Two-tier equipment configuration .....	9-344
9.2	High-voltage test in the system .....	9-346
9.3	Safety of machinery – safety-related parts of controls according to EN ISO 13849-1:2008 .....	9-347
9.3.1	General information .....	9-347
9.3.2	Safety-related stop functions of electric drive systems according to DIN EN 61800-5-2 .....	9-347
9.3.3	Control modules safety-related circuit .....	9-348
9.3.4	Safety-related circuit infeed modules .....	9-350
9.3.5	Safety functions .....	9-351
9.3.6	Principle of STO in a safety function .....	9-352
9.3.7	Principle of SS1 in a safety function .....	9-353
9.4	Application examples .....	9-354
9.4.1	EMERGENCY STOP at a converter " SS1 .....	9-354
9.4.2	EMERGENCY STOP and protective door monitoring at a converter " SS1 .....	9-360
9.4.3	EMERGENCY STOP and protective door at several converters " SS1 .....	9-372
9.5	Using programmable safety components .....	9-377
<b>10</b>	<b>Connection Diagrams</b> .....	<b>10-379</b>
<b>11</b>	<b>Spare Parts and Service</b> .....	<b>11-383</b>
11.1	Fan .....	11-383
11.2	Terminals .....	11-386
11.3	DC link covers .....	11-386
11.4	Inspection of the DC link capacitors of the PM modules .....	11-387
<b>12</b>	<b>Dimension Drawings</b> .....	<b>12-391</b>
<b>A</b>	<b>Abbreviations and Terminology</b> .....	<b>A-459</b>
<b>B</b>	<b>References</b> .....	<b>B-463</b>
<b>C</b>	<b>Certificates/Declarations of Conformity</b> .....	<b>C-465</b>
<b>D</b>	<b>Index</b> .....	<b>D-479</b>





## Overview of the Drive System

### 1.1 Overview of SIMODRIVE 611

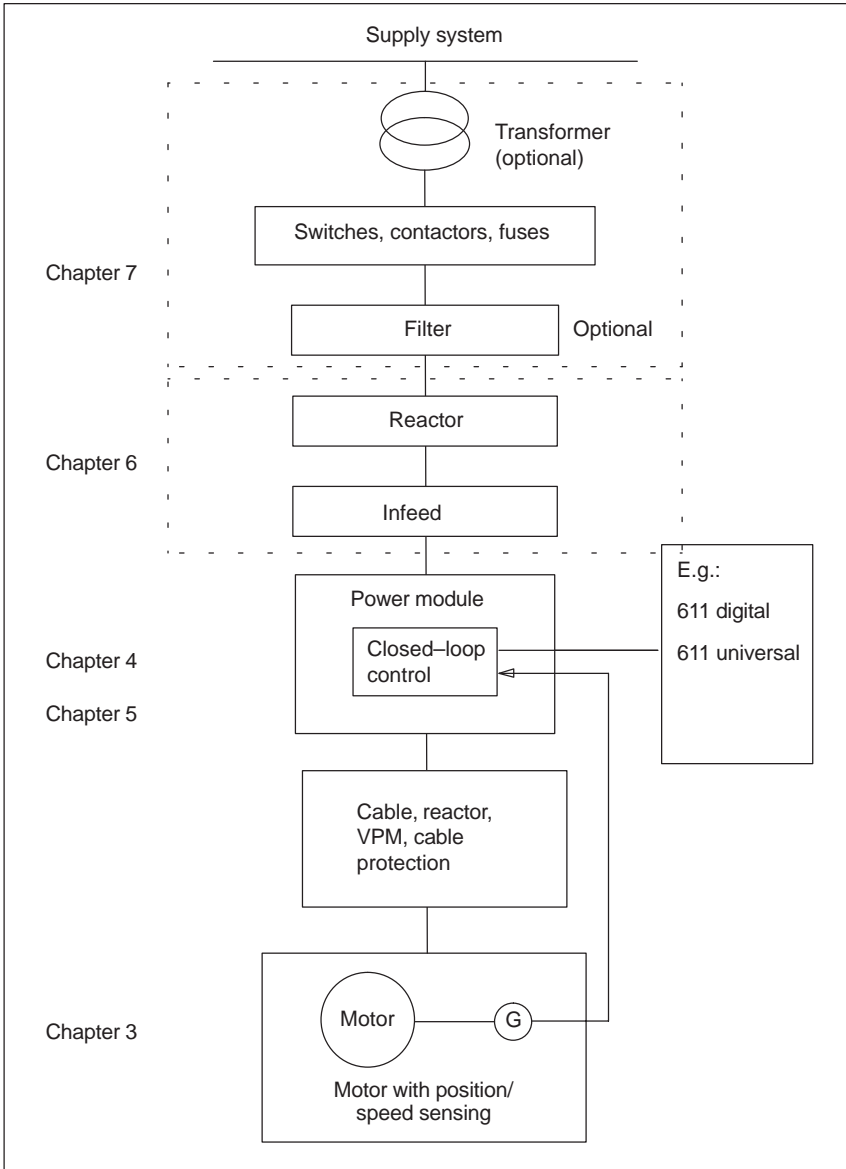

Fig. 1-1 Basic system structure

1.1 Overview of SIMODRIVE 611

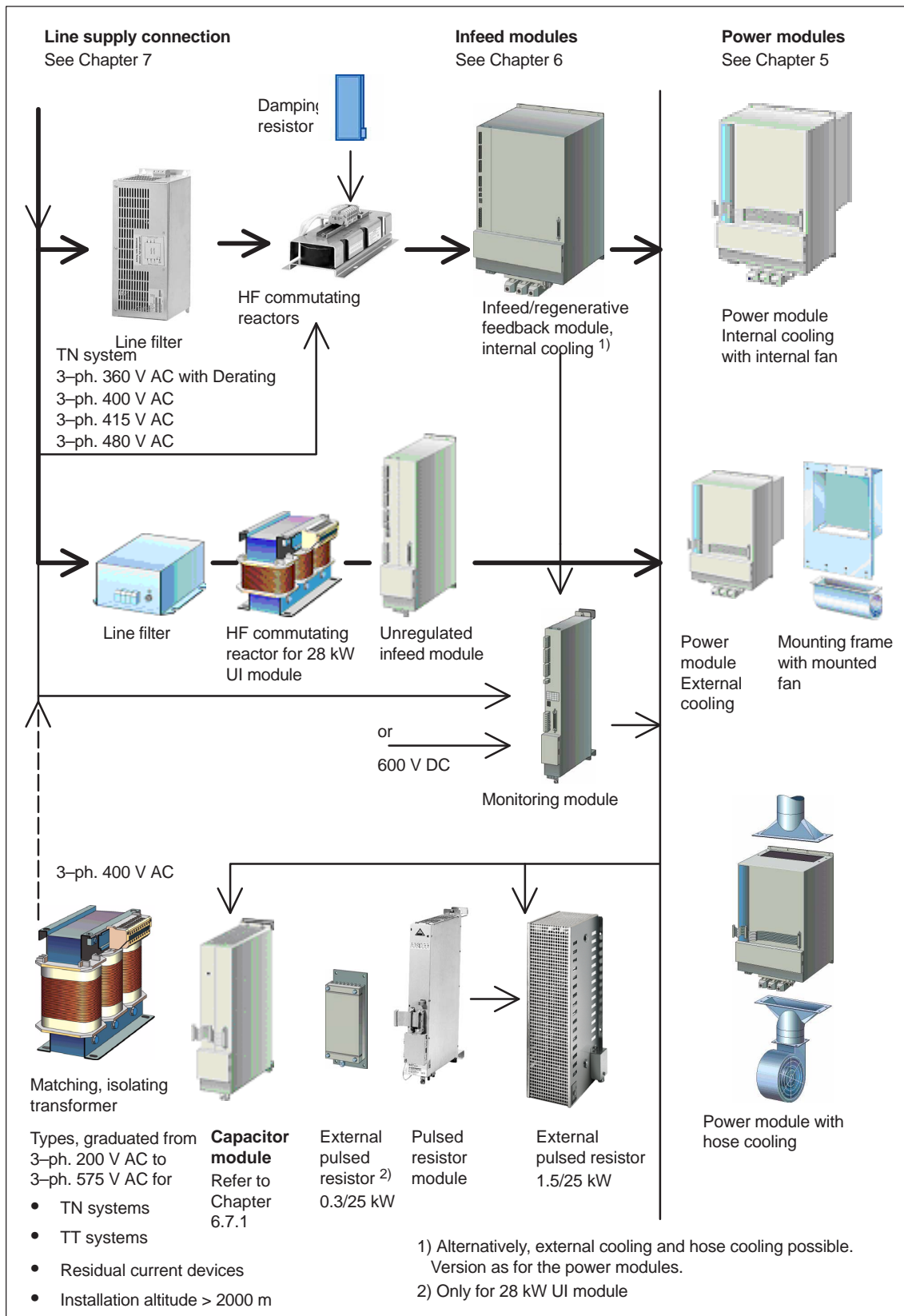

Fig. 1-2 Overview of the SIMODRIVE 611 drive system





Control units See Chapter 4	Motors See Chapter 3
<p><b>Control units with analog setpoint interface/PROFIBUS</b></p>  <p>For 1FT6/1FK/1FN/1FW6–1PH/1FE1 motors and induction motors</p> <ul style="list-style-type: none"> <li>• 1-axis version (with resolver only)</li> <li>• 2-axis version (resolver and motor encoder)</li> <li>• Standard: analog setpoint interface</li> <li>• Option modules: PROFIBUS DP or TERMINALS</li> </ul>	 <p>1FK7      Induction motor, e.g. 1LA</p>  <p>1PH4      1PH7</p>
<p><b>Control units with digital setpoint interface</b></p>  <p>For 1FT6/1FT7/1FK7/1PH/1PM/2SP1/1FE1 motors</p> <ul style="list-style-type: none"> <li>• 2-axis version (with High-Standard control) <ul style="list-style-type: none"> <li>– for motor encoders</li> <li>– additional measuring system, voltage signals</li> </ul> </li> </ul> <p>For 1FT6/1FT7/1FK7/1FN3/1FW6/1PH/1PM/2SP1/1FE1 motors</p> <ul style="list-style-type: none"> <li>• 1-axis version (with High-Performance control) <ul style="list-style-type: none"> <li>– for motor encoders</li> <li>– additional measuring system, voltage signals</li> </ul> </li> <li>• 2-axis version (with High-Performance control) <ul style="list-style-type: none"> <li>– for motor encoders</li> <li>– additional measuring system, voltage signals</li> <li>– EnDat and SSI encoders</li> </ul> </li> </ul>	 <p>1PH2      1FW6</p>  <p>1FE1      2SP1</p>  <p>1FN3</p>  <p>1FT      1PM</p>
 <p>For hydraulic linear axes (HLA/ANA)</p> <ul style="list-style-type: none"> <li>• 2-axis version</li> </ul>	 <p>Control valve for hydraulic linear axes (not included in the scope of supply)</p>

Fig. 1-3 Overview of the drive system

## 1.1 Overview of SIMODRIVE 611

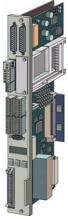
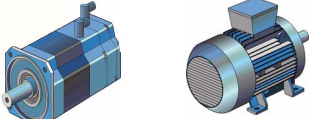
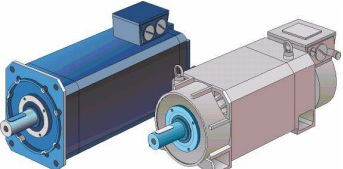
---

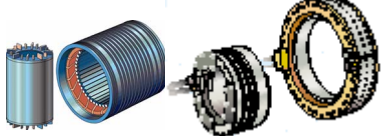
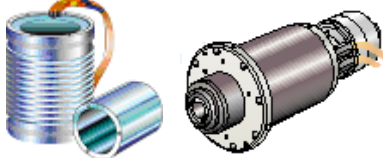
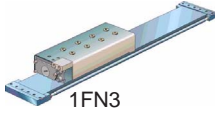
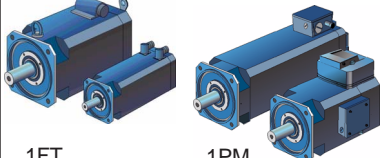
**Note**

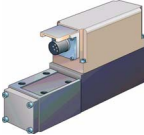
Siemens accepts the warranty for satisfactory and reliable operation of the drive system under the clear understanding that only original SIMODRIVE system components are used in conjunction with the original accessories described in this Configuration Manual and in Catalog NC 60.

The user must take the planning and engineering data into consideration.

Combinations that differ from the engineering specifications – where relevant, also in conjunction with third-party products, require a special, contractual agreement.

The converter system is designed for installation in control cabinets which conform with the relevant standards for processing machines, especially EN 60204.

---

**Description**

The converter system comprises the following modules (refer to Fig. 1-2 and 1-3):

- Transformer
- Switching and protective elements
- Line filter
- Commutating reactors
- Infeed modules
- Power modules
- Control units harmonized to the application technology/process and motor types
- Special modules and other accessories

Various cooling methods are available for the power-dependent line supply infeed and drive modules:

- Internal cooling
- External cooling
- Hose cooling

## 1.2 Engineering steps

---

### Note

Depending on the result of a hazard analysis/risk assessment to be performed according to the Machinery Directive 98/37/EC and EN 292-1, EN 954-1, EN ISO 13849-1 and EN 1050, the machinery construction company must configure, for all its machine types and versions, the safety-relevant control sections for the complete machine, incorporating all of the integrated components. These also include the electric drives.

---



---

### Note

When engineering SIMODRIVE 611, it is assumed that the motors to be used are known.

**Reference:** refer to the appropriate references for motors in the Appendix

---

### Procedure

A SIMODRIVE drive group is configured in two phases:

- Phase 1            Selecting the components            (refer to Fig. 1-4)
  - Phase 2            Connection configuration            (refer to Fig. 1-5)
- 

### Note

A selection guide is available for engineering the 6SN series, e.g.:

- NCSD Configurator

For additional information, please contact your local Siemens office.

The functions of SIMODRIVE control units are described with keywords in this Configuration Manual. Limit values may be specified in some cases. For additional details, please refer to the appropriate documentation.

Detailed ordering information and instructions are provided in Catalogs NC 60 and NC Z.

---

## 1.2 Engineering steps

**Phase 1 when engineering**

## Selecting components

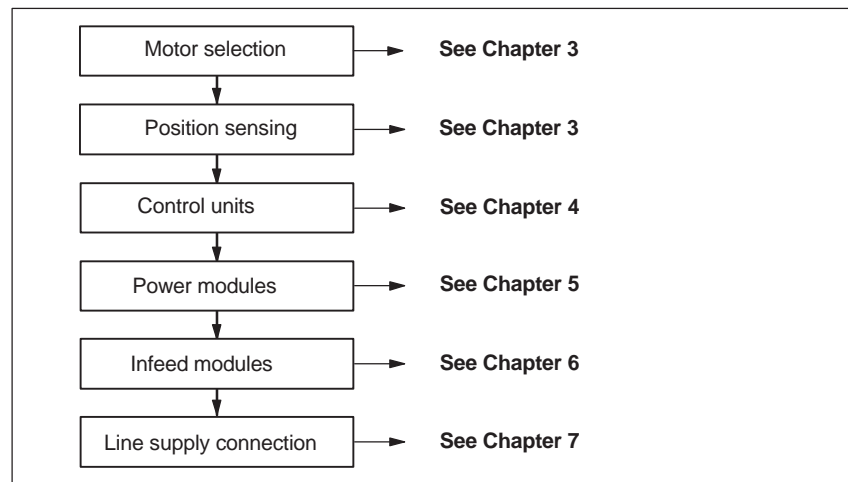

Fig. 1-4 Selecting components

**Phase 2 when engineering**

## Connecting-up

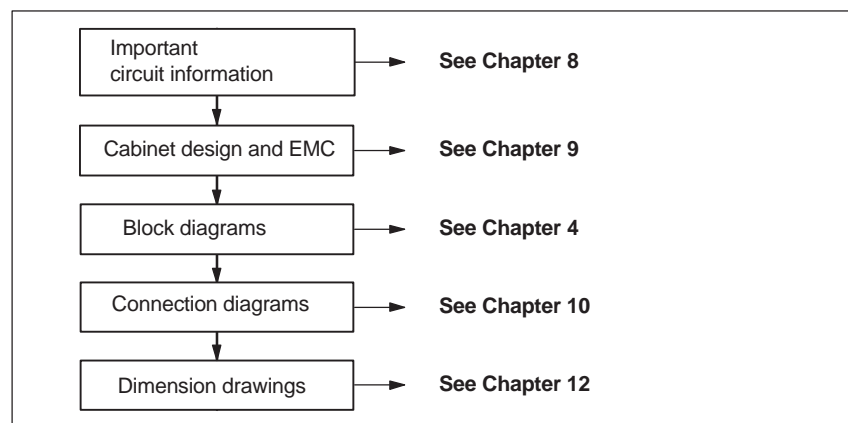

Fig. 1-5 Connecting-up

**Selecting cables, cable protection and switching devices**

Cables, cable protection and switching devices must be selected carefully taking into account the relevant regulations, standards and the requirements of the location where the system is installed.

**Reference:** /NCZ/ Catalog, Connecting System and System Components

**Reference:** /NSK/ Catalog, Low Voltage Switchgear

## 1.3 Engineering a drive

### Dimensioning

The power modules are selected depending on the motors to be used and the drive requirements (torque, speed ratio).

The infeed module is selected using the DC link power required by the group and the active power requirement of all of the power modules:

- Taking into account the coincidence factor (value determined from the load duty cycle or experience value). Not all of the motors are subject to a full load at the same time.

—> refer to Fig. 1-6

- The maximum permissible power to charge the DC link capacitors.

—> refer to Chapter 6.6 and Table 1-4

When calculating the DC link power  $P_{ZK}$ , refer to Fig. 1-6.

### Feed axes

In this case it must be noted that the DC link will be over-dimensioned if the motor outputs are simply added together:

- Because, from experience, feed axes are not operated at their rated torque and rated speed
- Because generally, the feed drives are not simultaneously operated

In the engineering sheet (refer to Fig. 1-6) to calculate the DC link power, these factors are taken into account by the speed ratio  $\tilde{n}/n_N$  (ratio between the operating speed and the rated speed) and coincidence factor  $K$ .

### Power supply rating

Gating and electronic points used to determine the load limits of the power supply. It is not possible to specify the power rating of an individual voltage source as several power supplies are coupled with one another. If the number of gating or electronic points is exceeded, an additional power supply must be used – the "monitoring module".

When determining the gating (AP) and electronic points (EP) refer to Chapter 6.6.

When calculating the power supply rating, refer to Chapter C.1.1.

### DC link capacitance

Every infeed module has a maximum value that applies when expanding the DC link capacitors. It must be ensured that the DC link capacitance in the selected drive group is not exceeded (refer to Table 1-1).

The sum (total) of the DC link capacitances (refer to Chapter C.1.1, Table 1-4) of all modules must be less than or equal to the charge limit corresponding to the following table of the infeed modules:



## 1.3 Engineering a drive

Table 1-1 Infeed modules

DC link power P <sub>ZK</sub> [kW]	Peak power [kW]	Infeed module Order No.	Charge limit [μF]
Infeed, unregulated			
≤ 5	10	6SN1146-1AB0□-0BA□	1200
≤ 10	25	6SN1145-1AA0□-0AA□	6000
≤ 28	50	6SN114□-1AA0□-0CA□	20000
Infeed/regenerative feedback module, regulated			
≤ 16	35	6SN114□-1BA0□-0BA□	20000
≤ 36	70	6SN114□-1BA0□-0CA□	20000
≤ 55	91	6SN114□-1B□0□-0DA□	20000
≤ 80	131	6SN114□-1BB0□-0EA□	20000
≤ 120	175	6SN114□-1BA0□-0FA□	20000

### 1.3.1 Calculation of the required DC link power ( $P_{ZK}$ ) for dimensioning the supply system, infeed unit

Steady-state operation:

$$P_{ZK} = P_{VSA\ ZK} + P_{MSD\ ZK}$$

$$P_{ZK} \leq P_{n\ \text{infeed module}}$$

- Feed axes with rotary motors

The following formula is used in the engineering sheet to determine the calculated power:

$$P_{\text{calc FD}} = 0.105 \cdot M_0 \cdot n_n \cdot 10^{-3} \text{ [kW]}$$

Where:

$P_{\text{calc FD}}$  calculated power for feed axes [kW]

0.105 factor  $2 \cdot \pi / 60$

For feed axes, calculated with  $M_0$

$M_0$  stall torque [Nm]

$n_n$  rated speed [RPM]

- Feed axes with linear motors

$$P = F_n \cdot V_{\text{MAX, FN}} \cdot 10^{-3} \text{ [kW]}$$

Where:

$F_n$  rated force [N]

$V_{\text{MAX, FN}}$  maximum velocity at the rated force [m/min]

The DC link power  $P_{VSA\ ZK}$  of the feed axes is calculated using the engineering sheet. The following factors must be taken into account:

- Speed ratio  $\tilde{n}/n_N$
- Coincidence factor  $K$  for the number of feed axes per area

If the exact values of the speed ratio  $\tilde{n}/n_N$  and coincidence factor  $K$  are known for the application in question, these should be used.

- Main spindles

For main spindle drives, the efficiencies must be included in the calculation and are roughly estimated using the following factors:

– Motors  $\leq 4$  kW

$$P_{\text{MSD ZK}} = 1.45 \cdot P_{\text{MSD motor shaft}} \text{ [kW]}$$

– Motors  $> 4$  kW

$$P_{\text{MSD ZK}} = 1.25 \cdot P_{\text{MSD motor shaft}} \text{ [kW]}$$

Where:

$P_{\text{MSD ZK}}$  DC link power for the main spindle drive [kW]

1.45 or 1.25 Assumed factor for the motor efficiency

$P_{\text{motor shaft MSD}}$  mechanical power [kW] used at the shaft of the main spindle motor

The rated motor current may not exceed the rated output current of the power modules. The maximum motor current must always be less than the maximum converter current.

## 1.3 Engineering a drive

## 1.3.2 Dynamic operation

The peak infeed power must also be calculated for acceleration and deceleration operations.

- Feed axes

The peak infeed power expected for feed axes can be roughly calculated according to the following formula:

$$P_{S\text{ FD}} = 0.6 V_{\text{DC link}} \cdot I_{\text{max}} \cdot \tilde{n}/n_N \cdot 10^{-3} \text{ [kW]}$$

Where:

$P_{S\text{ FD}}$  peak infeed power (calculated) [kW] for feed axes

0.6 empirical factor: DC link energy and and EMF of the motor are taken into account

$V_{\text{DC link}}$  DC link voltage [V] (600 V)

$I_{\text{max}}$  peak current [A] set for an axis

$\tilde{n}/n_N$  max. axis speed referred to the motor rated speed

- Feed axes with linear motors

$$P_{S\text{ FD}} = F_{\text{MAX}} \cdot V_{\text{MAX, FMAX}} + (I_{\text{MAX}}/I_N)^2 \cdot P_{\text{VN}} \text{ [kW]}$$

$$= 0.5 \dots 0.9 \cdot U_{\text{ZK}} \cdot I_{\text{MAX}} \cdot \tilde{v}/V_{\text{MAX, FMAX}} \cdot 10^{-3} \text{ [kW]}$$

Where:

$F_{\text{MAX}}$  maximum force [N]

$V_{\text{MAX, FMAX}}$  maximum velocity at the maximum force [m/min]

$I_{\text{max}}$  peak current [A] set for an axis

$I_N$  rated current [A] set for an axis

$P_{\text{VN}}$  rated motor power loss [kW]

$\tilde{v}/V_{\text{MAX, FMAX}}$  max. axis velocity referred to the maximum velocity at the maximum force

- Main spindles

The peak infeed power expected for main spindles is calculated according to the following formula:

– Motors  $\leq 4 \text{ kW}$

$$P_{S\text{ MSD}} = 1.45 \cdot P_{S\text{ motor shaft MSD}} \text{ [kW]}$$

– Motors  $> 4 \text{ kW}$

$$P_{S\text{ MSD}} = 1.25 \cdot P_{S\text{ motor shaft MSD}} \text{ [kW]}$$

Where:

$P_{S\text{ MSD}}$  peak power (calculated) for main spindles [kW]

1.25 or 1.45 factor to take into account the motor efficiency

$P_{S\text{ motor shaft MSD}}$  peak power [kW] used at the shaft of the main spindle motor

The sum of  $P_{S\text{ FD}}$  and  $P_{S\text{ MSD}}$  should be calculated from all of the feed axes and main spindles that are simultaneously operated. This calculated power must be less than the peak power of the regenerative feedback module.

### 1.3.3 Braking operation

With the UI modules, only deceleration with pulsed resistors is possible. With I/R modules, a regenerative feedback of excess energy to the supply system also occurs. For required braking operations in the event of a power failure, the braking module and pulsed resistors are also needed.

The regenerative feedback power is dependent on the available energy to be braked in the system:

- The mass
- Speed/velocity
- Braking ramps/braking time
- Efficiencies

1.3 Engineering a drive

1.3.4 Calculation of the DC link power (engineering sheet)

Axis name	Order No. of the motor	$n_N$ [RPM]	$M_0$ [Nm]	$I_N$ [A]	$I_0(\text{PM})$ [A]	$P_{\text{calcFD}}$ [kW]	$\tilde{n}/n_N$	$P_{\text{calcFD}}$ [kW]	$n/n_N$
<b>Range I for <math>P_{\text{calc FD}}</math> from 0...1.8 kW</b>									
1									
2									
3									
4									
5									
6									
Sum, range I									
<b>Range II for <math>P_{\text{calc FD}}</math> from 1.8...8.8 kW</b>									
1									
2									
3									
4									
5									
6									
Sum, range II									
<b>Range III for <math>P_{\text{calc FD}}</math> from 8.8...27 kW</b>									
1									
2									
3									
4									
5									
6									
Sum, range III									

Sum, range I	x	$K_I$	=				
Sum, range II	x	$K_{II}$	=		+		
Sum, range III	x	$K_{III}$	=		+		
					}	x 1.1 =	
							<b>DC link power <math>P_{VSA \text{ DC link}}</math></b>
							= <input style="width: 50px;" type="text"/> kW
							<b>DC link power <math>P_{ZK \text{ FD}}</math></b>
							+ <input style="width: 50px;" type="text"/> kW
							<b>DC link power <math>P_{ZK}</math></b>
							= <input style="width: 50px;" type="text"/> kW

Application scenario	Speed ratio $\tilde{n}/n_N$	Feed axes per range	Coincidence factor k per range
Feed drives	0.4 to 0.7	1	1
Robot drives	0.9 to 1	2	0.63
Robot drives with 1FT	1	3	0.5
		4	0.38
		5	0.33
		6	0.28

Fig. 1-6 Engineering sheet to calculate the DC link power PzK

### 1.3.5 Checking the permissible power supply rating

The infeed or monitoring module used offers a basic equipping of the electronic (EP values) and control power supply (AP values).

The following table is used to determine the power supply requirement of a drive line-up.

The number of modules used should be entered. The product from "Evaluation factor individual module" and "Number of modules" should be formed.

An (additional) monitoring module must be provided if one of these values is exceeded. The following tables should be used again for the module line-up, supplied from the monitoring module.

The monitoring module must be located to the left in front of the modules to be monitored.

1.3 Engineering a drive

Table 1-2 Engineering table for drive modules with SIMODRIVE 611 universal HRS/universal E HRS

SIMODRIVE 6SN11 power modules, type	Assessment factors							DC link capacitance  μF
	SIMODRIVE 611 universal HRS				SIMODRIVE 611 universal E HRS			
	Resolver		Encoder with 1 Vpp		Encoder with 1Vpp			
6SN1118 - - .NJ01	- .NK01	- .NH01			6SN1118 - - .NH11			
1-axis	2-axis	2-axis			2-axis			
<b>1-axis version</b>								
<b>6SN11 2.x - 1AA00 - 0HA1</b>	EP 1.1 AP 1.7	EP 1.4 AP 2.0	EP 1.5 AP 2.0		EP 1.5 AP 2.6			75
<b>6SN11 2 . - 1AA00 - 0AA1</b>	EP 1.1 AP 1.7	EP 1.4 AP 2.0	EP 1.5 AP 2.0		EP 1.5 AP 2.6			75
<b>6SN11 2 . - 1AA00 - 0BA1</b>	EP 1.1 AP 1.7	EP 1.4 AP 2.0	EP 1.6 AP 2.0		EP 1.6 AP 2.6			110
<b>6SN11 2 . - 1AA00 - 0CA1</b>	EP 1.1 AP 1.7	EP 1.4 AP 2.0	EP 1.6 AP 2.0		EP 1.6 AP 2.6			330
<b>6SN11 2 . - 1AA00 - 0DA1</b>	EP 1.2 AP 1.7	EP 1.4 AP 2.0	EP 1.7 AP 2.0		EP 1.7 AP 2.6			495
<b>6SN11 2 . - 1AA00 - 0LA1</b>	EP 1.7 AP 1.8	EP 1.7 AP 2.1	EP 1.7 AP 2.1		EP 1.7 AP 2.7			990
<b>6SN11 2 . - 1AA00 - 0EA1</b>	EP 2.7 AP 1.8	EP 2.7 AP 2.1	EP 2.7 AP 2.1		EP 2.7 AP 2.7			990
<b>6SN11 2 . - 1AA01 - 0FA1</b>	EP 2.7 AP 1.9	EP 2.7 AP 2.1	EP 2.7 AP 2.1		EP 2.7 AP 2.7			2145
<b>6SN11 2 . - 1AA00 - 0JA1 <sup>1)</sup></b>	EP 1.3 AP 1.9	EP 1.5 AP 2.1	EP 1.7 AP 2.1		EP 1.7 AP 2.7			2145
<b>6SN11 2 . - 1AA00 - 0KA1<sup>1)</sup></b>	EP 1.4 AP 1.9	EP 1.6 AP 2.1	EP 1.8 AP 2.1		EP 1.8 AP 2.7			4290
<b>6SN11 23 - 1AA02 - 0FA1 <sup>1)</sup></b>	EP 1.3 AP 1.9	EP 1.5 AP 2.1	EP 1.7 AP 2.1		EP 1.7 AP 2.7			2145
<b>2-axis version</b>								
<b>6SN11 2 . - 1AB00 - 0HA1</b>	EP 1.3 AP 2.1	EP 1.5 AP 2.4	EP 1.6 AP 2.4		EP 1.6 AP 3.0			150
<b>6SN11 2 . - 1AB00 - 0AA1</b>	EP 1.4 AP 2.1	EP 1.7 AP 2.4	EP 1.7 AP 2.4		EP 1.7 AP 3.0			150
<b>6SN11 2 . - 1AB00 - 0BA1</b>	EP 1.6 AP 2.1	EP 1.8 AP 2.4	EP 1.8 AP 2.4		EP 1.8 AP 3.0			220
<b>6SN11 2 . - 1AB00 - 0CA1</b>	EP 1.7 AP 2.1	EP 1.8 AP 2.4	EP 1.8 AP 2.4		EP 1.8 AP 3.0			660
Assessment factors of individual modules for the electronics points (EP) and gating points (AP) as well as permissible combinations of power modules and control units. Only combinations with entered EP and AP values are permissible. Data referring to the assessment factors for EP and AP refer to the encoder cable lengths that have been released. Enter the values into Table 1-4.					SIMODRIVE 611 universal HRS/E HRS with options When using EnDat absolute encoders, an additional 0.4 EP (electronic points) must be added for each encoder. For PROFIBUS-DP, an additional 0.6 control points (AP) should be added.			

1) With mounted fan or hose cooling.

Table 1-3 Engineering table for drive modules with digital interface

SIMODRIVE 6SN11 power modules, type	Assessment factors								DC link capac- tance  μF
	Control unit, digital								
	1-axis version High-Performance control 6SN1118 - - 0DJ21		2-axis version High-Performance control 6SN1118 - - 0DK21		2-axis version High-Standard control 6SN1118 - - 0DM31		- 0DM33		
<b>1-axis version</b>									
<b>6SN11 2 . - 1AA00 - 0HA1</b>	EP 1 AP 1.85		EP 1 AP 2.2			EP 1 AP 1.85	EP 1 AP 2.2		75
<b>6SN11 2 . - 1AA00 - 0AA1</b>	EP 1 AP 1.85		EP 1 AP 2.2			EP 1 AP 1.85	EP 1 AP 2.2		75
<b>6SN11 2 . - 1AA00 - 0BA1</b>	EP 1 AP 1.85		EP 1 AP 2.2			EP 1 AP 1.85	EP 1 AP 2.2		110
<b>6SN11 2 . - 1AA00 - 0CA1</b>	EP 1 AP 1.85		EP 1 AP 2.2			EP 1 AP 1.85	EP 1 AP 2.2		330
<b>6SN11 2 . - 1AA00 - 0DA1</b>	EP 1 AP 1.85		EP 1 AP 2.2			EP 1 AP 1.85	EP 1 AP 2.2		495
<b>6SN11 2 . - 1AA00 - 0LA1</b>	EP 1 AP 1.85		EP 1 AP 2.2			EP 1 AP 1.85	EP 1 AP 2.2		990
<b>6SN11 2 . - 1AA00 - 0EA1</b>	EP 1 AP 1.85		EP 1 AP 2.2			EP 1 AP 1.85	EP 1 AP 2.2		990
<b>6SN11 2 . - 1AA01 - 0FA1</b>	EP 1.75 AP 1.85		EP 1.75 AP 2.2			EP 1.75 AP 1.85	EP 1.75 AP 2.2		2145
<b>6SN11 2 . - 1AA00 - 0JA1</b> 1)	EP 1.5 AP 1.85		EP 1.5 AP 2.2			EP 1.5 AP 1.85	EP 1 AP 2.2		2145
<b>6SN11 2 . - 1AA00 - 0KA1</b> 1)	EP 1.5 AP 1.85		EP 1.5 AP 2.2			EP 1.5 AP 1.85	EP 1 AP 2.2		4290
<b>6SN11 23 - 1AA02 - 0FA1</b> 1)	EP 1 AP 1.85		EP 1 AP 2.2			EP 1 AP 1.85	EP 1 AP 2.2		2145
<b>2-axis version</b>									
<b>6SN11 2 . - 1AB00 - 0HA1</b>			EP 1 AP 2.8		EP 1 AP 3.4	EP 1 AP 2.8	EP 1 AP 3.4		150
<b>6SN11 2 . - 1AB00 - 0AA1</b>			EP 1 AP 2.8		EP 1 AP 3.4	EP 1 AP 2.8	EP 1 AP 3.4		150
<b>6SN11 2 . - 1AB00 - 0BA1</b>			EP 1 AP 2.8		EP 1 AP 3.4	EP 1 AP 2.8	EP 1 AP 3.4		220
<b>6SN11 2 . - 1AB00 - 0CA1</b>			EP 1 AP 2.8		EP 1 AP 3.4	EP 1 AP 2.8	EP 1 AP 3.4		660
Assessment factors of individual modules for the electronics points (EP) and gating points (AP) as well as permissible combinations of power modules and control units (digital). Only combinations with entered EP and AP values are permissible. The data referring to the assessment factors EP and AP refer to the encoder cable lengths that have been released for use. Enter the values into Table 1-4.					<u>Absolute encoder with EnDat interface</u> <ul style="list-style-type: none"> <li>• An additional 0.4 EP for each absolute encoder in the electronics area</li> <li>• SSI encoders require an external power supply - therefore no additional electronic/gating points</li> </ul>				

1) With mounted fan or hose cooling.



1.3 Engineering a drive

Table 1-4 Engineering sheet to calculate the DC link power PzK

Designation	Electronic points (EP)			Gating points (AP)			DC link capacitance					
	Assessment factor, individual module	Number of modules	Product	Assessment factor, individual module	Number of modules	Product	µF	Number of modules	Product			
<b>SIMODRIVE 611</b>												
UI module	5 kW/10 kW 10 kW/25 kW 28 kW/50 kW	} × 1 =		- 0.5 0.5	} × 1 =		150 440 990	} × 1 =				
I/R module	16 kW/21 kW 36 kW/47 kW 55 kW/71 kW 80 kW/131 kW 120 kW/175 kW			0.5 0.5 0.5 1 1			0.5 0.5 0.5 0.75 0.75			495 990 2145 2145 4290 1000 <sup>4)</sup>		
Monitoring module				0			0			1000 <sup>4)</sup>	× =	
Braking module				0.2 × =			0.1 × =			75 × =		
Capacitor module (central/distributed)				2.8 mF 0 4.1 mF 0			0 × = 0 =			2800 × = 4100 =		
HLA module				1.2 <sup>1)</sup> × =			1.5 × =			0		
Power module with control unit for FD/MSD (values from Tables 1-3)				× = × = × = × = × = × = × = × =			× = × = × = × = × = × = × = × =			× = × = × = × = × = × = × = × =		
Power module with SIMODRIVE 611 universal HRS (values from Table 1-2)		× = × = × = × = × = × =	× = × = × = × = × = × =	× = × = × = × = × = × =								
<b>SINUMERIK 810D powerline 2)</b>												
including integrated power modules												
CCU box 3LT with CCU 3		2 × =	4.5 × =	660								
CCU box 2LT with CCU 3		2 × =	4.5 × =	220								
<b>SINUMERIK 840D powerline with</b>						0						
NCU 561.4 6FC5 356 - 0BB12 - 0AE0		1 × =	3.8 × =									
NCU 571.4 6FC5 357 - 0BB12 - 0AE0		1 × =	3.8 × =									
NCU 572.4 6FC5 357 - 0BB23 - 0AE0		1 × =	3.8 × =									
NCU 573.4 6FC5 357 - 0BB34 - 0AE1		2.3 × =	5 (5.4) <sup>3)</sup> × =									
NCU 573.5 6FC5 357 - 0BB35 - 0AE0		2.3 × =	5 (5.4) <sup>3)</sup> × =									
		Sum, »Electronics« points maximum value 8	EP	Sum, »Gating« points maximum value 17	AP	Sum of the DC link capacitances						
		Maximalwert 3,5		Maximum value 7								

1) An additional 0.4 electronic points (EP) for each absolute value encoder EnDat.

2) An additional 0.3 gating points (AP) must be taken into consideration for each connected absolute value encoder with EnDat interface.

3) The value 5.4 is used for NCU 573.4/573.5 with link module.

4) Used only when the module is only supplied by the DC link.



## Drive line-up

A SIMODRIVE drive group has a modular configuration comprising line filter, commutating reactor, line supply infeed module, drive modules as well as, when required: monitoring, pulsed resistor and capacitor module(s).

Satisfactory operation is ensured only in conjunction with the components that are described in this Configuration Manual or published in the Catalog NC60 (Internet Mall) and with adherence to the required boundary/application conditions.

Failure to observe this along with improper use and application conditions can void your certifications, conformity declarations or warranty claims. In order to avoid contamination, the modules should be installed in a control cabinet with degree of protection IP 54.

Modules can also be arranged in several tiers one above the other or next to one another.

---

### Note

Tightening torques for screw connections are:

Screw size	—>	tightening torque
M3	—>	0.8 Nm
M4	—>	1.8 Nm
M5	—>	3.0 Nm
M6	—>	6.0 Nm
M8	—>	13.0 Nm
M10	—>	25.0 Nm
Tolerance	—>	0/+30%

For tightening torque deviations for connections to the HF/HFD reactors, see the specifications in Chapter 6.5.

The screws at terminal connections, e.g. DC link busbars, terminals should be checked and tightened each time that the equipment is transported or when performing maintenance work, however at the latest after 5 years.

---

### Note

According to IEC 61800-5-1, a PDS (Power Drive System) with leakage currents over 3.6 mA requires a secure ground connection (e.g. at least 10 mm<sup>2</sup> Cu or multiple connection) or an automatic shutdown in case of a ground connection fault.

---

The housings of the SIMODRIVE 611 converter system modules are enclosed and EMC-compatible as specified in EN 60529 (IEC 60529).

The electrical system is designed to comply with EN 50178 (VDE 0160) and EN 60204, and an EC declaration of conformity is available.

The connections in the module group, motor cables, encoder lines and bus lines must be made using preassembled MOTION-CONNECT lines (see Catalog NC 60).

## 2.1 Arrangement of the modules and their mounting

## 2.1 Arrangement of the modules and their mounting

## 2.1.1 Arrangement of the modules

The modules must be arranged in a particular layout. The following criteria must be taken into account:

- Function of the module
- Cross-section of the DC link busbar

The I/R or UI module is always located to the left of the module group at the beginning. The power modules (PM) are located to the right next to the I/R or UI modules (refer to Fig. 2-1).

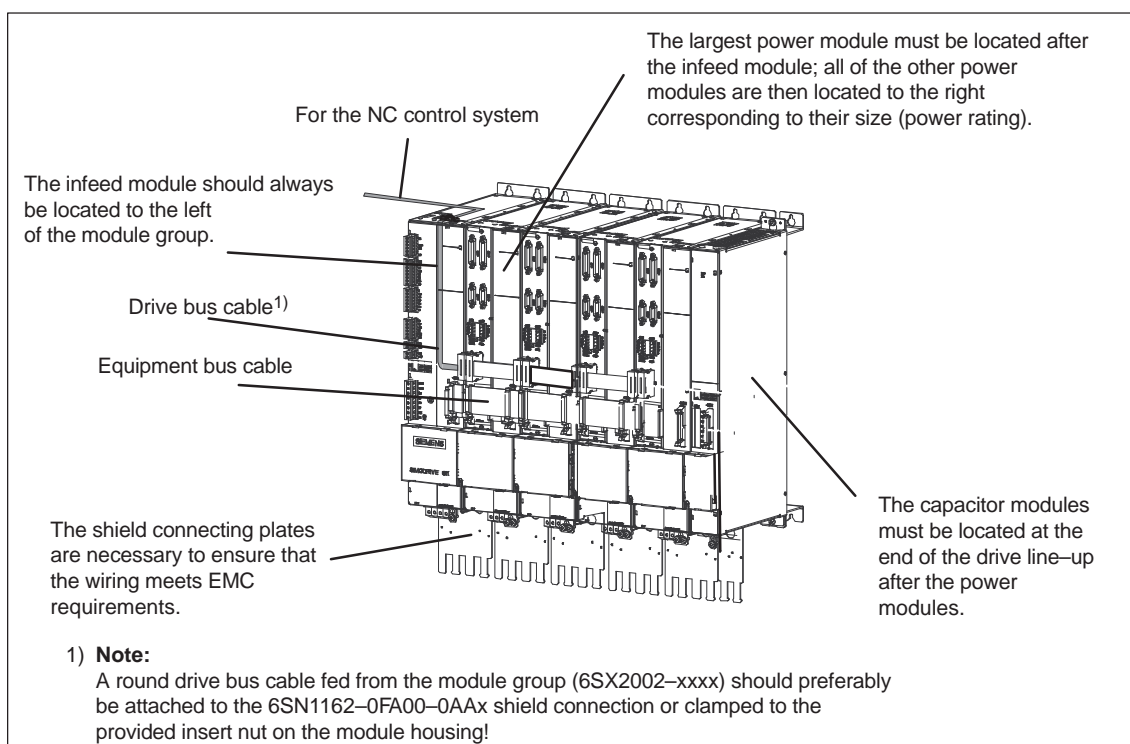

Fig. 2-1 Connection example

Due to the limited conductivity of the DC link busbars of the modules with module width  $\leq 150$  mm, the DC link power  $P_{ZK}$  of these modules must not exceed 55 kW. **Larger DC link busbars** must be used if this restriction cannot be complied with (refer to Fig. 2-2 and 2-3).

The DC link power  $P_{ZK}$  of the subsequent modules is calculated according to the engineering rule specified in Chapter 1.3.

The larger DC link busbars can be ordered as a set with Order No. [MLFB] 6SN1161-1AA02-6AA0. The set includes reinforced DC link busbars for module widths 50 mm, 100 mm and 150 mm.

The standard DC link brackets between the modules may not be changed, even when strengthened DC link busbars are used.

2.1 Arrangement of the modules and their mounting

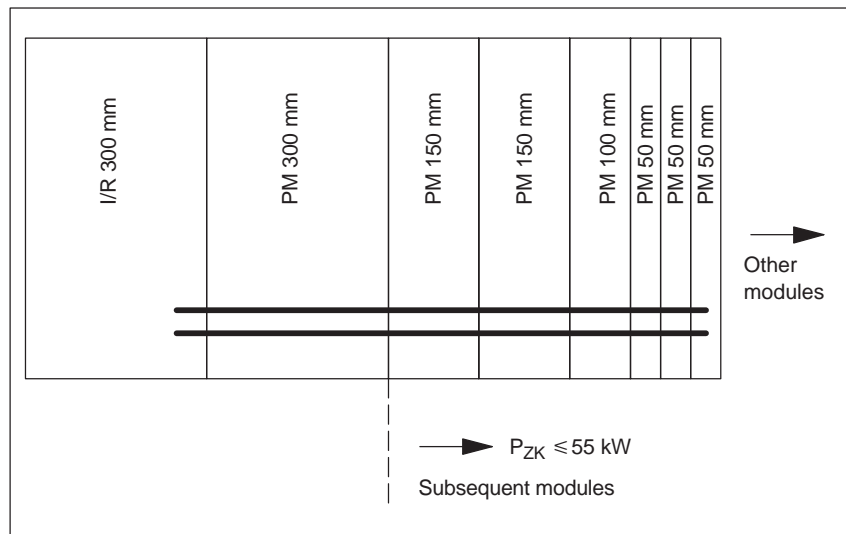

Fig. 2-2 Module group without larger DC link busbars

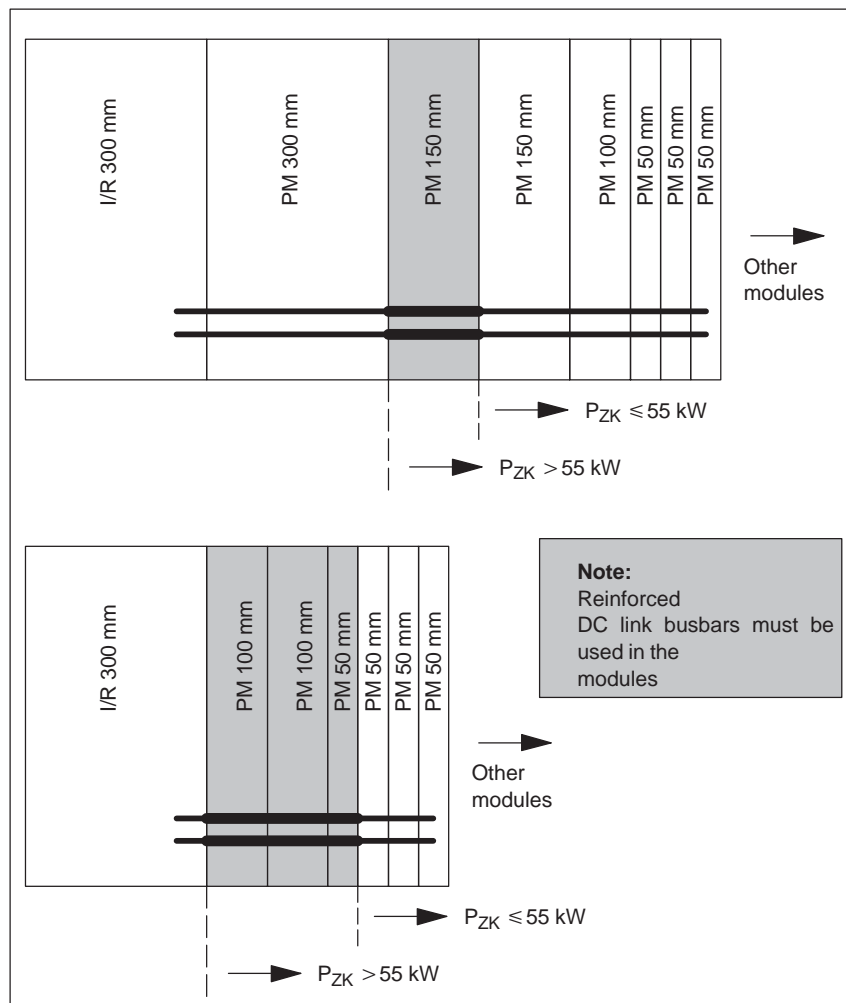

Fig. 2-3 Module group with larger busbars

### 2.1 Arrangement of the modules and their mounting

**Pulsed resistor module** Subject to certain conditions, several pulsed resistor modules can be connected in parallel (refer to Chapter C.1.1, Table 1-4).

**Drive bus** The drive bus length may not exceed 11 m.  
For more than six modules, control units, round cables must be used (refer to Chapter 2.1.2).

**Equipment bus** The equipment bus cable that is looped-through a drive group at an infeed or monitoring module may not exceed 2.1 m from the supply connection point. For a two-tier configuration, two equipment bus branches are possible, each with a maximum length of 2.1 m from the branch point at the supply connection point.

**Cable length** The permitted cable lengths depend on the used line filters, refer to the line filters in Section 7.4.



---

**Reader's note**

For cable lengths for SIMODRIVE POSMO SI/CD/CA, refer to

**Reference:** /POS3/ User Manual SIMODRIVE POSMO SI/CD/CA

---

## 2.1 Arrangement of the modules and their mounting

## 2.1.2 Mounting and installing the modules

When mounting and installing the SIMODRIVE modules on the rear cabinet panel, proceed in the following sequence:

1. Screw-in the retaining screws up to a clearance of approx. 4 mm from the surface of the mounting panel.
2. Locate the modules in the screws and then tighten the screws with 6 Nm.
3. Locate the DC link connecting bar in the adjacent module under the screws provided and tighten these screws with 1.8 Nm  $-0/+30\%$ .

The DC link covers must only be installed with the power turned off. Check the spring elements for exact positioning prior to installation. Covers with warped spring elements must be replaced.

**Drive bus**

For drives with a digital setpoint interface, a drive bus cable is required for the control and communications interface SINUMERIK 840D powerline (refer to Fig. 2-1).

Table 2-1 Order number assignment

Designation	Order number (MLFB)
for module width <ul style="list-style-type: none"> <li>• 50 mm</li> <li>• 100 mm</li> <li>• 150 mm</li> <li>• 300 mm</li> </ul>	6SN11 61-1CA00-0AA□ 6SN11 61-1CA00-0BA□ 6SN11 61-1CA00-0CA□ 6SN11 61-1CA00-0DA0 □ → 0: Ribbon cable □ → 1: Round cable (control units required from six axes onwards)
In order to jumper monitoring/pulsed resistor modules, select the drive bus cable to be 50 mm longer! <ul style="list-style-type: none"> <li>• 350 mm round long cable</li> <li>• 200 mm long ribbon cable</li> </ul>	6SN11 61-1CA00-0EA1 6SN11 61-1CA00-0FA0

**Equipment bus**

The electronics power supply between the individual modules is established using the equipment bus cable (refer to Fig. 2-1). The equipment bus cable is included in the scope of supply of the power module.

## 2.2 Ambient conditions

---

### Note

The components are insulated in compliance with DIN EN 50178.

- Overvoltage category III for industrial line supplies
- Degree of pollution II, especially no conductive pollution, moisture condensation is not permissible
- Installation altitude up to max. 2000 m above sea level
- Installation altitude 2000 m – 6500 m possible in conjunction with isolating transformer with neutral point on grounded the secondary side, grounded module housing.
- As a result of the "thinner air" (poor thermal dissipation), above 1000 m, the drive power must be derated (reduced). Refer to Chapter C.1.3 and 5.4.
- Star point of the line supply is directly grounded, the module housing is grounded.

According to EN 61800–5–1 and UL 508 only protective extra low voltages with safety separation may be connected at all connections and terminals of the electronic modules.

---



---

### Warning

**Any conductive dirt/pollution can result in the safe electrical separation being lost and can therefore result in hazards to personnel (electric shock).**

---

---

### Note

Appropriate measures (filter, waiting cycles, etc.) must be adopted to prevent contamination of the cooling system, because otherwise fan damage and thus loss of the cooling effect can occur.

---

Table 2-2 Ambient conditions

Designation		Description	
<b>Vibratory load</b>	<ul style="list-style-type: none"> <li>Long-term storage in the transport packaging</li> <li>Transport in the transport packaging</li> <li>Operation</li> </ul>	Class 1M2 in accordance with EN60721-3-1 Class 2M3 in accordance with EN60721-3-2 Test values: Frequency range: 10 Hz to 56 Hz With constant 0.075 mm deflection Frequency range: 58 Hz to 200 Hz With constant 1 g acceleration	
<b>Shock load</b>	<ul style="list-style-type: none"> <li>Long-term storage in the transport packaging</li> <li>Transport in the transport packaging</li> <li>Operation</li> </ul> Modules/devices without drive: Modules/devices with drive:	Class 1M2 in accordance with EN60721-3-1 Class 2M3 in accordance with EN60721-3-2 Test values: 5 g/11 ms 5 g/30 ms	
<b>Protection against ingress of solid foreign bodies and water</b>	<ul style="list-style-type: none"> <li>Modules with internal cooling</li> <li>Modules with external cooling/pipe cooling               <ul style="list-style-type: none"> <li>Heatsink in cooling area</li> <li>Electronics area</li> </ul> </li> </ul>	IP20 <sup>1)</sup>  IP54 IP20	
<b>Transportation and storage</b>	Temperature range	-40 °C – +70 °C	
	Dew-point temperature $t_d$ and relative air humidity U	Annual average	U = 75% td = 17 °C
		On 30 days (24 h) annually	U = 95% td = 24 °C
		These days should be naturally distributed over the complete year.	
	On the other days (<24 h) But maintaining the annual average	U = 85% td = 24 °C	
Relevant Standards	DIN EN 60068-2-1 DIN EN 60068-2-2 DIN EN 60068-2-3 DIN EN 61800-5-1		
<b>Ambient climatic conditions in operation</b>	Temperature range: for PM/NE modules (100% load): Current/power derating from +40 °C onwards:	0 °C – +55 °C  +40 °C  2.5 %/°C	
	Dew-point temperature $t_d$ and relative air humidity U	Annual average	U = 75% td = 17 °C
		On 30 days (24h) annually	U = 95% td = 24 °C
		These days should be naturally distributed over the complete year.	
	On the other days (<24 h) But maintaining the annual average	U = 85% td = 24 °C	
	Temperature change	Within one hour: Within 3 minutes:	max. 10 K max. 1 K
	Condensation	Not permissible	
	Atmospheric pressure	min. 860 mbar (86 kPa) max. 1080 mbar (108 kPa)	
Gases that can have a negative impact on the function	acc. to DIN 40046, Part 36 and Part 37		
Relevant Standards	DIN EN 60068-2-1 DIN EN 60068-2-2 DIN EN 60068-2-3 DIN EN 61800-5-1		

1) Supplementary measure is required, if the work to be carried out close to the DC link busbar (DC link cover at the last module).



## 2.3 Motor selection

### Selection

The Motor Configuration Manuals are used to select the drive motors.



#### Reader's note

You can find information on the following motors under the following link:

- Ordering documentation/overview of documents
  - → Printed documentation → Docu\_SIMOTICS
  - → DoConCD/User Manual Collection
- Links to download documents
  - Download documentation → SIMOTICS S servomotors
  - SIMOTICS M main motors
- Using documentation online (finding and searching in manuals/information)

<http://www.siemens.com/motioncontrol/docu>

The selection of the motor and the (brief) overload capability determines the size (rating) of the power module (refer to Chapter 4).

### VP module (VPM)

A voltage protection module (VPM) is required for motors 1FE1 and 2SP1 with an EMF > 800 V and maximum < 2 kV (> 565  $V_{\text{eff}}$  up to a maximum 1400  $V_{\text{eff}}$ ). When a fault condition develops, the VPM limits the DC link voltage at the drive converter.

Technical data and ordering data, refer to 8.16.



#### Reader's note

**Reference:** /PJFE/ Configuration Manual, 1FE1 Synchronous Built-in Motors  
 /BU/ Catalog NC 60  
 /PMS/ Configuration Manual ECO Motor Spindles for 2SP1 Main Spindle Drives

## 2.4 Position sensing/actual speed value sensing

**Description** The encoder system is used for precise positioning and to determine the actual speed value of the drive motor for the particular application. The resolution of the measuring system and the control board selected are decisive when it comes to positioning accuracy.

### 2.4.1 Position sensing, direct

#### Measuring systems that can be evaluated

- Rotary encoders with sine/cosine-shaped voltage signals.
- Linear scales with sine/cosine-shaped voltage signals.
- Distance-coded measuring systems (only SIMODRIVE 611 digital with NC)
- Measuring systems with sine/cosine-shaped voltage signals and EnDat/SSI interface (linear scales, singleturn and multiturn encoders)

The feed and main spindle drive modules can be supplied with a second measuring system evaluation, e.g. for a table-top measuring system or for spindle position sensing. A direct measuring system is needed, for example, when a high degree of accuracy has to be achieved on the workpiece with a linear scale or exact positioning is required with a multi-stage gear unit.

#### SIMODRIVE 611 digital, universal

The optimum measuring system for position detection is suitable for the evaluation of incremental encoders with sine/cosine voltage signals. It is possible to connect linear scales and rotary encoders with sinusoidal voltage signals to drive controls to operate 1FT6 and 1FK6 feed motors. The measuring signals supplied by the encoder system are evaluated with a high degree of resolution.

Example:

With a linear scale (20 µm grid constant) a position resolution of 0.01 mm (Digital High Performance control) is achieved.

### 2.4.2 Position detection, indirect

#### Measuring systems that can be evaluated

- Integrated incremental encoder in feed and main spindle motors
- Integrated absolute encoder with EnDat interface in feed motors
- Incremental encoder (SIMAG H) for sensing the rotary angle and the rotary angle velocity

SIMAG H is used for hollow-shaft applications with 1FE1 and 1PH2 direct drives and third-party spindles. It is also used as autonomous spindle encoder.



---

#### Reader's note

**Reference:** /PMH/ Measuring System for Main Spindle Drives

---

#### SIMODRIVE 611 digital/universal

When the SINUMERIK 810D/840D and SIMODRIVE 611 are digitally linked, the measuring systems are connected to the digital control units.

The controls are equipped by default with a connection for the measuring system integrated in the feed and main spindle modules. Together with the high resolution position detection of the digital controls, the integrated motor measuring system achieves a resolution of 4,000,000 increments per revolution (Performance Control). In many cases, also for the main spindle, it means that an additional C-axis encoder is not required.

The high-resolution actual position value is also transferred to the NC position control loops via the drive bus so that, given the right mechanical conditions, a direct table-top measuring system is no longer required.

The same secondary conditions/limitations apply for SIMODRIVE 611 universal and POSMO SI/CD/CA. The only difference is the drive link established using PROFIBUS DP.

### 2.4.3 Drive module

The drive modules comprise the following components: Power module, control unit, equipment bus cable and where relevant, a drive bus cable and option module.

The permissible combinations of power module and control unit are saved in the engineering tables (refer to Chapter C.1.1). Depending on the cooling method employed or the power module's size, additional cooling components have to be ordered or be provided by the user.

Depending on the application, the drive modules of the SIMODRIVE 611 converter system can function as feed, main spindle or induction motors, and comprise the power module, control unit, and drive bus cable components. Option modules can be added where applicable.

A drive module is created by inserting the control unit into the power module, e.g. for feed or main spindle applications.

The modular design of the drive modules allows a large number of applications to be implemented using only a small number of individual components.

---

#### Note

Combinations that differ from the engineering information and instructions – where relevant, also in conjunction with third-party products, require a special, contractual agreement.

We accept a warranty for our scope of supply up to the system interfaces that we have defined.

---

## 2.5 Power modules

A wide range of 1-axis or 2-axis power modules is available. These modules are graded according to the current ratings and can be supplied with three different cooling techniques. The range of power modules allows a seamless, modular and space-saving drive solution for:

- Small, compact machines (required feed torques and main spindle power ratings – e.g. 80 Nm at 500 RPM and 11 kW S1 at 1500 RPM) up to
- complex machining centers and automatic lathes – e.g. 115 Nm or 145 Nm at 2000 RPM and 100 kW S1 at 1500 RPM.

The current-related data refers to the series-preset values. The output currents can be limited by the control unit being used. After the control unit has been inserted, the retaining screws of the control unit front panel must be tightened in order to establish a good electrical connection to the module housing.

At higher clock cycle frequencies, ambient temperatures and installation altitudes above 1000 m above sea level, the modules must be derated. The appropriate pre-assembled cables are available to connect-up the motors. The ordering data is provided in Catalog NC 60, in the Motors Section.

Shield terminal plates are available to meet EMC requirements when using shielded power cables.

The equipment bus cable is included in the scope of supply of the power module. The drive bus cables must be ordered separately for the digital system.

### 2.5.1 Function of the power modules

The power module provides the required energy for the control boards and the connected motor. The power module is selected depending on the selected motor and the control board.

### 2.5.2 Connecting-up the power modules

The power module is grounded through the PE connecting screws.

The power module must be mounted on a grounded, low-resistance conductive mounting surface and must have a conductive connection to this mounting surface.

Power is fed-in through the DC link busbars.

#### Power module Internal cooling

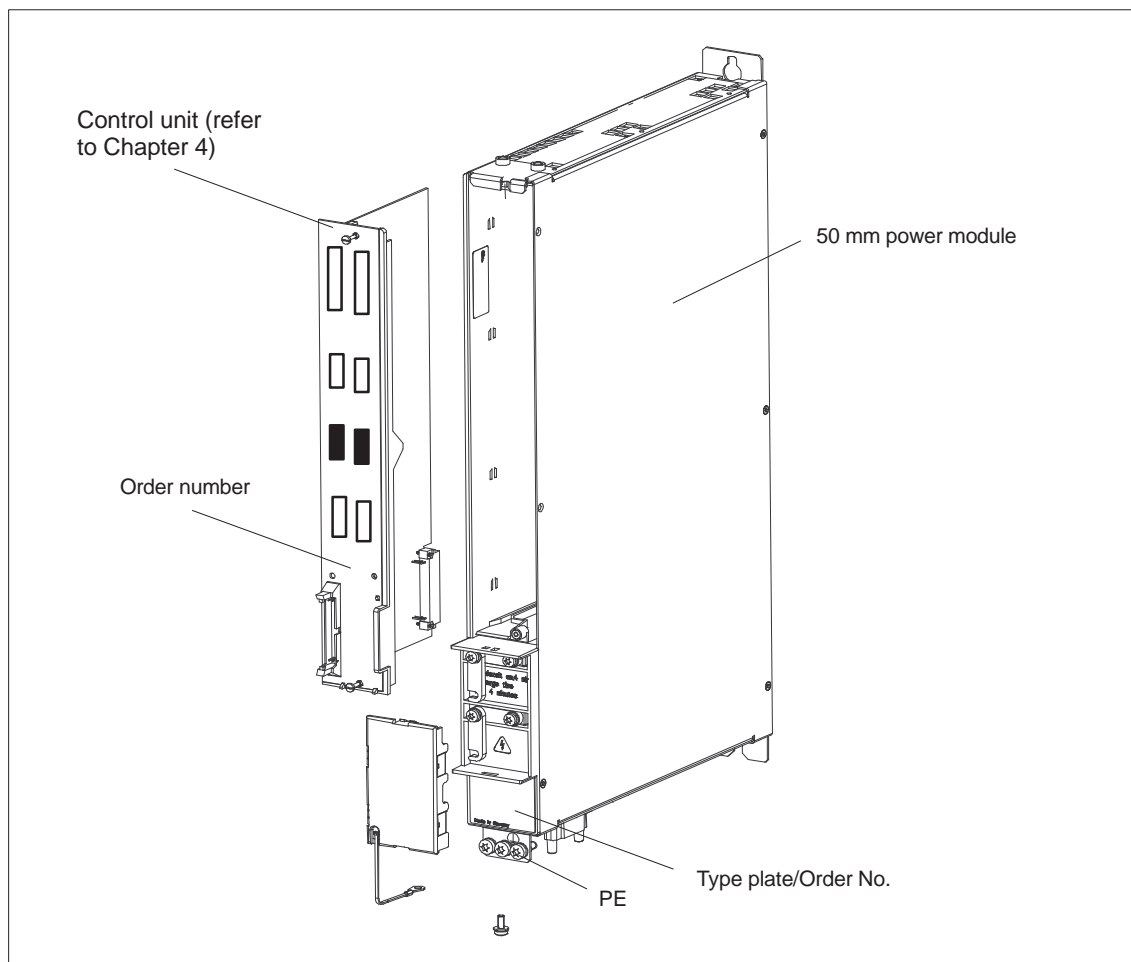

Fig. 2-4 Power module with control unit

## 2.6 Control units

### 2.6.1 General

The SIMODRIVE 611 control units use the power module to control the speed, torque and position of the attached motors. (Properties, for details refer to the module description in Chapter 4)

### 2.6.2 AC motors

The following AC motors, for example, can be operated synchronously or asynchronously:

- 1FT/1FK servo motors
- 1PH/1PM induction motors
- 1FE1/2SP1 built-in spindle motors
- 1 FW torque motors
- 1 FN linear motors
- Third-party motors (when suitable!)

### 2.6.3 Modules included in the scope of supply

#### For SINUMERIK 840D powerline

- **High Performance** as 2-axis or 1-axis control unit, optionally also with direct measuring system.
- **High Standard** as 2-axis control unit, optionally also with direct measuring system.
- **HLA/ANA** as 2-axis control unit for highly-dynamic "hydraulic axes" (modulating valves) or universal dynamic "analog interface" for components to be controlled externally.

#### For universal applications

- **SIMODRIVE 611 universal** in the system group or also for "standalone" devices.  
Various variants with analog or PROFIBUS DP interface. Variants with or without integrated positioning.
- **SIMODRIVE 611 universal HRS** with **Resolver** as 2-axis or 1-axis control unit.
- **SIMODRIVE 611 universal HRS** (high resolution) as 2-axis control units for encoders:
  - sin/cos or
  - EnDat or
  - TTL (only induction motors)

## 2.6 Control units

**For SINUMERIK  
840Di powerline  
SINUMERIK 802D**

- **SIMODRIVE 611 universal E HRS** (economic high resolution) as 2–axis control units for encoders:
  - sin/cos or
  - EnDat or
  - TTL (only PROFIBUS DP interface for the controller)

Table 2-3 Comparison table

Control unit with	611 universal	High Standard Closed-loop control	High Performance Closed-loop control
Max. electrical fundamental frequency for motor	1400 Hz	600 Hz	1400 Hz
Encoder limit frequency, motor encoder	350 kHz	200 kHz	350 kHz (420 kHz) <sup>1)</sup>
Encoder limit frequency, motor encoders for Safety Integrated	–	200 kHz	300 kHz (420 kHz) <sup>1)</sup>
Encoder limit frequency, direct measuring system	350 kHz	200 kHz	350 kHz (420 kHz) <sup>1)</sup>
Encoder limit frequency resolver	12-bit 432 Hz 14-bit 108 Hz	–	–
Encoder limit frequency, direct measuring system for Safety Integrated	–	200 kHz	300 kHz (420 kHz) <sup>1)</sup>
Pulse multiplication: <ul style="list-style-type: none"> <li>• Incremental encoder</li> <li>• Resolver (14/12-bit)</li> </ul>	2048 4096/16348	128 –	2048 –
Maximum cable length, encoder with voltage signal	50 m	50 m	50 m (20 m) <sup>1)</sup>
Smooth running characteristics (measure of the position fluctuation by $n_{set}$ in the range 10% $n_N$ referred to a 10 mm spindle pitch/motor revolution) <ul style="list-style-type: none"> <li>• 1-axis version</li> <li>• 2-axis version</li> </ul>	0.1 $\mu$ m 0.1 $\mu$ m	0.2 $\mu$ m 1.5 $\mu$ m	0.1 $\mu$ m 0.1 $\mu$ m

- 1) The following limitations/secondary conditions apply for 420 kHz:
- Cable to be used: Siemens cable, Order No. [MLFB]: 6FX2002-2CA31-1CF
  - Maximum permissible encoder cable length: 20 m
  - Encoder characteristics: "–3dB cutoff frequency" greater than or equal to 500 kHz  
Examples for permissible encoders: ERA 180 with 9000 pulses/revolution and ERA 180 with 3600 pulses/revolution manufactured by Heidenhain
  - Amplitude monitoring up to 420 kHz is active.

**2.6.4 NCU box for SINUMERIK 840D**

If the digital drive modules are operated in conjunction with the SINUMERIK 840D CNC control system, then the NCU box must be located immediately to the right of the infeed module.

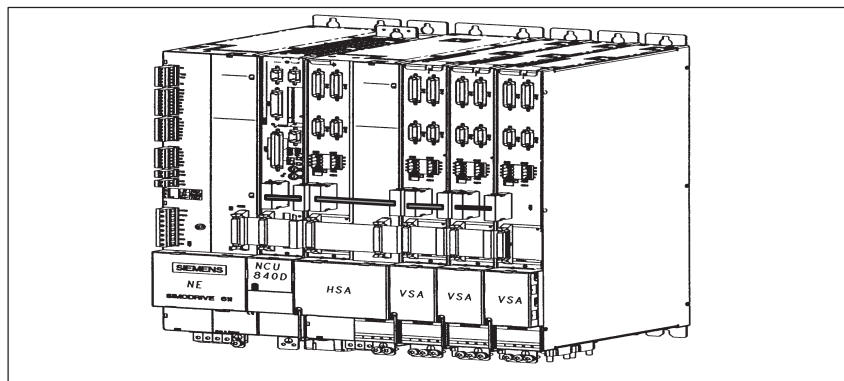

Fig. 2-5 Digital closed-loop control with SINUMERIK 840D

## 2.7 Infeed modules

<b>Application</b>	<p>The infeed modules are used to connect the drive group to the line supply.</p> <p>The infeed modules generate the DC voltage for the DC link from the following possible line supply voltages:</p> <ul style="list-style-type: none"> <li>• 3-ph. 400 V AC <math>\pm 10\%</math> 50 Hz/60 Hz,</li> <li>• 3-ph. 415 V AC <math>\pm 10\%</math> 50/60 Hz,</li> <li>• 3-ph. 480 V AC + 6% –10% 50 Hz/60 Hz</li> </ul> <p>In addition, the electronic voltages (<math>\pm 24</math> V, <math>\pm 15</math> V +5 V, etc.) are made available centrally to the drive modules and to the SINUMERIK 840D or SINUMERIK 810D – arranged as group – via the equipment bus.</p>
<b>Different line supply</b>	<p>If the infeed modules are connected to a line supply other than a TN line supply, or a line supply that is not equipped with suitable residual current protective devices, then an additional transformer with separate windings in vector group yn is required according to selection table 7-8.</p> <p>The HF commutating reactor is also required for the regulated infeed/regenerative feedback module when there are upstream transformers.</p> <p>An appropriate matching transformer is also required for line supply voltages of 3-ph. 200 V/220 V/240 V/440 V/500 V/575 V AC 10% 50 Hz/60 Hz.</p> <p>Please observe the appropriate information and instructions for the 300 mm modules.</p>
<b>Module arrangement</b>	<p>For the arrangement of the infeed module, see Chapter 2.1.1.</p> <p>A minimum lateral clearance of 50 mm must be maintained between the module groups mounted at the same height.</p>
<b>Heat dissipation</b>	<p>The necessary cooling components, such as externally mounted fan and/or air baffle plates for a module width of 100 mm to guide the air at the module heat sinks must be separately ordered when required. For other module widths, the baffle plates should be appropriately produced according to the drawing, see the dimension drawing in Chapter 12.</p> <ul style="list-style-type: none"> <li>• Internal cooling           <p>The infeed modules can be ordered with module-internal heatsinks for cooling inside the control cabinet. The 300 mm wide modules, that can be ordered for pipe cooling, also offer the option of connecting a pipe for direct air cooling.</p> </li> <li>• External cooling           <p>Alternatively, infeed modules with heat sinks outside the housing for external cooling are available. When mounting, the heatsinks are inserted through the openings at the rear of the cabinet. Cooling is then realized on the customer side. For this type of configuration, a mounting frame is required for each module (refer to Fig. 2-9).</p> </li> </ul>



## 2.7 Infeed modules

### Dimensions

All modules have a grid dimension of 50 mm for the width. All modules have a standard height of 480 mm. Note that the dimensions for air baffle plates, shield connecting plates, built-on fans and hose cooling must also be taken into account.

- Width: 50 mm grid dimension
- Relative to the mounting plane, the depth of all modules (without connectors and optional machine-mounted accessories) is:
  - Internal cooling or hose cooling: 288 mm
  - External cooling: 231 mm, in this case, the heatsink penetration depth must be taken into account for the cooling duct.

### 2.7.1 Cooling components

Depending on the cooling method used, additional fan units and fan components, specifically designed for the system, must also be ordered.

A differentiation is made between three different cooling types.

1. For internal cooling, the complete power loss remains in the electrical cabinet in the form of heat.
2. With external cooling, the power module power loss (thermal) is externally dissipated in the form of heat and the power loss of the control unit is internally dissipated in the form of heat.
3. For pipe cooling, version with 300 mm wide modules with internal cooling, the complete power loss in the form of heat is conducted to the outside using a pipe connected to the module.

The mounted fan is connected directly to the control cabinet line supply.

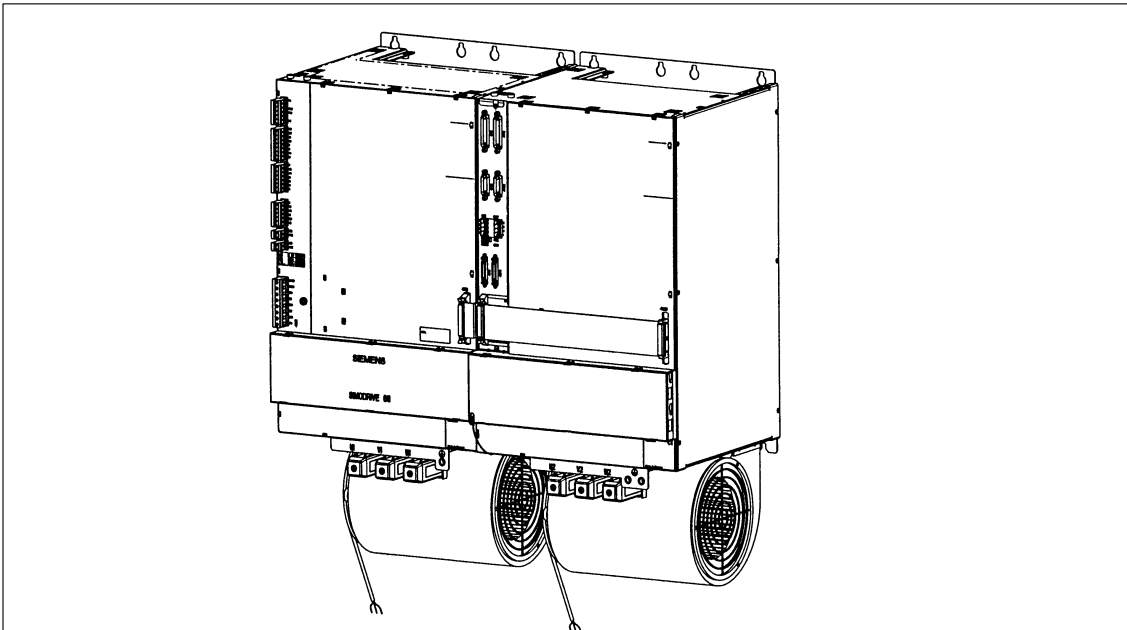

Fig. 2-6 Standard system design for 300 mm wide modules with mounted fan for internal cooling



#### Warning

The fan may only be commissioned if it is electrically connected to the module housing (PE fan via module housing).



#### Caution

If the fan has an incorrect direction of rotation (see arrow) then cooling is not guaranteed!

## 2.7 Infeed modules

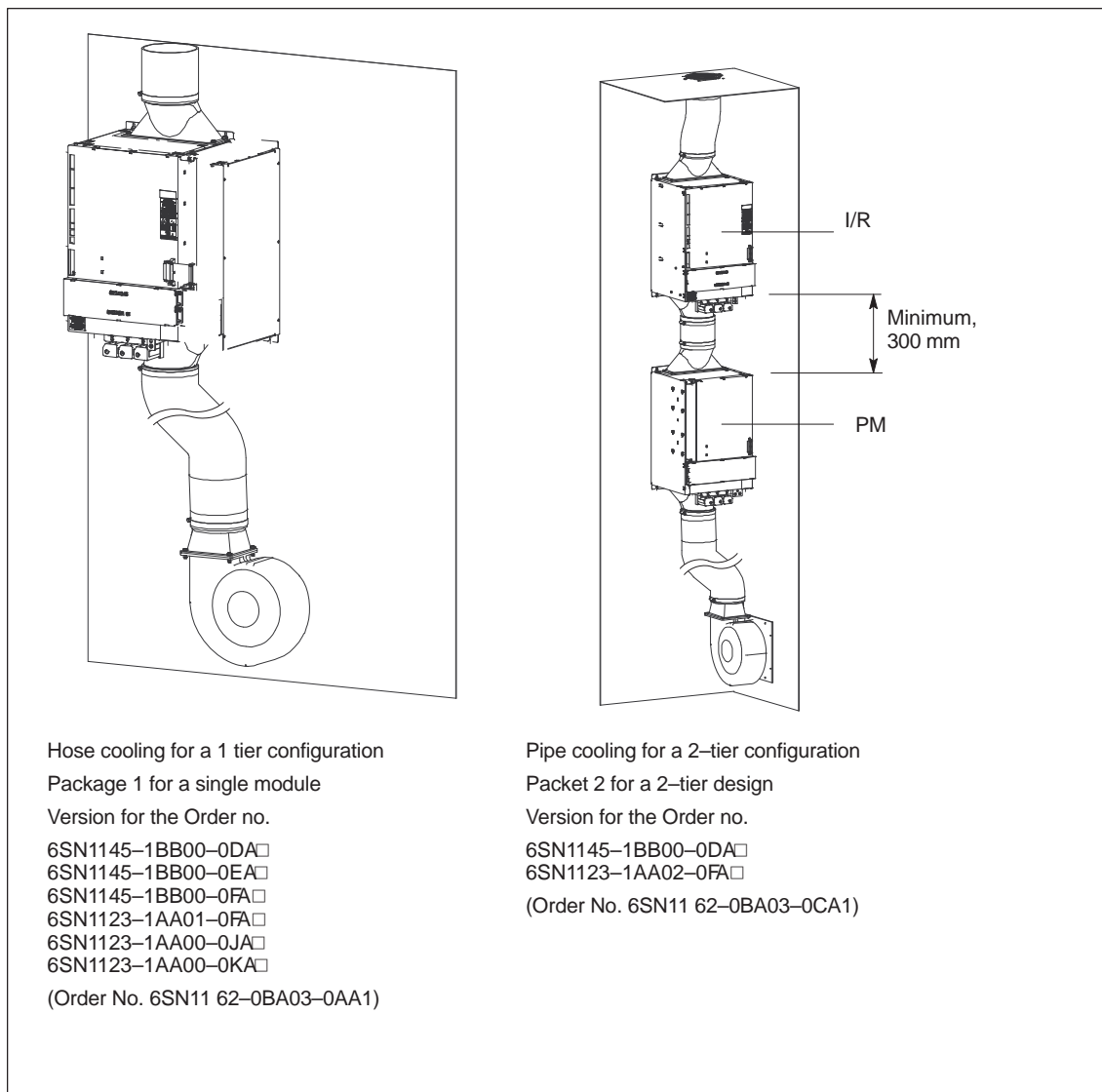

Fig. 2-7 System configuration with hose cooling (only for 300 mm wide modules)

The 2-tier design with pipe cooling is only permissible for the combination of modules, order no. 6SN1145-1BB00-0DA□ at the top and 6SN1123-1AA02-0FA□ at the bottom.

**Note**

DC link connection, refer to Chapter 9.1.3.

For connection details for the DC link adapter set, refer to the dimension drawing in Chapter 12.

### 2.7.2 Internal cooling

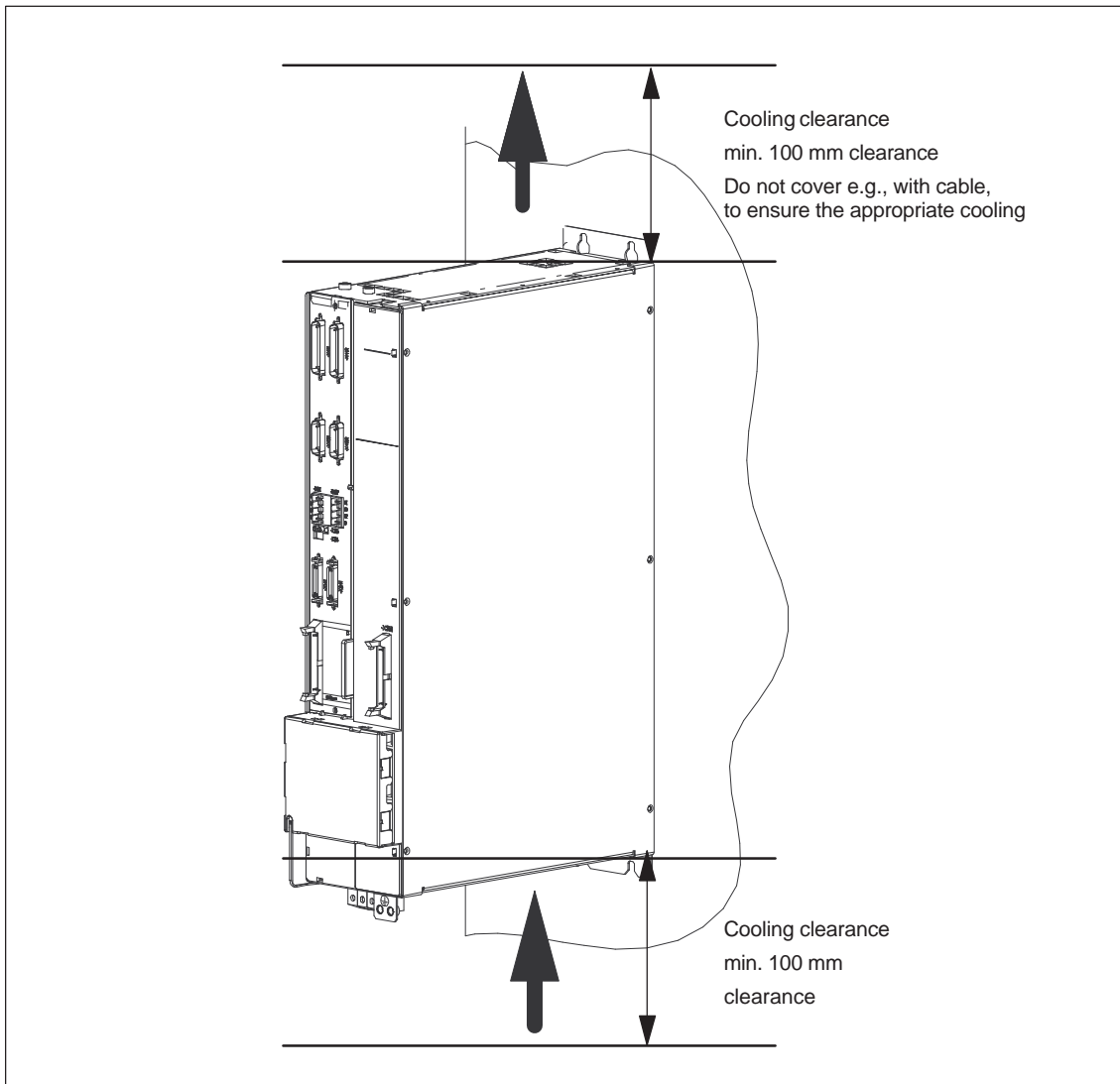

Fig. 2-8 Power module with inserted control unit, internal cooling

#### Note

The power loss is dissipated in the cabinet and must therefore be taken into account when engineering/dimensioning the cabinet cooling.

### 2.7.3 External cooling

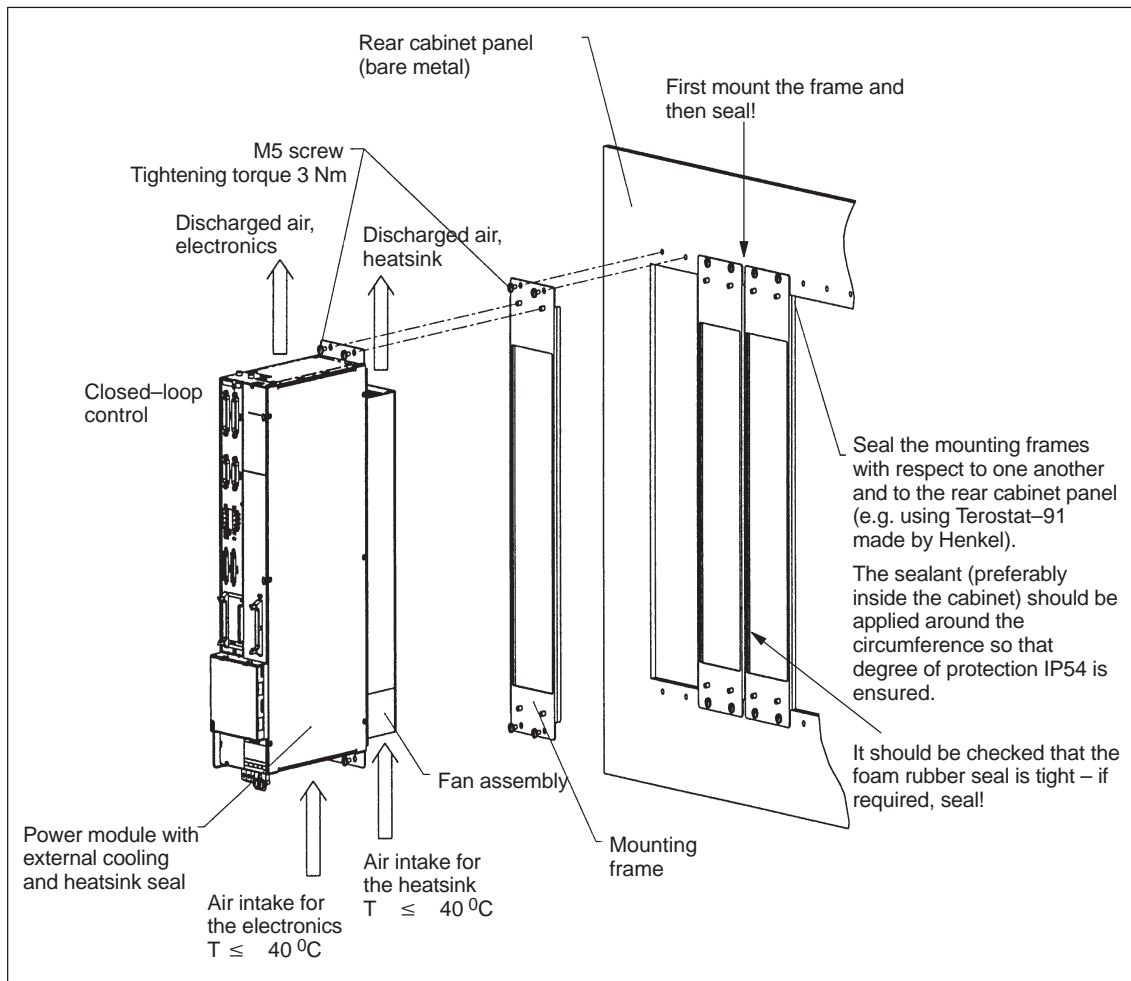

Fig. 2-9 Power module with inserted control unit, external cooling

#### Note

Refer to Fig. 2-9 for the air flow direction and the dimension drawing in Chapter 12 for the ventilation space. The dimensions of the installation frame are presented in the dimension drawing in Chapter 12.

#### Notice

For external heatsinks and fans, a high degree of pollution restricts the module cooling. This can cause the temperature monitoring function in the power module to respond. The heatsinks and fans must be checked for accumulated dirt at regular intervals.

**Clean when required!**

### Configuration information

For external cooling, the module heatsinks extend through the mounting plane in the electrical cabinet and can therefore dissipate power loss into an external cooling circuit.

The breakout in the mounting panel can be made for each module or also for a complete group of modules. For a breakout for the complete group of modules, the specific mounting frames for the modules should be used. For 300 mm wide modules, the appropriate mounting frame must be used (Order No.: 6SN1162-0BA04-0EAO). The dimension drawings for the breakouts are provided in Chapter 12.

The mounting frames should be installed from the inside of the cabinet or from the rear. This also then guarantees the necessary mounting surface for EMC.

#### Note

The dimensions of the recesses for the reinforcing ribs have different lengths. Ensure that the modules are mounted/installed in a standard way.

### Seal

The reinforcing ribs of the mounting frames, that are rounded-off towards the rear, have seals on both sides. A sealant (e.g. Terostat-96 made by Henkel) must be used to seal the edges of the mounting frames in contact with the mounting panel. Degree of protection IP 54 is achieved when the sealant is correctly applied.

### Mounted fans for 300 mm wide modules

The fan cable must be fed into the electrical cabinet using a PG gland to ensure that the degree of protection is maintained.

The mounting panel must be sealed at the rear panel of the electrical cabinet so that a closed space or duct is created. Depending on how the cabinet is mounted (free-standing or installed in the machine), this must be cooled/ventilated via the roof/base assembly or the rear panel.

Make sure that the air inlet is unobstructed. The distance to the side walls must be at least 50 mm.

Fans must not draw in any air contaminated with cooling lubricant nor must they be sprayed with cooling lubricant, as this will considerably reduce their service life because of them sticking and cooling ducts can become clogged.

For further information refer to the device-specific technical user documentation.

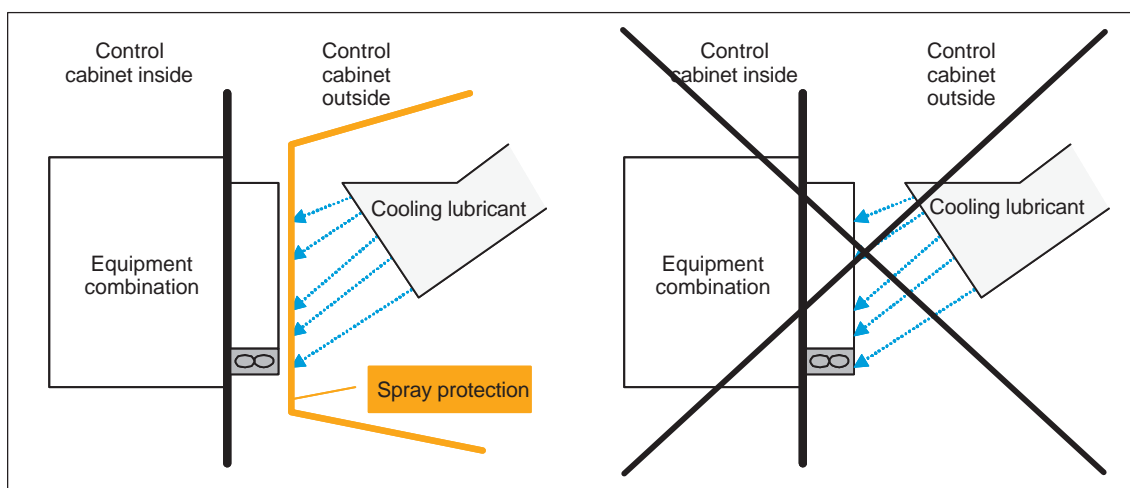

Fig. 2-10 Spray protection for external cooling



## 3.1 Motor selection

The motor type should be selected according to the mechanical and dynamic requirements placed on the motor.

### 3.1.1 Motor protection

To protect the motors, the specified motor protection circuit breakers should be connected downstream, which only switch a signal contact when the motor has an overload condition.

If the motor is separated from the power module with the pulses enabled during operation, then there is the danger that the power module will destroy itself together with the control unit. Because of the harmonic oscillations in the current, set approx. 10% above the rated current!

### 3.1.2 Motors with holding brake

#### Description

The holding brake mounted onto the motors is used to brake the motor when it is already at a standstill. In an emergency, it can also additionally reduce the braking travel. The holding brake is not an operational brake.

---

#### Notice

The motor holding brakes should only be actuated at standstill.

If the holding brake is operated during operation or while the motor is turning, this results in increased wear and shortens the lifetime of the holding brake. This is the reason that failure of the holding brake must already be taken into consideration when engineering the system. A hazard analysis must be performed.

---

#### Suspended (hanging) loads



---

#### Danger

Special attention and consideration must be given when holding brakes are used for suspended (hanging) loads (injury, crushing, possibility of death, machine damage) as this application represents a high potential hazard.

---



## 3.2 Motor encoder

### General

The motors are equipped with various encoder systems to sense the rotor position and speed.

**Reference:** refer to Appendix B in the relevant Configuration Manual of the motors

The assignment of the SIMODRIVE units to the servo/main spindle motor types and encoder systems is shown in the Table 3-5.

Depending on the requirements, various types of encoder are used and processed in the appropriate modules:

- sin/cos 1 Vpp or EnDat encoder
- SSI encoder (only SIMODRIVE 611 High Performance, High Standard, HLA/ANA)
- Resolver (only SIMODRIVE 611 universal)
- TTL encoder (only SIMODRIVE 611 universal with induction motors)

Induction motors can also be operated without encoders.

The modules provide high encoder resolutions with internal pulse multiplication.

### Recommended encoder signals for fault-free operation with sin/cos 1 Vpp

The following encoder signals are recommended for fault-free operation:

- For track signals A+, A-, B+, B-, C+, C-, D+ and D-

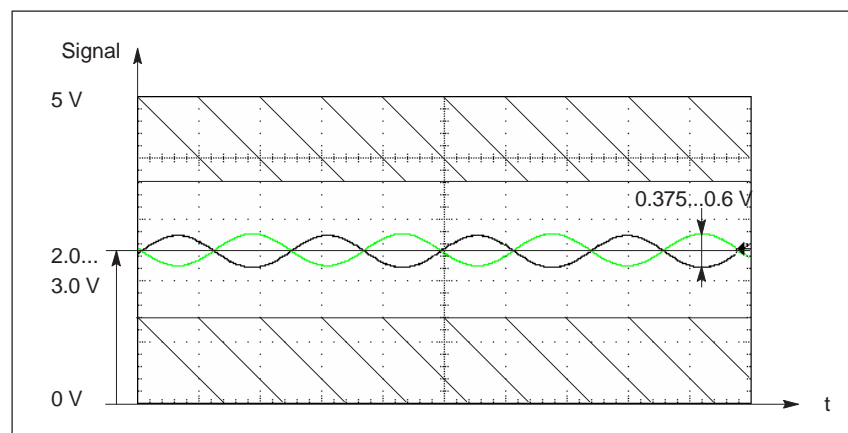

Fig. 3-1 Signal characteristics for track signals A+, A-, B+, B-, C+, C-, D+ and D-

- For zero pulse/reference signal R+ and R–

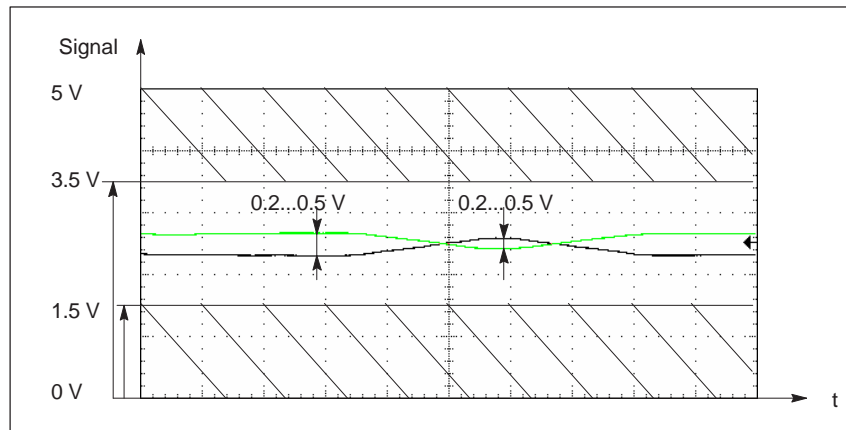

Fig. 3-2 Signal characteristics for zero pulse/reference signal R+ and R–

If other encoder signals are used or in the case of TTL encoders, encoder signal monitoring can be triggered. In particular, the lower signal level for reference signals R+ and R– must be carefully observed.

## Resolver

Key data for resolver as motor encoder:

- Pin assignment: in accordance with Chapter 4.2.2, Table 4-13
- Number of pole **pairs**: 1 or equal to the pole–**pair** count of the motor
- Resolver excitation:  
the control unit produces the voltage with  $4.3 V_{RMS}$  at 9.6 kHz
- Nominal input voltage of the controller:  $\sin/\cos 2.0 V_{RMS}$
- Transmission coefficient of the resolver: approx. 0.46 at 9.6 kHz (often described with 1:2 transformation ratio in the datasheets)
- The resolver excitation is controlled within the control range to provide the input voltage of  $2.0 V_{RMS}$ .
- Maximum excitation current:  $28 mA_{RMS}$  (corresponds to the minimum magnitude of  $154 \Omega$  of the complex input impedance of the resolver)

### Note

The named key data represent starting values for the selection of the resolver but not a complete specification of the resolver interface. In specific cases, the user must check whether the chosen resolver in the complete system meets the requirements.

## 3.2 Motor encoder

**Theoretic resolutions in SIMODRIVE modules**

- Encoder sin/cos 1 Vpp
  - "High Performance" and SIMODRIVE 611 universal control units can be parameterized for encoders up to 65,535 incr./rev. The increment value is increased by the factor 2048 using pulse multiplication in the evaluation of the modules.  
Encoders with 2048 incr./rev. are used in preference. The resolution is then approx. 4.2 million incr./rev. An increment then represents on a 10 mm spindle  $(10 \text{ mm}/(2048 \cdot 2048)) = 2.4 \text{ nm}$ .
  - This means the "High Standard" control unit with a pulse multiplication of 128 with the standard encoder would then be resolved theoretically up to  $(10 \text{ mm}/2048/128) = 38 \text{ nm}$  with the 10 mm spindle.
  - For direct measuring systems (internal pulse multiplication also 2048), an encoder pulse number up to 32 bits can be set.
  - Linear scales can be parameterized with grid divisions from 0 to 8,388,607 nm. Linear encoders with 20  $\mu\text{m}$  grid division are used primarily; the resolution is then  $(20 \mu\text{m}/2048) = 10 \text{ nm}$ .
  - The encoder limit frequency  $f_G$ , with sin/cos 1 Vpp encoders, for "High Performance" and SIMODRIVE 611 universal control units can be as high as 350 kHz, with secondary conditions up to 420 kHz, and max. 200 kHz for "High Standard" control units.
  - With the encoder 2048 incr./rev., with  $350 \text{ kHz} \cdot (60\text{s}/2048)$  up to 10,250 RPM can be processed.
  - The "High Standard" control unit with the standard encoder permits max.  $200 \text{ kHz} \cdot (60\text{s}/2048)$  up to 5,860 RPM.
  - Linear encoders (20  $\mu\text{m}$  grid) permit speeds with  $350 \text{ kHz} \cdot (20 \mu\text{m} \cdot 60\text{s})$  up to 420 m/min.
- Resolver
  - The SIMODRIVE 611 universal control unit in the variant with resolver (1 – 6 pole pairs) permits resolutions with 12– or 14–bit and encoder limit frequencies up to 432 Hz or 108 Hz.
  - For a resolver with 1 pole pair, 12– or 14–bit achieves the resolution 4,096/rev. or 16,384/rev. namely 4,096 incr./rev. or 16,384 incr./rev.
  - The position resolution with 10 mm spindle pitch corresponds theoretically to 2.5  $\mu\text{m}$  or 0.6  $\mu\text{m}$ . The values are correspondingly more favorable for resolvers with a higher number of poles, e.g. for six pole pairs.
  - Maximum speeds can be achieved with 12 bits and for pole pair 1 to  $432 \cdot 60 = 26,000 \text{ RPM}$  and with 14 bits up to approx. 6,500 RPM. Resolvers with a larger number of poles, e.g. six pole pairs, permit only correspondingly lower speeds.

**Note**

Because encoder systems (as result of excitation frequency, excitation amplitudes, windings, non–symmetry of the poles) can exhibit relatively high tolerances in the evaluation for analog/digital conversion, the actually achievable values are significantly lower in practice.

- Encoder with TTL signal

For the speed control of induction motors with SIMODRIVE 611 universal HRS control units, sin/cos 1 Vpp variant, TTL encoders can be connected and evaluated.

The limit frequency  $f_G$  can be as high as 420 kHz.

The SIMODRIVE 611 universal E HRS control unit allows only one TTL signal to be passed to a higher level controller using the PROFIBUS DP.

---

**Note**

The actually achievable system quality with regard to speed or positioning accuracy depends primarily on the quality of the used encoders and other influencing factors, such as:

- the mechanical system (rigidity, backlash, mass ( $GD^2$ )), and also
- the control-engineering configuration of motors, power, controller (interpolation and control cycles, control parameters, etc.)

In practice, the previously mentioned effects mean the quality that can be achieved in a real system is significantly lower than the theoretically achievable quality.

---

## 3.4 Direct position sensing

## 3.3 Indirect position and motor speed sensing

The various possibilities for indirect position and speed sensing and to position the motor shaft as a function of the drive configuration (SINUMERIK, SIMODRIVE and Motor) are shown in Table 3-6 (Chapter 3.5).

## 3.4 Direct position sensing

## 3.4.1 Encoder systems that can be evaluated

The various possibilities for direct position sensing for positioning as a function of the drive configuration (SINUMERIK, SIMODRIVE and Motor) and the encoder system being used are shown in Table 3-7 (Chapter 3.5).

As a result of the higher data transfer reliability, we recommend that sinusoidal voltage signals are used.

**Recommended encoder signals for fault-free operation with sin/cos 1 Vpp**

The following encoder signals are recommended for fault-free operation:

⇒, refer to Chapter 3.2 "Motor encoders"

**Parameterizable encoder limit frequency (as of SW 5.1.14)**

Machine data MD 1326: \$MD\_SAFE\_ENC\_FREQ\_LIMIT can be used to parameterize a limit frequency. The maximum value is 420 kHz, the lower limit and default value is 300 kHz.

**Note**

Changes to this MD may only be made carefully taking into account the prevailing conditions.

This functionality is **only** supported by SIMODRIVE 611 digital High Performance control units.

Table 3-1 Encoder limit frequency and speed

Encoder pulses/ rev.	Speed at the maximum encoder limit frequency		
	200 kHz	300 kHz	420 kHz
2048	5800 RPM	8700 RPM	12300 RPM
1024	11600 RPM	17400 RPM	24600 RPM
512	22200 RPM	34800 RPM	49200 RPM

The following **secondary conditions/limitations** are specified:

1. Cable to be used:  
Siemens cable, Order No.: 6FX2002-2CA31-1CF0
2. Maximum permissible encoder cable length:  
Encoder limit frequency 420 kHz: 20 m
3. Encoder characteristics: "–3dB cut-off frequency" greater than or equal to 500 kHz  
Examples of encoders that can be used:  
ERA 180 with 9000 pulses/rev and ERA 180 with 3600 pulses/rev from the Heidenhain Company.
4. The amplitude monitoring that is active up to 420 kHz.

**Incremental systems with two sinusoidal voltage signals A, B offset by 90 degrees (several, for distance-coded systems) reference mark(s) R.**

Transfer:	Differential signals A, *A; B, *B and R, R*
Amplitude A – *A	1 Vpp + +20% –25%
Amplitude B – *B	1 Vpp + 20% –25%
Amplitude R – *R	0.2 Vpp ... 1 Vpp
Power supply:	5 V ± 5% (also refer to Chapter 3.4.2 Encoder power supply)
Max. power supply current:	300 mA
Max. processable enc. signal frequency:	200 kHz standard module/ 420 kHz (as of SW 5.1.14) <sup>1)</sup> 350 kHz

**Note**

For the above specified max. encoder signal frequency, the signal amplitude must be  $\geq 60\%$  of the nominal amplitude and the deviation of the phase shift from the ideal  $90^\circ$  between track A and B must be  $\leq \pm 30^\circ$ .

Observe the frequency characteristic of the encoder signals.

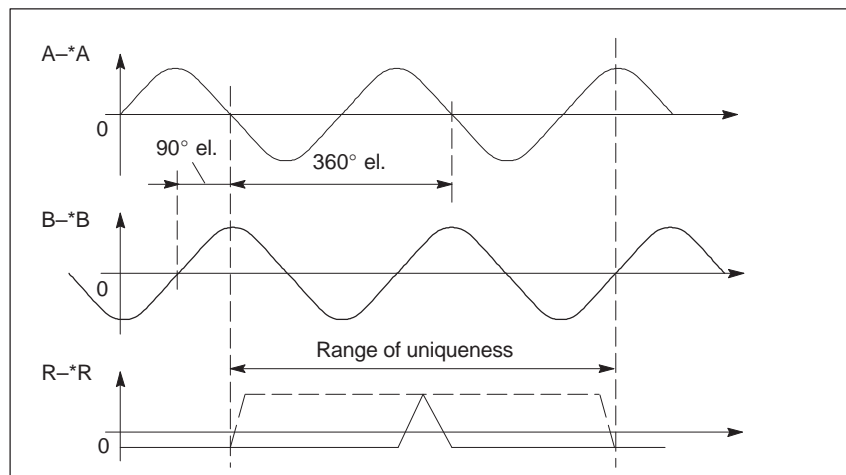

Fig. 3-3 Signal characteristic for a clockwise direction of rotation

1) Refer to parameterizable encoder limit frequency (as of SW 5.1.14)

## 3.4 Direct position sensing

**Singleturn, multiturn and linear absolute systems with two sinusoidal voltage signals A, B offset by 90 degrees and EnDat interface**

Transfer, incremental signals:	Differential signals A, *A and B, *B
Amplitude A – *A	1 Vpp + +20% –25%
Amplitude B – *B	1 Vpp + 20% –25%
Transfer, serial signals:	Differential signals data, *data and clock, *clock
Signal level:	acc. to EIA 485
Power supply:	5 V ± 5% (also refer to Chapter 3.4.2 Encoder power supply)
Max. power supply current:	300 mA
Max. processable enc. signal frequency:	200 kHz standard module/ 420 kHz (as of SW 5.1.14) <sup>1)</sup> 350 kHz

**Note**

For the above specified max. encoder signal frequency, the signal amplitude must be  $\geq 60\%$  of the nominal amplitude and the deviation of the phase shift from the ideal  $90^\circ$  between track A and B must be  $\leq \pm 30^\circ$ .

Observe the frequency characteristic of the encoder signals.

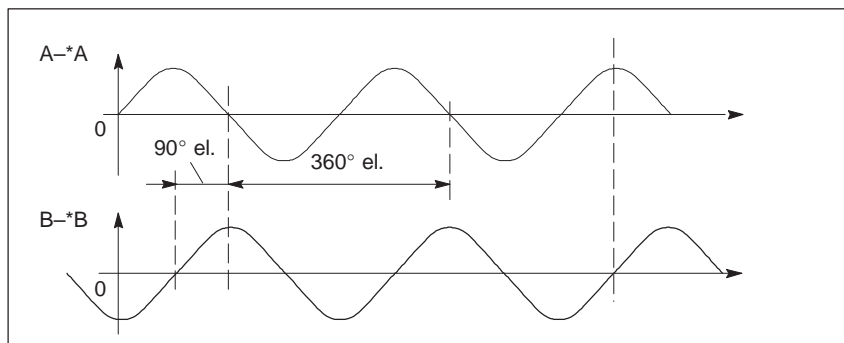

Fig. 3-4 Signal curve of incremental tracks for clockwise rotation

1) Refer to parameterizable encoder limit frequency (as of SW 5.1.14)

**Incremental signals with two square wave signals A, B offset by 90 degrees and reference mark(s) R SIMODRIVE 611 universal HRS/  
SIMODRIVE universal HRS E**

Transfer:	Differential signals A, *A; B, *B and R, *R
Signal level:	According to RS422
Power supply:	5 V $\pm$ 5% (also refer to Chapter 3.4.2 Encoder power supply)
Max. power supply current:	Max. 300 mA
Max. encoder signal frequency that can be evaluated:	420 kHz

**Note**

For the above specified max. encoder signal frequency, the edge clearance between track A and B must be  $\geq 200$  ns.

Observe the frequency characteristic of the encoder signals!

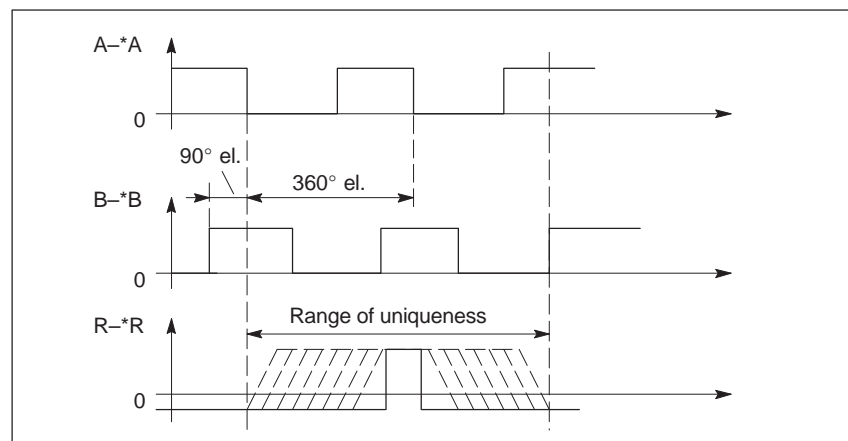

Fig. 3-5 Signal characteristic for a clockwise direction of rotation



### 3.4 Direct position sensing

#### SSI encoder

The SSI encoder is used as direct position measuring system (NC) (SSI scale/encoder is attached to the load). In addition to this direct position measuring system, on the motor side, the speed is sensed using an incremental motor encoder.

The exception is the measuring system sensing for SIMODRIVE 611D HLA, where the linear scale can be used as "motor measuring system".

The used SSI encoders must comply with the following specification:

Gray or binary-coded encoders can be used under the assumption:

- Error bit/alarm bit is the LSB; if, in addition, a parity bit is transferred, then this is the next to last bit. If an alarm bit is not transferred, then the parity bit is the LSB.
- The net (useful) information – also as parity or error bit/alarm bit – are either gray or binary-coded – but never mixed.
- Message frame length (including alarm and/or parity):
  - **SIMODRIVE HLA** 13 and 25 bit,
  - **SIMODRIVE 611D** from 13, to 25 bit
- Data format: **SIMODRIVE HLA** only right justified
- For HLA: The encoder zero point of the linear encoder (absolute value 0) must not be located in the traversing range.
- Transfer frequency, f: 100 or 500 kHz.
- Monoflop time:
  - at 100 kHz  $t_m$  min 12  $\mu$ s,
  - at 500 kHz  $t_m$  min 2.4  $\mu$ s,
  - or  $t_m > 1.2 \cdot 1/f$
- Operation is only possible **without** Safety Integrated!

---

#### Note

Only SSI encoders without incremental tracks may be used. The connection of SSI encoders is not possible on the connection for the indirect measuring system (X411, X412). The use as direct measuring system is possible only for HLA axes.

---

### 3.4.2 Encoder power supply

Remote/sense operation is possible with the encoder power supply for the motor measuring systems and the encoder power supplies for the measuring systems for direct position sensing (voltage controlled directly on the encoder to  $\pm 5\%$ ).

**Remote/sense operation means:**

The power supply voltage of the measuring system is sensed using the sense lines P sense and M sense (quasi zero-current measurement).

The controller compares the measuring system power supply voltage, sensed using the remote sense lines, with the reference power supply voltage of the measuring system and adjusts the power supply voltage for the measuring system at the drive module output until the required power supply voltage is set directly at the measuring system.

This means that the voltage drops across the power supply cables – P encoder and M encoder – are compensated and corrected by the encoder power supply.

The reference voltage is generated from a reference voltage source and is 5 V.

This means that it is possible to use cable lengths up to 50 m without having to operate the measuring systems with an undervoltage condition.

**Note**

All data only apply for SIEMENS pre-assembled cables as these are correctly dimensioned regarding the cable cross-sections.

For SIMODRIVE connection systems and also for the measuring system suppliers, remote/sense operation is only possible for encoder systems with voltage signals.

For motor measuring systems and mounted SIMODRIVE sensor encoders, the sense lines are connected in the encoder or in the connector on the encoder side. For third-party encoder systems, the customers must make the appropriate connections.

**High Performance digital FD and MSD drive control**

Remote/sense operation

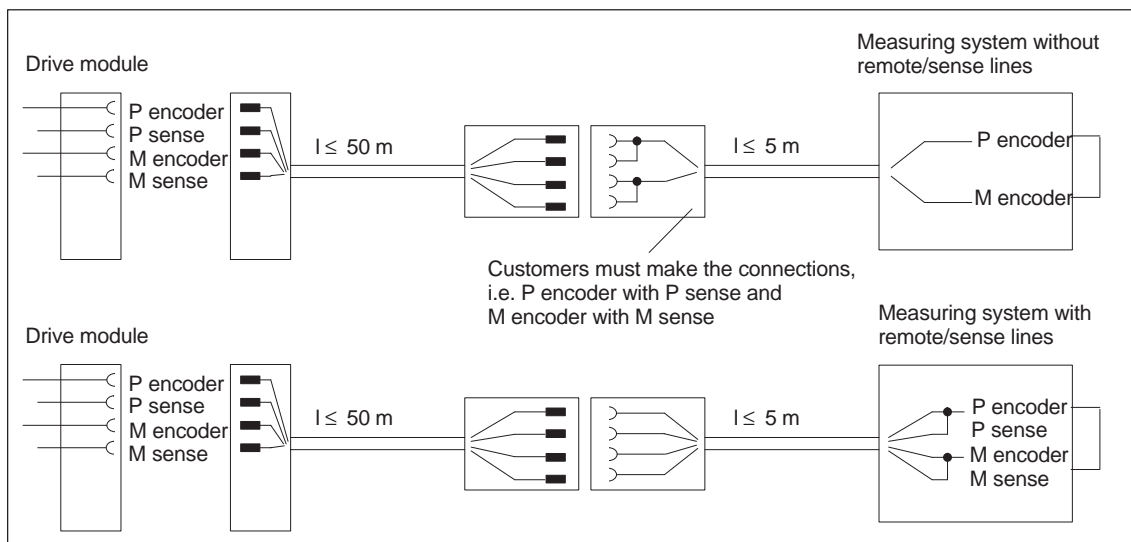

Fig. 3-6 Signal overview of the connections

## 3.4 Direct position sensing

## 3.4.3 Encoder power supply for SSI encoders

**General information**

For SIMODRIVE, an internal 5 V is provided to supply encoders. When using SSI encoders, the power supply voltage must be externally connected to the encoder cable.

**What has to be observed?**

The following must be observed (refer to Fig. 3-7):

**Note**

SSI encoders are likely to have lower noise immunity due to the encoder and the 24 V power supply.

- The encoders must be supplied with a separately regulated 24 V voltage (e.g. SITOP power) in order to avoid disturbances/noise due to contactors, etc.
- The external 24 V power supply must have "safe separation" (PELV).
- Filter data:
  - The special filter is required in order to filter-out noise and disturbances
  - Maximum continuous operating current = 0.8 A (use a fuse!)
  - Max. voltage = 30 V
  - One filter is designed for two encoders with a maximum current = 0.4 A
- The 24 V supply (reference potential) should be connected to the electronics ground of the system (e.g. terminal X131 on the NE module) if this connection is not already provided in the encoder.
- Maximum cable length between the 24 V supply and the filter  $\leq 10$  m
- Maximum encoder cable = 40 m
- The technical data of the encoder manufacturer must be carefully observed.
- Third-party encoders must be connected using the adapter cables provided by the particular manufacturer.

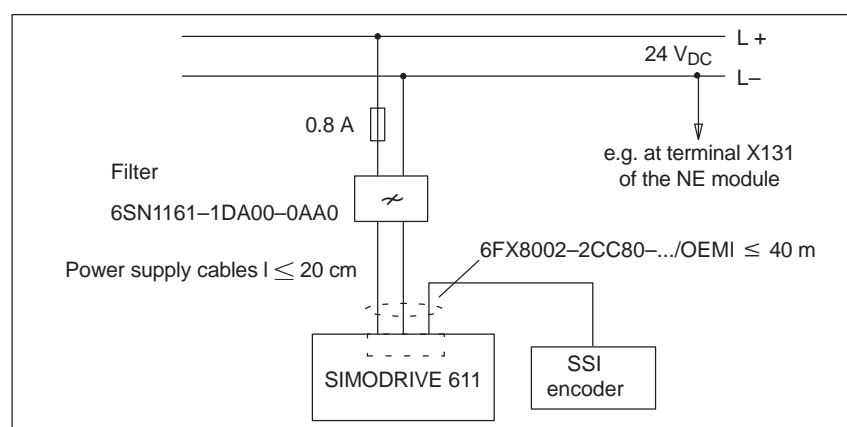

Fig. 3-7 Connecting SSI encoders to SIMODRIVE 611

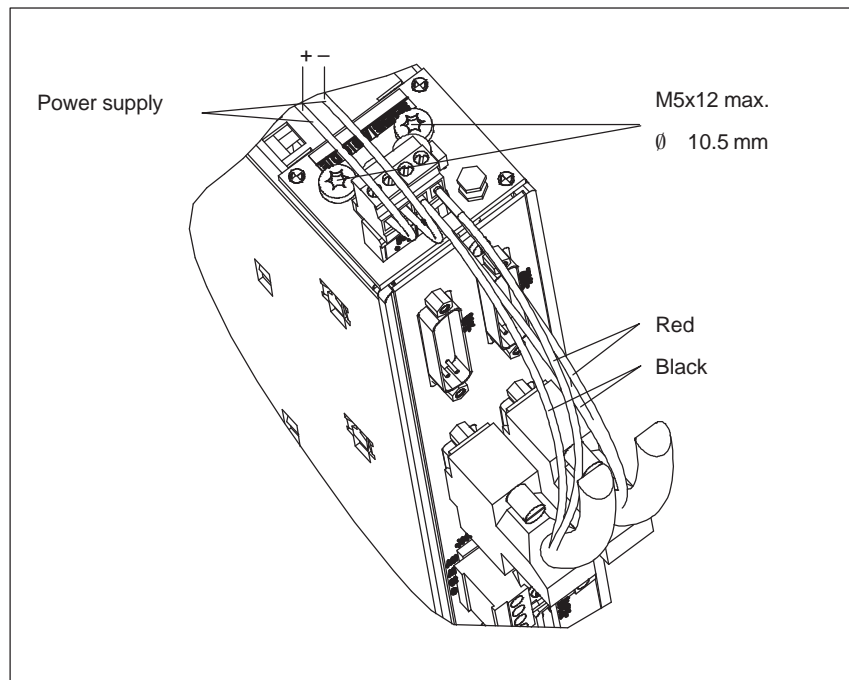

Fig. 3-8 Connection example for the High Performance digital control

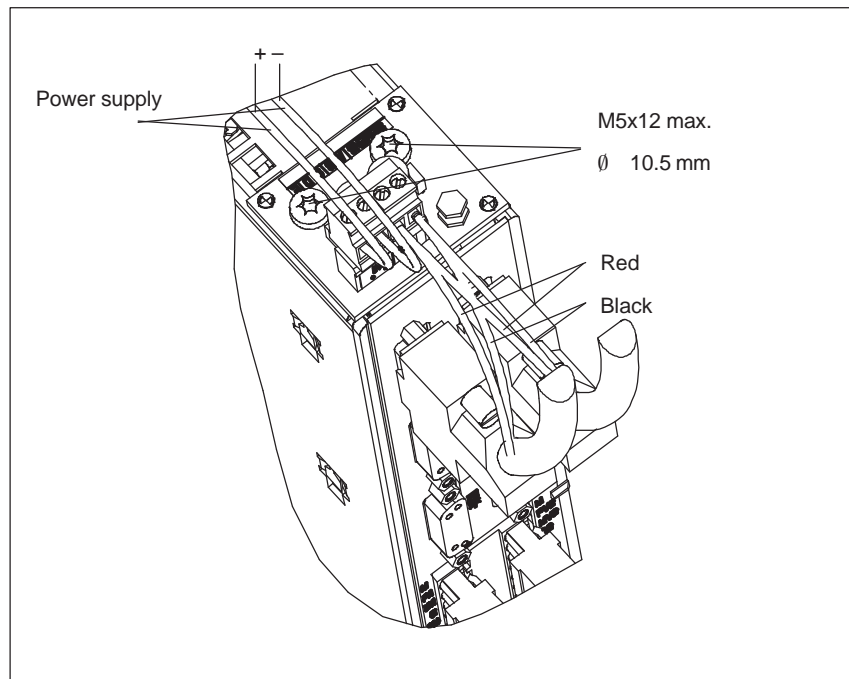

Fig. 3-9 Connection example for the "HLA module" control board

## 3.4 Direct position sensing

## 3.4.4 Signal amplifier electronics

The signal amplifier electronics (SVE) is used for encoders with current signals between the encoder and drive module to convert the current signals into voltage signals 1 V<sub>pp</sub> .

The signal amplifier electronics were developed for optical encoder systems equipped with photodiodes and no additional supplementary electronics (example, ROD 456 from the Heidenhain company). However, there are many encoder systems in the market with integrated electronics where the behavior of current signals is only roughly emulated. As a result of the many options available, a general statement regarding the compatibility between the encoder, SVE and closed-loop control cannot be made.

**Notice**

For new applications, no longer use encoders with current signals, as voltage signals offer a higher noise immunity.

**The signal amplification electronics can be used in conjunction with the following control modules:**

- SIMODRIVE 611 digital High Standard or High Performance
- SIMODRIVE 611 universal HRS/E HRS for encoders with sin/cos 1V<sub>pp</sub>
- HLA module
- ANA module

Table 3-2 Technical data of the signal amplifier electronics

Technical specifications	
Signal shape	Sine/cosine
Input signal	7 μA <sub>PP</sub> to 16 μA <sub>PP</sub>
Output signal	1V <sub>PP</sub>
Max. signal frequency	300 kHz
Max. operating voltage At the remote sense	8 VDC
Max. operating current	200 mA
Encoder voltage supply	5 VDC ± 5%
Max. encoder current supply	120 mA
Dimensions (W x H x D)	54 mm x 121 mm x 57 mm
Order number	6SN1115-0AA12-0AA0
Housing degree of protection	IP65

### SVE pin assignment

- Encoder signal input (for encoders with current signals) at the signal amplification electronics (SVE).

A 9-pin flange-mounted socket with socket contacts for standard round encoder connectors is provided at the SVE.

The input is located on the side with the PE connection.

Table 3-3 Assignment of the SVE signal input

Pin	Signal name	Function
1	AP	Current signal input for incremental track A
2	AN	Inverse current signal input for incremental track A
3	P_ENCODER	Encoder power supply
4	M_ENCODER	Encoder power supply ground
5	BP	Current signal input for incremental track B
6	BN	Inverse current signal input for incremental track B
7	RP	Current signal input for track R (zero mark/reference pulse)
8	RN	Inverse current signal input for track R (zero mark/reference pulse)
9	SHIELD	Ground pin to connect the inner shield

- Output of the SVE (connection to the SIMODRIVE controls, input at the direct measuring system for voltage signals).

A 12-pin flange-mounted socket with plug contacts for standard round encoder connectors is provided at the SVE.

Table 3-4 Assignment of the SVE signal output

Pin	Signal name	Function
1	BN	Inverse voltage signal output for incremental track B
2	PSENSE	Remote Sense encoder power supply (P)
3	RP	Voltage signal input for track R (zero mark/reference pulse)
4	RN	Inverse voltage signal input for track R (zero mark/reference pulse)
5	AP	Voltage signal output for incremental track A
6	AN	Inverse voltage signal output for incremental track A
7	–	not assigned
8	BP	Voltage signal output for incremental track B
9	–	not assigned
10	MENC	Encoder power supply ground
11	MSENSE	Remote Sense encoder power supply (M)
12	PENC	Encoder power supply

3.5 Overview, position sensing

### 3.5 Overview, position sensing

Table 3-5 Assignment, motor measuring systems to control unit

Drive control unit, High Performance (FD mode)						
Drive control unit, High Performance (MSD mode)						
Drive control unit, High Standard (FD mode)						
Drive control unit, High Standard (MSD mode)						
Drive control unit 611 universal HRS resolver						
Drive control unit 611 universal HRS– 1 Vpp voltage signals						
					Motor type	Encoder system
				Yes	1FK Servo motor	Resolver
Yes		Yes		Yes	1FT/1FK Servo motor	Incremental encoder 1 Vpp
Yes		Yes		Yes	1FT/1FK Servo motor	Multiturn absolute encoders
Yes		Yes		Yes	1FN Linear motor	Incremental encoder (Hall sensor box) 1 Vpp Absolute encoder
	Yes		Yes	Yes	1PH4/6/7 Main spindle motor	Incremental encoder 1 Vpp
	Yes		Yes	Yes	1FE1/1PH2/1PM/2SP1 Main spindle motor	Incremental encoder (hollow-shaft encoder) 1 Vpp (toothed wheel or magnetic)
Yes		Yes		Yes	1FW Built-in torque motor	Incremental encoder 1 Vpp Absolute encoder
	Yes		Yes	Yes	1LA standard motor	Encoderless (sensorless)

Table 3-6 Indirect position (motor rotor position) and motor speed sensing digital controls

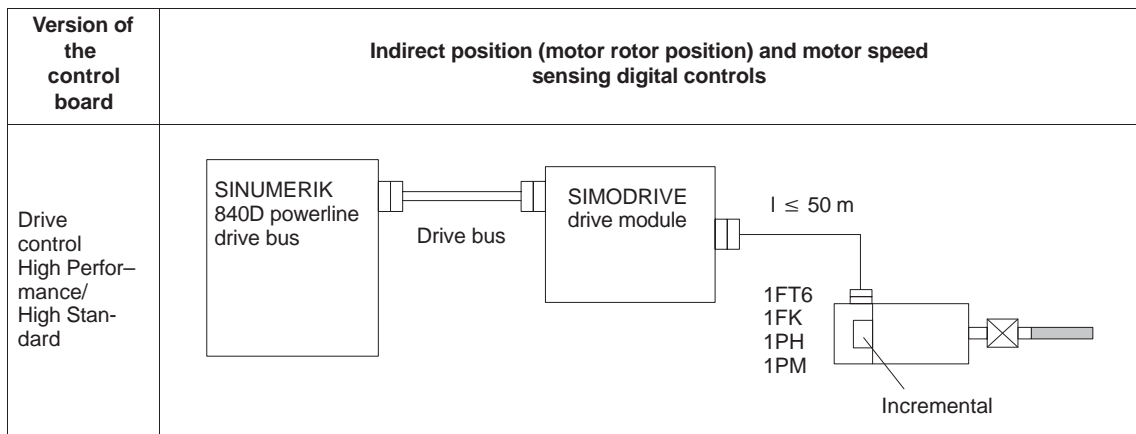
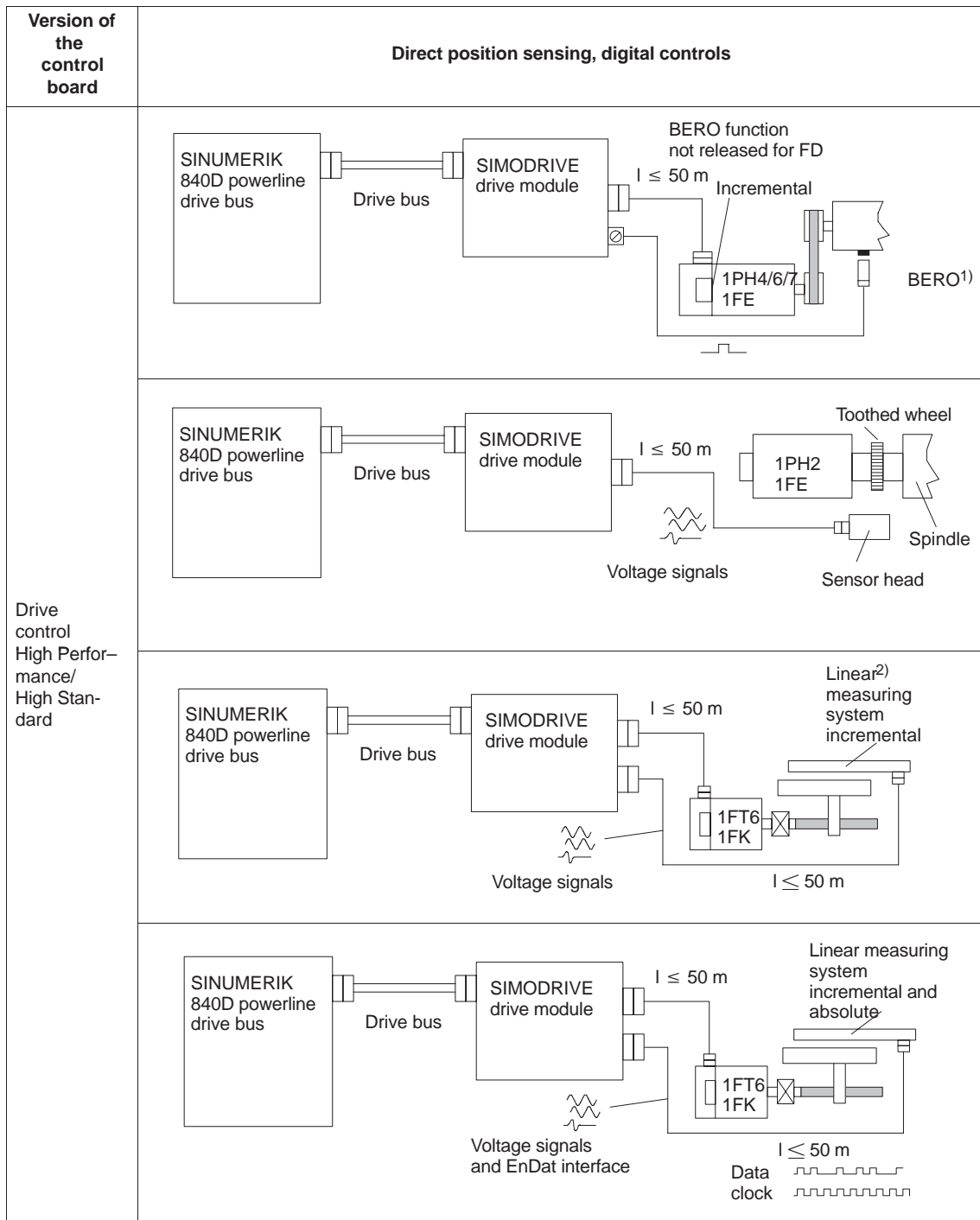

Table 3-7 Direct position sensing, digital control



- 1) The absolute accuracy for so-called synchronization with a BERO depends on the following:
- the switching time of the BERO
  - the hysteresis of the BERO
  - the signal edge gradient (rate-of-rise) of the BERO signal (depending on the direction of rotation) and the switching thresholds in the drive; high > 13 V, low < 5 V
  - the search speed and the signal runtimes in the evaluation electronics

- 2) Distancecoded reference marks can be evaluated



## 3.6 Ordering information

Table 3-7 Direct position sensing, digital control, continued

Version of the control board	Direct position sensing, digital controls
Drive control High Performance/ High Standard	<p>Rotary measuring system, incremental</p> <p>Incremental</p> <p>1PH4/6/7 1FE</p> <p><math>I \leq 50 \text{ m}</math></p> <p>SINUMERIK 840D powerline drive bus</p> <p>Drive bus</p> <p>SIMODRIVE drive module</p>
Drive control High Performance	<p>incremental or incremental + absolute linear scale</p> <p>SLM</p> <p>1FN</p> <p>Hall sensor box</p> <p><math>I \leq 50 \text{ m}</math></p> <p>SINUMERIK 840D powerline drive bus</p> <p>Drive bus</p> <p>SIMODRIVE drive module</p>
Drive control High Performance	<p>1FW</p> <p>Temp</p> <p><math>I \leq 50 \text{ m}</math></p> <p>SINUMERIK 840D powerline drive bus</p> <p>Drive bus</p> <p>SIMODRIVE drive module</p>

## 3.6 Ordering information

Refer to the relevant catalog for the Order Nos. of the specified components

- Pre-assembled encoder cables with the appropriate maximum permissible cable lengths refer to Catalog NC Z
- Toothed-wheel encoder and the diagnostics box required to make adjustments refer to Catalog NC Z or NC 60



## Control Units

### Overview of the control units

The control units/boards listed in the following table can be used in the SIMODRIVE power modules.

Table 4-1 Overview of the control units/boards

Closed-loop control module	Variant	Axes	Motor encoder	Motors <sup>1)</sup>	Optional interfaces
SIMODRIVE 611 universal HRS	1-axis n-set	1	Resolver	SRM: 1FT6, 7 1FK, 1FE1, 1FW6, 2SP1 IM: 1PH, 1PM6, SLM: 1FN Third-party: If suitable	PROFIBUS DP, terminals; RS 232/485
SIMODRIVE 611 universal HRS	1-axis pos.	1	Resolver	SRM: 1FT6, 7 1FK, 1FE1, 1FW6, 2SP1 IM: 1PH, 1PM6, SLM: 1FN	PROFIBUS DP, terminals; RS 232/485
SIMODRIVE 611 universal HRS	2-axis n-set	2	Resolver	SRM: 1FT6, 7 1FK, 1FE1, 1FW6, 2SP1 IM: 1PH, 1PM6, SLM: 1FN Third-party: If suitable	PROFIBUS DP, terminals; RS 232/485
SIMODRIVE 611 universal HRS	2-axis pos	2	Resolver	SRM: 1FT6, 7 1FK, 1FE1, 1FW6, 2SP1 IM: 1PH, 1PM6, SLM: 1FN	PROFIBUS DP, terminals; RS 232/485
SIMODRIVE 611 universal HRS	2-axis n-set	2	Incremental encoder sin/cos 1 V <sub>PP</sub> Absolute encoder	SRM: 1FT6, 7 1FK, 1FE1, 1FW6, 2SP1 IM: 1PH, 1PM6, SLM: 1FN Third-party: If suitable	PROFIBUS DP, terminals; RS 232/485
SIMODRIVE 611 universal HRS	2-axis pos	2	Incremental encoder sin/cos 1 V <sub>PP</sub> Absolute encoder	SRM: 1FT6, 7 1FK, 1FE1, 1FW6, 2SP1 IM: 1PH, 1PM6, SLM: 1FN Third-party: If suitable	PROFIBUS DP, terminals; RS 232/485
SIMODRIVE 611 universal E HRS		2	Incremental encoder sin/cos 1 V <sub>PP</sub> Absolute encoder	SRM: 1FT6, 7 1FK, 1FE1, 1FW6, 2SP1 IM: 1PH, 1PM6, SLM: 1FN Third-party: If suitable	PROFIBUS DP, terminals; RS 232

- 1) SRM: Synchronous rotating motor  
 IM: Induction rotating motor  
 IM: Synchronous linear motor  
 Standard: Standard motor  
 Third-party: Unlisted motor

Table 4-1 Overview of the control units/boards

Closed-loop control module	Variant	Axes	Motor encoder	Motors <sup>1)</sup>	Optional interfaces
SIMODRIVE 611 with digital setpoint interface for FD and MSD	High Perfor- mance control	2	Incremental encoders sin/cos 1 V <sub>PP</sub> , EnDat	SRM: 1FT6, 1FK, 1FE1, 1FW6, 2SP1 IM 1PH, 1PM SLM: 1FN Standard: 1LA Third-party: If suitable	
SIMODRIVE 611 with digital setpoint interface for FD and MSD	High Perfor- mance control	1	Incremental encoders sin/cos 1 V <sub>PP</sub> , EnDat	SRM: 1FT6, 1FK, 1FE1, 1FW6, 2SP1 IM: 1PH7, 1PM SLM: 1FN Standard: 1LA Third-party: If suitable	
SIMODRIVE 611 with digital setpoint interface for FD and MSD	High Standard control	2	Incremental encoders sin/cos 1 V <sub>PP</sub> , EnDat	SRM: 1FT6, 1FK, 1FE1, 2SP1 IM: 1PH7, 1PM6 Standard: 1LA Third-party: If suitable	
SIMODRIVE 611 with digital setpoint interface for hydraulic/analog Linear drives HLA/ANA		2	Incremental encoders sin/cos 1 V <sub>PP</sub> , EnDat, SSI (SW 1.2.4 and higher)	Hydraulic linear axes/ana- log axis	

- 1) SRM: Synchronous rotating motor  
IM: Induction rotating motor  
IM: Synchronous linear motor  
Standard: Standard motor  
Third-party: Unlisted motor

## 4.1 Closed-loop control with digital setpoint interface

### General information

Digital control units in 1-axis and 2-axis versions (for 1PH, 2-axis control is only possible with High Performance) are available to operate motors 1FT6/1FK/1FN1/1FN3/1FE1/1PH/1PM/1FM6/2SP1.

During the initialization phase (power on or reset), the drive software is downloaded from the SINUMERIK 840D to the control board via the drive bus.

### 1-axis drive control

**High Performance: Order No.: 6SN1118-0DJ2□-0AA□**

The digital 1-axis High Performance control can be loaded with the drive software for either FD control or MSD control. MSD and FD have the same user interface. The board is available in the following versions:

- Basic version with sinusoidal **voltage signals** and the possibility of connecting absolute encoders with EnDat interface
- In addition, the evaluation of a direct position measuring system with sinusoidal **voltage signals** and the connection of absolute encoders with EnDat interface and SSI interface (as of SW 5.1.9) is possible.

### 2-axis drive control

The module is available in three basic versions that differ in the controller performance and in the evaluation of the direct position measuring systems:

**High Performance: Order No.: 6SN1118-0DK2□-0AA□**

- Basic version with sinusoidal **voltage signals** and the possibility of connecting absolute encoders with EnDat interface
- In addition, the evaluation of two direct measuring systems with sinusoidal **voltage signals** and the connection of absolute encoders with EnDat interface and SSI interface (as of SW 5.1.9) is possible.

**High Standard: Order No.: 6SN1118-0DM3□-0AA□**

- Basic version with sinusoidal **voltage signals** and the possibility of connecting absolute encoders with EnDat interface.
- Additionally with evaluation for 2 direct measuring systems with sinusoidal **voltage signals** and the possibility of connecting absolute encoders with EnDat interface and SSI interface (from SW 5.1.9).

### Note

A 2-axis drive control can also be operated in a single axis power module for single axis applications. It is engineered as a 1-axis board.

For motor encoders without any adjustment to the EMF of the synchronous motor (1FE1/1FN1/1FN3) a configurable, automatic identification technique can be used to determine the electrical rotor position. In so doing, motion of typically  $< \pm 5$  degrees mechanical is not exceeded. The identification routine is performed after each power up operation.

## 4.1 Closed-loop control with digital setpoint interface

**Software versions** The digital drive controls can be used with the following software releases of the SIEMENS drive components:

Table 4-2 Software functions

	<b>High Performance</b>	<b>High Standard</b>
MLFB	6SN1118-0DJ2□-0AA□ 6SN1118-0DK2□-0AA□	6SN1118-0DM3□-0AA□
NCU version	≥ 6.4.9	≥ 6.4.9
drive version	≥ 6.3.11	≥ 6.5.4
PCU50/PCU20	≥ 6.2.18	≥ 6.2.18
Commissioning tool for the PC	≥ 6.2.18	≥ 6.2.18
NCU hardware	≥ 573.3; ≥ 572.3; 571.3	≥ 573.3; ≥ 572.3; 571.3
Mixed operation, FD/MSD	≥ 6.2.12	≥ 6.2.12

4.1 Closed-loop control with digital setpoint interface

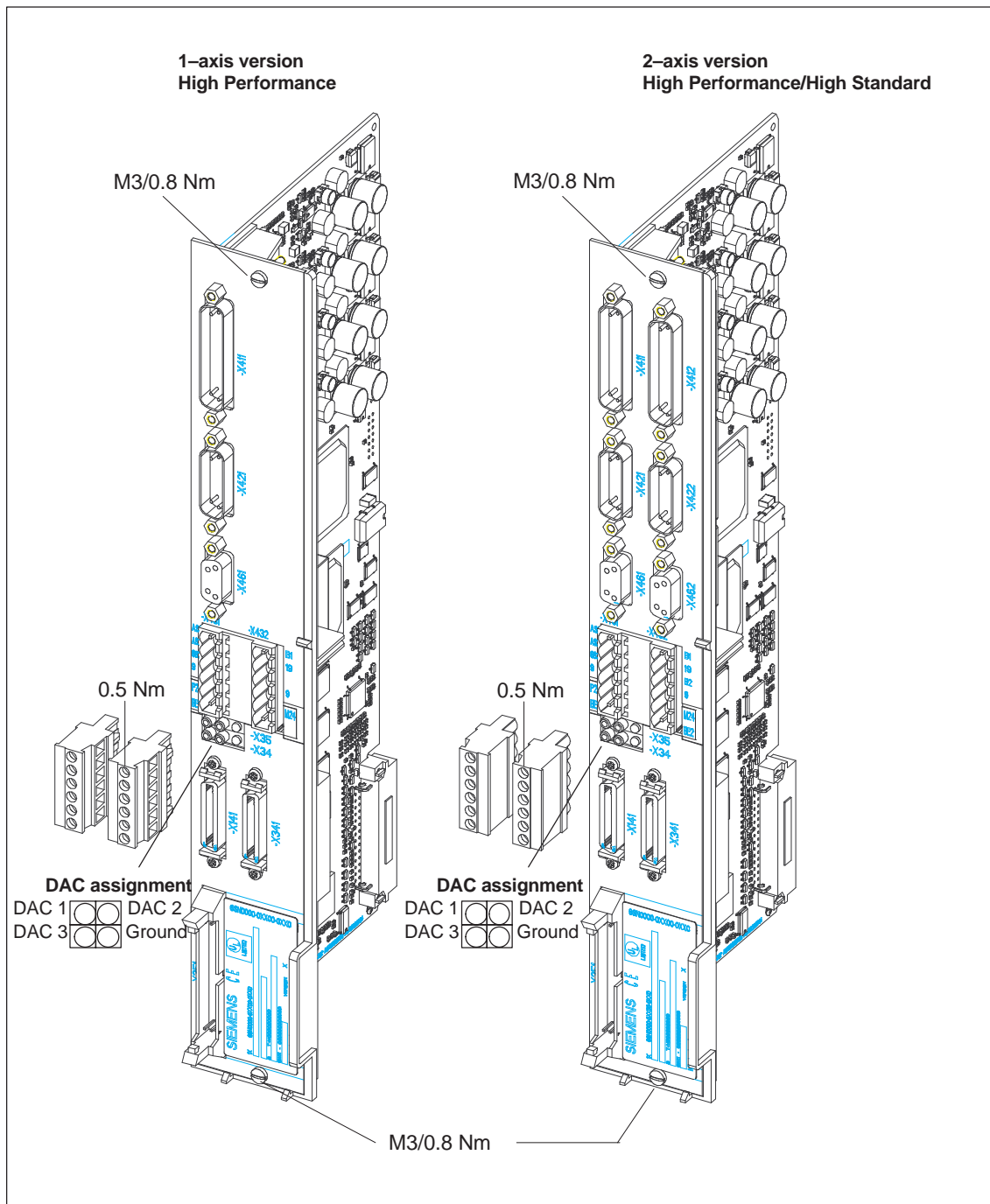

Fig. 4-1 Digital control High Performance and High Standard with direct measuring system

**Notice**

When using non-PELV circuits at terminals AS1, AS2, connectors must be coded to prevent the connectors being incorrectly inserted (refer to EN60204-1, Section 6.4).  
 For Order No. for coded connectors, refer to Catalog NC 60.

4.1 Closed-loop control with digital setpoint interface

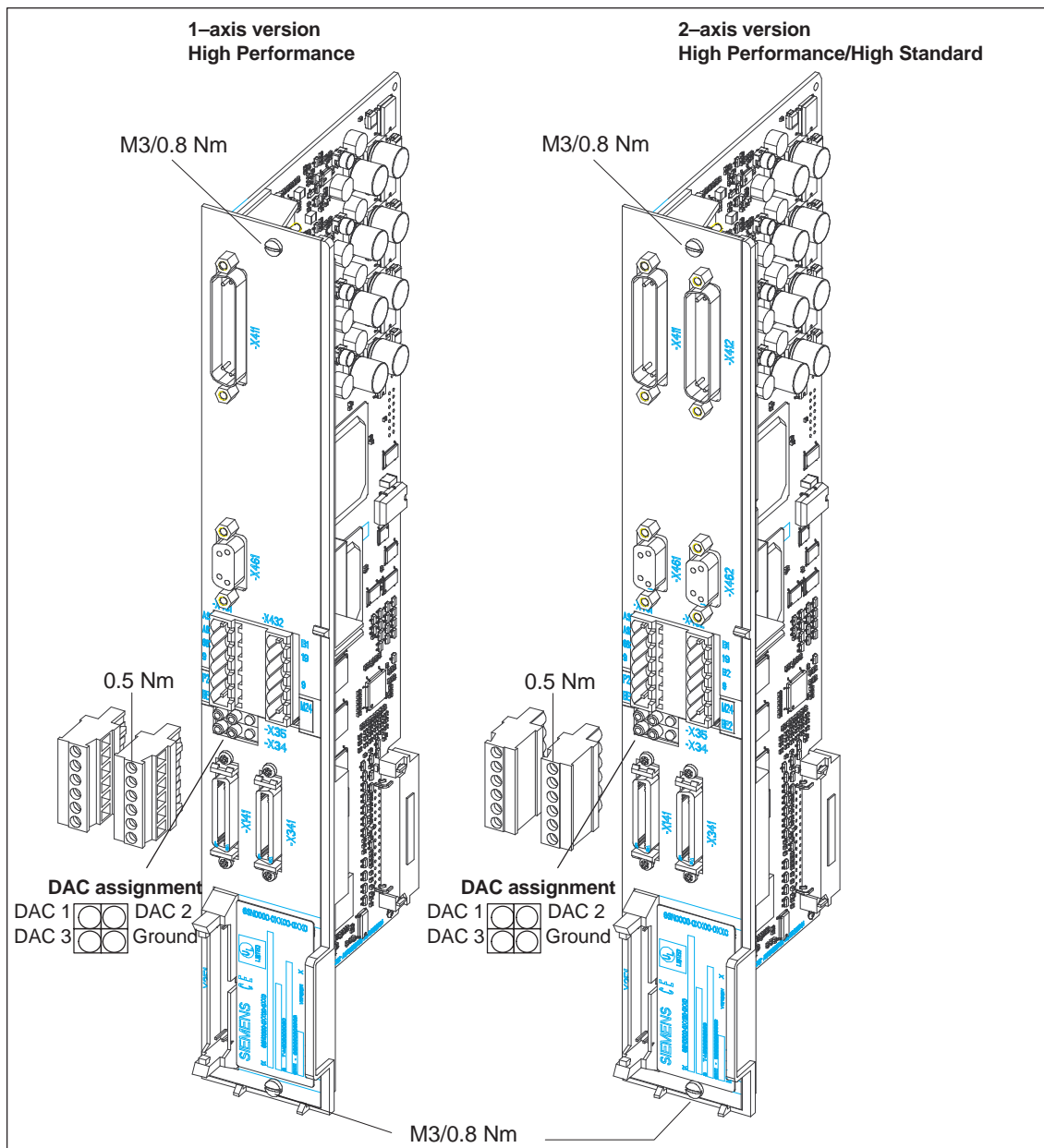

Fig. 4-2 Digital control High Performance and High Standard without direct measuring system

**Notice**

When using non-PELV circuits at terminals AS1, AS2, connectors must be coded to prevent the connectors being incorrectly inserted (refer to EN60204-1, Section 6.4).  
For the order number for coded connectors, refer to Catalog NC 60.



**Warning**

At terminals 19, P24 and M24, only PELV circuits may be connected. If this is not carefully observed, then this can result in personal injury in the form of electric shock.

### 4.1.1 Interface overview, closed-loop drive control

#### High Standard and High Performance

Table 4-3 Interface overview, High Standard and High Performance closed-loop drive control

Term. no.	Designation	Function	Type 1)	Typ. voltage/limit values	Max. cross-section
AS1 <sup>3)</sup>	X431	Relay start inhibit (feedback signal, terminal 663)	NC	max. 250 V AC/1 A, 30 V DC/2 A +21 V ... 30 V	1.5 mm <sup>2</sup>
AS2 <sup>3)</sup>	X431	Relay start inhibit (feedback signal, terminal 663)			1.5 mm <sup>2</sup>
663	X431	Pulse enable: The "starting lockout" relay is operated with terminal 663. On opening, the trigger pulses are inhibited and the motor is switched into a torque-free condition.	I		1.5 mm <sup>2</sup>
9	X431	Enable voltage <sup>2)</sup>	O	+24 V	1.5 mm <sup>2</sup>
P24	X431	+24 V supply for the brake control <sup>4)</sup>	I	+18 ... 30 V	1.5 mm <sup>2</sup>
BE1	X431	Output, brake control, axis 1	O	max. 500 mA	1.5 mm <sup>2</sup>
B1	X432	Input, external zero mark (BERO) axis 1	I	+13 ... 30 V	1.5 mm <sup>2</sup>
19	X432	Negative enable voltage	O	0 V	1.5 mm <sup>2</sup>
B2	X432	Input, external zero mark (BERO) axis 2	I	+13 ... 30 V	1.5 mm <sup>2</sup>
9	X432	Positive enable voltage <sup>2)</sup>	O	+24 V	1.5 mm <sup>2</sup>
M24	X432	0 V supply for the brake control	I		1.5 mm <sup>2</sup>
BE2	X432	Output, brake control, axis 2	O	max. 500 mA	1.5 mm <sup>2</sup>
	X34/X35	Test socket, DAC			
	X411	Motor encoder, axis 1 <sup>5)</sup>		For the terminal assignment, refer to Table 4-4	
	X412	Motor encoder, axis 2 <sup>5)</sup>			
	X421	Direct position encoder, axis 1 <sup>5)</sup>		For the terminal assignment, refer to Table	
	X422	Direct position encoder, axis 2 <sup>5)</sup>			
	X461	BERO input, axis 1		For the terminal assignment, refer to Table 4-6	
	X462	BERO input, axis 2			
	X351	Equipment bus			
	X141/341	Drive bus			

- 1) I=Input; O=Output; NC=NC contact; NO=NO contact (for a signal, NO=High/NC=Low)
- 2) The terminal may only be used to enable the associated drive group.
- 3) When connecting contacts AS1/AS2 in series, a contact voltage drop up to max. 0.2 V must be taken into account for the lifetime of the contacts (100000 switching operations). For a 24 V switching voltage, due to the non-linear contact characteristics, from experience, five contacts can be simply connected in series without encountering any problems.
- 4) A UL-certified miniature fuse (max. 3.15 A) must be provided at the supply for the brake control:  
 Value: e.g. 3.15 AT/250 V; 5x20 mm UL  
 Company: Wickmann-Werke GmbH  
 Annenstraße 113  
 58453 Witte, Germany  
 Order No.: 181
- 5) In order to increase the strength with respect to surge disturbances, for encoder cables > 30 m long, the screen connection 6SN1162-0FA00-0AA2 can be used. In order to ensure noise immunity in compliance with the standard, the encoder cable shields should be connected where the cable enters the control cabinet.  
 The permissible voltage range for the common mode component of the individual encoder signals (A+, A-, B+, B-, C+, C-, D+, D-, R+, R-) is 1.5...3.5 V.
- 6) According to EN 60204-1 (Safety of Machinery) control transformers should be used when using AC control voltages.



## 4.1 Closed-loop control with digital setpoint interface

Encoder  
connection  
X411/X412

Table 4-4 Encoder signal input of motor encoder X411, X412

Pin	X411 (axis 1) X412 (axis 2)	Function
1	PENC	Encoder power supply
2	MENC	Encoder power supply ground
3	AP	Incremental signal for track A
4	AN	Inverse incremental signal for track A
5	M	Inner shield ground
6	BP	Incremental signal for track B
7	BN	Inverse incremental signal for track B
8	M	Inner shield ground
9	–	Reserved, do not use
10	ENDATCLK	EnDat interface clock signal
11	–	Reserved, do not use
12	XENDATCLK	Inverse clock signal, EnDat interface
13	THMOTP	KTY 84 (+) temperature sensor
14	PSENSE	Remote sense encoder power supply (P)
15	ENDATDAT	Data signal EnDat interface
16	MSENSE	Remote sense encoder power supply (N)
17	RP	Reference mark signal/zero pulse
18	RN	Inverse reference mark signal/zero pulse
19	CP	Singleturn absolute track signal C
20	CN	Inverse singleturn absolute track signal C
21	DP	Singleturn absolute track signal D
22	DN	Inverse singleturn absolute track signal D
23	XENDATDAT	Inverse EnDat interface data signal
24	M	Inner shield ground
25	THMOTCOM	KTY 84 (–) temperature sensor
<p><b>Note:</b> The inputs on the control must not be assigned any signals other than the intended signals. Otherwise, sporadic or permanent malfunction or damage can occur. In particular, any existing signals of additional temperature sensors (PTCs, NTCs, etc.) for spindle applications must <b>NOT</b> be applied to the unused CP, CN, DP, or DN inputs when using induction motors!</p>		

## 4.1 Closed-loop control with digital setpoint interface

### Encoder connection X421/X422

Table 4-5 Encoder signal input of direct measuring system X421 . X422

Pin	X421 (axis 1) X422 (axis 2)	Function
1	PENC	Encoder power supply
2	MENC	Encoder power supply ground
3	AP	Incremental signal for track A
4	AN	Inverse incremental signal for track A
5	ENDATDAT	Data signal EnDat interface
6	BP	Incremental signal for track B
7	BN	Inverse incremental signal for track B
8	XENDATDAT	Inverse EnDat interface data signal
9	PSENSE	Remote sense encoder power supply (P)
10	RP	Reference mark signal/zero pulse
11	MSENSE	Remote sense encoder power supply (N)
12	RN	Inverse reference mark signal/zero pulse
13	M	Inner shield ground
14	ENDATCLK	EnDat interface clock signal
15	XENDATCLK	Inverse clock signal, EnDat interface
<p><b>Note:</b> The inputs on the control must not be assigned any signals other than the intended signals. Otherwise, sporadic or permanent malfunction or damage can occur. It is especially important for spindle applications, that possibly available signals from additional temperature sensors (PTCs, NTCs or similar) must NOT be connected to the CP-, CN-, DP-, DN inputs that are not used when using induction motors! When "parking axis" is selected, the encoder can be withdrawn and inserted also under voltage.</p>		

4.1 Closed-loop control with digital setpoint interface

**Holding brake connection**

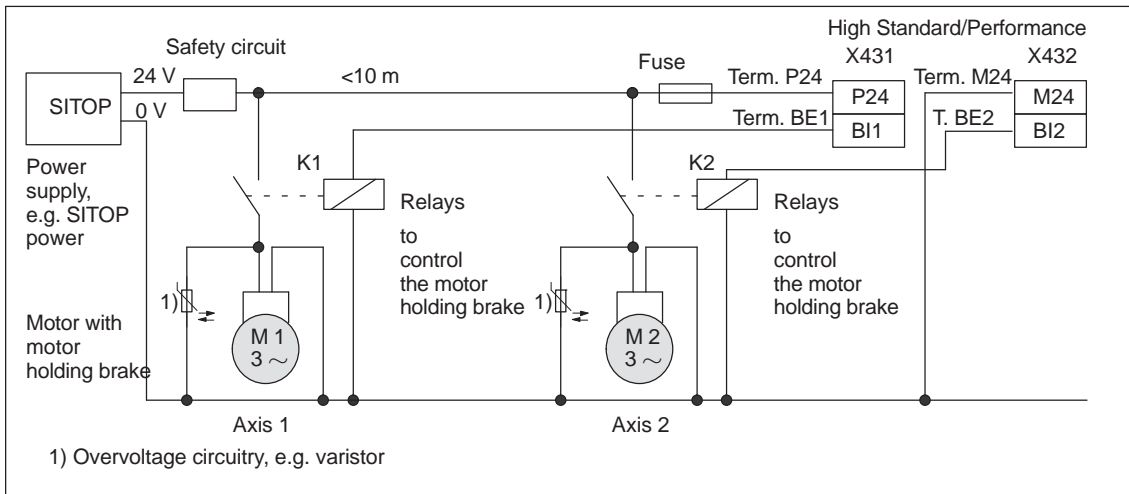

Fig. 4-3 Circuit example: Connecting a motor holding brake to a High Standard/High Performance control board

**BERO input X461/X462**

Table 4-6 BERO input X461/X462

No.	Pin Designation		Function	Type 1)	Technical specifications
	<b>X461</b>	<b>X462</b>	Type: 9-pin D-sub socket connector		
1	FRP	FRP	Internal enable voltage (jumpered with terminal 9)	O	+24 V
2	BERO1	BERO2	BERO input	I	+15 ... 30 V
3	Reserved, do not use	Reserved, do not use		-	
4				-	
5				-	
6	FRM	FRM	Internal enable voltage (jumpered with terminal 19)	O	0 V
7	Reserved, do not use	Reserved, do not use		-	
8				-	
9				-	

1) I: Input; O: Output

## 4.2 "SIMODRIVE 611 universal HRS" control board

### Description

The "SIMODRIVE 611 universal HRS" control board is used in the SIMODRIVE 611 system (SW  $\geq$  8.3) and includes two drive controls that are independent of one another. However, the board can also be used for 1-axis applications and in 1-axis power modules.

### Note

The control board is described in detail in:

**References:** /FBU/ Description of Functions, SIMODRIVE 611 universal

The functionality specified in this Description of Functions under "SIMODRIVE 611 universal" also applies to "SIMODRIVE 611 universal HR".

### Features

The control board has the following features:

- Variants

Table 4-7 Control board, option modules, data medium

Cons. No.	Description		Order No. (MLFB)
	Hardware	Firmware	
Closed-loop control module			
1	2-axis <sup>1)</sup> for encoders with sin/cos 1 Vpp	n-set	6SN1118-0NH01-0AA1
2		Positioning	6SN1118-1NH01-0AA1
4	2-axis <sup>1)</sup> for resolvers	n-set	6SN1118-0NK01-0AA1
6		Positioning	6SN1118-1NK01-0AA1
8	1-axis for resolvers	n-set	6SN1118-0NJ01-0AA1
10		Positioning	6SN1118-1NJ01-0AA1
Option module (can be alternatively used in the control board)			
1	TERMINALS	–	6SN1114-0NA00-0AA0
3	PROFIBUS DP2 <sup>3)</sup>	–	6SN1114-0NB00-0AA2
4	PROFIBUS-DP3 <sup>3)</sup>	–	6SN1114-0NB01-0AA1
Data volume			
1	CD	SimoCom U, drive firmware, Toolbox, GSD file, readme file, etc.	6SN1153-□NX20-□AG0 <sup>2)</sup> □ = 0 → CD with the most current SW version The CD also contains previous SW versions

1) For 2-axis control boards, 1-axis operation is also possible

2) □: Space retainer for software version

3) Prerequisite: Control board as of SW 3.1

## 4.2 "SIMODRIVE 611 universal HRS" control board

- Settings

All drive-related settings of the control board can be made as follows:

- Using the SimoCom U parameterizing and startup tool on an external PG/PC
- Using the display and operator control unit on the front panel
- Using PROFIBUS DP (parameter area, PKW area)

- Software and data

The firmware and the user data are saved on a memory module which can be replaced.

The software designation on the memory module refers to the system software including the initial program loader.

- Terminals and operator control elements

- 2 analog inputs, 2 analog outputs per drive
- 4 digital inputs, 4 digital outputs per drive
- 2 measuring sockets
- POWER-ON RESET pushbutton with LED
- Display and operator unit

- Safe start inhibit

The start inhibit is addressed via terminal 663 and is signaled back using a relay with positively-driven signaling contacts (AS1/AS2). Using the start inhibit, the energy feed from the drive to the motor is interrupted.

When the "safe start inhibit" function is correctly used, the signaling contacts AS1/AS2 must be included in the line contactor circuit or the EMERGENCY OFF circuit.

---

### Caution

When using the "safe start inhibit" function, it must be ensured that the velocity goes to zero.

---

The "SIMODRIVE 611 universal HRS" control board supports the "Safe standstill" function.

Detailed information about the "safe standstill" function is provided in Chapter 8.5.

- Serial interface (RS232/RS485)

- Option modules

- Optional TERMINAL module, 8 digital inputs and 8 digital outputs for drive A
- Optional PROFIBUS-DP module

- Expanded functions as of SW 5.1

The following expanded functionality is provided with a new control board for sin/cos 1Vpp encoders:

- Higher internal resolution, interpolation factor 2048 (previously 128)
- Pulse multiplication is possible (doubling) at the angular incremental encoder interface for absolute encoders
- Pulse multiplication (doubling) and division (1:2, 1:4, 1:8) are possible at the angular incremental encoder interface, also for incremental encoders

### 4.2.1 Control board for 1 or 2 axes

#### Control boards for 2 axes

The following 2-axis control boards are available:

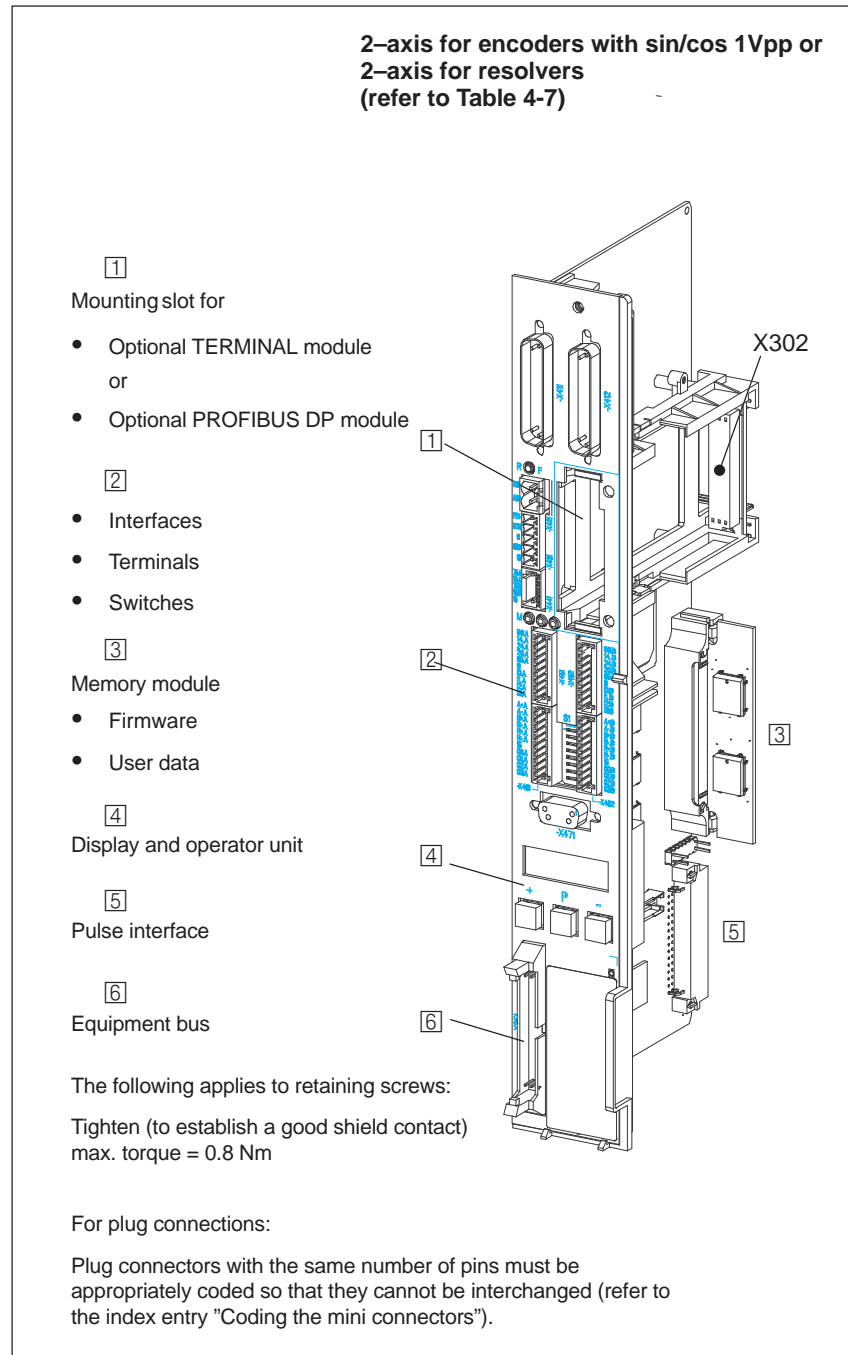

Fig. 4-4 Control boards for 2 axes (SIMODRIVE 611 universal HRS)

4.2 "SIMODRIVE 611 universal HRS" control board

**Control board for 1 axis**

The following 1-axis control boards are available:

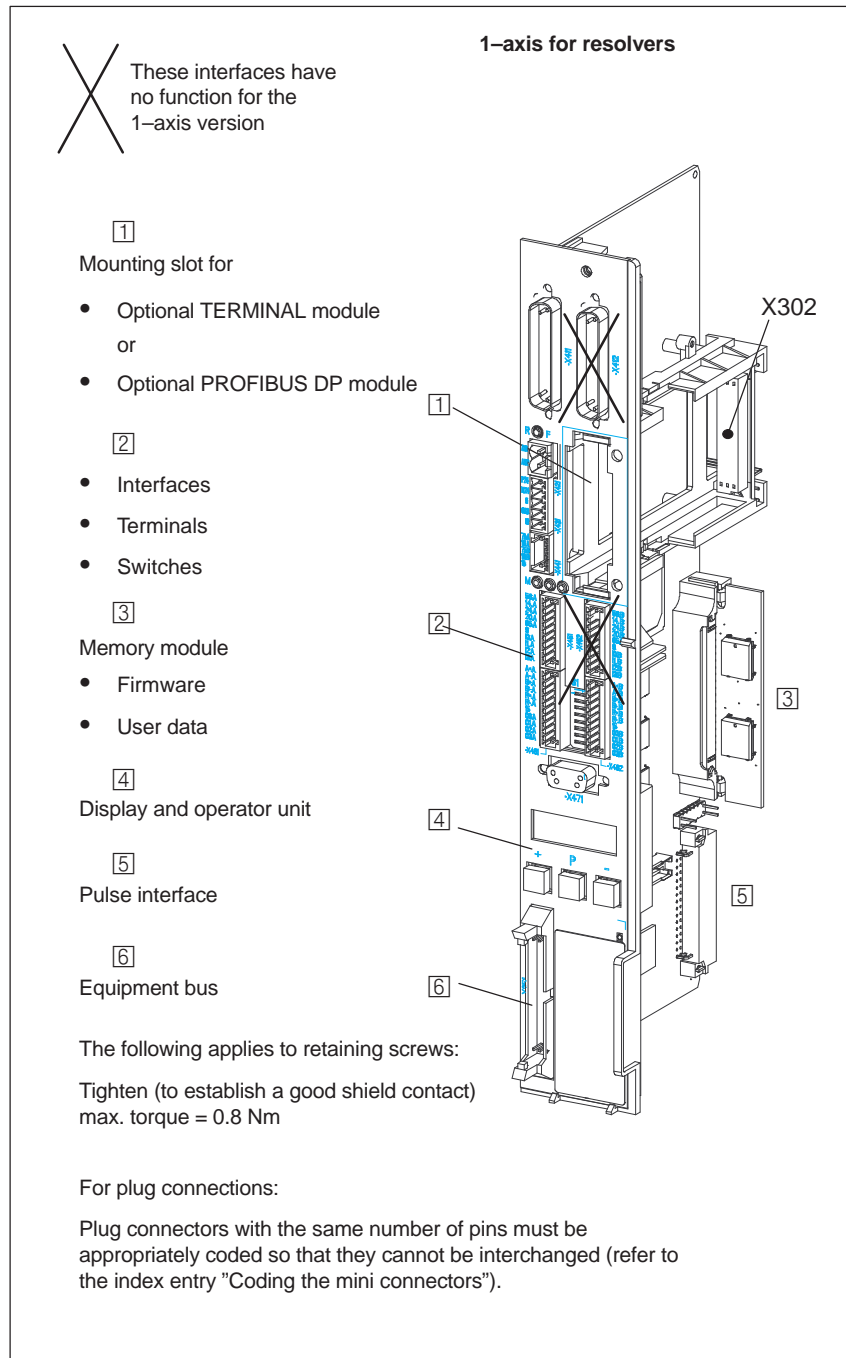

Fig. 4-5 Control board for 1 axis (SIMODRIVE 611 universal HRS)

### Optional terminal module

An additional 8 digital inputs and outputs can be realized using this optional module.

The functionality of these inputs/outputs can be freely parameterized.

#### Note

- The input/output terminals of the optional TERMINAL module are
  - **Before SW 4.1: permanently assigned to drive A or axis A**
  - **As of SW 4.1: can be freely assigned axes**
- The optional TERMINAL module can be used as follows, dependent on the software release:
  - The following applies before SW 2.4:  
The module can only be used in the "positioning" mode.
  - The following applies as of SW 2.4:  
The module can be used independently of the operating mode.

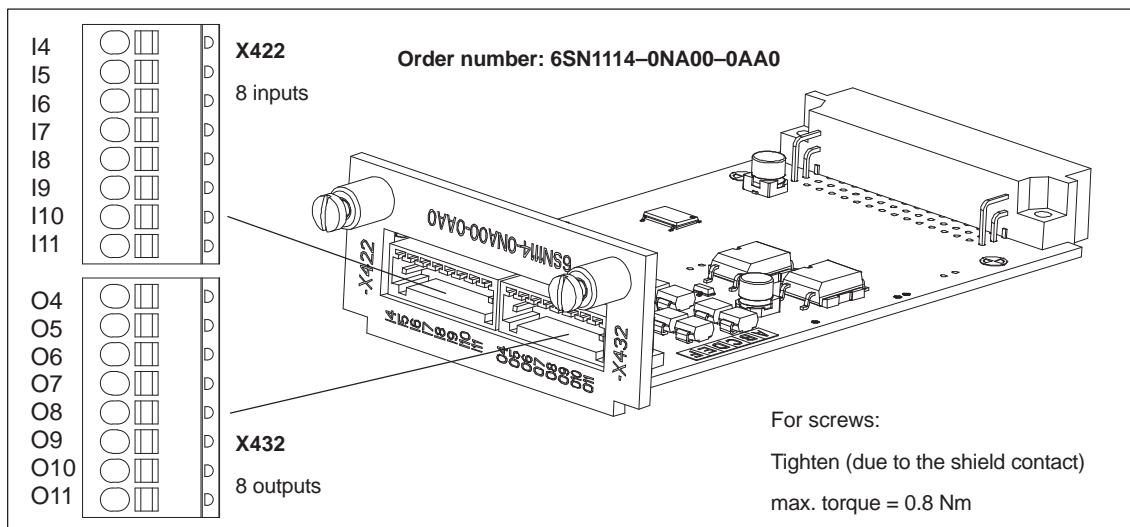

Fig. 4-6 Optional TERMINAL module



4.2 "SIMODRIVE 611 universal HRS" control board

**Optional PROFIBUS DP module**

The "SIMODRIVE 611 universal" control board can be connected and operated as DP slave on the PROFIBUS DP fieldbus when this optional module is used.

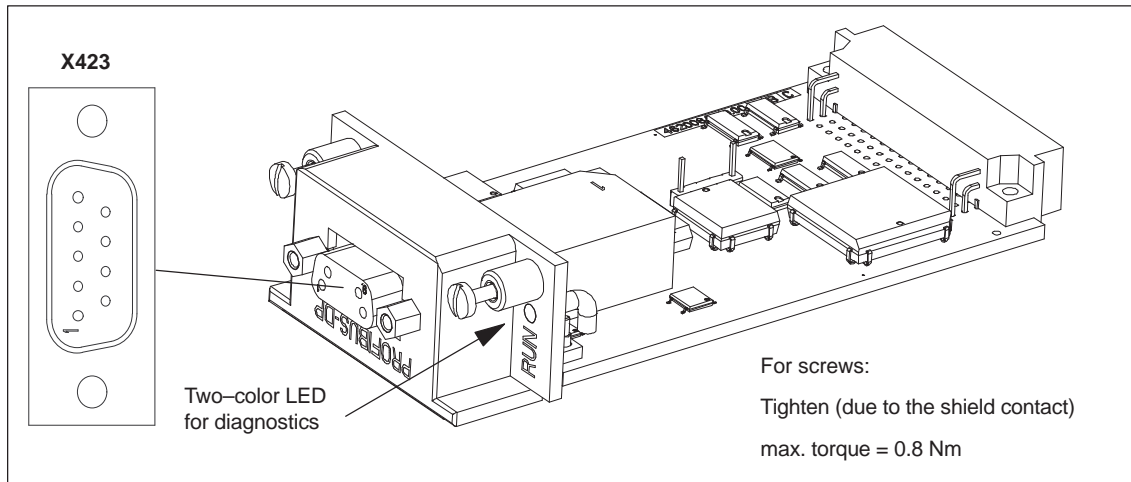

Fig. 4-7 Optional PROFIBUS DP module

Table 4-8 Which optional modules are available?

Designation	Order No. (MLFB)	Properties
PROFIBUS DP2	6SN1114-0NB00-0AA2	<ul style="list-style-type: none"> <li>PROFIBUS ASIC DPC31 without PLL</li> <li>For control boards as of SW 3.1, this module can replace the optional PROFIBUS DP1 module</li> </ul>
Features that PROFIBUS DP2 and DP3 have in common		<ul style="list-style-type: none"> <li>Requirement: Control board as of SW 3.1 is required</li> <li>Cyclic data transfer (PKW and PZD section) possible</li> <li>FW module can be updated using SimoCom U</li> <li>Non-cyclic data transfer (DP/V1)</li> <li>"SimoCom U via PROFIBUS" possible</li> </ul>
PROFIBUS DP3	6SN1114-0NB01-0AA1	<ul style="list-style-type: none"> <li>PROFIBUS ASIC DPC31 with PLL</li> <li>"Motion Control with PROFIBUS DP" function (clock-synchronous PROFIBUS operation) is possible</li> </ul>

Table 4-9 Which optional modules can be used for the various software releases?

Case	Firmware version	Optional module	
		DP2	DP3
1. A master configured software, generated with GSD file siem808f.gsd, can be operated with	as of SW 3.1	Yes	Yes
2. A master configured software, generated with a GSD file siem8055f.gsd and P0875 = 2, can be operated with	before SW 4.1	Yes	Yes
3. A master configured software, generated with a GSD file siem8055f.gsd and P0875 = 2, can be operated with	as of SW 4.1	Yes	Yes
4. Master configured application, generated with a GSD file si02808f.gsd and P0875 = 2 can be operated with	as of SW 6.1	Yes	Yes

**Note**

Case 1 is for "new" applications with the DP2, DP3 module.

Cases 2 and 3 are for series commissioning of drives using DP1 modules and for replacing a defective DP1 module by a DP2 module.

4.2 "SIMODRIVE 611 universal HRS" control board

4.2.2 Description of the terminals and interfaces

**Board-specific terminals and interfaces**

The board-specific terminals and interfaces are available jointly for drive A and B of a 2-axis module.

Table 4-10 Overview of the board-specific terminals and interfaces

Terminal No.	Designation	Function	Type 1)	Technical specifications									
<b>Signaling terminal, start inhibit (X421)</b>													
AS1 <sup>3)</sup>	X421	Signaling contact Start inhibit Feedback signal from terminal 663	NC	Connector type: 2-pin conn. strip Max. cond. cross-sect.: 2.5 mm <sup>2</sup> Contact: Floating NC contact at 250 V <sub>AC</sub> max. 1 A <sup>4)</sup> Contact load capability: at 30 V <sub>DC</sub> max. 2 A									
AS2 <sup>3)</sup>													
		Pulses not enabled (T. 663) The gating pulses of the power transistors are inhibited.		Pulses enabled (T. 663) The gating pulses of the power transistors are enabled.									
<b>Terminals for supply and pulse enable (X431)</b>													
	X431			Connector type: 5-pin conn. strip Max. cond. cross-sect.: 1.5 mm <sup>2</sup>									
P24	X431.1	External supply for digital outputs (+24 V)	S	Voltage tolerance (including ripple): 20,4 V to 28,8 V									
M24	X431.2	Reference for the external supply	S										
<p>The external supply is required for the following digital outputs:</p> <ul style="list-style-type: none"> <li>• 8 outputs of the drive-specific terminals (X461, O0.A – O3.A/X462, O0.B – O3.B)</li> <li>• 8 outputs of the optional TERMINAL module (X432, O4 – O11)</li> </ul> <p>When dimensioning the external power supply, the total current of all of the digital outputs must be taken into account. Maximum total current:</p> <ul style="list-style-type: none"> <li>• for the control board (all 8 outputs): 2.4 A</li> <li>• for the optional TERMINAL module (all 8 outputs): Max. 480 mA</li> </ul> <p><b>Example:</b></p> <table border="0"> <tr> <td>Board/module</td> <td>Outputs</td> <td>Dimensioning the external supply</td> </tr> <tr> <td>Control board</td> <td>8</td> <td>max. 1.5 A → 24 V/1.5 A</td> </tr> <tr> <td>Control module + optional TERMINAL module 8 + 8</td> <td></td> <td>max. (1.5 A + 280 mA) → 24 V/1.8 A</td> </tr> </table>					Board/module	Outputs	Dimensioning the external supply	Control board	8	max. 1.5 A → 24 V/1.5 A	Control module + optional TERMINAL module 8 + 8		max. (1.5 A + 280 mA) → 24 V/1.8 A
Board/module	Outputs	Dimensioning the external supply											
Control board	8	max. 1.5 A → 24 V/1.5 A											
Control module + optional TERMINAL module 8 + 8		max. (1.5 A + 280 mA) → 24 V/1.8 A											

## 4.2 "SIMODRIVE 611 universal HRS" control board

Table 4-10 Overview of the board-specific terminals and interfaces, continued

Terminal		Function	Type 1)	Technical specifications	
No.	Designation				
9	X431.3	Enable voltage (+24 V)	S	Reference: Maximum current(for the total group): <b>Note:</b> The enable voltage (terminal 9) can be used to supply the enable signals (e.g. pulse enable) as 24 V auxiliary voltage.	Terminal 19 Max. 500 mA
663	X431.4	Pulse enable (+24 V)	I	Voltage tolerance(including ripple): Typ. current consumption: <b>Note:</b> The pulse enable acts simultaneously on drive A and drive B. When this pulse enable is withdrawn, the drives "coast down" unbraked.	21 V to 30 V 50 mA at 24 V
19	X431.5	Reference (Reference for all digital inputs)	S	<b>Note:</b> If the enable signals are to be controlled from an external voltage source, the reference potential (ground) of the external source must be connected to this terminal.	
<b>Serial interface (X471)</b>					
–	X471	Serial interface for "SimoCom U"	IO	Type: 9-pin D-sub socket connector Cable diagram and pin assignment for RS232 or RS485, refer to: <b>Reference:</b> /FB611U/ Description of Functions, SIMODRIVE 611 universal	
<b>Equipment bus (X34)</b>					
–	X351	Equipment bus	IO	Ribbon cable: Voltages: Signals:	34-pin various various
<b>Test sockets (X34)</b>					
DAC1	X34	Test socket 1 <sup>2)</sup>	M	Test socket: Resolution: Rated operating voltage: Maximum current:	∅ 2 mm 8 bits 0 V to 5 V Max. 3 mA
DAC2		Test socket 2 <sup>2)</sup>	M		
M		Reference	M		

1) I: Input; IO: Input/output; M: Measuring signal; NC: NC contact; S: Supply

2) Can be freely parameterized

3) When connecting contacts AS1/AS2 in series, a contact voltage drop up to max. 0.2 V must be taken into account for the lifetime of the contacts (100000 switching operations). For a 24 V switching voltage, due to the non-linear contact characteristics, from experience, five contacts can be simply connected in series without encountering any problems.

4) In accordance with EN 60204-1 (machine safety) control-power transformers should be provided when AC control voltages are used.

## 4.2 "SIMODRIVE 611 universal HRS" control board

**Drive-specific terminals**

The drive-specific terminals are available for both drive A and drive B.

Table 4-11 Overview of the drive-specific terminals

Terminal				Function	Type 1)	Technical specifications
Drive A		Drive B				
No.	Designation	No.	Designation			
<b>Encoder connection (X411, X412)<sup>5)</sup></b>						
–	X411	–	–	Motor encoder connection Drive A	I	See Chapter 3 Type: 25-pin D-sub plug connector <b>Note:</b> Encoder limit frequencies: <ul style="list-style-type: none"> <li>Encoder with sin/cos 1 V<sub>pp</sub>: 350 kHz</li> <li>Resolver: 12 bits 432 Hz 14 bits 108 Hz</li> <li>Enc. with TTL signal: 420 kHz</li> </ul> For the encoder connection, refer to Tables 4-12 and 4-13
–	–	–	X412	Motor encoder connection Drive B or connection, direct measuring system (as of SW 3.3)	I	
<b>Analog outputs (X441)</b>						
75.A	X441.1	–	–	Analog output 1 <sup>2)</sup>	AO	Connector type: 5-pin conn. strip Wiring: Connect the cable with the braided shield at both ends Max. cond. cross-section for finely-stranded or solid cond.: 0.5 mm <sup>2</sup> Rated operating voltage: –10 V to +10 V Maximum current: 3 mA Resolution: 8 bits Update: In the speed-contr. clock cycle short-circuit proof
16.A	X441.2	–	–	Analog output 2 <sup>2)</sup>	AO	
–	–	75.B	X441.3	Analog output 1 <sup>2)</sup>	AO	
–	–	16.B	X441.4	Analog output 2 <sup>2)</sup>	AO	
15	X441.5	15	X441.5	Reference	–	
<b>Terminals for analog inputs and digital inputs/outputs (X451, X452)</b>						
	X451		X452	Connector type: 10-pin conn. strip Max. cond. cross-section for finely-stranded or solid cond.: 0.5 mm <sup>2</sup>		
56.A	X451.1	56.B	X452.1	Analog input 1	AI	Differential input Rated operating voltage: –12.5 V to +12.5 V Input resistance: 100 kΩ Resolution: 14 bits (sign + 13 bits) Wiring: Connect the cable to the braided shield at both ends
14.A	X451.2	14.B	X452.2	Reference		
24.A	X451.3	24.B	X452.3	Analog input 2		
20.A	X451.4	20.B	X452.4	Reference		
65.A	X451.5	65.B	X452.5	Controller enable Drive-specific	I	Typ. current consumption: 6 mA at 24 V Signal level (incl. ripple) High signal level: 15 V to 30 V Low signal level: –3 V to 5 V Galvanic isolation: Ref. is T. 19/ T. M24
9	X451.6	9	X452.6	Enable voltage (+24 V)	S	Reference: Terminal 19 Maximum current (for the total group): 500 mA <b>Note:</b> The enable voltage (terminal 9) can be used to supply the enable signals (e.g. controller enable).

## 4.2 "SIMODRIVE 611 universal HRS" control board

Table 4-11 Overview of the drive-specific terminals, continued

Terminal				Function	Type 1)	Technical specifications
Drive A		Drive B				
No.	Designation	No.	Designation			
I0.A	X451.7	I0.B	X452.7	Digital input 0 <sup>2)</sup> Fast input <sup>3)</sup> e.g. for equivalent zero mark, external block change	DI	Voltage: 24 V Typ. current consumption: 6 mA at 24 V Signal level (incl. ripple) High signal level: 15 V to 30 V Low signal level: -3 V to 5 V sampling time, fast input: 62.5 μs Galvanic isolation: Ref. is T. 19/T. M24 <b>Note:</b> An open-circuit input is interpreted as 0 signal.
I1.A	X451.8	I1.B	X452.8	Digital input 1 <sup>2)</sup> Fast input	DI	
I2.A	X451.9	I2.B	X452.9	Digital input 2 <sup>2)</sup>	DI	
I3.A	X451.10	I3.B	X452.10	Digital input 3 <sup>2)</sup>	DI	
<b>Drive-specific terminals (X461, X462)</b>						
	X461		X462	Connector type: 10-pin conn. strip Max. cond. cross-section for finely-stranded or solid cond.: 0.5 mm <sup>2</sup>		
A+.A	X461.1	A+.B	X462.1	Signal A+	IO	Incremental Shaft Encoder Interface (AIE int.) Wiring: <ul style="list-style-type: none"> <li>• Cable with braided shield, connected at both ends.</li> <li>• The reference ground of the connected node should be connected to terminal X441.5 or X461.7.</li> <li>• Condition to maintain the surge strength: Cable length &lt; 30 m</li> </ul>
A-.A	X461.2	A-.B	X462.2	Signal A-	IO	
B+.A	X461.3	B+.B	X462.3	Signal B+	IO	
B-.A	X461.4	B-.B	X462.4	Signal B-	IO	
R+.A	X461.5	R+.B	X462.5	Signal R+	IO	
R-.A	X461.6	R-.B	X462.6	Signal R-	IO	
15	X461.7	15	X462.7	Ground reference	-	
	<b>Note:</b> Devices (stations) can be connected which conform to the RS485/RS422 standard. The angular incremental encoder interface can either be parameterized as an input or output. <ul style="list-style-type: none"> <li>• Input To enter incremental position reference values</li> <li>• Output To output incremental actual position values</li> </ul>					
O0.A	X461.8	O0.B	X461.8	Digital output 0 <sup>4)</sup>	DO	Rated current per output: 500 mA Maximum current per output: 600 mA Maximum total current: 2.4 A (valid for these eight outputs) Voltage drop, typical: 250 mV at 500 mA short-circuit proof <b>Example:</b> If all eight outputs are simultaneously controlled, then the following is valid: $\Sigma$ Current = 240 mA → OK $\Sigma$ Current = 2.8 A → not OK, as the total current is greater than 2.4 A.
O1.A	X461.9	O1.B	X461.9	Digital output 1 <sup>4)</sup>	DO	
O2.A	X461.10	O2.B	X461.10	Digital output 2 <sup>4)</sup>	DO	
O3.A	X461.11	O3.B	X461.11	Digital output 3 <sup>4)</sup>	DO	
<b>Note:</b> <ul style="list-style-type: none"> <li>• The power switched via these outputs is supplied via terminals P24/M24 (X431). This must be taken into account when dimensioning the external supply.</li> <li>• The digital outputs only "function" if there is an external supply (+24 V/0 V at terminals P24/M24).</li> </ul>						

- 1) I: Input; DO: Digital output, DI: Digital input, AO: Analog output; AI: Analog input; S: Supply
- 2) Can be freely parameterized. All of the digital inputs are de-bounced per software. When detecting the signal a delay time of between 1 and 2 interpolation clock cycles (P1010) is therefore incurred.
- 3) I0.x is internally hard-wired to the position sensing and acts there with almost no delay.
- 4) Can be freely parameterized. The digital outputs are updated in the interpolation clock cycle (P1010). A hardware-related delay time of approx. 200 μs must be added.
- 5) The permissible voltage range for the common mode component of the individual encoder signals (A+, A-, B+, B-, C+, C-, D+, D-, R+, R-) is 1.5...3.5 V.

## 4.2 "SIMODRIVE 611 universal HRS" control board

**Encoder  
connection  
X411/X412**

- Unconditioned signal

Table 4-12 Encoder signal input of motor encoder X411, X412 (unconditioned signal assignment)

Pin	X411 (axis 1) X412 (axis 2)	Function
1	PENC	Encoder power supply
2	MENC	Encoder power supply ground
3	AP	Incremental signal for track A
4	AN	Inverse incremental signal for track A
5	M	Inner shield ground
6	BP	Incremental signal for track B
7	BN	Inverse incremental signal for track B
8	M	Inner shield ground
9	–	Reserved, do not use
10	ENDATCLK	EnDat interface clock signal
11	–	Reserved, do not use
12	XENDATCLK	Inverse clock signal, EnDat interface
13	THMOTP	KTY 84 (+) temperature sensor
14	PSENSE	Remote sense encoder power supply (P)
15	ENDATDAT	Data signal EnDat interface
16	MSENSE	Remote sense encoder power supply (N)
17	RP	Reference mark signal/zero pulse
18	RN	Inverse reference mark signal/zero pulse
19	CP	Singleturn absolute track signal C
20	CN	Inverse singleturn absolute track signal C
21	DP	Singleturn absolute track signal D
22	DN	Inverse singleturn absolute track signal D
23	XENDATDAT	Inverse EnDat interface data signal
24	M	Inner shield ground
25	THMOTCOM	KTY 84 (–) temperature sensor

**Note:**

The inputs on the control must not be assigned any signals other than the intended signals. Otherwise, sporadic or permanent malfunction or damage can occur. In particular, any existing signals of additional temperature sensors (PTCs, NTCs, etc.) for spindle applications must **NOT** be applied to the unused CP, CN, DP, or DN inputs when using induction motors!

When "Parking axis" is selected, the encoder can be removed and inserted when power is present!

- Resolvers

Table 4-13 Encoder signal input of motor encoder X411, X412 (resolver)

Pin	X411 (axis 1) X412 (axis 2)	Function
1	–	Reserved, do not use
2	M	Ground
3	AP	Resolver, sinusoidal
4	AN	Resolver, sinusoidal, inverted
5	M	Inner shield ground
6	BP	Resolver, cosine
7	BN	Resolver, cosines, inverted
8	M	Inner shield ground
9	EXC_POS	Resolver excitation (pos.)
10	–	Reserved for test purposes, do not use
11	EXC_NEG	Resolver excitation (neg.)
12	–	Reserved for test purposes, do not use
13	THMOTP	KTY 84 (+) temperature sensor
14	–	Reserved, do not use
15	–	Reserved for test purposes, do not use
16	–	Reserved, do not use
17	–	Reserved, do not use
18	–	Reserved, do not use
19	–	Reserved, do not use
20	–	Reserved, do not use
21	–	Reserved, do not use
22	–	Reserved, do not use
23	–	Reserved, do not use
24	M	Inner shield ground
25	THMOTCOM	KTY 84 (–) temperature sensor
<b>Note:</b> The inputs on the control must not be assigned any signals other than the intended signals. Otherwise, sporadic or permanent malfunctions can occur.		



## 4.3 "HLA module" control board

### Description

The hydraulics (HLA) module provides a means of controlling hydraulic axes directly from the SINUMERIK 840D system via the digital drive bus.

The HLA module is a control unit belonging to the modular SIMODRIVE 611 converter system mounted in a 50 mm wide carrier module (universal empty housing). The gating and closed-loop control electronics for operating hydraulic drives are integrated in the HLA module.

The control unit can also be used as an ANA control unit for analog axes. This double-axis board can be used in mixed operation (HLA/ANA).

Hydraulic drives have the same significance as electric drives also when combined within an interpolating group.

---

### Note

The HLA module is described in detail in:

**References:** /FBHLA/, SINUMERIK 840D SIMODRIVE 611 digital HLA module, Description of Functions

---

### Features

The HLA module has the following features:

- Software and data
  - The communications interface is compatible with SIMODRIVE 611 SRM(FD)/ARM(MSD) for supported services. Code and data structure is analogous to SIMODRIVE 611 SRM(FD)/ARM(MSD). The hydraulics software is stored as a separate program code in the control system.
- Hardware
  - Integration into the SIMODRIVE 611 system is compatible with SIMODRIVE 611 digital SRM(FD)/ARM(MSD). Essentially, this involves the following interfaces:
    - Drive bus
    - Equipment bus
    - Power supply concept
- HLA control unit (2-axis)
  - Velocity pre-control, controller
  - Force control
  - Voltage output for actuators
  - Connection for two pressure sensors per axis
  - Control of hydraulic control valves
- Terminals and diagnostics
  - Control of a hydraulic shut-off valve
  - BERO input per axis
  - Module-specific enable signal
  - Test sockets (diagnostics)

### 4.3.1 System overview

A complete SINUMERIK 840D with HLA module comprises of various individual components. These are listed below.

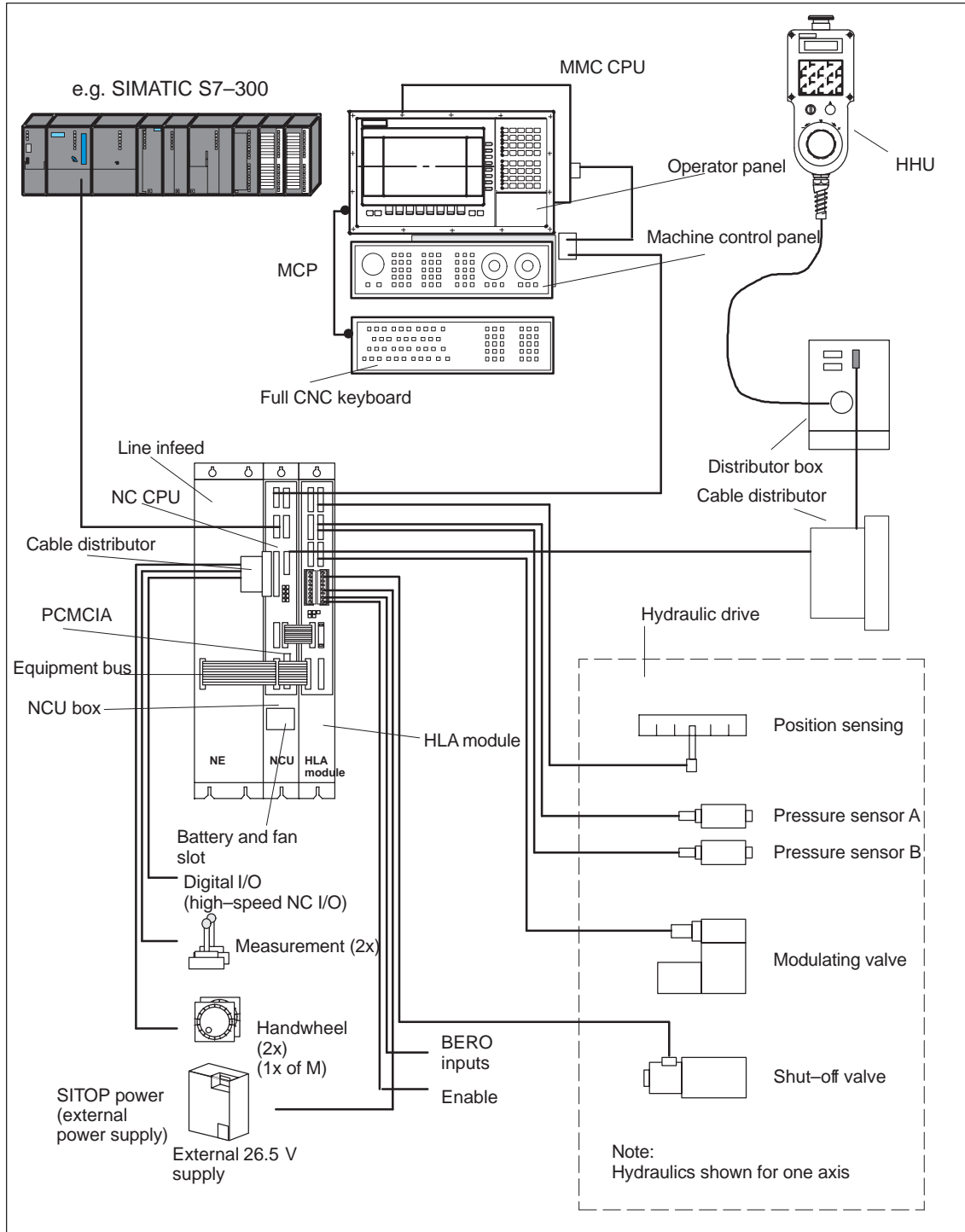

Fig. 4-8 System components

4.3 "HLA module" control board

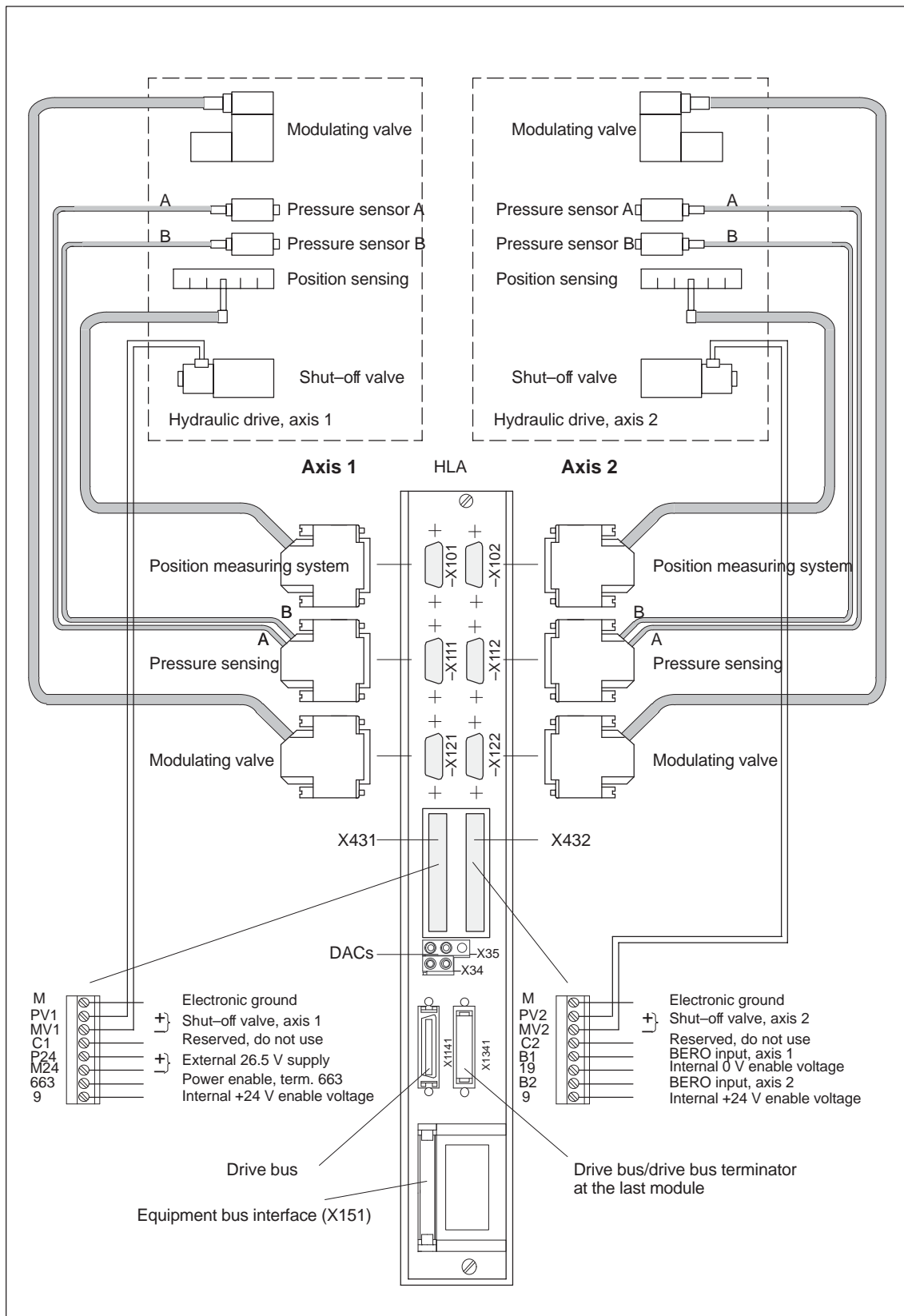

Fig. 4-9 Connection configuration for HLA module

### 4.3.2 Wiring

#### Line supply connection

The SINUMERIK 840D and the HLA module are supplied from the SIMODRIVE line supply infeed or from the SIMODRIVE monitoring module via the equipment bus. There must be at least one NE module in the equipment group when an HLA module is used. No provision has been made for any other type of voltage supply and failure to use the supply provided could damage the unit.

#### Note

It is not permissible to operate an HLA module on its own with a SIMODRIVE monitoring module!

Power is supplied to downstream electrical axes via the DC link busbars (40 mm<sup>2</sup>) of the carrier module.

#### Measuring systems

One position encoder for each axis can be evaluated on the HLA module.

- X101: Axis 1
- X102: Axis 2

The measuring system must always be plugged into the connector of the associated axis.

Table 4-14 Connectors X101, X102; 15-pin sub-D plug connector (two-tier)

Pin	X101 <sup>1)</sup>	X102 <sup>1)</sup>	Function
1	PENC0	PENC2	Encoder power supply 5 V ± 5%, 300 mA
2	M	M	Encoder power supply ground
3	AP0	AP2	Incremental signal for track A
4	AN0	AN2	Inverse incremental signal for track A
5	ENDATDAT0	ENDATDAT2	EnDat or SSI interface data signal
6	BP0	BP2	Incremental signal for track B
7	BN0	BN2	Inverse incremental signal for track B
8	XENDATDAT0	XENDATDAT2	Inverse EnDat or SSI interface data signal
9	PSENSE0	PSENSE2	Remote sense encoder power supply (P)
10	RP0	RP2	Zero pulse/reference mark signal A
11	MSENSE0	MSENSE2	Remote sense encoder power supply (M)
12	RN0	RN2	Inverse zero pulse/reference mark signal A
13	M	M	Ground (for internal shields)
14	ENDATCLK0	ENDATCLK2	EnDat or SSI interface clock signal
15	XBMICLK0	XBMICLK2	Inverse EnDat interface clock signal

**Note:** The SSI encoder requires an external 24 V power supply

1) The permissible voltage range for the common mode component of the individual encoder signals (AP, AN, BP, BP, RP, RP) is 1.5...3.5 V.

## 4.3 "HLA module" control board

**Pressure sensor system**

Connection for two pressure sensors per axis

- X111: Axis 1 (sensors 1A, 1B)
- X112: Axis 2 (sensors 2A, 2B)

Table 4-15 Connectors X111, X112; each 15-pin sub-D socket connector

Pin	X111	X112	Type <sup>1)</sup>	Function
1	P24DS	P24DS	O	External +24 V supply for the pressure sensor
2	P24DS	P24DS	O	External +24 V supply for the pressure sensor
3	–	–	–	Not assigned
4	–	–	–	Not assigned
5	M24EXT	M24EXT	O	External 0 V supply for the pressure sensor
6	–	–	–	Not assigned
7	–	–	–	Not assigned
8	–	–	–	Not assigned
9	M24EXT	M24EXT	O	External 0 V supply for the pressure sensor
10	M24EXT	M24EXT	O	Extra pin for jumper between pins 10–11 with 3-wire connection
11	PIST1BN	PIST2BN	I	Analog actual value signal, reference ground
12	PIST1BP	PIST2BP	I	Analog actual value signal, max. range 0...+10 V
13	M24EXT	M24EXT	O	Extra pin for jumper between pins 13–14 with 3-wire connection
14	PIST1AN	PIST2AN	I	Analog actual value signal, reference ground
15	PIST1AP	PIST2AP	I	Analog actual value signal, max. range 0...+10 V
1) I = Input, O = Output				

The inputs are differential with 40 kΩ input resistance.

The input voltage range is 0...+10 V.

The supply output has an electronic short-circuit protection function.

The supply output is dimensioned for a total current (4 sensors) of 200 mA.

Supply for pressure sensors with 26.5 V ± 2% according to the external infeed at X431.

**Notice**

The external 26.5 V supply voltage cannot be replaced by a 24 V supply voltage.

**Modulating valve**

- X121: Axis 1
- X122: Axis 2

Table 4-16 Connectors X121, X122; both are 15pin sub-D socket connectors

Pin	X121	X122	Type <sup>1)</sup>	Function
1	P24RV1	P24RV2	O	+24 V switched
2	P24RV1	P24RV2	O	+24 V switched
3	P24RV1	P24RV2	O	+24 V switched
4	P24RV1	P24RV2	O	+24 V switched
5	M	M		Electronic ground
6	USOLL1N	USOLL2N	O	Analog setpoint output, reference ground
7	USOLL1P	USOLL2P	O	Analog setpoint output +/-10 V
8	M	M		Electronic ground
9	M24EXT	M24EXT	O	24 V external ground
10	M24EXT	M24EXT	O	24 V external ground
11	M24EXT	M24EXT	O	24 V external ground
12	–	–		Not assigned
13	M	M		Electronic ground
14	UIST1N	UIST2N	I	Analog valve actual-value input, reference ground
15	UIST1P	UIST2P	I	Analog valve actual-value input, +/-10 V
1) I = Input, O = Output				

The analog valve actual value inputs are differential with 100 kΩ input resistance.

The current ratings of the 24 V outputs of the control valves are

- for an ambient temperature of 40 °C 2.0 A
- for an ambient temperature of 55 °C 1.5 A

for the mean current value with a load cycle of 10 s duration.

The temperature corner points may be interpolated linearly.

The short-term current rating of the control valve outputs is 3.0 A (200 ms).

In the event of an overload, the F1900 or F1901 fuse on the HLA control unit blow.

**Fuse**

The switched 24 V outputs for axes 1 and 2 are protected by F1900 (axis 1) or F1901 (axis 2) miniature fuses.

Value: 2.5 AF/250 V; 5x20 mm UL

From: Wickmann-Werke GmbH  
Annenstrasse 113  
58453 Witten, Germany  
or  
Postfach 2520  
58415 Witten

Order No.: 194

## 4.3 "HLA module" control board

## Terminals

Shut-off valves (axis-specific), external 26.5 V supply, enable contact, BERO inputs

- X431: Axis 1
- X432: Axis 2

Table 4-17 Connector X431; 8-pin Phoenix Combicon connector

Pin	X431	Type <sup>1)</sup>	Function	Typ. voltage/ limit values
1	M	I	Electronic ground	
2	PV1	O	+24 V shut-off valve axis 1	Max. 2.0 A
3	MV1	O	Ground for shut-off valve for axis 1	
4	C1	–	Reserved, do not use	
5	P24	I	Input for external +26.5 V	26.5 V ± 2%
6	M24	I	Input for external 0 V	
7	663	I	Module-specific enable signal	21 V ... 30 V
8	9	O	Internal +24 V enable voltage, term. 9	
1) I = Input, O = Output				

Table 4-18 Connector X432; 8-pin Phoenix Combicon connector

Pin	X432	Type <sup>1)</sup>	Function	Typ. voltage/ limit values
1	M	I	Electronic ground	
2	PV2	O	+24 V shut-off valve axis 2	Max. 2.0 A
3	MV2	O	Ground for shut-off valve for axis 2	
4	C2	–	Reserved, do not use	
5	B1	I	BERO input, axis 1	15 V ... 30 V
6	19	O	Internal enable voltage, ground, term. 19	
7	B2	I	BERO input, axis 2	15 V ... 30 V
8	9	O	Internal +24 V enable voltage, term. 9	
1) I = Input, O = Output				

Max. terminal cross-section 2.5 mm<sup>2</sup>.

**Caution**

The +24 V outputs for shut-off valves for axes 1 and 2 are short-circuit proof. The energy absorbed when inductive loads are disconnected must be limited to 1.7 J by the user. When the supply polarity is reversed, the outputs are not protected against overload.

**Warning**

If the polarity of the 26.5 V supply is reversed, then the shut-off valves will open immediately, even if the NC or closed-loop control is not in operation!

**Notice**

Each of the shut-off valves must be connected directly using two conductors connected to pins 2/3 of X431 or X432!

A current-compensated interference suppression coil is inserted at the input for the external incoming supply terminal P24, terminal M24 (pins 5 and 6 of X431).

Terminal M24 and terminal MV1/MV2 may therefore not be reversed or short-circuited.

The internal enable voltage (FRP/9) is provided in order to supply the BEROs, and terminals 663 may **not** be used to supply the hydraulics components. The hydraulic components must be supplied via incoming supply P24. The voltages may not be connected in parallel.

**Input enable**

Module-specific enabling commands are issued by terminal 663. As no power section is installed, no relay is available. The input is therefore evaluated via optocouplers in the HLA module and also acts on the shut-off valves. The enable voltage can be taken from terminal 9.

Terminal 663 is referenced to the internal enable voltage (ground, terminal 19).

**4.3.3 Test sockets (diagnostics)****Measuring sockets**

The start-up tool or an MMC102/103 can be used to assign internal signals to the test sockets on the 611D drive (in conjunction with SINUMERIK 840D), where the signals are then available as analog values.

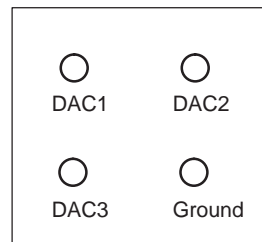
**Functionality**

Three 8-bit digital/analog converter (DAC) channels are available on the 611D hydraulics module. An analog image of various drive signals can be connected through to a test socket via these converters.

Only a window of the 24-bit wide drive signals can be displayed with the 8 bits (=1 byte) of the DAC. For this reason, the shift factor must be set to determine how fine the quantization of the selected signal must be. The normalization factor is determined when parameterizing and displayed to the user.



## 4.4 "ANA module" control board

### Description

Up to two analog axes can be controlled by using the ANA control unit. The ANA module results when the ANA control unit is inserted in the 50 mm wide universal empty housing.

The control unit can also be used as an HLA control unit for hydraulic axes. This double-axis board can be used in mixed operation (HLA/ANA).

An analog axis can be used very much like a digital axis. It can be programmed like a digital interpolating path axis or spindle. Pure functions of the SIMODRIVE 611 drive control system are, of course, not possible for external drive units linked via an analog speed setpoint interface. (These are functions which are dependent on feedback within the axis and communication by means of the drive bus, e.g. SINUMERIK Safety Integrated.) If necessary, separate EMC measures must be taken for external drive units.

---

### Note

The ANA module is described in detail in:

**References:** /FBANA/, SINUMERIK 840D SIMODRIVE 611 digital ANA module, Description of Functions

---

### Features

The ANA module has the following features:

- Software and data
  - The communications interface is compatible with SIMODRIVE 611 SRM(FD)/ARM(MSD) for supported services. Code and data structure is analogous to SIMODRIVE 611 SRM(FD)/ARM(MSD).
- Hardware
  - Integration into the SIMODRIVE 611 system is compatible with SIMODRIVE 611 digital SRM(FD)/ARM(MSD). Essentially, this involves the following interfaces:
    - Drive bus
    - Equipment bus
    - Power supply concept
- ANA control unit (2-axis)
  - $n_{\text{set}}$  output  $\pm 10$  V
  - Connection for 2 sensors per axis
  - Control of an analog drive amplifier
- Terminals and diagnostics
  - BERO input per axis
  - Module-specific enable signal
  - Test sockets (diagnostics)

### 4.4.1 System overview

A complete 840D control with ANA module comprises various individual components. These are listed below.

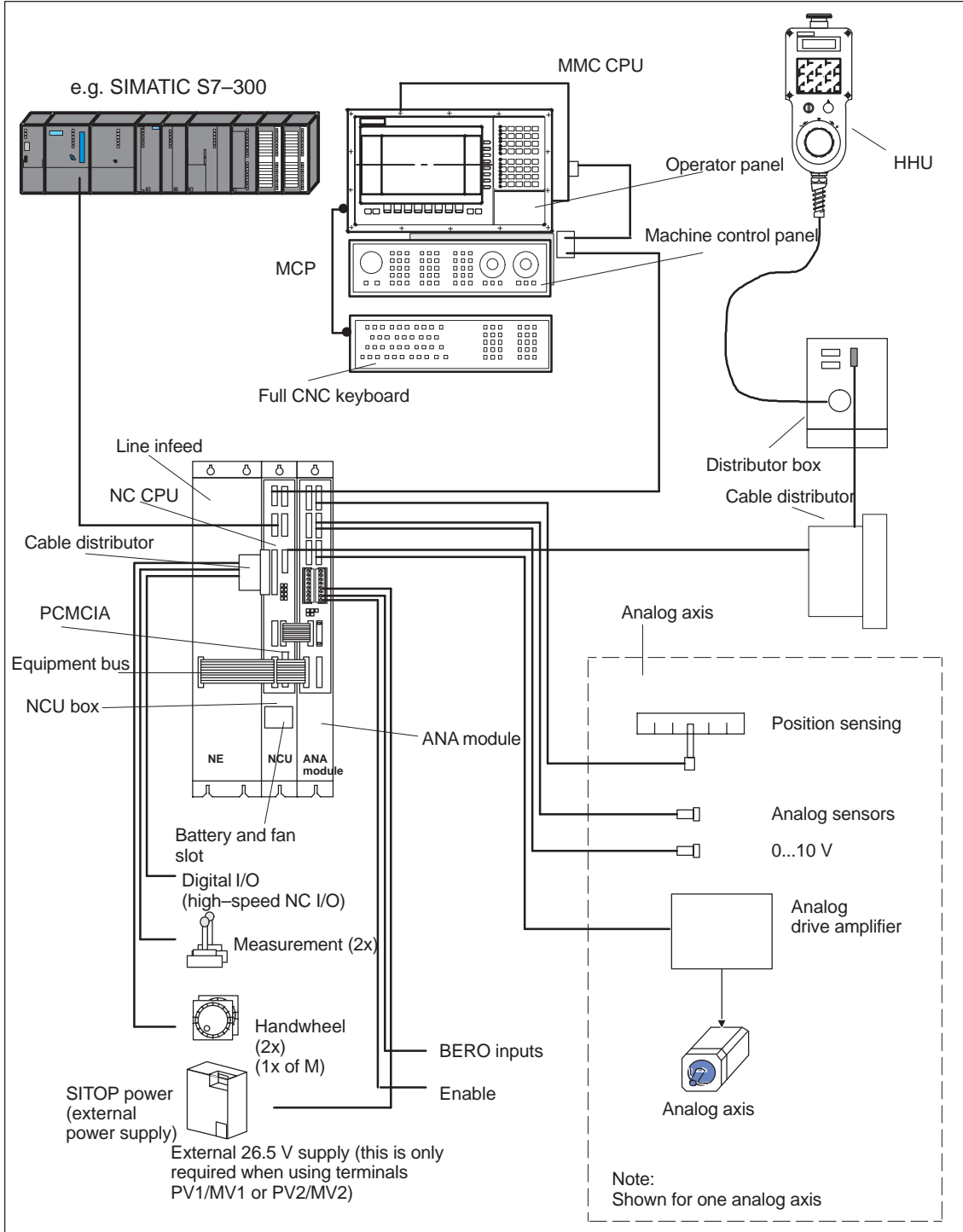

Fig. 4-10 System components

4.4 "ANA module" control board

ANA control unit

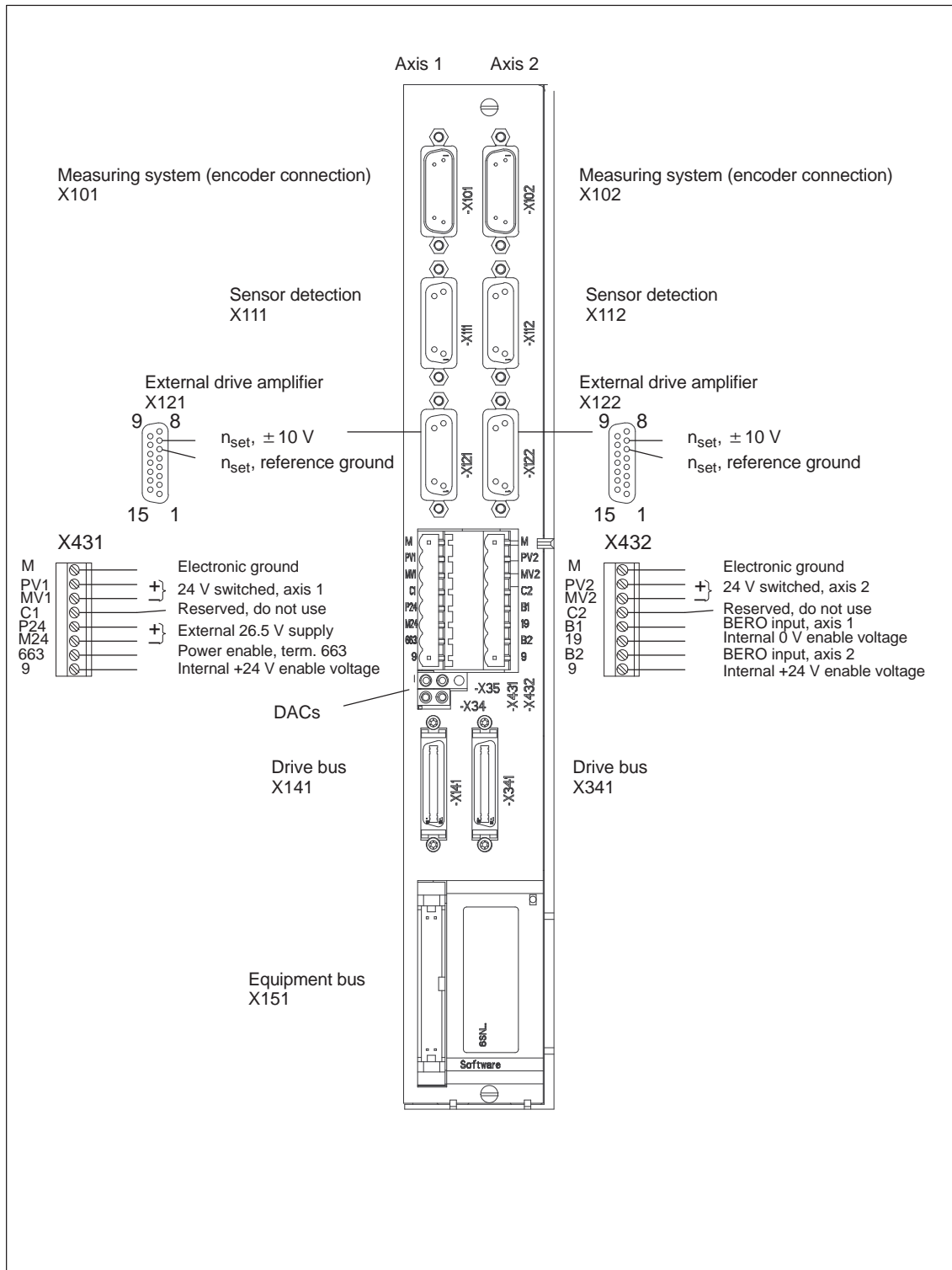

Fig. 4-11 ANA control unit (2-axis)

## 4.4.2 Wiring

### Line supply connection

SINUMERIK 840D and the ANA module are supplied from the SIMODRIVE line supply voltage or from the SIMODRIVE monitoring module via the equipment bus. There must be at least one NE module in the equipment group when an ANA module is used. No provision has been made for any other type of voltage supply and failure to use the supply provided could damage the unit.

#### Notice

It is not permissible to operate an ANA module on its own with a SIMODRIVE monitoring module!

Power is supplied to downstream electrical axes via the DC link busbars (40 mm<sup>2</sup>) of the carrier module.

### Measuring systems

One position encoder for each axis can be evaluated on the ANA module.

- X101: Axis 1
- X102: Axis 2

The measuring system must always be plugged into the connector of the associated axis.

Table 4-19 Connectors X101, X102; 15-pin sub-D plug connector (two-tier)

Pin	X101 <sup>1)</sup>	X102 <sup>1)</sup>	Function
1	PENC0	PENC2	Encoder power supply
2	M	M	Encoder power supply ground
3	AP0	AP2	Incremental signal A
4	AN0	AN2	Inverse incremental signal A
5	BMIDAT0	BMIDAT2	Data signal EnDat interface
6	BP0	BP2	Incremental signal B
7	BN0	BN2	Inverse incremental signal B
8	XBMIDAT0	XBMIDAT2	Inverse EnDat interface data signal
9	PSENSE0	PSENSE2	Remote sense encoder power supply (P)
10	RP0	RP2	Incremental signal R
11	MSENSE0	MSENSE2	Remote sense encoder power supply (M)
12	RN0	RN2	Inverse incremental signal R
13	M	M	Ground (for internal shields)
14	BMICLK0	BMICLK2	EnDat interface clock signal
15	XBMICLK0	XBMICLK2	Inverse EnDat interface clock signal
1) The permissible voltage range for the common mode component of the individual encoder signals (AP, AN, BP, BN, RP, RN) is 1.5...3.5 V.			

## 4.4 "ANA module" control board

## Analog sensors

Connection for two sensors per axis

- X111: Axis 1 (sensors 1A, 1B)
- X112: Axis 2 (sensors 2A, 2B)

Table 4-20 Connectors X111, X112; each 15-pin sub-D socket connector

Pin	X111	X112	Type 1)	Function
1	P24DS	P24DS	O	External +24 V supply for the sensor
2	P24DS	P24DS	O	External +24 V supply for the sensor
3	–	–		Not assigned
4	–	–		Not assigned
5	M24EXT	M24EXT	O	External 0 V supply for the sensor
6	–	–		Not assigned
7	–	–		Not assigned
8	–	–		Not assigned
9	M24EXT	M24EXT	O	External 0 V supply for the sensor
10	M24EXT	M24EXT	O	Extra pin for jumper between pins 10–11 with 3-wire connection
11	<b>PIST1BN</b>	<b>PIST2BN</b>	I	<b>Analog actual value signal, reference ground</b>
12	<b>PIST1BP</b>	<b>PIST2BP</b>	I	<b>Analog actual value signal, max. range 0...10 V</b>
13	M24EXT	M24EXT	O	Extra pin for jumper between pins 13–14 with 3-wire connection
14	<b>PIST1AN</b>	<b>PIST2AN</b>	I	<b>Analog actual value signal, reference ground</b>
15	<b>PIST1AP</b>	<b>PIST2AP</b>	I	<b>Analog actual value signal, max. range 0...10 V</b>
1) I = Input, O = Output				

The inputs are differential inputs with an input resistance of 40 kΩ each.  
The input voltage range of the actual value inputs is 0...+10 V.

The supply output has an electronic short-circuit protection function.  
The supply output is dimensioned for a total current (4 sensors) of 200 mA.

### Analog setpoints and actual values

- X121: Axis 1
- X122: Axis 2

Table 4-21 Connectors X121, X122; both are 15pin sub-D socket connectors

Pin	X121	X122	Type <sup>1)</sup>	Function
1	P24RV1	P24RV2	O	P24EXT switched, from X431.5
2	P24RV1	P24RV2	O	P24EXT switched, from X431.5
3	P24RV1	P24RV2	O	P24EXT switched, from X431.5
4	P24RV1	P24RV2	O	P24EXT switched, from X431.5
5	M	M		Electronic ground
6	<b>USOLL1N</b>	<b>USOLL2N</b>	O	<b>Analog setpoint output, reference ground</b>
7	<b>USOLL1P</b>	<b>USOLL2P</b>	O	<b>Analog setpoint output +/-10 V</b>
8	M	M		Electronic ground
9	M24EXT	M24EXT	O	M24EXT, from X431.6
10	M24EXT	M24EXT	O	M24EXT, from X431.6
11	M24EXT	M24EXT	O	M24EXT, from X431.6
12	–	–		Not assigned
13	M	M		Electronic ground
14	<b>UIST1N</b>	<b>UIST2N</b>	I	<b>Analog actual value input, reference ground</b>
15	<b>UIST1P</b>	<b>UIST2P</b>	I	<b>Analog valve actual-value input, +/-10 V</b>
1) I = Input, O = Output				

The analog actual value inputs are differential inputs with an input resistance of 100 k $\Omega$  each.

The load capability of the 24 V outputs (P24RV1/2) is

- for an ambient temperature of 40 °C      2.0 A
- for an ambient temperature of 55 °C      1.5 A

for the mean current value with a load cycle of 10 s duration.

The temperature corner points may be interpolated linearly.

The short-term current rating of the 24 V outputs is 3.0 A (200 ms).

In the event of an overload, the F1900 or F1901 fuse on the ANA control unit will blow.

### Fuse

The switched 24 V outputs for axes 1 and 2 are protected by F1900 (axis 1) or F1901 (axis 2) miniature fuses.

Value: 2.5 AF/250 V; 5x20 mm UL

From: Wickmann-Werke GmbH  
Annenstrasse 113  
58453 Witten, Germany  
or  
Postfach 2520  
58415 Witten

Order No.: 19194

## 4.4 "ANA module" control board

**Terminals**

External 26.5 V infeed, enable, BERO inputs

- X431: Axis 1
- X432: Axis 2

Table 4-22 Connector X431; 8-pin Phoenix Combicon connector

Pin	X431	Type <sup>1)</sup>	Function	Typ. voltage/limit values
1	M	I	Electronic ground	
2	PV1	O	P24EXT switched, axis 1	Max. 2.0 A
3	MV1	O	M24EXT switched, axis 1	
4	C1	–	Reserved, do not use	
5	P24	I	Input for external +24 V	26.5 V ±2%
6	M24	I	Input for external 0 V	
7	663	I	Module-specific enable signal	21 V...30 V
8	9	O	Enable voltage, internal, +24 V	
1) I = Input, O = Output				

Table 4-23 Connector X432; 8-pin Phoenix Combicon connector

Pin	X432	Type <sup>1)</sup>	Function	Typ. voltage/limit values
1	M	I	Electronic ground	
2	PV2	O	P24EXT switched, axis 2	Max. 2.0 A
3	MV2	O	M24EXT switched, axis 2	
4	C2	–	Reserved, do not use	
5	B1	I	BERO input, axis 1	15 V...30 V
6	19	O	Internal enable voltage, ground, term.19	
7	B2	I	BERO input, axis 2	15 V...30 V
8	9	O	Enable voltage, internal, +24 V	
1) I = Input, O = Output				

**Notice**

A connection (jumper) between X431.6 and X432.3 is **not permissible!**

Max. terminal cross-section 2.5 mm<sup>2</sup>.

It is only necessary to supply terminals X431 pins 5 and 6 with 24 V if the 24 V outputs of connectors X111/112, X121/122 or X431/432 are to be used.

**Caution**

The +24 V outputs for shut-off valves for axes 1 and 2 are short-circuit proof. The energy absorbed when inductive loads are disconnected must be limited to 1.7 J by the user. When the supply polarity is reversed, the outputs are not protected against overload.

**Input enable**

The module-specific enable is realized using terminal 663. The input is evaluated via the optocoupler in the ANA module. The enable voltage can be taken from terminal 9.

Terminal 663 is referenced to the internal enable voltage (ground, terminal 19).

**4.4.3 Bus interfaces****Drive bus**

(refer to SIMODRIVE 611 digital)

- X141: Input
- X341: Output

A bus terminator must be plugged into the last module.

**Equipment bus**

(refer to SIMODRIVE 611 digital)

- X151: Equipment bus



---

4.4 "ANA module" control board

## Power Modules

### 5.1 Description

<b>General</b>	Together with the control module, the power module forms the drive module, for feed or main spindle applications.
<b>Motors that can be connected</b>	<p>The power modules can be used to operate the following motors:</p> <ul style="list-style-type: none"> <li>• 1FT6, 1FK6 and 1FK7 servo motors</li> <li>• 1FW6 built-in torque motors (direct drives)</li> <li>• 1FN linear motors</li> <li>• 1PH main spindle motors</li> <li>• Standard induction motors; if IM operation is selected, only inverter pulse frequencies of 4 kHz and 8 kHz are permissible.</li> <li>• 1PM hollowshaft motors for main spindle drives (direct drives)</li> <li>• 1FE1 main spindle motors</li> <li>• 2SP1 motor spindle</li> <li>• Third-party motors, if according to the motor manufacturer the motor meets the requirements for sine modulation, insulation, and dV/dt resistance (see Chapter 8.1).</li> </ul> <p>For special motors with a low leakage inductance (where the controller settings are not adequate), it may be necessary to provide a series reactor in the form of a 3-arm iron core reactor (not a Corovac reactor) and/or increase the inverter pulse frequencies of the converter. Motors with a low leakage inductance are, from experience, motors that can achieve high stator frequencies (maximum motor stator frequency &gt; 300 Hz) or motors with a high rated current (rated current &gt; 85 A).</p>
<b>Available power modules</b>	<p>A wide range of 1-axis or 2-axis power modules is available. These modules are graded according to the current ratings and can be supplied with three different cooling techniques.</p> <p>The current-related data refers to the series-preset values. At higher frequencies of the fundamental waves or for higher clock cycle frequencies, ambient temperatures and installation altitudes above 1000 m above sea level, power deratings apply as subsequently listed.</p>
<b>Wiring</b>	<p>Matched, pre-assembled cables are available to connect the motors. Ordering information is provided in the "Motors" section of the NC 60 catalog.</p> <p>Shield terminal plates are available to meet EMC requirements when using shielded power cables.</p>

## 5.1 Description

The equipment bus cable is included in the scope of supply of the power module. The drive bus cables must be ordered separately for the digital system.

The current data of the power modules (PM modules) are normalized values to which all of the control units refer. The output currents can be limited by the control unit being used.

**Caution**

After the control unit has been inserted, the retaining screws of the control unit front panel must be tightened in order to establish a good electrical connection to the module housing.

The power module is equipped with overload protection, which when correspondingly dimensioned, prevents the motors and cables from being overloaded. The overload protection functions as described in the documentation SINUMERIK 840D/810D drive functions, Chapter 2.4.1. It does not fully comply with the requirements as specified in UL508C Version 2010, regarding cable protection

**Power module,  
internal cooling**

Fig. 5-1 Power module with control unit

## 5.2 Operating modes

### Feed drives

- with synchronous motors (FD)
  - 1FT6, 1FK6 and 1FK7 servo motors
  - 1FW6 built-in torque motors (direct drives)
  - 1FN linear motors

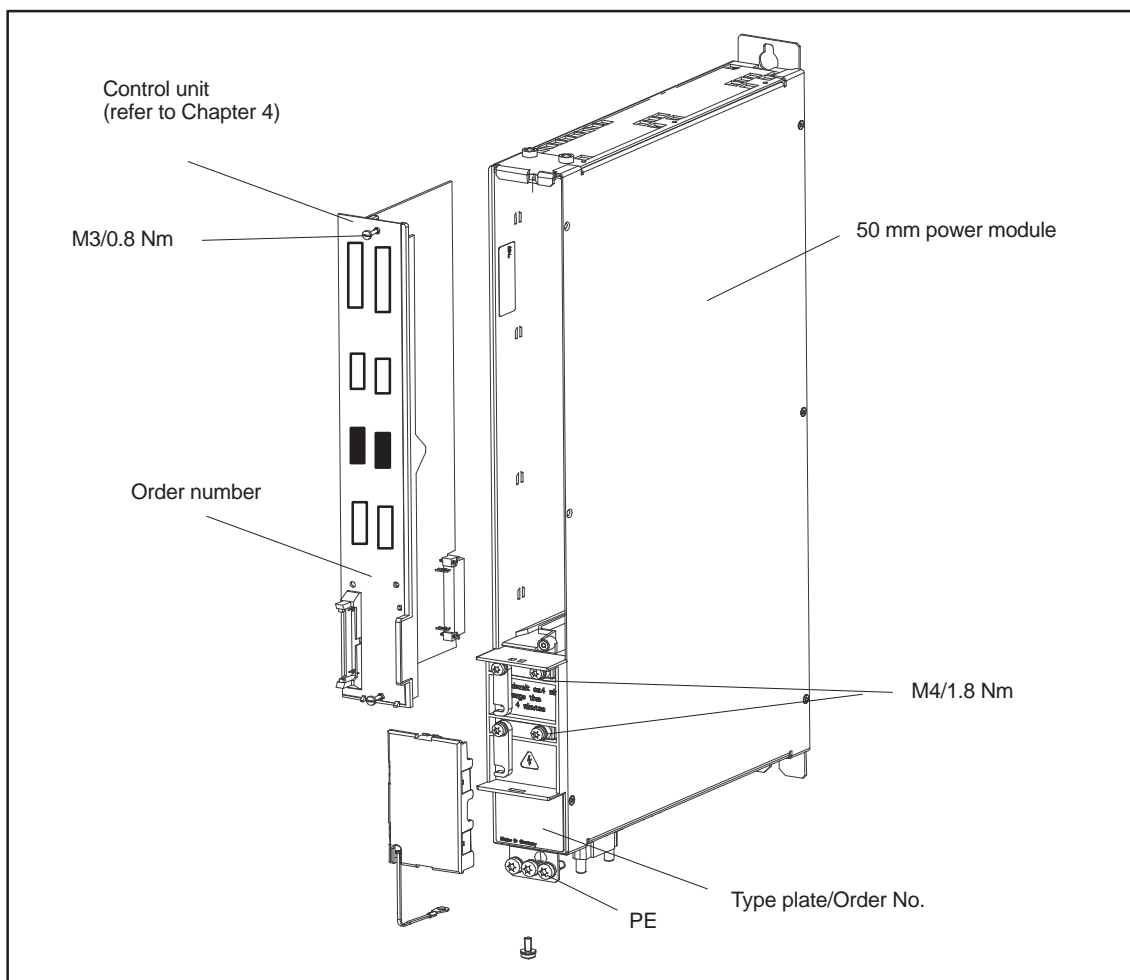
### Main spindle drives

- with induction motors (MSD-IM)
  - 1PH main spindle motors
  - 1PM hollowshaft motors for main spindle drives (direct drives)
  - standard induction motors (sensorless)

If IM operation is selected, only inverter pulse frequencies of 4 kHz and 8 kHz are permissible.
- with synchronous motors (MSD-SRM)
  - 1FE1 main spindle motors
  - 2SP1 motor spindle

---

#### Note

For the MSD-SRM operating mode (high-speed MSD synchronous applications), inverter pulse frequencies are set that differ from the rated frequencies. This consequently ensures an optimum ratio between the inverter pulse frequency and the output frequency.

The derating resulting from this should be taken into account when selecting the power module.

The frequencies relevant when engineering the system should be appropriately taken from the following documentation.

---



#### Reader's note

Technical data and ordering data, refer to

**Reference:** /PJFE/ Configuration Manual, 1FE1 Synchronous Built-in Motors  
 /BU/ Catalog NC 60 2004  
 /PMS/ Configuration Manual ECO Motor Spindles for 2SP1 Main Spindle Drives  
 WEISS GmbH/Operating Instructions ECO Spindle Units Type 2SP1...

---

## 5.3 Technical data

### General

The technical data of the power modules is specified in Table 5-1 for the 1-axis version and in Table 5-2 for the 2-axis version.

The specified values are valid for:

- The specified rated frequency (inverter pulse frequency)
- Maximum ambient temperature of 40 °C
- Installation altitude < 1000 m above sea level

Derating must be applied for conditions that deviate from those specified above. The power modules do not have any overload protection, but only a current acquisition without its own processing. The overload protection is realized in the SIMODRIVE 611 control unit.

### Definition of the currents

Also refer to the definition of the load duty cycles (Fig. 5-2 to 5-5)

- FD mode
  - $I_n$  Continuous nominal current, rated current
  - $I_{max}$  Peak current
- Operating modes, MSD-IM and MSD-SRM
  - $I_n$  Continuous nominal current, rated current
  - IS6-40% Current for maximum of 4 min. for the S6 load duty cycle
  - $I_{max}$  Peak current
  - $I_{min}$  Minimum motor current
  - $n_{FS}$  Speed at the start of field weakening
  - $I_{0Mot}$  Motor no-load current in  $A_{rms}$

The following restrictive conditions must be met:

#### for induction motors:

- The no-load current of the motor ( $I_{0Mot}$ ) must be less than the rated current of the power module (according to Table 5-1).
- On the basis of the actual current value resolution, the lowest occurring no-load current of the motor must satisfy the following condition:

$$\frac{n_{FS}}{n_{max}} \cdot I_{0Mot} \geq I_{min} \quad (I_{min} \text{ according to Table 5-1})$$

#### for synchronous motors:

A ratio of  $I_{max\_powersection}/I_{0\_100K}(\text{motor}) \sim 5$  should not be exceeded for synchronous motors.

### Definition of the power ratings

Appropriate values are specified in Table 5-1 and 5-2 to dimension the cabinet cooling. These are defined as follows:

- $P_{Vtot}$  Total power loss dissipated by the module
- $P_{Vext}$  Power loss that can be dissipated externally or using hose cooling
- $P_{Vint}$  Power loss that cannot be dissipated using hose cooling or external cooling (this power loss remains in the control cabinet)

For components with internal cooling, the complete dissipated power loss remains in the control cabinet.

Table 5-1 Power modules in the 1-axis version

6SN112□-1AA0□-		0HA□	0AA□	0BA□	0CA□	0DA□	0LA□	0EA□	0FA□	0JA□	0KA□
↑ 3 internal cooling 4 external cooling <sup>1)</sup>											
Mounting frame external cooling 6SN1162-0BA04-		0AA□			0FA□	0BA□	0CA□		0EA□		
Type of cooling		Non-ventilated			Fan						
For operation of induction motors											
Nominal current I <sub>n</sub>	A <sub>eff</sub>	3	5	8	24	30	45	60	85	120	200
Current for S <sub>6</sub> -40% I <sub>S6-40%</sub>	A <sub>eff</sub>	3	5	10	32	40	60	80	110	150	250
Peak current I <sub>max</sub>	A <sub>eff</sub>	3	8	16	32	51	76	102	127	193	257
Inverter pulse frequency f <sub>0</sub>	kHz	3.2									
Derating factor X <sub>L</sub>	%	50			55		50		55		
Power loss, total P <sub>Vtot</sub>	W	30	40	74	260	320	460	685	850	1290	2170
Power loss, internal P <sub>Vint</sub>	W	12	16	29	89	32	19	30	100	190	325
Power loss, external P <sub>Vext</sub>	W	18	24	45	171	288	441	655	750	1100	1845
For operation of synchronous motors											
Nominal current I <sub>n</sub>	A <sub>eff</sub>	3	5	9	18	28	42	56	70	100	140
Peak current I <sub>max</sub>	A <sub>eff</sub>	6	10	18	36	56	64	112	140	100	210
Inverter pulse frequency f <sub>0</sub>	kHz	4									
Derating factor X <sub>L</sub>	%	55			50		55				
Power loss, total P <sub>Vtot</sub>	W	35	50	90	190	300	460	645	730	1300	1910
Power loss, internal P <sub>Vint</sub>	W	14	19	35	65	30	25	25	90	170	250
Power loss, external P <sub>Vext</sub>	W	21	31	55	125	270	435	620	640	1130	1660
General technical data for the regulated infeed											
Input voltage	V DC	Regulated: 600 V or 625 V DC, unregulated: U <sub>DC link</sub> =U <sub>Supply</sub> • 1.35									
Maximum output voltage	V <sub>eff</sub>	U <sub>a,max</sub> = U <sub>DC link</sub> /1.4									
Minimum motor current I <sub>min</sub> <sup>5)</sup>	A	0.6	1.1	1.8	3.6	5.7	8.5	11	14	21	28
Transistor limit current	A	8	15	25	50	80	108	160	200	300	400
Efficiency		0.98									
Module width	mm	50			100		150		300 <sup>2)</sup>		
Weight, approx.	kg	6.5			9.5		13		26		28
Maximum air flow of fan (volumetric flow, unobstructed flow per fan)	m <sup>3</sup> /hr	-	-	19	22	56	2x56	2x56 <sup>3)</sup>	2x51 <sup>2)</sup>	-	-
Motor connection		Connectors					Terminals				

- 1) For a module width of 300 mm with external cooling, mounting frames are required that must be separately ordered. The fan assembly required to mount the built-on fan is included in the scope of supply of the mounting frame. The built-on fan must be separately ordered! Mounting frames are also available for smaller module widths. However, these are not required if openings are cut out in the rear cabinet panel for the module heatsinks as shown in this Configuration Manual.
- 2) For 6SN1123-1AA0□-0JA□/0KA□ and 6SN1124-1AA0□-0FA□/-0JA□/-0KA□, the built-on fan 6SN1162-0BA02-0AA2 is required.
- 3) Is applicable for internal cooling. For external cooling with mounted fan 2) 400 m<sup>3</sup>/h
- 4) True for induction motors and applies to the no-load current.

## 5.3 Technical data

Table 5-2 Power modules in the 2-axis version

6SN112□-1AB00- ↑ 3 internal cooling 4 external cooling		0HA□	0AA□	0BA□	0CA□
Mounting frame external cooling 6SN1162-0BA04-			0AA□		0GA□
Type of cooling		Fan			
For operation of induction motors <sup>1)</sup>					
Nominal current $I_n$	$A_{eff}$	3	5	8	24
Current for S6-40% $I_{S6-40\%}$	$A_{eff}$	3	5	10	32
Peak current $I_{max}$	$A_{eff}$	3	8	16	32
Inverter pulse frequency $f_0$	kHz	3.2			
Derating factor $X_L$	%	55			
For operation of synchronous motors					
Nominal current $I_n$	$A_{eff}$	3	5	9	18
Peak current $I_{max}$	$A_{eff}$	6	10	18	36
Inverter pulse frequency $f_0$	kHz	4			
Derating factor $X_L$	%	55			
Power loss, total $P_{Vtot}$	W	76	118	226	538
Power loss, internal $P_{Vint}$	W	28	42	74	184
Power loss, external $P_{Vext}$	W	48	76	152	354
General technical data for the regulated infeed					
Input voltage	V DC	regulated: 600 V or 625 V DC, unregulated: $U_{DC\ link} = U_{Supply} \cdot 1.35$			
Maximum output voltage	$V_{eff}$	$U_{a\_max} = U_{DC\ link} / 1.4$			
Minimum motor current $I_{min}^{2)}$	A	0.6	1.1	1.8	3.6
Transistor limit current	A	8	15	25	50
Efficiency		0.98			
Module width	mm	50			100
Weight, approx.	kg	7			13.5
Maximum air flow of fan (volumetric flow)	$m^3/hr$	-	-	19	56
Motor connection		Connectors			

1) For IM operation, corresponding to the selected 4/8 kHz inverter pulse frequency, an appropriate derating must be observed.

2) True for induction motors and applies to the no-load current.

## Load duty cycles

- Rated load duty cycles for FD operation

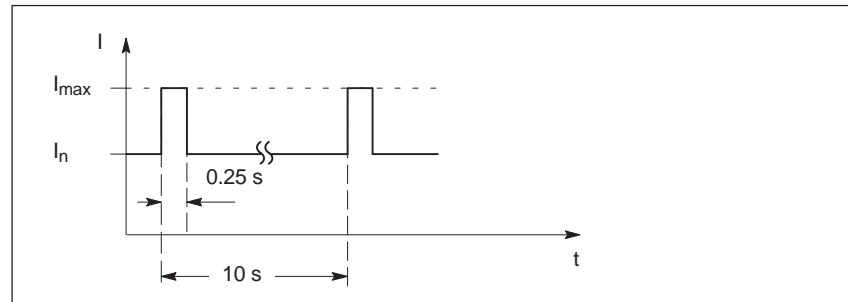

Fig. 5-2 Peak current load duty cycle with preload condition

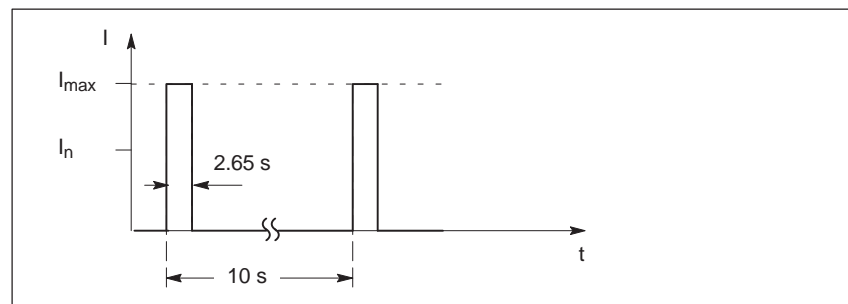

Fig. 5-3 Peak current duty cycle without preloading condition

- Rated load duty cycles for MSD-IM and MSD-SRM

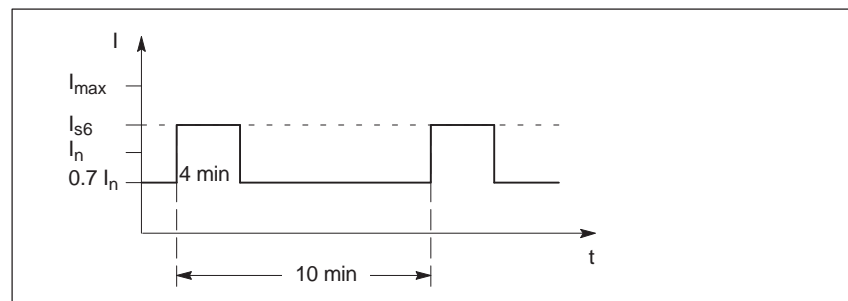

Fig. 5-4 S6 load cycle with pre-load condition

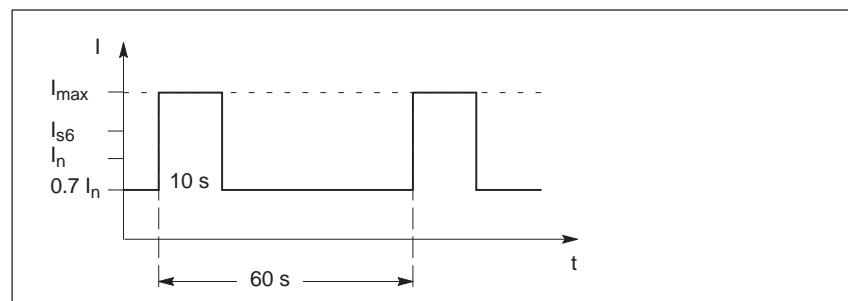

Fig. 5-5 S6 peak-current load cycle with pre-load condition



## 5.4 Current reduction/derating

The current has to be reduced if one or more of the following limitations/secondary conditions apply:

- Selected inverter pulse frequency  $f_T >$  reference frequency  $f_0$
- Installation altitude  $> 1000$  m above sea level
- Ambient temperature  $T_U > 40$  °C

---

### Notice

**The currents must be reduced for  $I_n$ ,  $I_{s6}$  and  $I_{max}$  in the same way.**

All of the relevant limitations/secondary conditions must be taken into account with an appropriate reduction factor (refer to the calculation example, Chapter 5.4.4).

---

### 5.4.1 Pulse frequency power modules

The current should be reduced from the reference frequency  $f_0$  onwards according to the following rule:

$$X_T = 100\% - \frac{(100\% - X_L) \cdot (f - f_0)}{8 \text{ kHz} - f_0}$$

#### Definitions

The pulse frequency of the power modules (inverters) must be at least factor 5 for the maximum motor frequency!

- $f_0$  Pulse frequency reference frequency in accordance with the technical data
- $f$  set inverter pulse frequency
- $T_U$  ambient temperature
- $X_L$  power module-specific derating factor for the inverter pulse frequency
- $X_T$  derating factor for the inverter pulse frequency
- $X_H$  derating factor for the ambient temperature
- $X_{TU}$  derating factor for the installation altitude as a %

#### Calculation example

See Chapter 5.4.4

**Pulse frequency–dependent derating**

Factor  $X_T$ , diagram only for illustration, calculation example in Chapter 5.4.4.

- for MSD–IM and MSD–SRM or IM operation (sensorless)

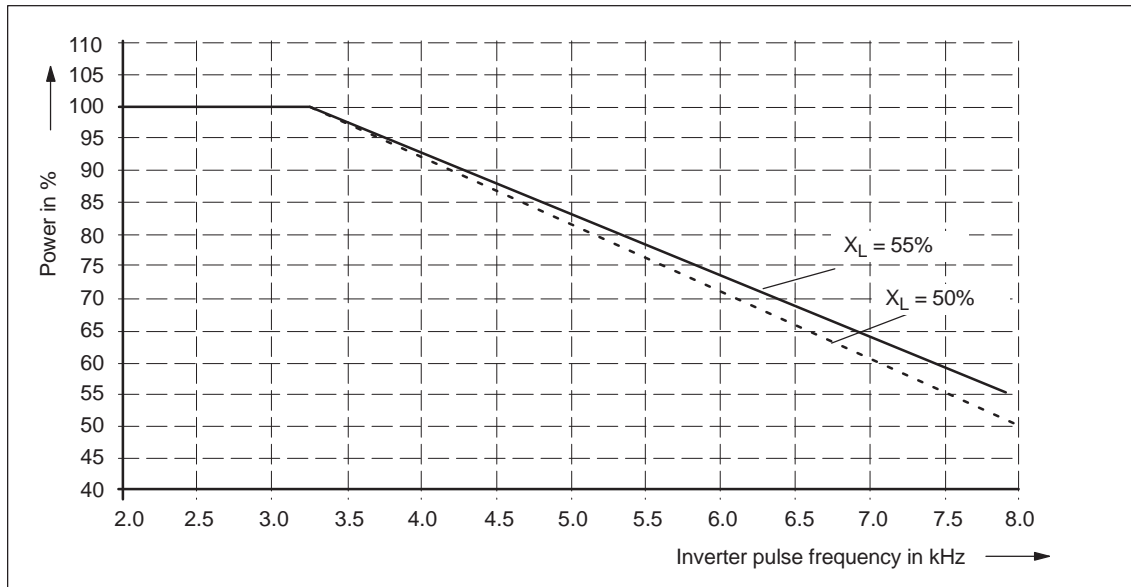

Fig. 5-6 Power as a function of the inverter pulse frequency for MSD-IM and MSD-RSM

- for FD

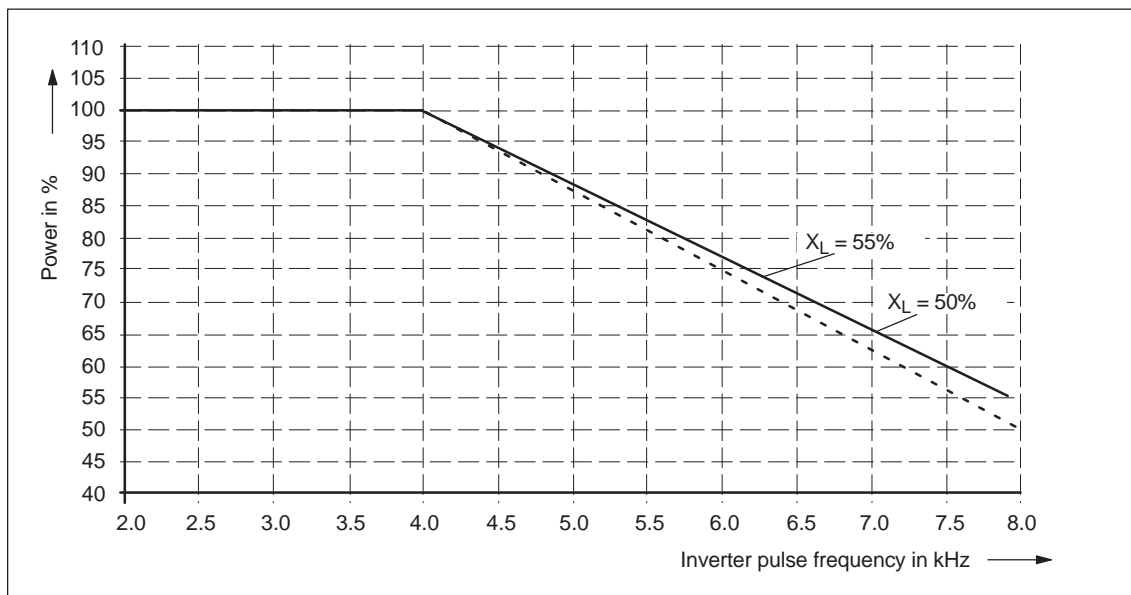

Fig. 5-7 Power as a function of the inverter pulse frequency for FD

5.4 Current reduction/derating

5.4.2 Temperature-dependent derating

For an ambient temperature  $T > 40\text{ °C}$ , derating is required according to the following rule:

$$X_{TU} = 100\% - 2.5\% (T_U - 40\text{ °C})$$

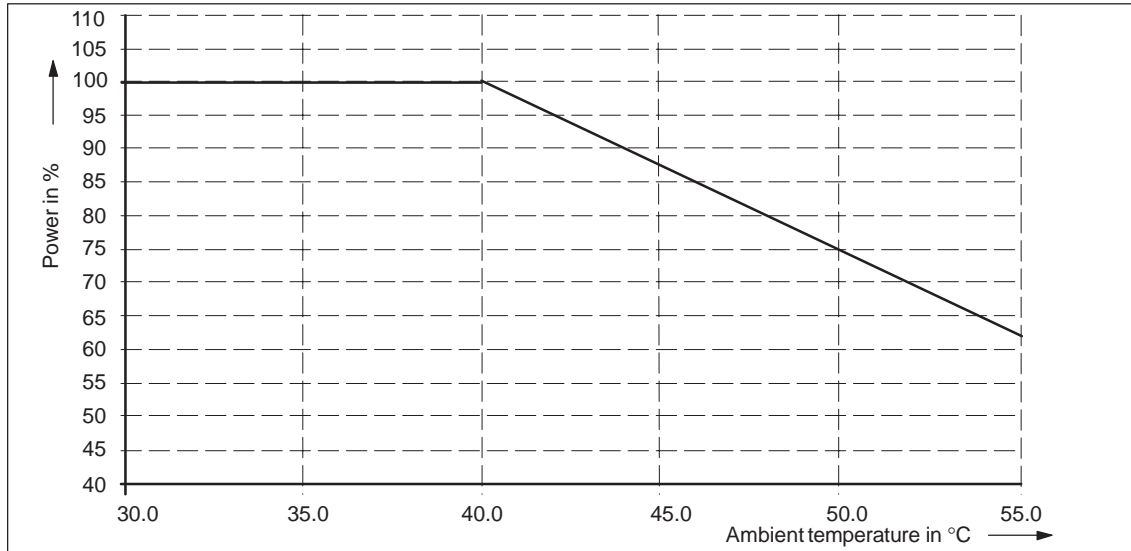

Fig. 5-8 Power as a function of the temperature

**Notice**

The maximum ambient temperature for operation of  $T_U = 55\text{ °C}$  may not be exceeded.

5.4.3 Installation height-dependent derating

For an installation altitude  $h > 1000\text{ m}$  above sea level, derating is required according to the following derating characteristic:

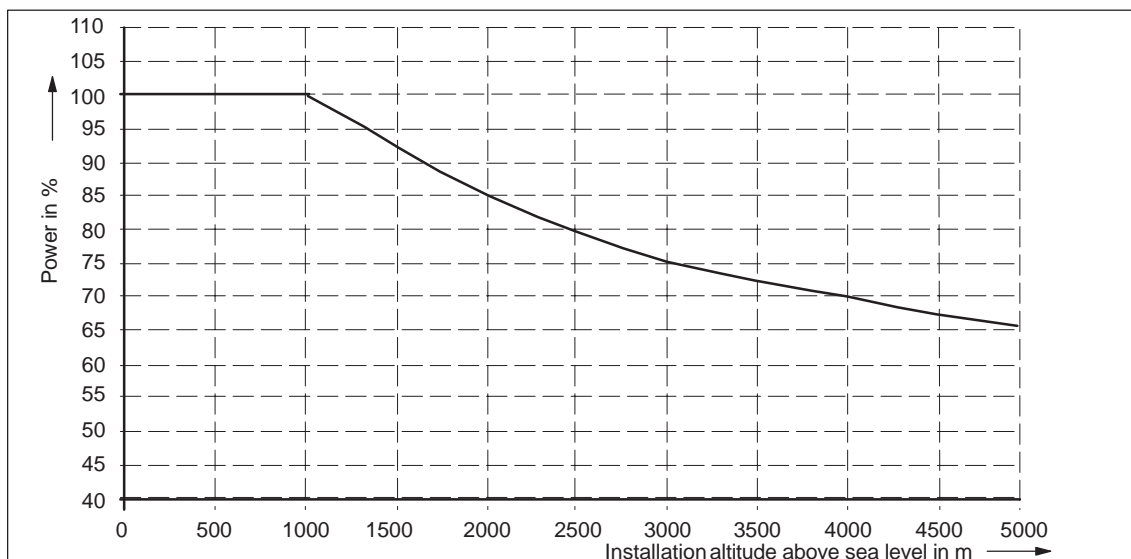

Fig. 5-9 Power relative to the installation altitude

### 5.4.4 Calculation examples

#### Temperature/ installation altitude derating

- Supplementary conditions

Power module: 6SN1123-1AA0□-0EA1

Operating mode: FD

Inverter pulse frequency: 6.3 kHz

Installation altitude 2000 m above sea level

Ambient temperature 45 °C

$$X_L = 55\%$$

$$f_0 = 4.0 \text{ kHz}$$

$$I_N = 56 \text{ A}$$

$$I_{\max} = 112 \text{ A}$$

- Determining the derating factors

$$X_T = 100\% - \frac{(100\% - 55\%) \cdot (6.3 \text{ kHz} - 4.0 \text{ kHz})}{8.0 \text{ kHz} - 4.0 \text{ kHz}} = 74.125\%$$

$$X_{TU} = 100\% - 2.5\% \cdot (45 \text{ °C} - 40 \text{ °C}) = 87.5\%$$

$$X_H \approx 85\%$$

- Calculating the permissible current values

$$I_{N\text{red}} = I_N \cdot X_T \cdot X_{TU} \cdot X_H = 56 \text{ A} \cdot 0.74125 \cdot 0.875 \cdot 0.85 = 30.8 \text{ A}$$

$$I_{\max\text{red}} = I_{\max} \cdot X_T \cdot X_{TU} \cdot X_H = 112 \text{ A} \cdot 0.74125 \cdot 0.875 \cdot 0.85 = 61.7 \text{ A}$$

#### Current reduction

Power module: 6SN1123-1AA0□-0EA1

Operating mode: FD

Inverter pulse frequency: 6.3 kHz

Installation altitude <1000 m above sea level

Ambient temperature <40 °C

$$X_L = 55\%$$

$$f_0 = 4.0 \text{ kHz}$$

$$I_N = 56 \text{ A}$$

$$I_{\max} = 112 \text{ A}$$

$$X_T = 100\% - \frac{(100\% - 55\%) \cdot (6.3 \text{ kHz} - 4.0 \text{ kHz})}{8.0 \text{ kHz} - 4.0 \text{ kHz}} = 74.125\%$$

$$\Rightarrow I_{N6.3} = I_N \cdot X_T = 56 \text{ A} \cdot 0.74125 = 41.5 \text{ A}$$

$$\Rightarrow I_{\max 6.3} = I_{\max} \cdot X_T = 112 \text{ A} \cdot 0.74125 = 83.0 \text{ A}$$

---

### 5.4 Current reduction/derating

#### Derating example

- Installation altitude: e.g. Puebla, Mexico, 2200 m above sea level  
Derating to 83%  $I_N$  necessary!
- Temperature: e.g. internal temperature of the switchgear cabinet with 45 °C,  
no air-conditioner  
Derating to 87%  $I_N$  necessary!
- Power module clock cycle frequency 6SN1123-1AA0-0EA2  
 $X_L = 50\%$ : e.g. for a 6.3 kHz spindle application  
Derating to 68%  $I_N$  necessary!

Result:

Derating for the power unit to:

$83\% \cdot 87\% \cdot 68\% \approx 50\% I_N$  required!

Derating for the line supply infeed to:

$83\% \cdot 87\% \approx 72\% I_N$  required!

Table 5-3 Power modules in a 1-axis version, derating for MSD-SRM or IM operation (sensorless)

6SN112□-1AA□-		0HA□	0AA□	0BA□	0CA□	0DA□	0LA□	0EA□	0FA□	0JA□	0KA□
Type of cooling		Non-ventilated		Fan							
Inverter pulse frequency $f_T = 4.0$ kHz											
Rated current $I_N$	A	2.8	4.6	7.3	22.0	27.8	41.6	55.0	77.9	111.0	185.0
Current for S6-40% $I_{S6-40\%}$	A	2.8	4.6	9.2	29.3	37.0	55.5	73.3	100.8	138.8	231.3
Peak current $I_{max}$	A	2.8	7.3	14.7	29.3	47.2	70.3	93.5	116.4	178.5	237.7
Inverter pulse frequency $f_T = 5.33$ kHz											
Rated current $I_N$	A	2.3	3.9	6.2	18.7	24.0	36.0	46.7	66.1	96.0	160.1
Current for S6-40% $I_{S6-40\%}$	A	2.3	3.9	7.8	24.9	32.0	48.0	62.3	85.6	120.0	200.1
Peak current $I_{max}$	A	2.3	6.2	12.5	24.9	40.8	60.8	79.4	98.8	154.5	205.7
Inverter pulse frequency $f_T = 6.4$ kHz											
Rated current $I_N$	A	2.0	3.3	5.3	16.0	21.0	31.5	40.0	56.7	84.0	140.0
Current for S6-40% $I_{S6-40\%}$	A	2.0	3.3	6.7	21.3	28.0	42.0	53.3	73.3	105.0	175.0
Peak current $I_{max}$	A	2.0	5.3	10.7	21.3	35.7	53.2	68.0	84.7	135.1	179.9
Inverter pulse frequency $f_T = 8.0$ kHz											
Rated current $I_N$	A	1.5	2.5	4.0	12.0	16.5	24.8	30.0	42.5	66.0	110.0
Current for S6-40% $I_{S6-40\%}$	A	1.5	2.5	5.0	16.0	22.0	33.0	40.0	55.0	82.5	137.5
Peak current $I_{max}$	A	1.5	4.0	8.0	16.0	28.1	41.8	51.0	63.5	106.2	141.4

Table 5-4 Power modules in a 2-axis version, derating for MSD-SRM

6SN112□-1AB00-		0HA□	0AA□	0BA□	0CA□
Type of cooling		Fan			
Inverter pulse frequency $f_T = 4.0$ kHz					
Rated current $I_N$	A	2.8	4.6	7.4	22.2
Current for S6-40% $I_{S6-40\%}$	A	2.8	4.6	9.3	29.6
Peak current $I_{max}$	A	2.8	7.4	14.8	29.6
Inverter pulse frequency $f_T = 5.33$ kHz					
Rated current $I_N$	A	2.4	4.0	6.4	19.2
Current for S6-40% $I_{S6-40\%}$	A	2.4	4.0	8.0	25.6
Peak current $I_{max}$	A	2.4	6.4	12.8	25.6
Inverter pulse frequency $f_T = 6.4$ kHz					
Rated current $I_N$	A	2.1	3.5	5.6	16.8
Current for S6-40% $I_{S6-40\%}$	A	2.1	3.5	7.0	22.4
Peak current $I_{max}$	A	2.1	5.6	11.2	22.4
Inverter pulse frequency $f_T = 8.0$ kHz					
Rated current $I_N$	A	1.65	2.75	4.4	13.2
Current for S6-40% $I_{S6-40\%}$	A	1.65	2.75	5.5	17.6
Peak current $I_{max}$	A	1.65	4.4	8.8	17.6

## 5.5 Operating power modules from an unregulated infeed

The drive modules can be operated from both unregulated and regulated supply modules belonging to the SIMODRIVE 611 drive converter system. The engineering and power data of this Configuration Manual refer to operation with the regulated infeed/regenerative feedback modules. This data should be corrected, if required, when operated from unregulated infeed modules.

### Operating drive modules with PH and 1FE1 motors and induction motors from an unregulated infeed

When operation is with an unregulated infeed (e.g. UI module or unregulated operated I/R module), a lower maximum motor output is available in the upper speed range than with the use of the infeed/regenerative feedback module.

As a result of the low DC link voltage of 490 V (for a line supply infeed with 400 V 3-ph. – 10%) for the UI module or unregulated operated I/R module, the available continuous output is given by:

If

$$\frac{U_{ZK}}{1.5 \times V_{N \text{ motor}}} < 1$$

then, only the following continuous power is available

$$P_{\text{continuous}} = P_N \cdot \frac{U_{ZK}}{1.5 \times V_{N \text{ motor}}}$$

$U_{\text{DC link}} = \text{line voltage} \cdot 1,35$   
 $U_{\text{DC link}} = 436 \text{ V}$   
 for 360 V –10 % line voltage  
 $U_{\text{DC link}} = 486 \text{ V}$   
 for 400 V –10 % line voltage

$V_{N \text{ motor}}$  should, for the particular motor, be taken from the appropriate documentation (refer to Appendix, References).

As a result of the lower DC link voltage, it is possible that motor rated speeds will no longer be able to be reached, refer to Engineering the motors. In this case, the speed of the motors, and therefore the power, must be appropriately reduced.

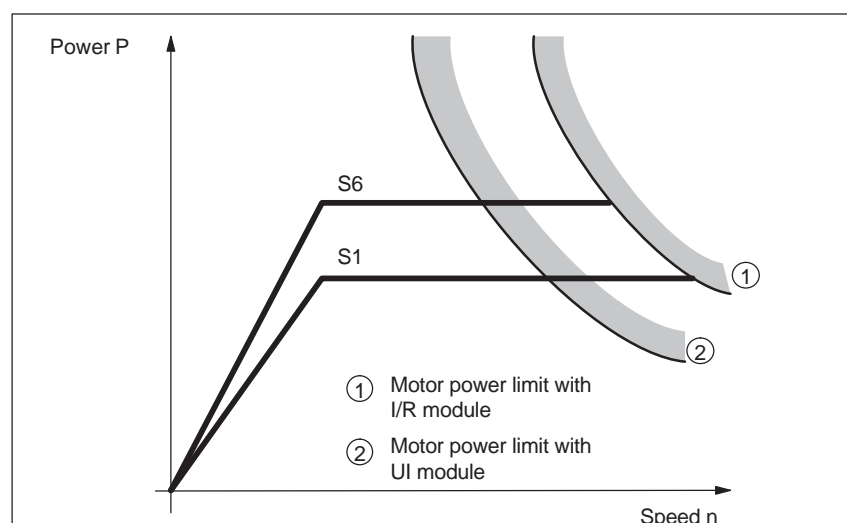

Fig. 5-10 Speed/power graph

**Reader's note**

Selecting the power rating for UI modules, refer to Chapter 6.7.5.

For the 28 kW UI, the pulsed resistors must be separately ordered and externally mounted.

For higher regenerative feedback powers, a separate braking resistor module must be provided or the regenerative power reduced by using longer braking times.

**Operating drive modules with 1FT6, 1FK and 1FN motors on uncontrolled infeeds**

As a result of the lower DC link voltage of 490 V<sup>1)</sup> for the UI module (600 V for the I/R module), under certain circumstances, the following restrictions must be expected:

- Reduction of the dynamic drive properties in the upper speed/velocity range
- Lower utilization of the rated motor speed/velocity if the requirement relating to overload is kept

---

1) For a line supply infeed with 3-ph. 400 V AC –10%.



## 5.6 Interfaces and terminals

### 5.6.1 Interface overview

Table 5-5 1-axis module



Term. no.	Designation	Function	Type 1)	Typ. voltage/limit values	Max. cross-section
U2 V2 W2	A1	Motor connection	O	3-ph. 430 V AC	See Chapter 5.6.2
PE		Protective conductor Protective conductor		0 V 0 V	2 screws
P600 M600		DC link DC link	I/O I/O	+300 V -300 V	Busbar Busbar

Table 5-6 2-axis module

Term. no.	Designation	Function	Type 1)	Typ. voltage/limit values	Max. cross-section
U2 V2 W2	A1	Motor connection for axis 1	O	3-ph. 430 V AC	See Chapter 5.6.2
U2 V2 W2	A2	Motor connection for axis 2	O	3-ph. 430 V AC	See Chapter 5.6.2
PE		Protective conductor		0 V	2 screws
P600 M600		DC link DC link	I/O I/O	+300 V -300 V	Busbar Busbar

1) O = Output; I = Input

#### Note

For 2-axis module, Order No.: 6SN1123-1AB00-0CA2/0CA3, note that the terminal arrangement of A1 and A2 differs compared to the other 2-axis modules!

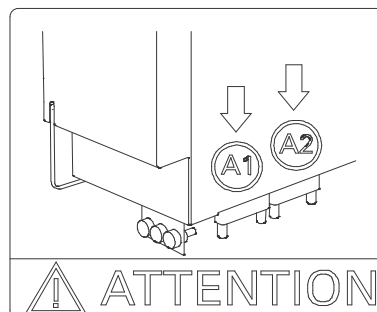

## 5.6.2 Connectable cable cross-sections

The cable cross-sections that can be connected are listed in Table 5-7:

Table 5-7 Cable cross-sections that can be connected at the power module (motor connection)

MLFB		Connection cross-section [mm <sup>2</sup> ]													1)	2)
		1,5	2,5	4	6	10	16	25	35	50	70	95	120	150		[Nm]
6SN112□-1AA00-0KA□	400 A													X	M6	25...30
6SN112□-1AA00-0JA□	300 A													X	M6	15...20
6SN112□-1AA01-0FA□	200 A													X	M6	15...20
6SN1123-1AA02-0FA□	200 A													X	M6	15...20
6SN112□-1AA00-0EA□	160 A													X	M6	6...8
6SN112□-1AA00-0LA□	108 A													X	M6	6...8
6SN1123-1AA00-0DA□	80 A					X									M5	1,5...1,8
6SN112□-1AA00-0CA□	50 A	X	X	X	X										M5	0,7...0,8
6SN112□-1AA00-0BA□	25 A	X	X	X	X										M5	0,7...0,8
6SN112□-1AA00-0AA□	15 A	X	X	X	X										M5	0,7...0,8
6SN112□-1AA00-0HA□	8 A	X	X	X	X										M5	0,7...0,8
6SN112□-1AB00-0CA□	2x50 A	X	X	X	X										M5	0,7...0,8
6SN1123-1AB00-0BA□	2x25 A	X	X	X	X										M5	0,7...0,8
6SN112□-1AB00-0AA□	2x15 A	X	X	X	X										M5	0,7...0,8
6SN1123-1AB00-0HA□	2x8 A	X	X	X	X										M5	0,7...0,8
Key		Terminal area for flexible cable with end sleeves (with or without plastic collars)														
		Terminal area for flexible cables with terminal pin														
	X	IP20 is guaranteed when correctly used, e.g. insulated pin-type cable lugs														

- 1) Size of the screw for the protective conductor connection
- 2) Tightening torque of the terminals or connectors



### Warning

The internal overload monitoring function of the power modules only protects the cable if this is dimensioned/selected corresponding to the power module currents. If smaller cross-sections are selected, then the user must ensure the appropriate level of cable protection, e.g. by suitably setting the control parameters.

### Note

For UL certification, only use copper cables that have been appropriately dimensioned/selected for the operating temperature  $\geq 60$  °C.

## 5.6 Interfaces and terminals

**Note**

In order to clearly indicate potential hazards due to voltages at the terminals, the warning plate WS-2K (Order No. 1004513) can be ordered at the following address.

Phoenix Contact GmbH & Co. KG  
 Flachmarktstr. 8  
 32825 Blomberg  
 Germany  
 Tel. +49 5235 3 00  
 Fax +49 5235 3 1200  
<http://www.phoenixcontact.com>

**Reader's note**

For a description of DC link terminal adapter for two-tier configuration, see the dimension drawing in Fig. 12-60.

### 5.6.3 Motor terminals A1 and A2

The arrangement of the motor terminals A1/A2 can be taken from Table 5-8, diagrams 5-11 and 5-12

Table 5-8 Motor terminals A1 and A2 provided at the power module

MLFB		Device	A1	A2
6SN112□-1AA00-0KA□	400 A	1	Axis 1	-
6SN112□-1AA00-0JA□	300 A			
6SN112□-1AA01-0FA□	200 A			
6SN1123-1AA02-0FA□	200 A			
6SN112□-1AA00-0EA□	160 A	2	Axis 1	-
6SN112□-1AA00-0LA□	108 A			
6SN1123-1AA00-0DA□	80 A	3	Axis 1	-
6SN1123-1AB00-0CA□	2x50 A int.	4	Axis 1	Axis 2
6SN1124-1AB00-0CA□	2x50 A ext.	5	Axis 1	Axis 2
6SN1124-1AA00-0CA□	50 A	6	-	Axis 1
6SN1123-1AB00-0BA□	2x25 A	7	Axis 1	Axis 2
6SN112□-1AB00-0AA□	2x15 A			
6SN1123-1AB00-0HA□	2x8 A			
6SN112□-1AA00-0BA□	25 A	8	Axis 1	-
6SN112□-1AA00-0AA□	15 A			
6SN112□-1AA00-0HA□	8 A			

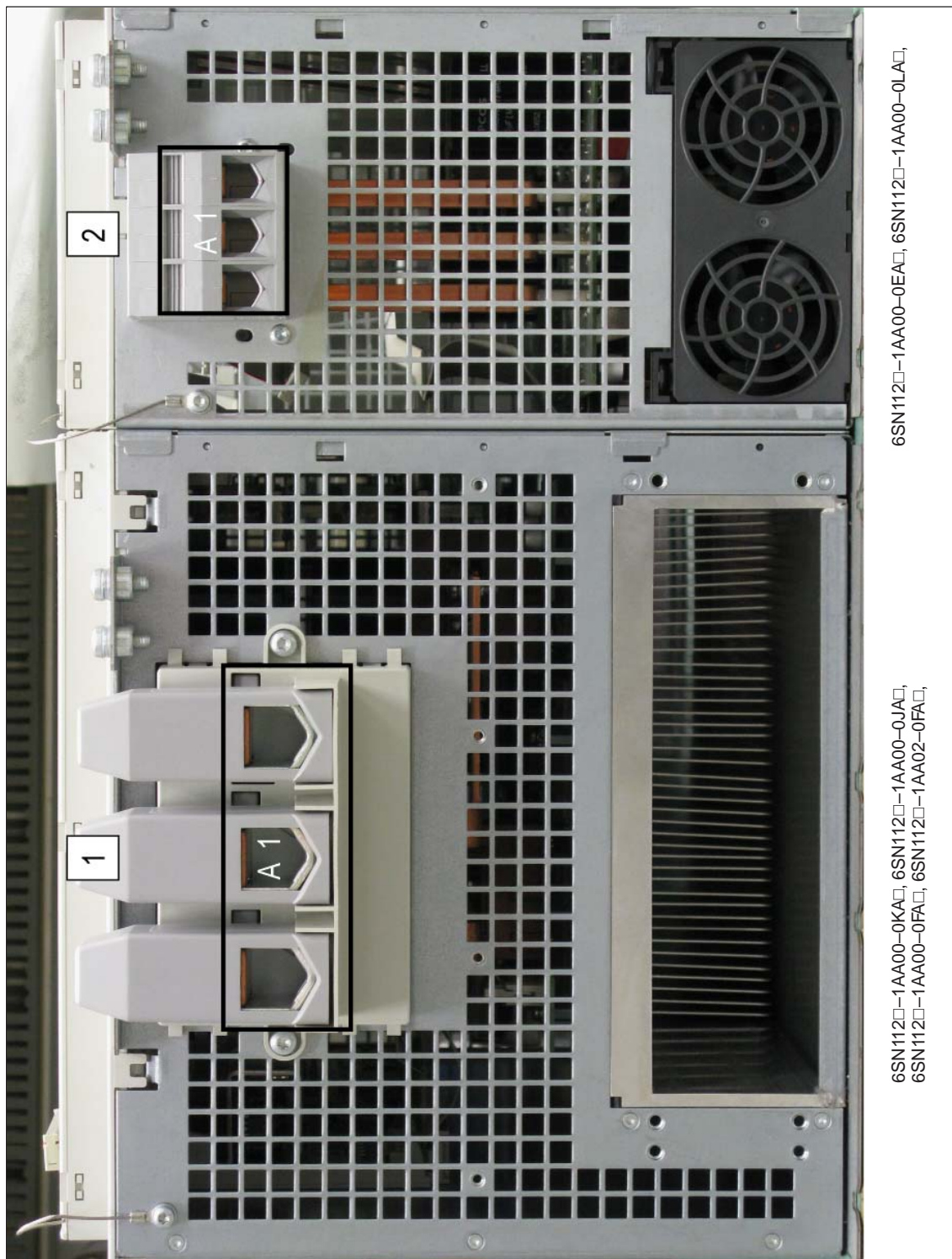

Fig. 5-11 Power Modules device 1 und 2

5.6 Interfaces and terminals

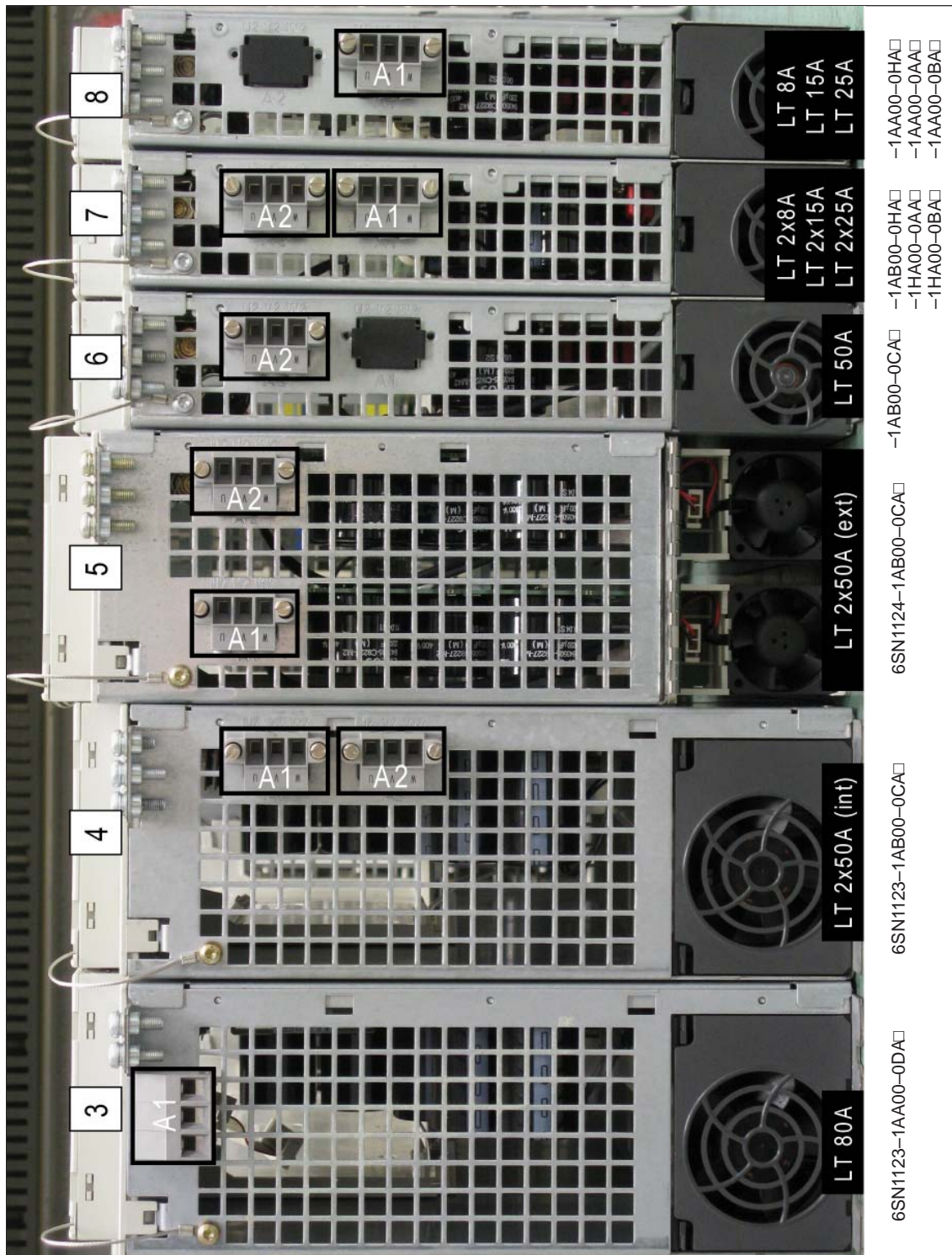

Fig. 5-12 Power Modules devices 2 ... 8



## Infeed Modules

### 6.1 Description

#### General information

The infeed modules are used to connect the drive group to the line supply. The infeed/regenerative feedback module (I/R module) and the module for the unregulated infeed (UI module) are used to input power into the DC link. Further, the I/R, UI, and the monitoring module also provide the electronics power supply for the connected modules.

The infeed modules do not have any comprehensive overload protection. Such overload protection must be provided by the configuration and correct setting of the current values in the control boards.

#### UI module

For the UI module, when the motor brakes, the drive energy injected into the DC link is converted into heat in the braking resistors and dissipated to the environment. These braking resistors are either integrated or mounted. When required, one or more additional pulsed resistor modules (PR modules) can be used within the limits specified when engineering the system.

This module is used for the following applications:

- Machines with few or short braking cycles, low braking energy
- Drive groups with limited dynamic demands, in particular for the main spindle drive

#### I/R module with HFD reactor

I/R modules and HF/HFD commutating reactors form the step-up converter (7 kHz) for controlling the DC link voltage and enabling a regenerative feedback. This module is used for the following applications:

- Machines with high dynamic requirements placed on the drives
- Frequent braking cycles and high braking energy
- Control cabinet designs optimized for low operating costs

---

#### Note

The HFD line reactor is required in order that the I/R module can function, as this is cyclically short-circuited for the step-up controller, voltage control function to be active!

---

#### Overvoltage limiting module

The overvoltage limiting module limits sporadic, transient overvoltages, for example that can occur as a result of switching operations in the line supply.

## 6.1 Description

**Monitoring module** The monitoring module contains a complete electronics power supply for the equipment bus and the central monitoring functions for a separate drive group. The power is normally supplied from the 3-ph. 400 to 480 V AC line supply. For emergency retraction in case of a power failure, the power supply can also be connected to the DC link in parallel (see Section 8.15).

The monitoring module is required if a higher number of drive modules in a group exceeds the electronics power supply of the infeed module (I/R or UI module). The monitoring module also allows groups of drive modules to be created in multiple cabinet compartments or tiers.

**Arrangement**

The I/R, UI and monitoring module are located as the first module at the left in the drive group.

The mounting surface for the line supply infeed and drive modules as well as the commutating reactors and line filter must be mounted to the mounting panels through a low-resistance connection (e.g. galvanized plates and panels).

Line filters, line filter modules and shielded cables are available in order to comply with the CE requirements regarding the radio interference voltage limit values.

Shield terminal plates are available to meet EMC requirements when using shielded power cables.

**Operating conditions**

$$\text{Number of charge operations within 8 min} \leq \frac{\text{Charge limit, infeed module } [\mu\text{F}]}{\Sigma \text{ DC link capacitance of the drive group } [\mu\text{F}]}$$

Fig. 6-1 DC link pre-charging frequency

**Note**

In the "standby mode" of the line supply infeed, pulse inhibit for the power modules, terminal 63 should also be used to inhibit the pulses in the infeed. The DC link remains at the non-regulated level; this means that when the pulses are enabled, it is immediately regulated and is ready to operate.

The cycle indicated above also applies to the starting frequency of the power supply (from the line supply or X181).

The maximum starting frequency for the power supply is five times within a five minute period.

**Notice**

Failure to comply with this boundary condition triggers a thermal protection in the device, preventing further startup of the power supply.

Consequence: All LEDs remain dark.

Remedy: Switch off the power and wait at least two minutes before switching on the power again. For a 6-conductor connection, it is sufficient to interrupt the power supply for two minutes at connector X181.

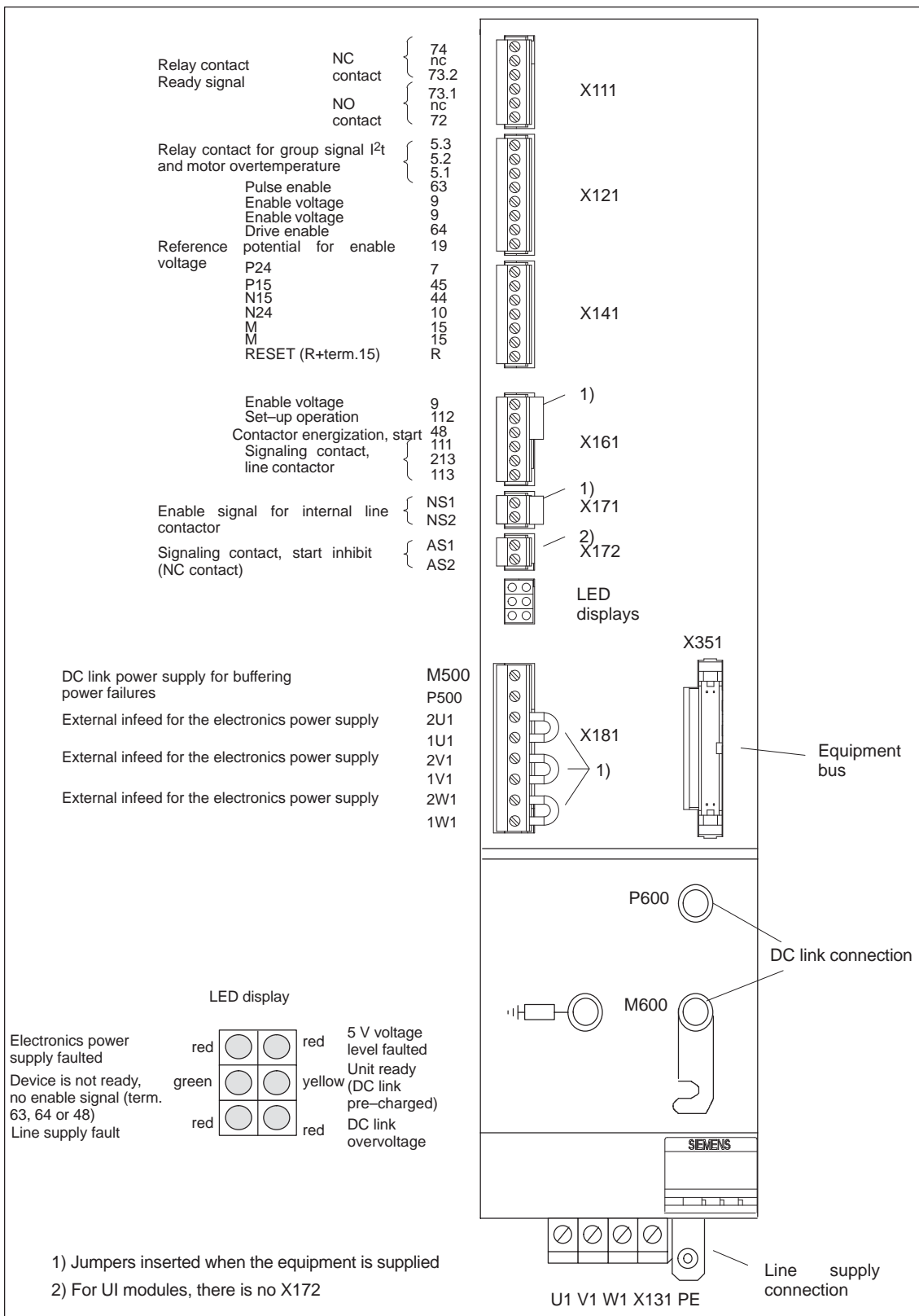

Fig. 6-2 Interfaces, infeed module (UI module) or infeed/regenerative feedback module (16 to 55 kW I/R module)



6.1 Description

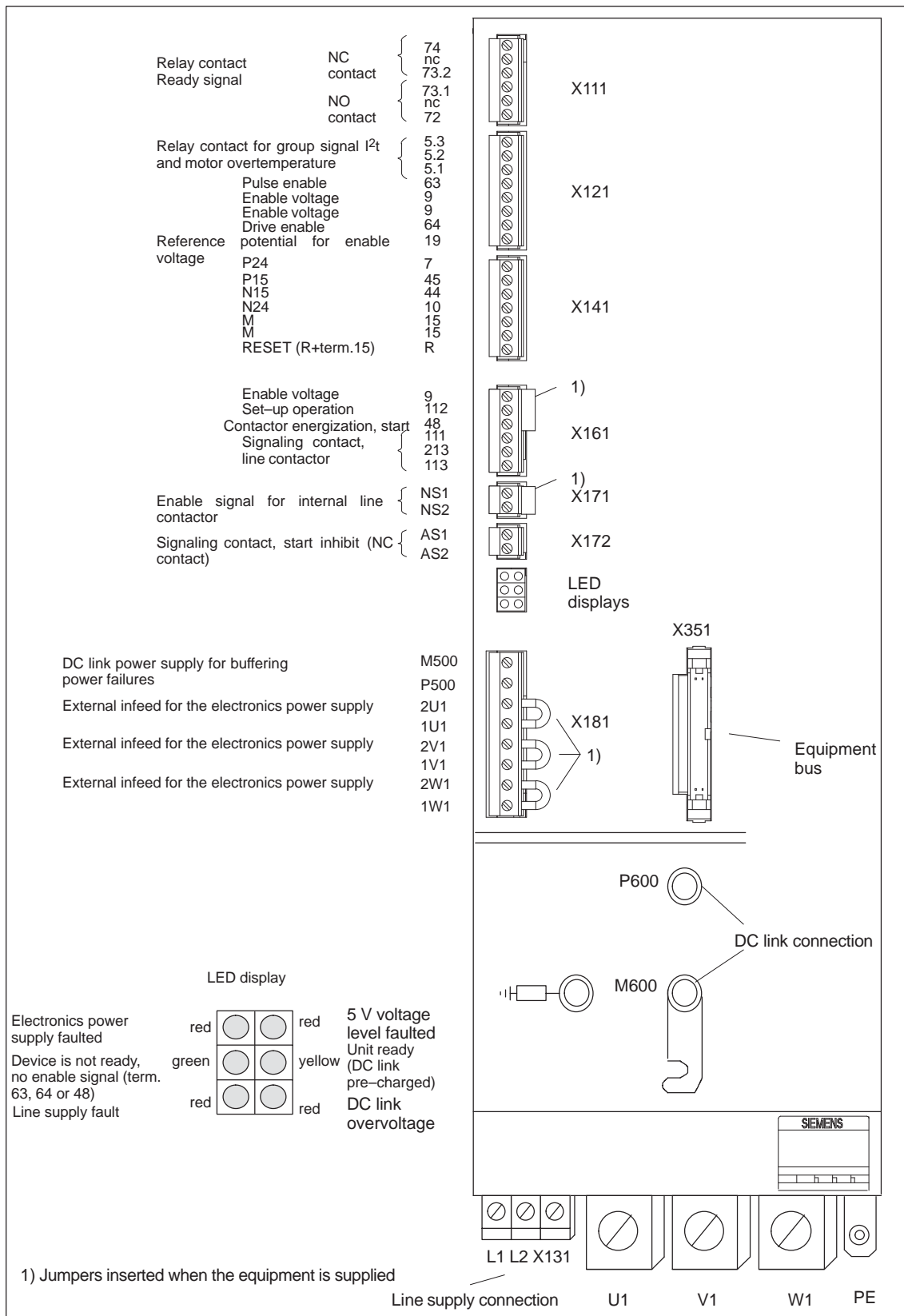

Fig. 6-3 Infeed/regenerative feedback module (80 and 120 kW I/R module) interfaces

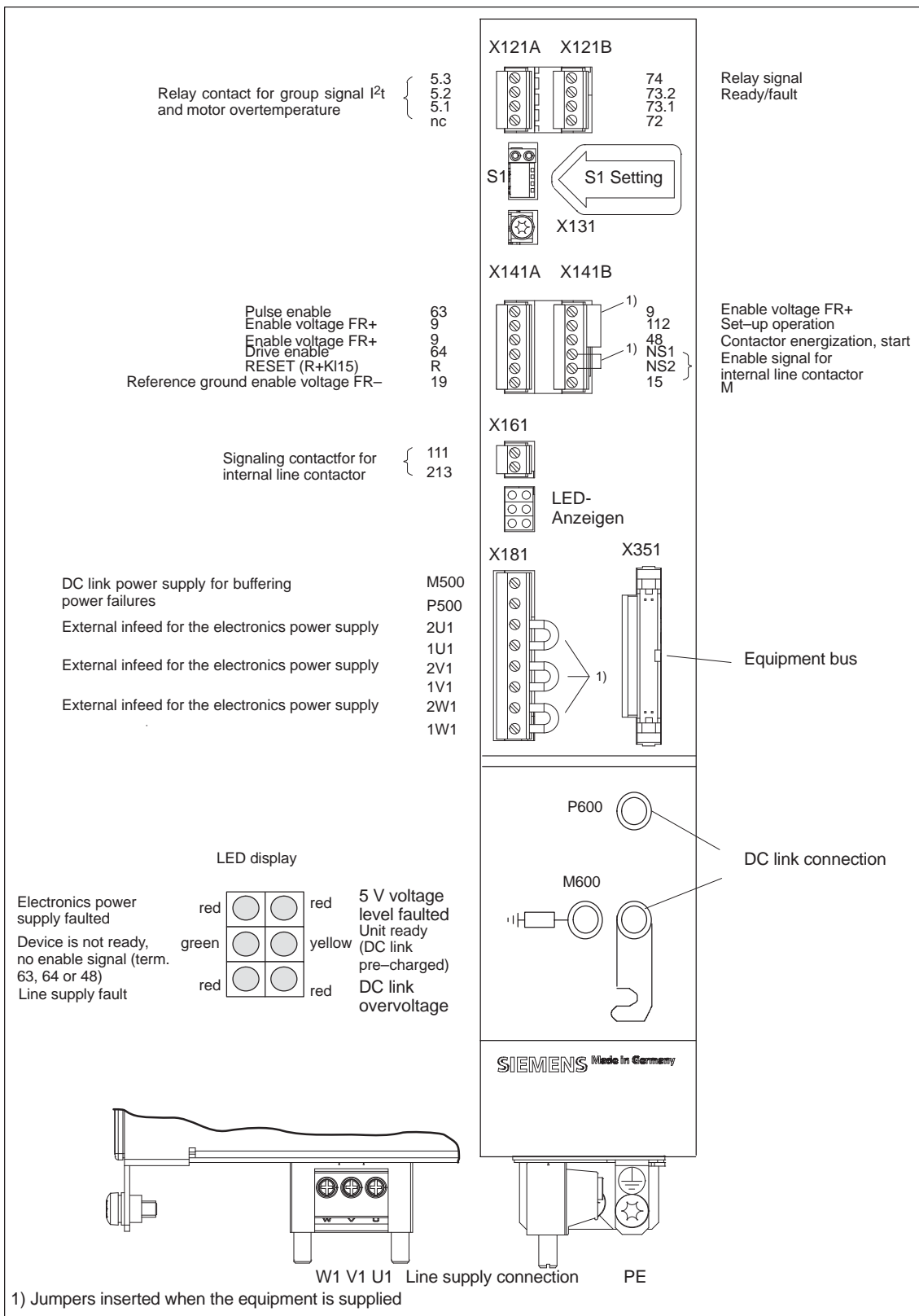

Fig. 6-4 Infeed module 5 kW UI module interfaces

6.1 Description

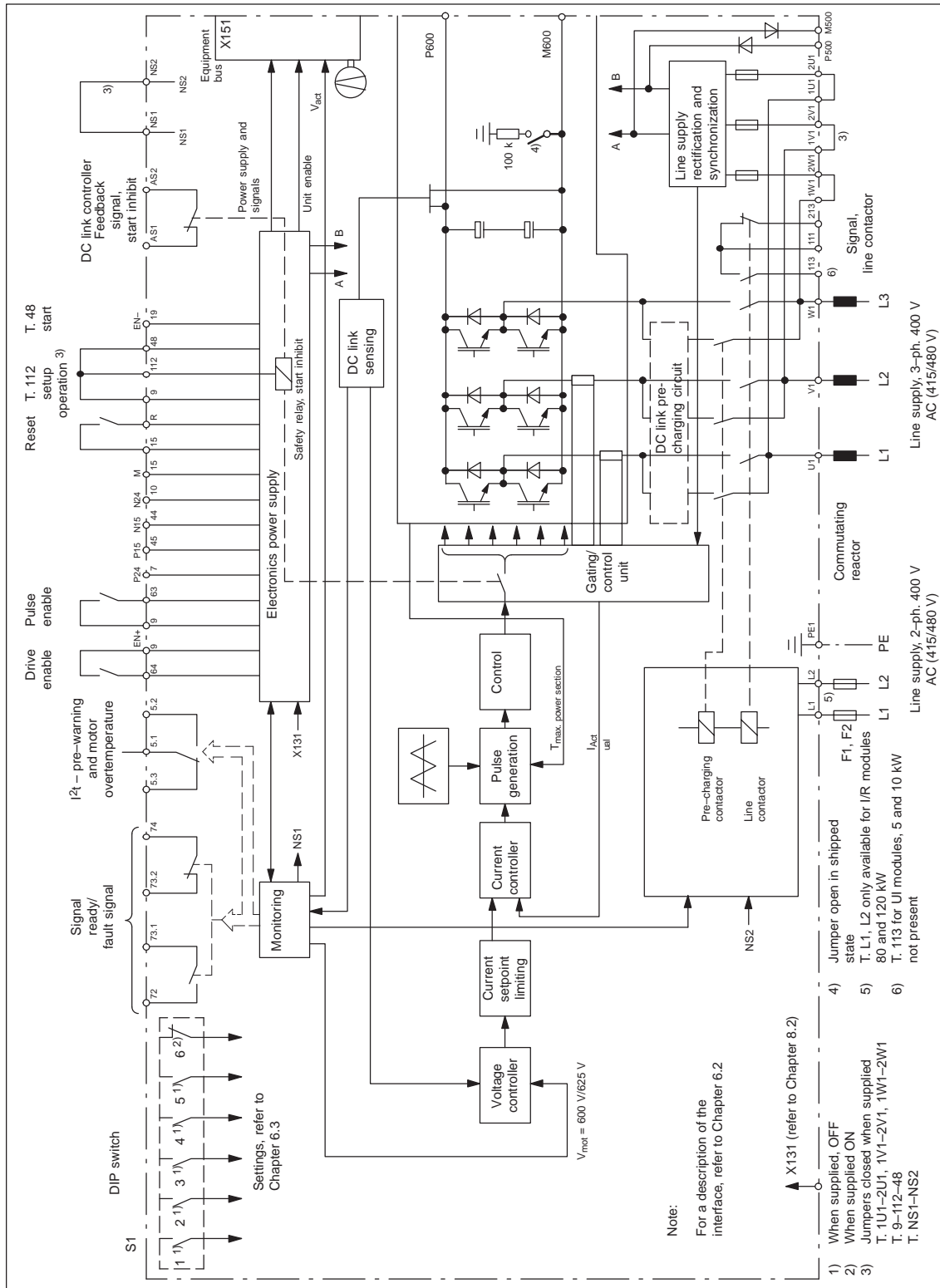

Fig. 6-5 Block diagram, line supply infeed module (I/R)

## 6.2 Interface overview



### Danger

Protection from direct contact by means of SELV/PELV is permitted only in areas with equipotential bonding and in dry interior spaces. If these conditions are not given, other protective measures against electric shock must be taken, e.g. protection through protective impedances or limited voltage or by implementing protection class I and II.

Only PELV or SELV voltages may be connected at terminals with either PELV or SELV voltages (refer to EN 60204–1, Section 6.4).

For Order Nos. for coding connectors, refer to Catalog NC60.

Refer to the information in the following tables.

### 6.2.1 Interface overview, NE modules

The interface description applies to all NE modules except for the 5 kW UI module. The interface of the 5 kW UI module has a separate description (see Section 6.2.2).

Table 6-1 Interface description for NE modules

Term. No.	Designation	Function	Type 1)	Typ. voltage/limit values for $V_n$ 400 V	Max. cross-section <sup>10)</sup>	Terminals provided on <sup>3)</sup>
U1, V1 W1		Line supply connection	I	3-ph. 400 V AC	refer to Section 4.2	I/R, UI
L1 L2		Line supply connection for contactor	I I	refer to Section C.1.3, Table 3.5 refer to Chapter 6.2.5, L1, L2	16 mm <sup>2</sup> /10 mm <sup>2</sup> 4) 16 mm <sup>2</sup> /10 mm <sup>2</sup> 4)	I/R 80 kW, 120 kW
PE P600 M600		Protective conductor DC link DC link	I I/O I/O	0 V +300 V –300 V	Screw Busbar Busbar	I/R, UI, monitoring module
		Grounding bar <sup>5)</sup>	I/O	–300 V	Conductor bar	I/R, UI

- 1) I = input; O = output; NC = NC contact; NO = NO contact; (for signal, NO = high; NC = low)  
P = only for PELV voltage; S = only for SELV voltage
- 2) Term. 19 is the reference ground (connected through 10 kΩ to the general reference ground X131/T.15 inside the module)  
Terminal 15 must not be connected to PE, to terminal 19 or to external voltage sources.  
Terminal 19 can be connected with X131.  
The terminal may be used only for enabling the associated drive group.
- 3) I/R = infeed/regenerative feedback module; UI = unregulated infeed; MM = monitoring module;  
PR = pulsed resistor module
- 4) The first data applies with pin-type cable lug. The second data is used for finely-stranded cable without end sleeve.
- 5) The grounding clip is used to ground the DC link M600 busbar through 100 kΩ (must be closed and must not be closed if RCCBs are used, see also Chapter 8.1;  
the grounding clip must be opened if the system is subject to a high-voltage test).
- 6) RESET = resets the fault memory, edge-triggered for the complete drive group (terminal "R" → Terminal 15 = RESET)
- 7) Terminals 111–213, positively-driven opening contacts (for I/R 16 kW and UI 10 kW, only from Order No. [MLFB]: 6SN114□–1□□01–0□□□)  
Terminals 111–113 NO contact not positively-driven  
For I/R 16 kW (from version E) and UI 10 kW (from version F) the following apply:  
Terminals 111–213, positively-driven opening contacts (series circuit of NC contact, main contactor and NC contact, pre-charging contactor)  
Terminals 111–113, positively-driven NO contacts
- 8) Max. current load of terminal 9 with respect to terminal 19: 0.5 A.
- 9) Only for UI 28 kW
- 10) For UL certification, only use copper cables dimensioned for an operating temperature  $\geq 60^\circ\text{C}$
- 11) Max. permissible connected power:  $P_{\text{max}} \leq 43 \text{ kW}$ ; max. permissible current load:  $I_{\text{max}} \leq 72 \text{ A}$
- 12) When the AS1/AS2 contacts are connected in series a contact resistance of approx. 0.20 Ohm must be taken into consideration over the lifetime of the contacts. For a 24 V switching voltage, from experience, a series circuit of up to five contacts can be used without any problems due to the non-linear contact characteristics.
- 13) In accordance with EN 60204–1 (machine safety), control transformers must be used for AC control voltages.

## 6.2 Interface overview

Table 6-1 Interface description for NE modules, continued

Term. No.	Designation	Function	Type 1)	Typ. voltage/limit values for $V_n$ 400 V	Max. cross-section <sup>10)</sup>	Terminals provided on <sup>3)</sup>	
P600 M600		DC link DC link	I/O I/O	+300 V -300 V	16 mm <sup>2</sup> /10 mm <sup>2</sup> 4) 16 mm <sup>2</sup> /10 mm <sup>2</sup> 4)	Monitoring module 11)	
1R, 2R, 3R	TR1, TR2 <sup>9)</sup>	Connection, external resistor	I/O	300 V	6 mm <sup>2</sup> /4 mm <sup>2</sup> 4)	UI 28 kW	
	X131	Electronics M	I/O	0 V	16 mm <sup>2</sup> /10 mm <sup>2</sup> 4)	I/R, UI, monitoring module	
	X151	Equipment bus	I/O	Various	Ribbon cable	I/R, UI, monitoring module	
M500 P500	X181 X181	DC link power supply DC link power supply Output L1 Input L1	I I	DC -300 V DC +300 V	1.5 mm <sup>2</sup> 1.5 mm <sup>2</sup>	I/R, UI, monitoring module	
1U1 2U1	X181 X181	Output L2 Input L2	O I	3-ph. 400 V AC 3-ph. 400 V AC	1.5 mm <sup>2</sup> 1.5 mm <sup>2</sup>		
1V1 2V1	X181 X181	Output L3 Input L3	O I	3-ph. 400 V AC 3-ph. 400 V AC	1.5 mm <sup>2</sup> 1.5 mm <sup>2</sup>		
1W1 2W1	X181 X181		I I	3-ph. 400 V AC 3-ph. 400 V AC	1.5 mm <sup>2</sup> 1.5 mm <sup>2</sup>		
7 45 44	X141 X141 X141	P24 P15 N15	O O O	+20.4...28.8 V/50 mA +15 V/10 mA -15 V/10 mA	1.5 mm <sup>2</sup> 1.5 mm <sup>2</sup> 1.5 mm <sup>2</sup>		I/R, UI, monitoring module
10 15 <sup>2)</sup> R <sup>6)</sup>	X141 X141 X141	N24 M RESET	O O I	-20.4...28.8 V/50 mA 0 V T.15/R <sub>I</sub> = 10 kΩ	1.5 mm <sup>2</sup> 1.5 mm <sup>2</sup> 1.5 mm <sup>2</sup>		
5.3 5.2 5.1	X121 X121 X121	} Relay contact Group signal I <sup>2</sup> t/motor temp.	NC NO I	DC 50 V/0.5 A/12 VA max DC 5 V/3 mA min	1.5 mm <sup>2</sup> 1.5 mm <sup>2</sup> 1.5 mm <sup>2</sup>		
63 <sup>2)</sup> 92 <sup>8)</sup>	X121 X121		Pulse enable Enable voltage	I O	+13 V...30 V/R <sub>E</sub> = 1.5 kΩ +24 V	1.5 mm <sup>2</sup> 1.5 mm <sup>2</sup>	
92 <sup>8)</sup> 64 <sup>2)</sup>	X121 X121		Enable voltage Drive enable	O I	+24 V +13 V...30 V/R <sub>E</sub> = 1.5 kΩ	1.5 mm <sup>2</sup> 1.5 mm <sup>2</sup>	
19	X121		Enable voltage reference potential	I	0 V	1.5 mm <sup>2</sup>	

- I = input; O = output; NC = NC contact; NO = NO contact; (for signal, NO = high; NC = low)  
P = only for PELV voltage; S = only for SELV voltage
- Term. 19 is the reference ground (connected through 10 kΩ to the general reference ground X131/T.15 inside the module)  
Terminal 15 must not be connected to PE, to terminal 19 or to external voltage sources.  
Terminal 19 can be connected with X131.  
The terminal may be used only for enabling the associated drive group.
- I/R = infeed/regenerative feedback module; UI = unregulated infeed; MM = monitoring module;  
PR = pulsed resistor module
- The first data applies with pin-type cable lug. The second data is used for finely-stranded cable without end sleeve.
- The grounding clip is used to ground the DC link M600 busbar through 100 kΩ (must be closed and must not be closed if RCCBs are used, see also Chapter 8.1;  
the grounding clip must be opened if the system is subject to a high-voltage test).
- RESET = resets the fault memory, edge-triggered for the complete drive group (terminal "R" → Terminal 15 = RESET)
- Terminals 111–213, positively-driven opening contacts (for I/R 16 kW and UI 10 kW, only from Order No. [MLFB]: 6SN114□-1□□01-0□□□)  
Terminals 111–113 NO contact not positively-driven  
For I/R 16 kW (from version E) and UI 10 kW (from version F) the following apply:  
Terminals 111–213, positively-driven opening contacts (series circuit of NC contact, main contactor and NC contact, pre-charging contactor)  
Terminals 111–113, positively-driven NO contacts
- Max. current load of terminal 9 with respect to terminal 19: 0.5 A.
- Only for UI 28 kW
- For UL certification, only use copper cables dimensioned for an operating temperature  $\geq 60^\circ\text{C}$
- Max. permissible connected power:  $P_{\text{max}} \leq 43 \text{ kW}$ ; max. permissible current load:  $I_{\text{max}} \leq 72 \text{ A}$
- When the AS1/AS2 contacts are connected in series a contact resistance of approx. 0.20 Ohm must be taken into consideration over the lifetime of the contacts. For a 24 V switching voltage, from experience, a series circuit of up to five contacts can be used without any problems due to the non-linear contact characteristics.
- In accordance with EN 60204-1 (machine safety), control transformers must be used for AC control voltages.

Table 6-1 Interface description for NE modules, continued

Term. No.	Designation	Function	Type 1)	Typ. voltage/limit values for $V_n$ 400 V	Max. cross-section <sup>10)</sup>	Terminals provided on <sup>3)</sup>
7 45 44 10 15 <sup>2)</sup> R <sup>6)</sup>	X141 X141 X141 X141 X141 X141	P24 P15 N15 N24 M RESET	O O O O O I	+20,4...28,8 V/50 mA +15 V/10 mA -15 V/10 mA -20,4...28,8 V/50 mA 0 V KL15/R <sub>E</sub> = 10 kΩ	1.5 mm <sup>2</sup> 1.5 mm <sup>2</sup> 1.5 mm <sup>2</sup> 1.5 mm <sup>2</sup> 1.5 mm <sup>2</sup> 1.5 mm <sup>2</sup>	I/R, UI, monitoring module
9 <sup>2)8)</sup> 112 <sup>2)</sup>	X161 X161	Enable voltage Setting-up operation/ normal operation	O I	+24 V +21 V...30 V/R <sub>E</sub> = 1.5 kΩ	1.5 mm <sup>2</sup> 1.5 mm <sup>2</sup>	I/R, UI, monitoring module
48 <sup>2)</sup> 111 <sup>7)</sup> 213 <sup>7)</sup> 113 <sup>7)</sup>	X161 X161 X161 X161	Contactor control Signaling contacts, line contactor	I I NC NO	+13 V...30 V/R <sub>E</sub> = 1.5 kΩ +30 V/1 A (111-113) 1-ph. 250 V AC/50 V DC/ 2 A max 17 V DC/3 mA min	1.5 mm <sup>2</sup> 1.5 mm <sup>2</sup> 1.5 mm <sup>2</sup> 1.5 mm <sup>2</sup> max. cable length, 30 m	I/R, UI
NS1 NS2	X171 X171	Coil contact for line supply, pre- charging contactor	O I	+24 V	1.5 mm <sup>2</sup> 1.5 mm <sup>2</sup>	I/R, UI
AS1 <sup>12)</sup> AS2 <sup>12)</sup>	X172 X172	Signaling contact Start inhibit (T.112)	I NC	max. 250 V/1 A AC <sup>13)</sup> / 30 V/2 A DC	1.5 mm <sup>2</sup> 1.5 mm <sup>2</sup>	I/R

- 1) I = input; O = output; NC = NC contact; NO = NO contact; (for signal, NO = high; NC = low)  
P = only for PELV voltage; S = only for SELV voltage
- 2) Term. 19 is the reference ground (connected through 10 kΩ to the general reference ground X131/T.15 inside the module)  
Terminal 15 must not be connected to PE, to terminal 19 or to external voltage sources.  
Terminal 19 can be connected with X131.  
The terminal may be used only for enabling the associated drive group.
- 3) I/R = infeed/regenerative feedback module; UI = unregulated infeed; MM = monitoring module;  
PR = pulsed resistor module
- 4) The first data applies with pin-type cable lug. The second data is used for finely-stranded cable without end sleeve.
- 5) The grounding clip is used to ground the DC link M600 busbar through 100 kΩ (must be closed and must not be closed if RCCBs are used, see also Chapter 8.1;  
the grounding clip must be opened if the system is subject to a high-voltage test).
- 6) RESET = resets the fault memory, edge-triggered for the complete drive group (terminal "R" → Terminal 15 = RESET)
- 7) Terminals 111-213, positively-driven opening contacts (for I/R 16 kW and UI 10 kW, only from Order No. [MLFB]: 6SN114□-1□□01-0□□□)  
Terminals 111-113 NO contact not positively-driven  
For I/R 16 kW (from version E) and UI 10 kW (from version F) the following apply:  
Terminals 111-213, positively-driven opening contacts (series circuit of NC contact, main contactor and NC contact, pre-charging contactor)  
Terminals 111-113, positively-driven NO contacts
- 8) Max. current load of terminal 9 with respect to terminal 19: 0.5 A.
- 9) Only for UI 28 kW
- 10) For UL certification, only use copper cables dimensioned for an operating temperature  $\geq 60^\circ\text{C}$
- 11) Max. permissible connected power:  $P_{\text{max}} \leq 43 \text{ kW}$ ; max. permissible current load:  $I_{\text{max}} \leq 72 \text{ A}$
- 12) When the AS1/AS2 contacts are connected in series a contact resistance of approx. 0.20 Ohm must be taken into consideration over the lifetime of the contacts. For a 24 V switching voltage, from experience, a series circuit of up to five contacts can be used without any problems due to the non-linear contact characteristics.
- 13) In accordance with EN 60204-1 (machine safety), control transformers must be used for AC control voltages.



### Warning

In order to avoid damage to the infeed circuit of the NE modules, when controlling/energizing terminal 50 at X221 (PR module, DC link fast discharge) it should be ensured that terminal 48 of the NE module is de-energized (the module is then electrically isolated from the line supply). The feedback signal contacts from the main contactor of the NE module (X161 term. 111, term. 113, term. 213) must be evaluated.

## 6.2 Interface overview

## 6.2.2 5 kW UI module interface overview

Table 6-2 Interface overview, 5 kW UI modules

Term. No.	Designation	Function	Type <sup>1)</sup>	Typ. voltage/limit values	Max. cross-section <sup>6)</sup>		
U1 V1 W1	X1	Line supply connection	I	3-ph. 400 V AC	4 mm <sup>2</sup> finely-stranded without conductor end sleeves 6 mm <sup>2</sup> with pin-type cable lug		
	– X131 X351	Protective conductor Electronics M Equipment bus Grounding bar <sup>3)</sup>	I I I/O I/O	0 V 0 V Various –300 V	M5 thread M4 thread 34-core ribbon cable Busbar		
P600 M600		DC link	I/O	+300 V –300 V	Conductor bar		
M500 P500 1U1 2U1 1V1 2V1 1W1 2W1	X181 X181 X181 X181 X181 X181 X181 X181	DC link power supply DC link power supply Output L1 Input L1 Output L2 Input L2 Output L3 Input L3	I I O I O I O I	–300 V +300 V 3-ph. 400 V AC 3-ph. 400 V AC 3-ph. 400 V AC 3-ph. 400 V AC 3-ph. 400 V AC 3-ph. 400 V AC	1.5 mm <sup>2</sup> 1.5 mm <sup>2</sup> 1.5 mm <sup>2</sup> 1.5 mm <sup>2</sup> 1.5 mm <sup>2</sup> 1.5 mm <sup>2</sup> 1.5 mm <sup>2</sup> 1.5 mm <sup>2</sup>		
5.3 5.2 5.1 nc	X121A X121A X121A X121A	} Relay contact Group signal I <sup>2</sup> /motor temperature	NC NO I	1-ph. 50 V DC/0.5 A/12 VA max 1-ph. 5 V DC/3 mA min	1.5 mm <sup>2</sup> 1.5 mm <sup>2</sup> 1.5 mm <sup>2</sup> 1.5 mm <sup>2</sup>		
74 73.2 73.1 72	X121B X121B X121B X121B		} Relay signal Ready/ fault	NC I I NO	1-ph.250 V AC/50 V DC/2 A max <sup>7)</sup> 5 V DC/3 mA min	1.5 mm <sup>2</sup> 1.5 mm <sup>2</sup> 1.5 mm <sup>2</sup> 1.5 mm <sup>2</sup>	
63 <sup>2)</sup> 9 <sup>2)4)</sup> 9 <sup>2)4)</sup> 64 <sup>2)</sup> R <sup>5)</sup> 19	X141AX 141A X141A X141A X141A X141A			Pulse enable FR+ FR+ Drive enable RESET FR–, reference ground enable voltage	I O O I I O	+13 V...30 V/R <sub>E</sub> = 1.5 kΩ +24 V +24 V +13 V...30 V/R <sub>E</sub> = 1.5 kΩ terminal 19/R <sub>E</sub> = 10 kΩ	1.5 mm <sup>2</sup> 1.5 mm <sup>2</sup> 1.5 mm <sup>2</sup> 1.5 mm <sup>2</sup> 1.5 mm <sup>2</sup> 1.5 mm <sup>2</sup>

1) I = input; O = output; NC = NC contact; NO = NO contact

2) Term. 19 is the reference ground (connected through 10 kΩ to the general reference ground X131 inside the module)  
Terminal 15 must not be connected to PE, to terminal 19 or to external voltage sources  
Terminal 19 can be connected to X131.

The terminal may be used exclusively for enabling the associated drive group.

3) The grounding clip is used to ground the DC link M busbar through 100 kΩ (must be closed; the grounding clip must be opened if the system is subject to a high-voltage test).

4) max. current load of terminal 9 – terminal 19 ≤ 1 A

Notice: For the 5 kW, there are no terminals 7, 45, 44 and 10.

5) RESET = resets the fault memory, edge-triggered for the complete drive group  
(terminal "R" → Term. 19 = RESET)

6) For UL certification: only use copper cables dimensioned for an operating temperature ≥ 60 °C.

7) In accordance with EN 60204–1 (machine safety), control transformers must be used for AC control voltages.

Table 6-2 Interface overview, 5 kW UI modules, continued

Term. No.	Designation	Function	Type <sup>1)</sup>	Typ. voltage/limit values	Max. cross-section <sup>6)</sup>
111 213	X161 X161	} Signaling contact Line contactor	I NC	1-ph. 250 V AC/50 V DC/2 A <sup>7)</sup> 17 V DC/3 mA min	1.5 mm <sup>2</sup> 1.5 mm <sup>2</sup> max. cable length, 30 m
g <sup>2)4)</sup> 112 48 NS1 NS2 15	X141B X141B X141B X141B X141B X141B	FR+ Setup/normal operation Contactor control } Coil contact for line supply, pre-charging M contactor	O I I O I O	+24 V +13 V...30 V/R <sub>E</sub> = 1.5 kΩ +13 V...30 V/R <sub>E</sub> = 1.5 kΩ +24 V 0/+24 V 0 V	1.5 mm <sup>2</sup> 1.5 mm <sup>2</sup> 1.5 mm <sup>2</sup> 1.5 mm <sup>2</sup> 1.5 mm <sup>2</sup> 1.5 mm <sup>2</sup>

- 1) I = input; O = output; NC = NC contact; NO = NO contact
- 2) Term. 19 is the reference ground (connected through 10 kΩ to the general reference ground X131 inside the module)  
Terminal 15 must not be connected to PE, to terminal 19 or to external voltage sources  
Terminal 19 can be connected to X131.  
The terminal may be used exclusively for enabling the associated drive group.
- 3) The grounding clip is used to ground the DC link M busbar through 100 kΩ (must be closed; the grounding clip must be opened if the system is subject to a high-voltage test).
- 4) max. current load of terminal 9 – terminal 19  $\leq 1$  A  
Notice: For the 5 kW, there are no terminals 7, 45, 44 and 10.
- 5) RESET = resets the fault memory, edge-triggered for the complete drive group  
(terminal "R" → Term. 19 = RESET)
- 6) For UL certification: only use copper cables dimensioned for an operating temperature  $\geq 60^\circ\text{C}$ .
- 7) In accordance with EN 60204-1 (machine safety), control transformers must be used for AC control voltages.

---

### Notice

There are no 7, 45, 44 and 10 terminals for the 5 kW UI module.

---



## 6.2 Interface overview

## 6.2.3 Cable cross-sections that can be connected

The cable cross-sections that can be connected are listed in Table 6-3:

Table 6-3 Cable cross-sections that can be connected at the infeed module (line supply connection)

MLFB		Connection cross-section [mm <sup>2</sup> ]														1)	2)
		1,5	2,5	4	6	10	16	25	35	50	70	95	120	150		[Nm]	
6SN1143-1BB00-0FA□	120 kW														X	M6	25...30
6SN1143-1BB00-0EA□	80 kW														X	M6	15...20
6SN1145-1BA01-0DA□	55 kW														X	M6	15...20
6SN1145-1BB00-0DA□	55 kW														X	M6	15...20
6SN1145-1BA02-0CA□	36 kW														X	M6	6...8
6SN1145-1BA01-0BA□	16 kW						X									M5	1,5...1,8
6SN114□-1A□01-0BA□	28 kW														X	M6	6...8
6SN1145-1AA01-0AA□	10 kW						X									M5	1,5...1,8
6SN1146-1AB00-0BA□	5 kW	X	X	X	X											M5	0,7...0,8
Key		Terminal area for flexible cable with end sleeves (with or without plastic collars)															
		Terminal area for flexible cables with terminal pin															
	X	IP20 is guaranteed when correctly used, e.g. insulated pin-type cable lugs															

- 1) Size of the screw for the protective conductor connection
- 2) Tightening torque of the terminals or connectors

6.2.4 Three-conductor connection (standard circuit)

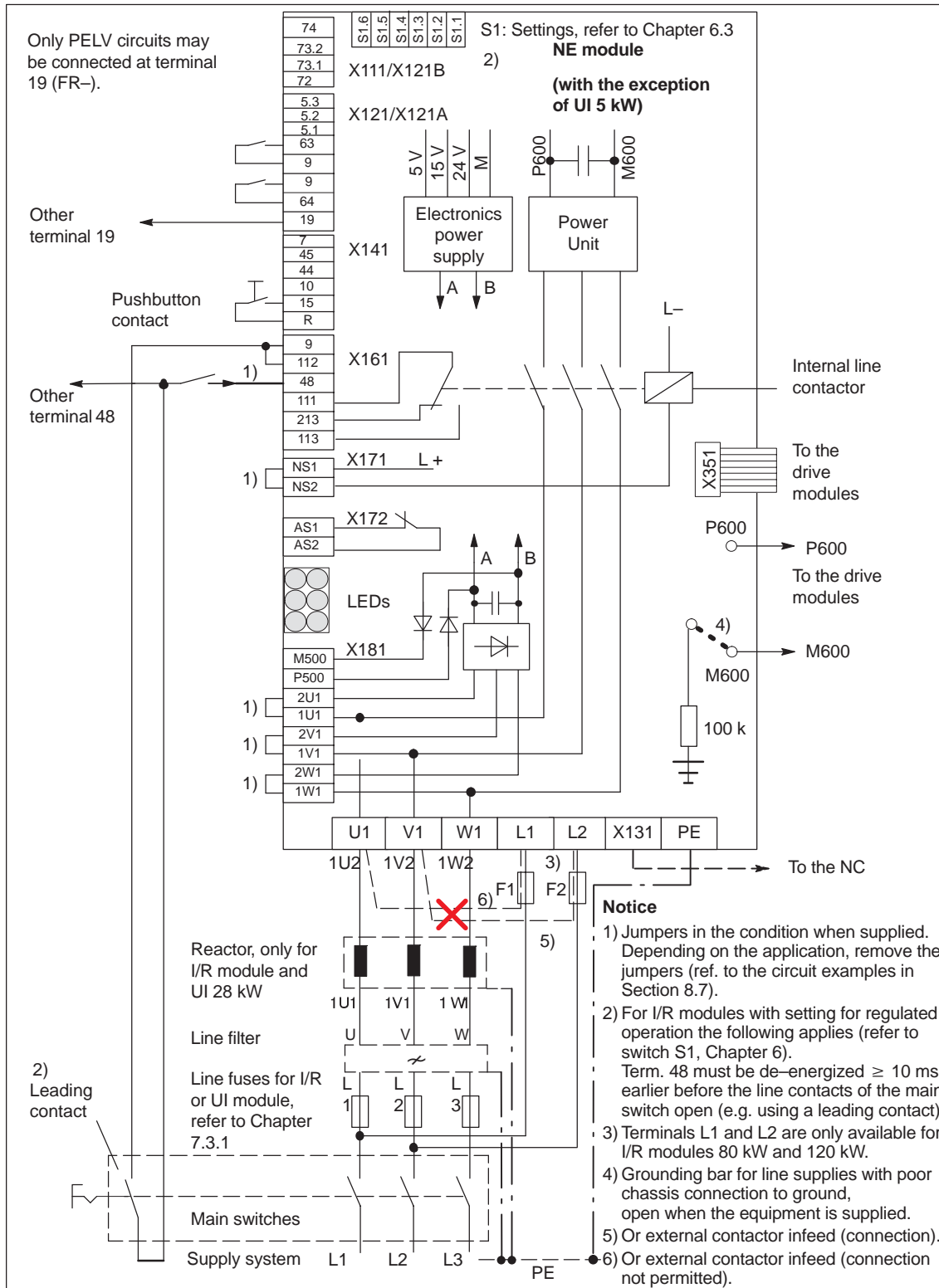

Fig. 6-6 Three-conductor connection (standard circuit)

### 6.2.5 Description of the interfaces and functions

<b>Switch S1</b>	Switch S1 to set various functions is provided on the upper side of the NE and monitoring module or on the front side/panel for the UI module 5 kW; refer to Chapter 6.3.
<b>Terminal 19</b>	<p><b>EN-</b></p> <p>Reference potential for the enable voltage terminal 9, non-floating (with electrical isolation) (connected to the general reference ground terminal 15 through 10 k<math>\Omega</math>). Terminal 19 is not permitted to be connected to terminal 15. (Connect to the PE bus or X131.)</p> <p>When controlling the enable signals using electronic outputs that switch to high (PLC), terminal 19 must be connected to the 0 V reference potential (ground) of the external power supply.</p> <p>The circuits/power source must satisfy the requirements for PELV (Protection Extra-Low Voltage) functional extra-low voltage with safe separation in accordance with EN 60204-1; 6.4.</p>
<b>Terminal 9</b>	<p><b>EN+</b></p> <p>Only use the +24 V enable voltage for the internal enable signals of the NE and drive modules.</p> <p>Maximum power supply load: 500 mA (corresponds to 8 EP; 1 optocoupler input requires 12 mA, for UI 5 kW <math>\rightarrow</math> 1 A)</p>
<b>Terminal 48</b>	<p><b>Start</b></p> <p>This terminal has the highest priority. A defined power-on and power-off sequence of the NE module is initiated using terminal 48.</p> <p>If terminal 48 is enabled (energized), then internally, the pre-charging sequence is initiated.</p> <p>(interrogation <math>V_{DC \text{ link}} \geq 300 \text{ V}</math> and <math>V_{DC \text{ link}} \geq \sqrt{2} \cdot U_{\text{line supply}} - 50 \text{ V}</math>).</p> <p>After the DC link has been charged, then, simultaneously</p> <ul style="list-style-type: none"> <li>• after 500 ms <math>\rightarrow</math> the pre-charging contactor is opened and the main contactor is closed.</li> <li>• after 1 second <math>\rightarrow</math> the internal enable signals are then issued.</li> </ul> <p>If terminal 48 is de-energized, then initially, after approx. 1 ms, the internal pulse enable signals are inhibited and then the DC link is electrically isolated from the line supply delayed by the drop-out time of the internal line contactor.</p> <p>If terminal 48 is opened (enabled) during the load operation, the load operation is first completed. The inhibit functionality for terminal 48 does not take effect until the load operation is complete, provided terminals NS1–NS2 are jumpered.</p>
<b>Terminals NS1, NS2</b>	<p><b>Coil circuit of the internal line and pre-charging contactor</b></p> <p>If the line contactor is opened (de-energized) by interrupting the coil circuit using electrically isolated (floating) contacts, then the DC link is safely and electrically disconnected from the line supply (signal contact, terminals 111–213 must be interrogated).</p> <p>The terminals have a safety-relevant function. The shutdown using terminals NS1–NS2 must be realized at the same time as or delayed with respect to terminal 48 start (refer to Section 8.7 Circuit examples = 2 and = 4).</p> <p>Max. cable length 50 m (2-conductor cable) for 1.5 mm<sup>2</sup> cross-section</p>
<b>Terminal 63</b>	<p><b>Pulse enable</b></p> <p>For the pulse enable and inhibit functionality, this terminal has the highest priority. The enable and inhibit functions are effective after approx. 1 ms simultaneously for all of the modules including the NE module. When the signal is withdrawn, the drives "coast down" unbraked.</p>

Standby operation of the infeed:

If an infeed module is to be kept in the ready state for a longer period of time (DC link charged), then in order to avoid unnecessary switching losses and reactor losses, a pulse inhibit should be enabled! The DC link voltage then remains at the non-regulated value and is again ready in the regulated mode immediately after the pulses have been enabled.

## Terminal 64

### Drive Enable

The drive modules are enabled using terminal 64. The modules are simultaneously enabled or inhibited after approx. 1 ms.

If terminal 64 is inhibited, then  $n_{\text{set}}=0$  is set for all drives and the axes brake as follows:

- For 611D/611 universal/ANA/HLA drives, the pulses are cancelled after a selectable speed has been undershot or after a selectable timer stage has expired. The axes brake along the selected limits (MD 1230, 1235, 1238).  
For spindles, a ramp can only be achieved using regenerative limiting (MD 1237).

## 6.2 Interface overview

**Terminals L1, L2****External switching voltage for the coil circuit of the line contactor**

Is used to supply the coil circuit of the internal line contactor only at the 80 kW and 120 kW I/R modules (do not connect between the I/R module and reactor).

Fuse:  $I_r \geq 4$  A, version gL

2-ph. 360 to 457 V AC/45 to 53 Hz; 400 to 510 V/57 to 65 Hz

Table 6-4 Technical data of the internal line and pre-charging contactor

I/R module	Type	Pull-in power [VA]		Holding power [VA]	
		50 Hz	60 Hz	50 Hz	60 Hz
6SN114□-1BB0□-0EA1	3TK48	330	378	36	44.2
6SN114□-1BB0□-0FA1	3TK50	550	627	32	39

Matching transformer for the coil connections L1, L2 at the line supply voltage 230 V and 380 V; for two 5TK5022-0AR0 contactors.

Table 6-5 Matching transformer SIDAC 1-phase autotransformer

	For 50 Hz line supplies	For 60 Hz line supplies
Type	4AM4096-0EM50-0AA0	4AM4696-0EM70-0FA0
Throughput rating [VA]	80	80
Input voltage [V]	380/230	380/230
Output voltage [V]	415 (min. 360/max. 458)	460/415
Output current [A]	0.193	0.19...0.17
Insulating material class	T40/B	T40/B
Applicable standard	EN 61558-13	VDE 0532
Frequency [Hz]	50/60	50/60
Vector group	IA0	li0
Degree of protection	IP00	IP00
Dimension sketch	PD10 T8/2	LV 10
for voltage fluctuations	+10% -13.2 %	+10% -13.2 %

**Note**

If, for the 80/104 kW or 120/156 kW I/R module, the line supply voltage at terminals L1, L2 fails or fuses F1, F2 trip, then only the pulses in the I/R module are cancelled and the internal line contactor drops-out.

This is displayed using the "line fault" LED, the ready relay and also the contactor signaling contacts. In this case, in order to re-close the internal line contactor, terminal 48 must be inhibited (de-energized) and re-energized after  $\geq$  one second or the unit must be powered-down/power-up.

**Terminal R****Reset**

The fault signal is reset using a pushbutton (pulse edge) between terminal R and terminal 15.

For the SIMODRIVE 611 universal HRS control unit, the reset is effective if, in addition, terminal 65 "controller enable" is also inhibited.

**Terminal 112****Set-up operation**

Terminal 112 is jumpered by default with terminal 9 (+24 V enable voltage).

Open: The step-up converter voltage control is set to start inhibit, monitoring disabled

Terminal 112 can only be used for SIMODRIVE 611 analog and not for SIMODRIVE 611 digital/universal.

**Terminals AS1, AS2****Signaling contact, start inhibit DC link controller**

Terminals AS1 – AS2 closed means that "start inhibit is effective" (i.e. terminal 112 = open, setup mode)

(not available for UI modules 5 kW, 10 kW, 28 kW)

Terminal 112 can only be used for SIMODRIVE 611 analog and not for SIMODRIVE 611 digital/universal.

**Terminal X131****Reference potential, electronics**

If analog setpoints are routed from an external controller to the drive group, then wire an equipotential bonding conductor via terminal X131. This cable must be routed in parallel to the speed setpoint cable.

Cross-section = 10 mm<sup>2</sup>!

**Terminals 7, 45, 44, 10, 15 (X141)****Electronics power supply**

- Terminal 7: P24 +20.4 to 28.8 V/50 mA
- Terminal 45: P15 +15 V/10 mA
- Terminal 44: N15 –15 V/10 mA
- Terminal 10: N24 –20.4 to 28.8 V/50 mA
- Terminal 15: M 0 V (only for circuits of terminals 7, 45, 44 and terminal 10; max. load, 120 mA)
  - Terminal 15 may not be connected to PE (ground loop)
  - Terminal 15 may not be connected to terminal 19 (otherwise there will be a short-circuit through the reactor; terminal 15 is internally connected to X131).

**Terminals 2U1, 2V1, 2W1**

Connecting terminals to separately supply the internal electronics power supply, e.g. through fused terminals (refer to the circuit example in Section 8.3.1).

In this case, jumpers 1U1–2U1, 1V1–2V1, 1W1–2W1 must be removed.

**Notice**

Observe additional information and instructions under Section 8.3 Monitoring module, and Section 8.15 Six-conductor connection!

## 6.2 Interface overview

**Terminal P500,  
M500**

Connect P500 and M500 for the internal coupling of the power supply to the DC link, e.g. for power failure concepts.

**Notice**

With this operating mode, terminals 2U1, 2V1, 2W1 of the power supply must be supplied with the line supply voltage between the I/R module and line reactor. The jumpers at connector X181 must under all circumstances be kept!

For a six-conductor connection (refer to Section 8.15), ensure a connection X181 (P500/M500) to the the DC link P600/M600 as specified in Section 8.15.2!

**Terminals 111, 113,  
213****Signaling contacts, internal line contactor**

111–113	NO contact
111–213	NC contact

**Terminals 72, 73.1,  
73.2, 74 (X111)****Ready relay**

Terminals 72 – 73.1: NO contact – closed for "Ready"  
Terminals 73.2 – 74: NC contact – open for "Ready"

In addition to the interface signals provided, the terminal signal 72/73 also includes the line supply infeed monitoring as well as signals from the watchdog and the reset controller of the closed-loop control. This signal is available to the control unit independently of the processor.

The function of terminals 72/73 is not a safety function in the sense of the Machinery Directive 98/37/EU.

For the switch position S1.2 = ON "Fault signal" the relay pulls-in if the following conditions are fulfilled:

- Internal main contactor CLOSED (terminals NS1 – NS2 connected, terminal 48 enabled).
- No faults may be present (on any of the SIMODRIVE drives in the group).
- The NCU/CCU must have booted (SINUMERIK 840D, 810D).

For the switch position S1.2 = OFF "Ready" the relay is activated if the following conditions are fulfilled:

- Terminal 48 is enabled.
- Terminals 63, 64 = on.
- VSA with High Standard/High Performance or resolver for the ready setting, must be enabled (terminal 663, 65)

If there is a fault, the relay drops-out.

With the exception of the line monitoring function, all of the internal monitoring functions on all of the drive modules are effective at the relevant equipment bus and also the ready signal. For line supply faults, only the I/R module pulses are inhibited.

**Notice**

The ready signal must be evaluated in the external NC control in order to derive enable signals, inhibit signals, fault responses, etc.

**Terminals 5.1, 5.2,  
5.3 (X121)****I<sup>2</sup>t pre-warning and motor temperature monitoring**

Terminals 5.1 – 5.2: NO contact    open for "no fault"

Terminals 5.1 – 5.3: NC contact    closed for "no fault"

**Notice**No I<sup>2</sup>t monitoring of the infeed!

You must ensure sufficient power of the infeed module by setting this parameter accordingly in the configuration.

Terminals 5.□ must be externally evaluated for the machine responses, for example, in the PLC. When the motor temperature monitoring responds, the user/machine manufacturer must define what the response should/must be

- Reduce the load on the machine
- Reduce the power
- Stop
- Shutdown

If the terminal is not evaluated, and the response that makes sense for this particular case is initiated in the machine control system, then this can destroy the system, converter or motor!

The relay is activated if:

- At NE module
  - Heatsink-temperature monitoring trips
- At 611D
  - Motor-temperature monitoring trips
  - Heatsink-temperature monitoring trips
  - I<sup>2</sup>t axis limiting responds
- At 611 universal HRS
  - Motor-temperature monitoring trips
  - Heatsink-temperature monitoring trips
  - I<sup>2</sup>t axis limiting responds

Input current, enable circuits:

Terminals 48, 63, 64, and 65: Input current, optocoupler approx. 12 mA at +24 V

Terminal 663: Input current, optocoupler and start inhibit relay approx. 30 mA at +24 V

When selecting the switching devices and the auxiliary contact on the main switch, the contact reliability when switching low currents must be carefully taken into consideration.

Switching capacity of the signaling contacts:

The max. switching power of the signaling contacts is specified in the interface overviews of the modules in Chapters 4 and 6, and must be absolutely complied with!



**Note**

All of the connected actuators, contactor coils, solenoid valves, holding brakes, etc. must be provided with overvoltage limiting elements, diodes, varistors, etc.

This is also true for switchgear/inductances controlled by a PLC output.

**Display elements (LEDs)**

The NE and monitoring modules have the following display elements (LEDs):

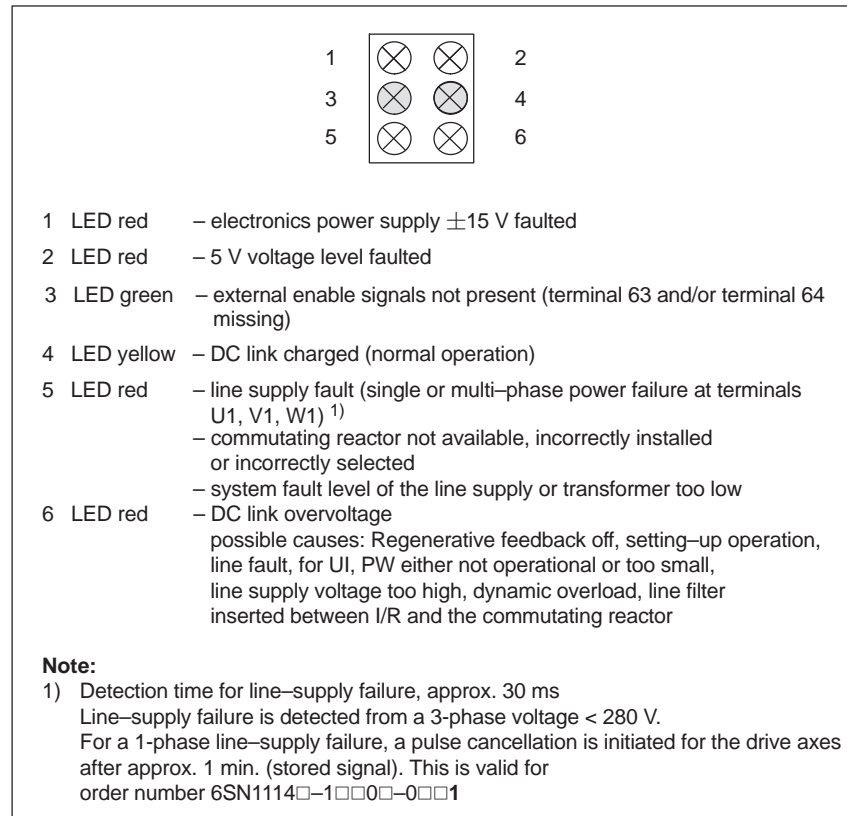

Fig. 6-7 Display element, NE and monitoring module

**Effects of the display states:**

- |                    |                                                                                                                                                                     |
|--------------------|---------------------------------------------------------------------------------------------------------------------------------------------------------------------|
| 1 LED red bright:  | Pulses are cancelled for the complete drive group                                                                                                                   |
| 2 LED red bright:  | Pulses are cancelled for the complete drive group                                                                                                                   |
| 4 LED yellow dark: | Pulses are cancelled for the complete drive group                                                                                                                   |
| 5 LED red bright:  | Pulses are only cancelled for the I/R module (regenerative feedback into the line supply no longer possible. Axes initially continue to run. Ready relay drops out) |
| 6 LED red bright:  | Pulses are cancelled for the complete drive group                                                                                                                   |

**Display, line fault**

If a line fault is displayed or if the yellow LED does not light, the overvoltage limiter module must be checked.

Procedure:

1. Switch the unit into a no-voltage condition
2. Withdraw the overvoltage limiter module and insert connector X181 on the NE module.

Does the NE module function correctly?

Yes —> The overvoltage limiter module is defective and must be replaced.

No —> Check the line supply and possibly the NE module/group.

---

**Note**

Operation can continue, but **without overvoltage protection** when the overvoltage limiter module is withdrawn and connector X181 has been removed from the NE module!

Operation without overvoltage limiter module is not in conformance with UL!

---

3. Insert a new overvoltage limiter module up to its endstop and reinsert connector X181 on the overvoltage limiter module.

## 6.3 Function overview and settings

### General information

A switch S1 is provided on the upper side of the NE and monitoring module that is used to set the following functions (for UI 5 kW on the front side):

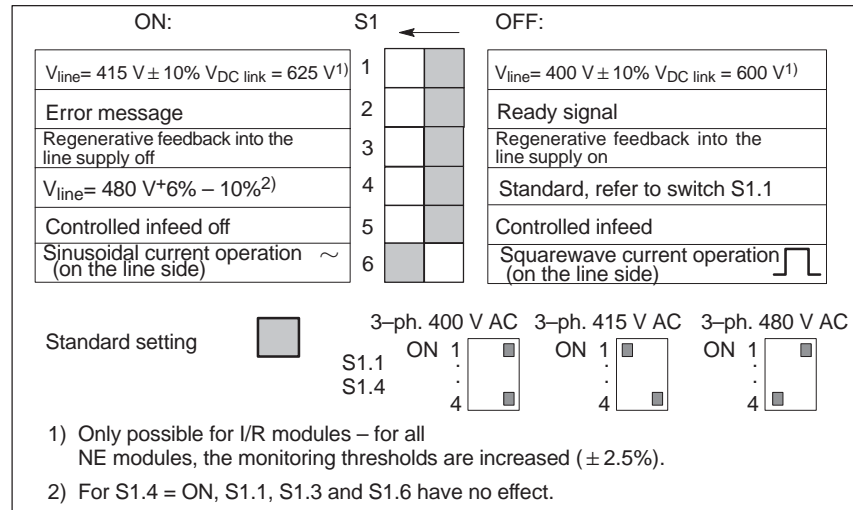

Fig. 6-8 DIL switch S1

### Note

For a configuration 480 V S1.4= ON, only controlled regenerative feedback is realized, independent of the position of S1.5.

### Notice

For I/R modules, sinusoidal current mode is the initial setting.

For operation with filters that are not listed in Table 6-6, the mode must be changed to squarewave current mode in order to protect the filter from thermal overload.

Before powering up or down using the main switch or a line contactor, terminal 63 (pulse enable) and/or terminal 48 (start terminal, contactor control) must be de-energized!

### Switch S1.1

OFF: I/R module     $U_{line} = 400 \text{ V} \pm 10\%$ ;  $V_{DC \text{ link}} = 600 \text{ V} \pm 2.5\%$   
 UI module     $V_{line} = 400 \text{ V} \pm 10\%$ ;  $V_{DC \text{ link}} = V_{line} \cdot 1.35$   
 Monitoring thresholds: (I/R, UI, monitoring modules)  
 PR on = 644 V;    PR off = 618 V  $\pm 2.5\%$   
 $V_{DC \text{ link}} \geq 695 \text{ V} \pm 2.5\%$

ON: I/R module     $V_{line} = 415 \text{ V} \pm 10\%$ ;  $V_{DC \text{ link}} = 625 \text{ V} \pm 2.5\%$   
 UI module     $V_{line} = 415 \text{ V} (440 \text{ V}) \pm 10\%$ ;  $V_{DC \text{ link}} = V_{line} \cdot 1.35$   
 Monitoring thresholds: (I/R, UI, monitoring modules)  
 PR on = 670 V  $\pm 2.5\%$ ;    PR off = 640 V  $\pm 2.5\%$   
 $V_{DC \text{ link}} \geq 710 \text{ V} \pm 2.5\%$

PR = Pulsed resistor

**Switch S1.2**

OFF: Ready signal (X111 ready relay)

For S1.2 = OFF, the relay pulls-in if the following conditions are fulfilled:

- Internal main contactor CLOSED (terminals NS1 – NS2 connected, terminal 48 enabled)
- Terminals 63, 64 = ON
- No fault present (also not at the FD 611 A Standard, 611 U, resolver and 611 D drives and HLA modules).
- FD with High Standard or resolver for the setting "ready" is enabled (terminals 663, 65)
- For 840D/810D, the NCU must have run-up

ON: Fault signal (X111 ready relay)

For S1.2 = ON, the relay picks up if the following conditions are fulfilled:

- Internal main contactor CLOSED (terminals NS1 – NS2 connected, terminal 48 enabled)
- No fault present (also not at the FD 611 A Standard, 611 U, resolver and 611 D drives and HLA modules).
- FD with High Standard or resolver for the setting "ready" is enabled (terminals 663, 65)
- For 840D and 810D the NCU must have run-up

**Switch S1.3**

OFF: Standard setting, regenerative feedback into the line supply active  
 I/R modules: 16 kW to 120 kW are capable of regenerative feedback.  
 UI module: 5 kW, 10 kW, 28 kW: The pulsed resistor in the module is effective and active.

ON: Regenerative feedback to the line supply is switched off  
 I/R modules: 16 kW to 120 kW: Regenerative feedback mode is disabled  
 UI module: 5 kW, 10 kW: The pulsed resistor in the module is not active

Valid for  
 UI 5 kW, Order No.: 6SN1146–1AB00–0BA1 and  
 UI 10 kW, Order No.: 6SN1145–1AA01–0AA1

Not valid for UI 28 kW. In this case, the external pulsed resistor must be disconnected.

**Switch S1.4**

OFF: Standard setting for all NE modules, refer to S 1.1

ON:  $V_{line} = 480 \text{ V} +6\% / -10\%$ ;  $V_{DC \text{ link}} = V_{line} \cdot 1.35$  in infeed mode  
 $V_{DC \text{ link}} = 700 \text{ to } 750 \text{ V} \pm 2.5\%$  in regenerative feedback mode  
 Monitoring thresholds: (I/R, UI, monitoring modules)  
 PR on =  $744 \text{ V} \pm 2.5\%$ ; PR off =  $718 \text{ V} \pm 2.5\%$   
 $V_{DC \text{ link}} \geq 795 \text{ V} \pm 2.5\%$   
 S1.4 exceeds the setting of S1.1

**Please note!** Unregulated operation in the infeed direction.

**Warning**

An incorrect switch setting ("OFF") for S1.4 when connected to  $U_{line} = 480 \text{ V}$  will overload the NE module and destroy it!

## 6.3 Function overview and settings

**Switch S1.5**

This function is only applicable in conjunction with I/R modules

Order No.: 6SN114□-1B□0□-0□A1

OFF: regulated infeed active (default setting)

ON: Unregulated operation in the infeed direction  $V_{DC \text{ link}} = V_{\text{line}} \cdot 1.35$

**Notice:**

For unregulated operation of the I/R units with  $V_{\text{line}} = 400 \text{ V}/415 \text{ V}$ , the power must be reduced (derated) as specified in Section 5.5.

**Switch S1.6**

OFF: Squarewave current operation (current with a squarewave shape is drawn from the line supply)

ON: This function is only applicable in conjunction with I/R modules with Order No.: 6SN114□-1B□0□-0□A1 sinusoidal current operation (sinusoidal current is taken from the line supply)

**Combinations of the components:**

Table 6-6 Combinations (regenerative feedback into the line supply)

I/R 16 kW	I/R 36 kW	I/R 55 kW	I/R 80 kW	I/R 120 kW
<b>For internal Cooling:</b>	<b>For internal Cooling:</b>	<b>For internal Cooling:</b>	<b>For internal Cooling:</b>	<b>For internal Cooling:</b>
6SN1145- 1BA01-0BA□	6SN1145- 1BA02-0CA□	6SN1145- 1BA01-0DA□	6SN1145- 1BB00-0EA□	6SN1145- 1BB00-0FA□
<b>For external Cooling:</b>	<b>For external cooling:</b>	<b>For external cooling:</b>	<b>For external Cooling:</b>	<b>For external cooling:</b>
6SN1146- 1BB01-0BA□	6SN1146- 1BB02-0CA□	6SN1146- 1BB00-0DA□	6SN1146- 1BB00-0EA□	6SN1146- 1BB00-0FA□
<b>HFD reactor 16 kW</b>	<b>HFD reactor 36 kW</b>	<b>HFD reactor 55 kW</b>	<b>HFD reactor 80 kW</b>	<b>HFD reactor 120 kW</b>
6SL3000- 0DE21-6AA□	6SL3000- 0DE23-6AA□	6SL3000- 0DE25-5AA□	6SL3000- 0DE28-0AA□	6SL3000- 0DE31-2AA□
<b>Wideband Line Filter 16 kW</b>	<b>Wideband Line Filter 36 kW</b>	<b>Wideband Line Filter 55 kW</b>	<b>Wideband Line Filter 80 kW</b>	<b>Wideband Line Filter 120 kW</b>
6SL3000- 0BE21-6AA□	6SL3000- 0BE23-6AA□	6SL3000- 0BE25-5AA□	6SL3000- 0BE28-0AA□	6SL3000- 0BE31-2AA□
<b>Basic Line Filter 16 kW</b>	<b>Basic Line Filter 36 kW</b>	<b>Basic Line Filter 55 kW</b>	-	-
6SL3000- 0BE21-6DA□	6SL3000- 0BE23-6DA□	6SL3000- 0BE25-5DA□	-	-

## 6.4 Technical data

### 6.4.1 General information

The configuring of the infeed modules requires the performance data from the Tables 6-9 and 6-10 and the following performance curves.

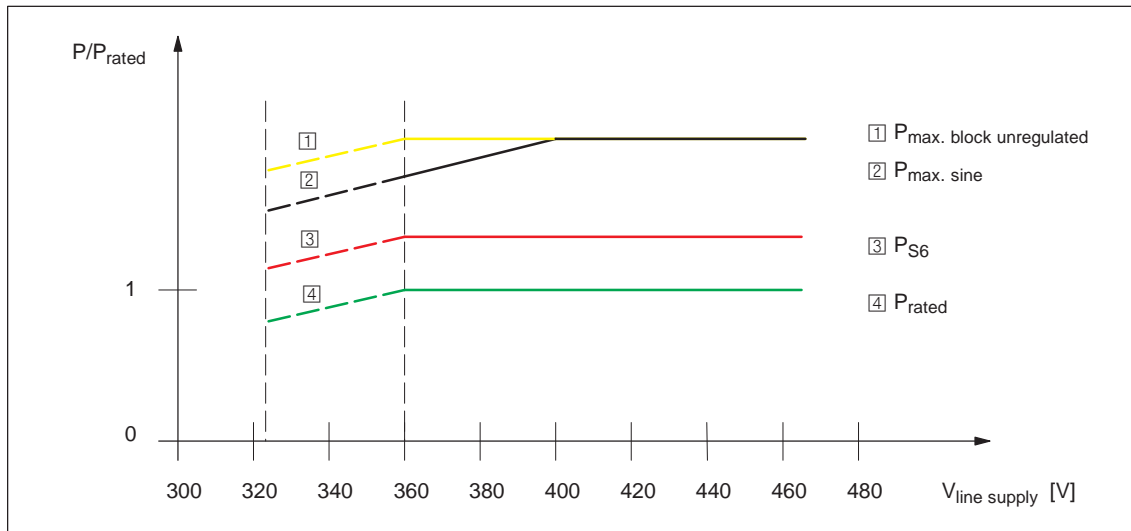

Fig. 6-9 Normalized power graph

#### Note

When connected to line supplies with voltage fluctuations below the rated voltage, the infeed should be oversized corresponding to the above diagram (Fig. 6-9), otherwise this can lead to failures or defects.

Table 6-7 Power factory at the rated power without filter

Module	Operation on the line side	Factor $\cos \varphi^{1)}$	Factor $\lambda$
I/R	Sinusoidal current operation	$\cos \varphi \approx 0.98$	$\lambda \approx 0.97$
I/R	Squarewave current operation	$\cos \varphi \approx 0.98$	$\lambda \approx 0.89$
UE	–	$\cos \varphi \approx 0.87$	$\lambda \approx 0.67$

$\cos \varphi$ : The power factor only contains the basic fundamental

$\lambda$ : The power factor contains the basic fundamental and harmonic components

1) Is valid for sinusoidal current operation at the rated voltage without filter

#### Note

With line filter, when the converter is operating at partial load, a capacitive phase shift occurs.

As line supplies in companies generally have an inductive phase shift, this capacitive component has a compensating effect in this line supply.

## 6.4 Technical data

**Supply voltage and frequency**

Switches S1.1 and S1.4 (see Chapter 6.3) are used to adapt the line infeed modules to the prevailing line supply conditions.

The converter system is designed for operation on grounded line supplies TN-S and TN-C (IEC 60364-1 VDE 0100-300). For other line supply types, a transformer with separate windings in vector group yn on the secondary side must be connected upstream (refer to Chapter 7 for the dimensioning).

Table 6-8 Supply voltage and frequency

NE-Module	S1.1, S1.4 = OFF Un = 3AC 400 V	S1.1 = ON Un = 3AC 415 V	S1.4 = ON Un = 3AC 480 V
Line voltage: U1, V1, W1	3AC 400 V ± 10%	3AC 415 V ± 10%	3AC 480 V + 6% -10%
With derating P <sub>rated</sub> and P <sub>max</sub> <sup>1)</sup>	3AC 380 V ± 15%		
DC link voltage	DC 600 V	DC 625 V	DC 580...710 V
Frequency	45...65 Hz		55...65 Hz

1) See Table 6-9, Technical data I/R modules

This means that the operational reliability is increased even when connected to weak line supplies!

Table 6-9 Technical specifications, I/R modules

Internal cooling External cooling Hose cooling	6SN11 45- 6SN11 46- 6SN11 45-	1BA0□-0BA□ 1BB0□-0BA□ -	1BA0□-0CA□ 1BB0□-0CA□ -	1BA0□-0DA□ 1BB0□-0DA□ 1BB0□-0DA□	1BB0□-0EA□ 1BB0□-0EA□ 1BB0□-0EA□	1BB0□-0FA□ 1BB0□-0FA□ 1BB0□-0FA□
Infeed/regenerative feedback	kW	16	36	55	80	120
Rated power (S1)	kW	21	47	71	104	156
S6 power	kW	35	70	91	131	175
Peak power (400 V)					2)	2)
Sinusoidal operation input currents (AC <sub>RMS</sub> )	Use for dimensioning the installation, not for calculating the power!					
Rated current (400 V)	A <sub>rms</sub>	27	60.5	92.5	134	202
Squarewave operation input currents (AC <sub>RMS</sub> )	Use for dimensioning the installation, not for calculating the power!					
Rated current (400 V)	A <sub>rms</sub>	30	67	102	149	223
	Use for dimensioning the installation, not for calculating the power! (calculated)					
Rated current (400 V) unregulated operation	A <sub>rms</sub>	33	74	114	165	248
Connection data						
Voltage (power)	V <sub>rms</sub>	refer to Chapter C.1.3, Table 3.5				
Voltage (electronics)	V	refer to Chapter C.1.3, Table 3.5				
Power supply	V <sub>rms</sub>	At the DC link with 600/625/680 V DC or supplied in parallel, AC and DC connection or DC connection only.				
Frequency	Hz	50 to 60 ±10%				
Connection cross-section	mm <sup>2</sup>	Max. 16	Max. 50	Max. 95	Max. 95	Max. 150
Output voltage	V	regulated: 600/625; unregulated: 490...680 (line supply-dependent)				
Module width	mm	100	200	300	300	300
Type of cooling						
Internal cooling (volumetric flow rate)	m <sup>3</sup> /h	Fan 56	Fan 112	Fan 112	Built-on fan 400 <sup>3)</sup>	Built-on fan <sup>1)</sup> 400 <sup>3)</sup>
External cooling <sup>1)</sup>		Fan	Fan	Mounting frame (Bestell-Nr. 6SN1162-0BA04-0EA□) with fan assembly and built-on fan (6SN1162-0BA02-0AA2		
Hose cooling		-	-	Kit for hose cooling with fan		
Losses						
Internal cooling	W	320	585	745	1280	1950
External cooling	W (int./ext.)	50/270	50/535	115/630	190/1090	290/1660
Hose cooling	W (int./ext.)	-	-	115/630	190/1090	290/1660
Efficiency η		0.97	0.97	0.97	0.97	0.97
Weight						
Internal cooling	kg	10.5	15.5	26	26	29
External cooling	kg	10.5	15.5	26	26	29
Hose cooling	kg	-	-	26	26	29

- 1) For a module width of 300 mm with external cooling, mounting frames are required that must be ordered separately. The fan assembly required to mount the built-on fan is included in the scope of supply of the mounting frame. The built-on fan must be ordered separately! Mounting frames are also available for smaller module widths. However, these are not required if openings are cut out in the rear cabinet panel for the module heatsinks as shown in this Configuration Manual.
- 2) External power supply for main contactor control required (see Chapter 6.2.5).
- 3) ) Must be separately ordered: Mounted fan, 6SN1162-0BA02-0AA2
- 4) See the diagram with pipe cooling in Chapter 2.7.1, Fig. 2-7



## 6.4 Technical data

Table 6-10 Technical data, UI modules

Heat dissipation	6SN11 45-	–	1AA01–0AA□ (INT./EXT.)	1AA00–0CA□ (INT.)
Heat dissipation	6SN11 46-	1AB00–0BA□ (INT./EXT.)	–	1AB00–0CA□ (EXT.)
Hose cooling	6SN11 45-	–	–	–
<u>Infeed/regenerative feedback</u>				
Rated power (S1)	kW	5	10	28
S6 power	kW	6.5	13	36
Peak power (400 V)	kW	10	25	50
Input currents (AC <sub>RMS</sub> )	Use for dimensioning the installation, not for calculating the power!			
Rated current (400 V)	12	24	68	
Built-in pulsed resistor				
Continuous power/ Peak power	kW	0,2/10	0,3/25	–
Energy consumption, max:	kWs	E = 13,5	E = 7,5	–
<u>Connection data</u>				
Voltage (power)	V	refer to Chapter C.1.3, Table 3.5		
Voltage (electronics)	V	refer to Chapter C.1.3, Table 3.5		
Power supply	V	At DC link with 600/625/680 V DC or parallel infeed, AC and DC connection		
Frequency	Hz	50 to 60 ±10%		
Connection cross-section, max.	mm <sup>2</sup>	6	16	50
Output voltage	V	0...490...680 depending on the line supply voltage		
Output frequency	Hz	0...1400 depending on the control unit		
Module width	mm	50	100	200
<u>Type of cooling</u>				
Internal cooling		Non-ventilated	Universal cooling	Internal separately-driven fan
External cooling		Non-ventilated	internal/external	Integrated third-party fan (volumetric flow, both 42 m <sup>3</sup> /hr)
Hose cooling		–	–	–
<u>Losses</u>				
Internal cooling	W	270	450	250
External cooling	W (int./ext.)	270/–	120/330	90/160
Hose cooling	W (int./ext.)	–	–	–
Efficiency $\eta$		0.98	0.98	0.98
<u>Weight</u>				
Internal cooling	kg	6.5	9.5	15.5
External cooling	kg	6.5	9.5	15.5
Hose cooling	kg	–	–	–

**Note**

Temperature derating, see Chapter 5.4.2.

Installation altitude derating, see Chapter 5.4.3.

## 6.4.2 Permissible duty cycles/derating

### Nominal load duty cycles for NE modules

For a derating, it must be analyzed as to the reason why this is required, and which component is involved. For instance, if derating is required as a result of the line voltage, then for uncontrolled infeed modules, the maximum motor speed must be correspondingly adapted.

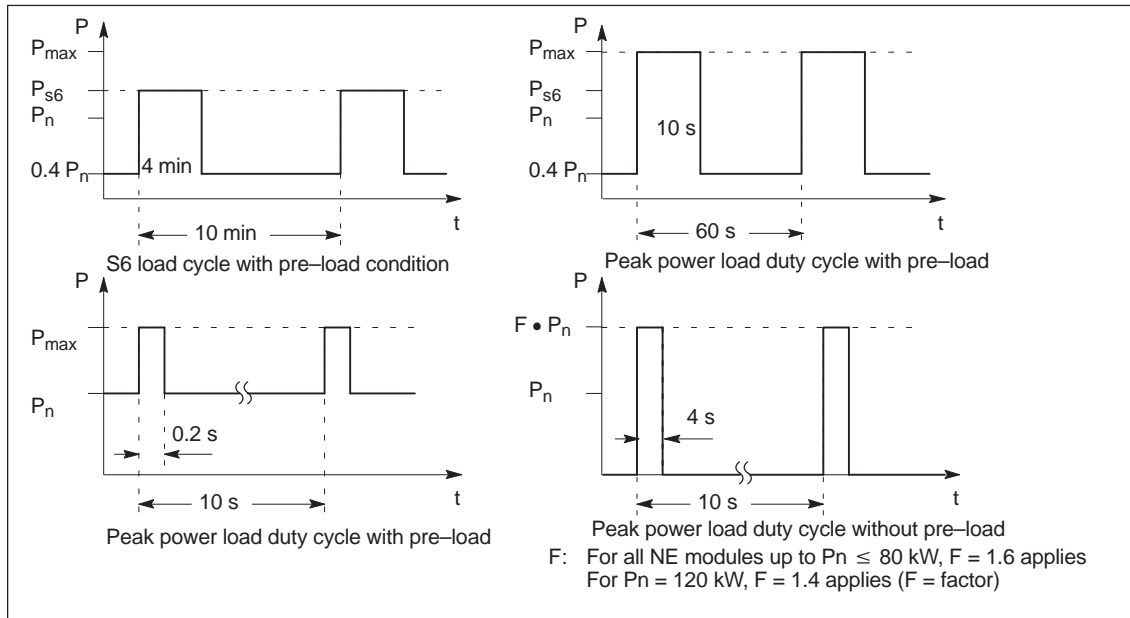

Fig. 6-10 Nominal load duty cycles for NE modules

### Calculation of maximum permissible line infeed load

The effective load must be determined over a load period/cycle and this must be set to the ratio for the rated power of the module. The resulting weighting factor B must not exceed the factors of the associated time interval T indicated in Table 6-11. Note that the maximum  $P_{max}$  must not be exceeded at any time and the derating factor, depending on the pulse frequency and/or installation altitude, must be taken into account!

As a rule of thumb, the following applies for block-type load duty cycles:

$$B = \sqrt{\frac{P_1^2 \cdot t_1 + P_2^2 \cdot t_2 + \dots + P_k^2 \cdot t_k}{T \cdot P_n^2}}$$

- T Total duration of the load duty cycle
- $P_n$  Rated power of the I/R module
- $P_1 \dots P_k$  Magnitude of the required power
- $t_1 \dots t_k$  Duration of the corresponding power
- B Evaluation factor for the load duty cycle according to Table 6-11

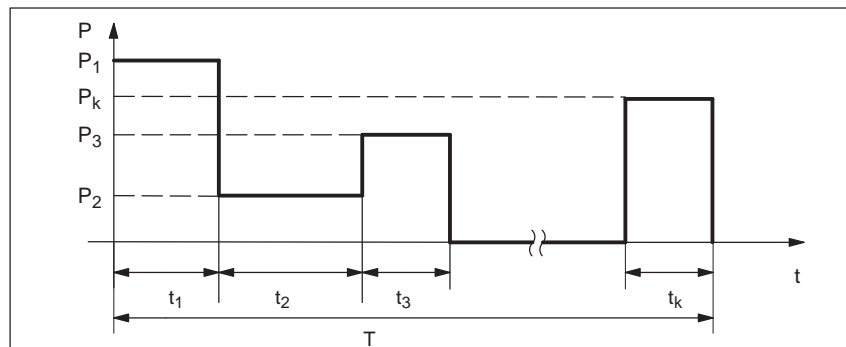

Fig. 6-11 Explanation of the rule of thumb for block-type load duty cycles

The following applies for the rules of thumb:

- The evaluation factor B, calculated for the load duty cycle, must be less than the maximum values  $B_{max}$  specified in Table 6-11.
- The maximum infeed power  $P_{max}$  of the infeed module may not be exceeded.
- The power derating as a function of the installation altitude must be taken into account.

Table 6-11 Evaluation factor for the load duty cycle

	Total duration		
	$T \leq 10 \text{ s}$	$10 \text{ s} < T \leq 60 \text{ s}$	$60 \text{ s} < T \leq 600 \text{ s}$
$B_{max}$	1.03	0.90	0.89

**Calculation example for a block-type load duty cycle:**

Evaluation/assessment factor B should be determined for the following load duty cycle:

Infeed module used: I/R 36 kW ( $P_n=36 \text{ kW}$ ;  $P_{max}=70 \text{ kW}$ )

i	1	2	3	4	5
P [kW]	50	20	36	0	40
t [s]	1.5	1	2	1.2	1.2

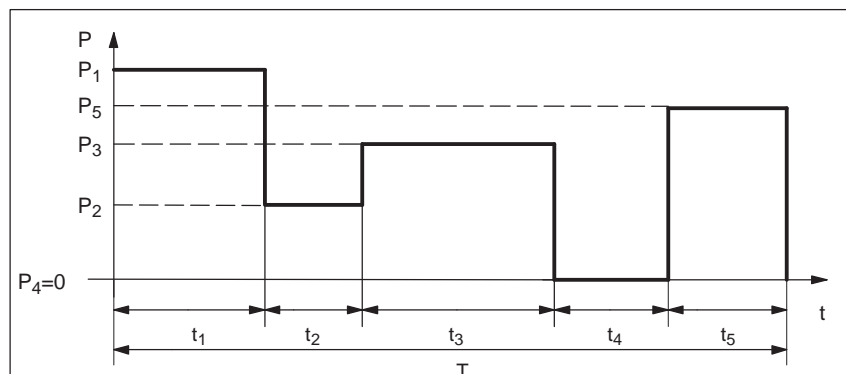

Fig. 6-12 Example, calculating a load duty cycle

1. Is the maximum infeed exceeded? —> No —> OK
2. Calculating the total duration T  
 $T = \sum t_i = t_1 + t_2 + \dots + t_k = 1.5 \text{ s} + 1 \text{ s} + 2 \text{ s} + 1.2 \text{ s} + 1.2 \text{ s} = 6.9 \text{ s}$
3. Calculating the evaluation/assessment factor B

$$B = \sqrt{\frac{P_1^2 \cdot t_1 + P_2^2 \cdot t_2 + \dots + P_k^2 \cdot t_k}{T \cdot P_n^2}}$$

$$B = \sqrt{\frac{50^2 \cdot 1.5 + 20^2 \cdot 1 + 36^2 \cdot 2 + 0^2 \cdot 1.2 + 40^2 \cdot 1.2}{6.9 \cdot 36^2}}$$

$$B = \sqrt{\frac{3750 + 400 + 2592 + 0 + 1920}{8942.4}}$$

$$B = \sqrt{\frac{8662}{8942.4}} = 0.98$$

4. Check, whether B is < B<sub>max</sub> for the calculated load duty cycle T

$$B = 0.98$$

$$B_{\max} \text{ for a load duty cycle less than } 10 \text{ s} = 1.03$$

—> the load duty cycle is permissible.

#### Installation altitude over 1000 m with limitations/secondary conditions

All of the power ratings specified apply up to an installation altitude of 1000 m above sea level. For installation altitudes > 1000 m above sea level, the specified power ratings must be reduced according to the derating characteristic as shown in Chapter 5.4.3. For installation altitudes > 2000 m, an isolating transformer must be used.

For a line supply circuit with overvoltage category III, the standard prescribes greater isolating distances at altitudes starting at 2000 m. For this reason, a non-line supply circuit must be implemented using an isolating transformer.

The isolating transformer is used for uncoupling of a line supply circuit (overvoltage category III) to form a non-line supply circuit (overvoltage category II) in which the available isolating distances are then sufficient.

See IEC 60664-1 (required for the total system).

---

#### Notice

The power ratings for P<sub>n</sub>, P<sub>s6</sub> and P<sub>max</sub> must be reduced (derated) in the same way.

If the power ratings are exceeded, the devices can fail prematurely.

---



---

#### Note

For UI modules, it must be carefully observed that the braking energy fed in does not exceed the power rating of the pulsed resistor.

A defect does not occur; when an overload condition occurs, the resistor is shut down.

The drive unit then goes into a fault condition, with the fault "DC link overvoltage" and the motors coast down in an uncontrolled way.

---

## 6.4 Technical data

## 6.4.3 Technical data of the supplementary components

## Cooling components

Components	Order number	Supply voltage	Supply current	Observe the rotating field!	Degree of protection	Weight [kg]
Built-on fan for internal and external cooling	6SN11 62-0BA02-0AA□	3-ph. 360..510 V AC 45...65 Hz	0.2...0.3 A	For the direction of rotation, refer to the direction of the arrow on the fan	IP 44	4
<u>Hose cooling package 1</u> for an individual module comprising: <ul style="list-style-type: none"> <li>• 2x module connection flange, 2000 mm hose</li> <li>• 1x cabinet connection flange</li> <li>• 1x radial fan with cabinet connection flange<sup>1)</sup> (refer to Fig. 2-7)</li> </ul>	6SN11 62-0BA03-0AA1	3-ph. 360..457 V AC 47.5...62.5 Hz	1.0...1.2 A	Counter-clockwise direction of rotation when viewing the rotor	IP 54	8
<u>Hose cooling package 2</u> for a 2-tier configuration of I/R 55 kW and LT 200 A: <ul style="list-style-type: none"> <li>• 4x module connection flange, 2000 mm hose</li> <li>• 1x cabinet connection flange</li> <li>• 1x radial fan with cabinet connection flange<sup>1)</sup> (refer to Fig. 2-7)</li> </ul>	6SN11 62-0BA03-0CA1	3-ph. 360..457 V AC 47.5...62.5 Hz	1.0...1.2 A	Counter-clockwise direction of rotation when viewing the rotor	IP 54	8
Motor circuit-breaker	Size S00: Setting value, 0.3 A                      3RV1011-0DA10 0.22–0.32 A Setting value, 1 A                         3RV1011-0KA10 0.9–1.25 A  Size S0 Setting value, 0.3 A                      3RV1021-0DA10 0.22–0.32 A Setting value, 1 A                         3RV1011-0KA10 0.9–1.25 A					
Air baffle plate width 100 mm	6SN1162-0BA01-0AA0	If heat sensitive parts are located above the UI and/or PR module with a clearance < 500 mm, e.g. cable ducts, then an air baffle plate must be used (refer to Chapter 12, Dimension drawings).				

1) Replacement filter element:

Order No. AFF0  
Can be ordered from: Pfannenberg GmbH  
Postfach 80747  
D-21007 Hamburg

**Warning**

The fan may only be commissioned if it is electrically connected to the module housing (PE fan via module housing).

**Caution**

If the fan has the incorrect direction of rotation (refer to the arrow on the fan) then cooling is not guaranteed!

### Connection for 3-phase fans

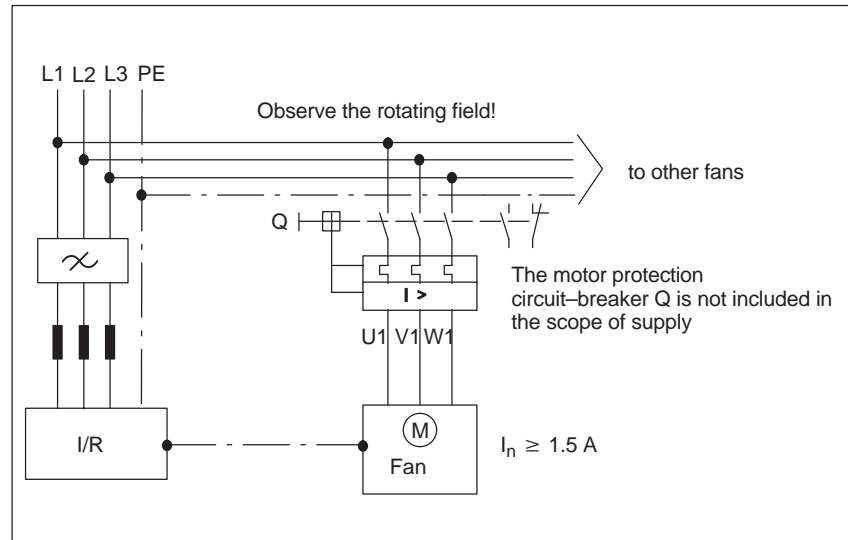

Fig. 6-13 Connection for 3-phase fans

## 6.5 HFD reactor

### General information

For the unregulated 5 kW and 10 kW infeed modules, the commutating reactor is integrated. With 28 kW, it must be external.

For connection of the regulated infeed/regenerative feedback modules to the line supply, the HF/HFD reactor tuned to 7 kHz is required (see selection Table 6-12).

The HFD reactors perform the following functions:

- To limit the harmonics fed back into the line supply
- Energy store for the step-up operation of the infeed units
- Current limiting for line supply oscillations
- Together with a damping resistor, the HFD reactors dampen the system oscillations of the converter system. The HF reactors are replaced with the HFD reactors with damping resistor because they provide increased operational reliability and a longer lifetime.

The HFD reactor should be mounted as close as possible to the line supply infeed module.



### Caution

The surface of the reactors can reach high temperatures.

The 100 mm clearance above and below the components to ensure air circulation and cooling must be carefully maintained. If this is not observed, then the components could prematurely age.

Temperature-sensitive components must be located a sufficient distance away or thermally partitioned off!

### Note

The connecting cables to the NE module must be kept as short as possible (max. 5 m). For lengths exceeding 1 m, twisted shielded connection lines, with the shielding contacting ground on both side, should be used. It is preferable that the cable shield is connected close to the reactor footplate, using a clamp that completely encompasses the shield

### Notice

It is not permissible to use HFD reactors in the motor cable. Operation without a damping resistor is not permissible, as high voltages (several kV) can occur if the system oscillates

### Note

If commutating reactors are used that have not been released by SIEMENS for SIMODRIVE 6SN11, harmonics or switching edges not permitted for the semiconductors can occur that can damage, disturb or early age other equipment connected to the particular line supply.

### 6.5.1 Assignment of the HFD reactors/damping resistors to the NE modules

Table 6-12 HFD reactor/damping resistor assignment, data

	UI module 28/50 kW	I/RF module 16/21 kW	I/RF module 36/47 kW	I/RF module 55/71 kW	I/RF module 80/104 kW	I/RF module 120/156 kW
Type HFD reactor	28 kW	16 kW	36 kW	55 kW	80 kW	120 kW
Order No. 6SL3000– 6SN1111–	– 1AA00–0CA□	0DE21–6AA□	0DE23–6AA□	0DE25–5AA□	0DE28–0AA□	0DE31–2AA□
Pv	70 W	170 W	250 W	350 W	450 W	590 W
Degree of protection acc. to DIN EN 60529 (IEC 60529)	IP00					
Maximum permissible ambient temperature	<ul style="list-style-type: none"> <li>• Transport –25..+80 °C</li> <li>• Storage –25..+80 °C</li> <li>• Operation 0...+40 °C, for power derating, up to +55 °C</li> </ul>					
Connection	max. 35 mm <sup>2</sup>	max. 16 mm <sup>2</sup>	max. 35 mm <sup>2</sup>	max. 70 mm <sup>2</sup>	max. 95 mm <sup>2</sup>	
Tightening torque of terminals [Nm]	2.5	1.2	2.5	Conductor 7 PE 3...4	Spring-loaded terminals	
	Terminals of HFD resistor 1.2					
Approx. weight	6 kg	8.5 kg	13 kg	18 kg	40 kg	50 kg
Mounting position	Any	Any	Any	Any	Any	Any
Terminal placement	Input: 1U1, 1V1, 1W1					
	Output: 1U2, 1V2, 1W2					
HFD damping resistor	–	Refer to Table 6-15				
Cooling clearances (without any additional measures, HFD line reactors can become hot!):	100 mm					
Drilling template	Refer to Chapter 12 Dimension drawings					



## 6.5 HFD reactor

**HFD packages**

The following usual HFD components can be ordered in packages:

- HFD package includes an HFD line reactor and a damping resistor

Table 6-13 Packages without Wideband Line Filter that can be ordered

For I/R modules	HFD package	HFD line reactor	Damping resistor
16 kW	6SN1111-0AA00-0BV0	6SL3000-0DE21-6AA□	6SN1113-1AA00-0DA□ (300 W)
	6SN1111-0AA00-0BV1		6SL3100-1BE21-3AA□ (800 W)
36 kW	6SN1111-0AA00-0CV0	6SL3000-0DE23-6AA□	6SN1113-1AA00-0DA□ (300 W)
	6SN1111-0AA00-0CV1		6SL3100-1BE21-3AA□ (800 W)
55 kW	6SN1111-0AA00-0DV0	6SL3000-0DE25-5AA□	6SL3100-1BE21-3AA□ (800 W)
80 kW	6SN1111-0AA00-0EV0	6SL3000-0DE28-0AA□	6SL3100-1BE21-3AA□ (800 W)
120 kW	6SN1111-0AA00-0FV0	6SL3000-0DE31-2AA□	6SL3100-1BE21-3AA□ (800 W)

- HFD package includes an HFD line reactor, a damping resistor and a Wideband Line Filter

Table 6-14 HFD packages with Wideband Line Filter that can be ordered

For I/R modules	HFD package	HFD line reactor	Damping resistor	Wideband Line Filter
16 kW	6SN1111-0AA00-1BV0	6SL3000-0DE21-6AA□	6SN1113-1AA00-0DA□ (300 W)	6SL3000-0BE21-6AA□
	6SN1111-0AA00-1BV1		6SL3100-1BE21-3AA□ (800 W)	
36 kW	6SN1111-0AA00-0CV0	6SL3000-0DE23-6AA□	6SN1113-1AA00-0DA□ (300 W)	6SL3000-0BE23-6AA□
	6SN1111-0AA00-0CV1		6SL3100-1BE21-3AA□ (800 W)	
55 kW	6SN1111-0AA00-0DV0	6SL3000-0DE25-5AA□	6SL3100-1BE21-3AA□ (800 W)	6SL3000-0BE25-5AA□
80 kW	6SN1111-0AA00-0EV0	6SL3000-0DE28-0AA□	6SL3100-1BE21-3AA□ (800 W)	6SL3000-0BE28-0AA□
120 kW	6SN1111-0AA00-0FV0	6SL3000-0DE31-2AA□	6SL3100-1BE21-3AA□ (800 W)	6SL3000-0BE31-2AA□

**HFD reactor connection**

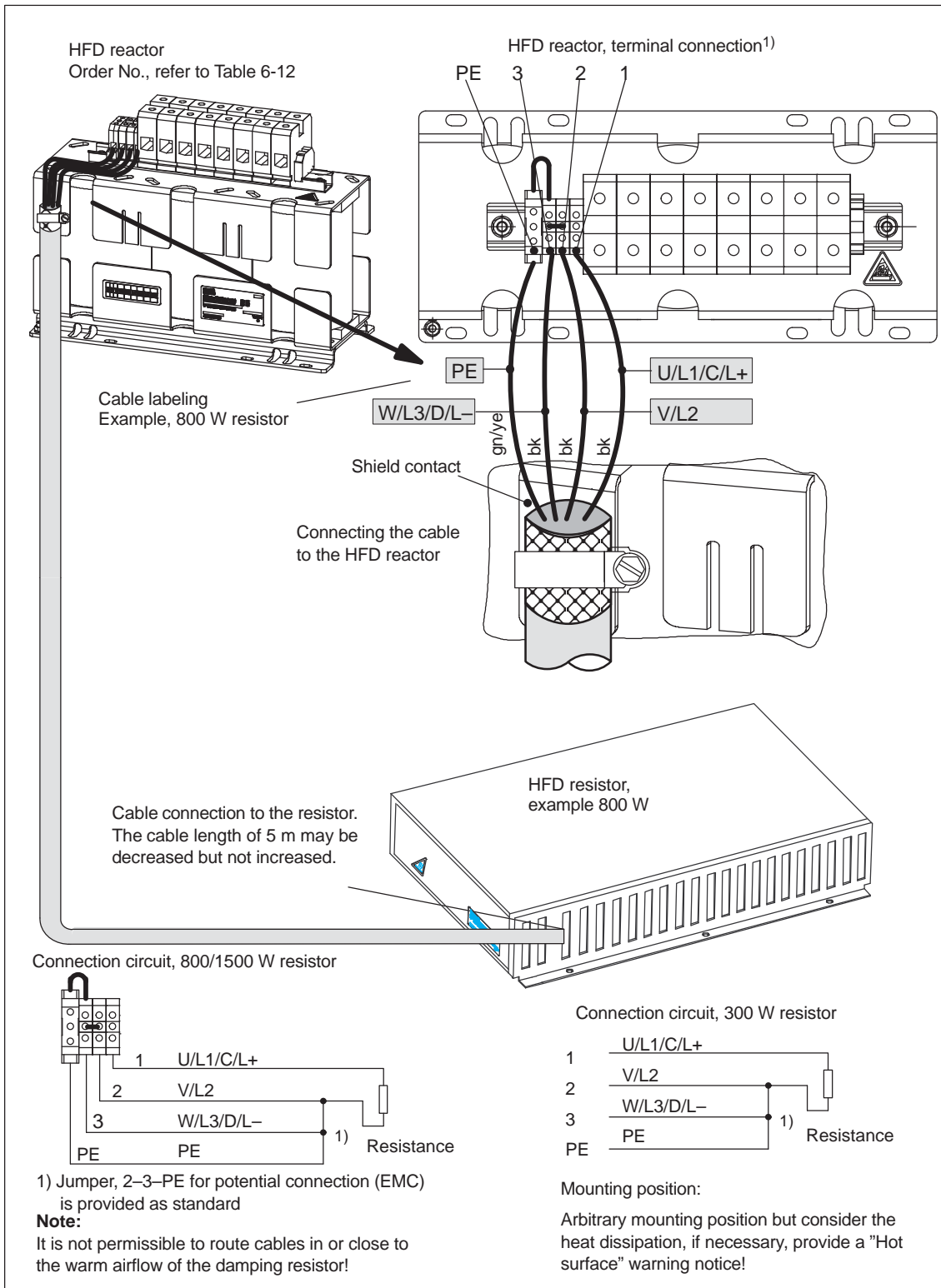

Fig. 6-14 Wiring, HFD reactor and damping resistor

## 6.5 HFD reactor

**Damping resistor**

Together with the HFD reactor, an external resistor must be used for damping purposes (refer to Fig. 6-14).

Table 6-15 Technical specifications

	<b>Pulsed resistor 0.3/25 kW<sup>1)</sup></b>	<b>HFD damping resistor<sup>2)</sup></b>	<b>Pulsed resistor Plus 1.5/25 kW<sup>3)</sup></b>
<b>Order No.</b>	6SN1113-1AA00-0DA□	6SL3100-1BE21-3AA□	6SL3100-1BE22-5AA□
Rated power (kW)	0.3	0.8	1.5
Special low-inductance resistor	0...230 kHz ≤ 3 dB		
including the connecting cable [m]	3	5	5
Connection	3 x 1.5 mm <sup>2</sup>	4 x 1.5 mm <sup>2</sup>	4 x 2.5 mm <sup>2</sup>
Weight [kg]	1.45	5.5	5.6
Degree of protection acc. to DIN EN 60529 (IEC 60529)	IP 54	IP51	IP20
UL file	E-228809	E-212934	E-192450
Ambient temperature [°C]	0...55		
Dimensions (W x H x D) [mm]	80 x 210 x 53	277 x 552 x 75	193 x 410 x 240

- 1) The 300 W resistance can be used for HFD applications if the following is true after a warm-up run when all axes are shut down in a regulated way:
- After an operating period of over two hours, no temperature in excess of 150 °C may occur on the surface of the 6SN1113-1AA00-0DA0 resistor.
  - This warm-up run must be repeated if the hardware configuration, e.g. motor cable lengths, is changed!
- 2) Preferred type  
3) Alternative possible

**Note**

Preferably, the HFD damping resistor (6SL3100-1BE21-3AA0) should be used. It must not be connected as an external pulsed resistor on the pulsed resistor module or UI module!

The HFD damping resistor can become very hot. Consequently, it must be installed so that it cannot be touched or placed at an endangered position with an appropriate warning notice.

**Danger**

During operation and briefly after being switched off, the surfaces can reach temperatures that can cause burns and results in fires

**Reader's note**

For mounting information and instructions for external HFD resistors, refer to Fig. 6-14 and Chapter 6.7.4.

## 6.6 Monitoring module

### 6.6.1 Integration into the overall system

The monitoring module contains an electronic power supply and central monitoring functions, which are required to operate the drive modules.

### 6.6.2 Technical data (supplement to the general technical data)

Table 6-16 Technical data, monitoring module

Power loss	70 W
Rated supply voltage	3-ph. 400 V – 10% up to 480 V AC + 6%
Alternatively, rated supply voltage DC link	600/625/680 V DC
Current consumption	for 3-ph. 400 V AC: approx. 600 mA
Type of cooling	Natural ventilation
Weight	approx. 5 kg
Assessment factor for the electronic points (EP)	Max. 8
Assessment factor for the gating points (AP)	Max. 17
The cross-section that can be connected to the P600, N600, X131 terminal block	<ul style="list-style-type: none"> <li>• Max 10 mm<sup>2</sup> for cables with conductor end sleeves</li> <li>• Max 16 mm<sup>2</sup> for cables with pin-type cable lug</li> </ul>



#### Reader's note

For an overview of the interfaces, refer to Section 6.2.1, Table 6-1 in the column "Terminals used" under monitoring module.

For operation of the monitoring module only on the DC link, without AC power supply, 1000 µF per monitoring module must be observed for the loading limit of the line supply.

This capacity is not included in the calculation of the permitted number of pulsed resistors, because they are de-coupled using diodes.

6.6 Monitoring module

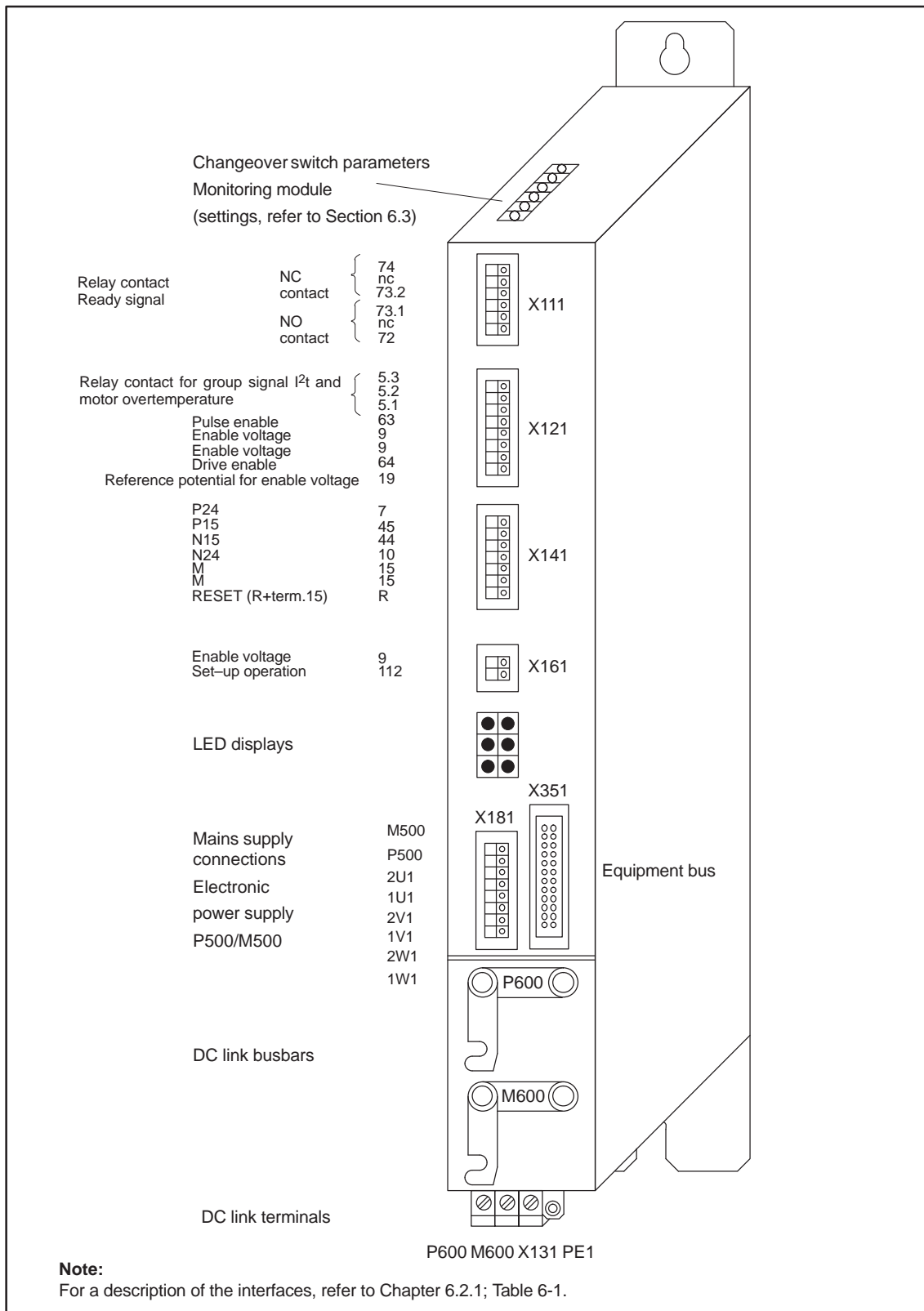

Fig. 6-15 Monitoring module 6SN1112-1AC01-0AA1

### 6.6.3 Mode of operation

Parameters critical for operation are monitored in the monitoring module – these include:

- DC link voltage
- Controller power supply ( $\pm 15$  V)
- 5 V voltage level

If these parameters are in the permissible operating range, then the internal prerequisites for the "Unit ready" signal are available. The module group connected to the monitoring module is enabled as soon as the external enable signals have been issued via terminals 63 (pulse enable) and 64 (drive enable). The total signal activates the "Ready" relay and can be fetched potential-free using the 74/73.2 and 73.1/72 terminals. The load capability of the contacts is 250 V AC/1 A or 30 V DC/1 A.

LEDs on the front panel of the monitoring module indicate the signal states of the monitoring circuits.

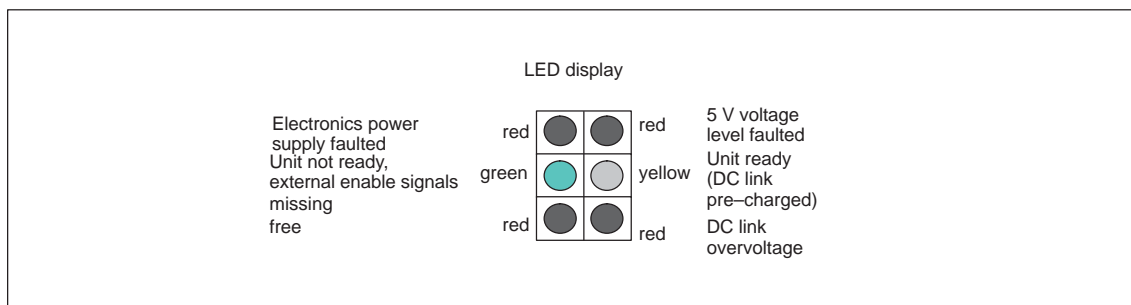

Fig. 6-16 LED display of the monitoring module

6.6 Monitoring module

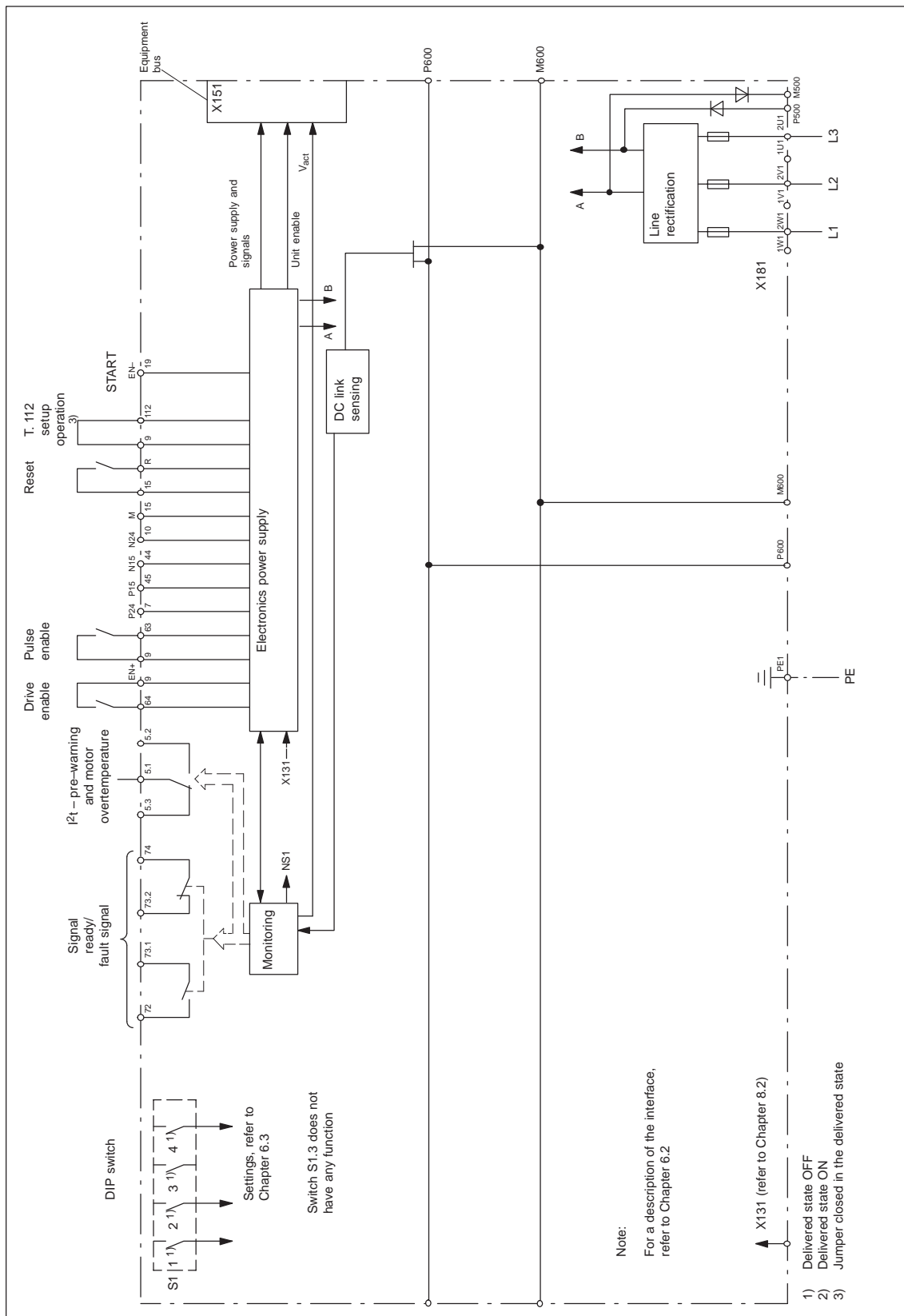

Fig. 6-17 Block diagram, monitoring module

## 6.7 DC link options

### 6.7.1 Capacitor module with 2.8 mF, 4.1 mF or 20 mF

#### Description

The capacitor modules are used to increase the DC link capacitance. This means that on one hand, a brief power failure can be buffered and on the other hand, it is also possible to store the braking energy.

A differentiation is made between the modules as follows:

- Modules with 2.8 mF and 4.1 mF → are used as dynamic energy storage devices
- Module with 20 mF → is used to buffer line supply dips

The modules are available in the following versions:

- Central modules: 4.1 mF and 20 mF
  - SIMODRIVE housing type – integrated into the system group.
- Distributed modules: 2.8 mF and 4.1 mF
  - New housing types are mounted decentrally in the control cabinet and are connected to the SIMODRIVE DC link using an adapter terminal and cable.

The capacitor modules have a ready display; this is lit from a DC link voltage of approximately 300 V and above. This also means that if an internal fuse ruptures, it can be identified. This does not guarantee safe and reliable monitoring of the charge state.

The module with 2.8 mF or 4.1 mF is implemented without pre-charging circuit and can – because it is directly connected to the DC link – absorb dynamic energy and therefore operate as dynamic energy storage device. For these modules, the charge limits of the line supply modules must be carefully taken into consideration.

For the 20 mF module, the pre-charging is realized through an internal pre-charging resistor; this is designed to limit the charge current and to de-couple the module from the central pre-charging function. This module cannot dynamically absorb any energy as the pre-charging resistor limits the charge current. When the power fails (line supply failure), a diode couples this capacitor battery to the system DC link so that it can be buffered by the capacitors.

---

#### Note

The capacitor modules may only be used in conjunction with the SIMODRIVE 611 line supply infeed units.

The central modules are suitable for internal and external cooling.

---



## 6.7 DC link options

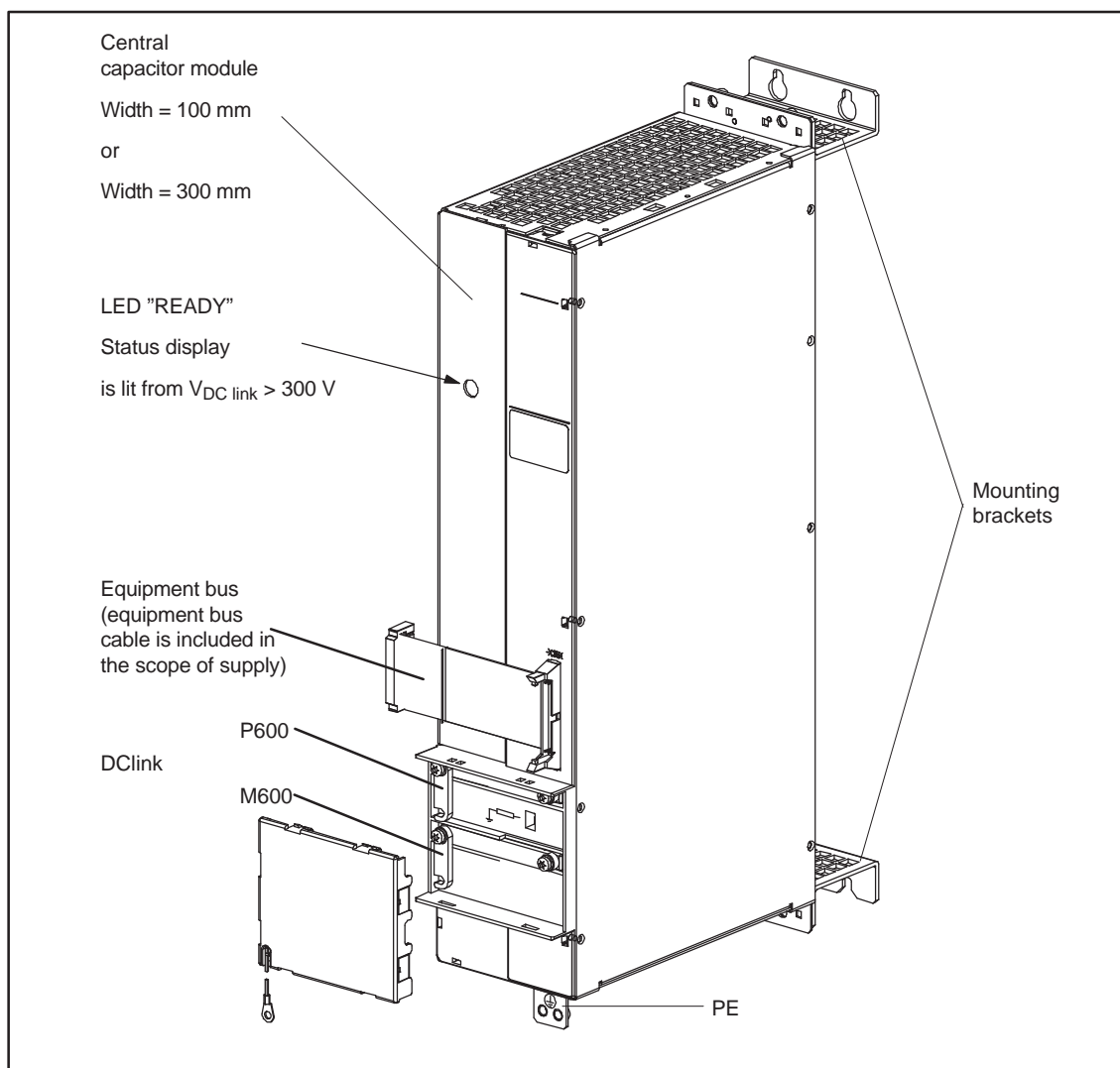

Fig. 6-18 Central capacitor module 4.1 mF

**Note**

The equipment bus is only looped through the capacitor module and has no function in the module itself. If capacitor modules are mounted at the end of the module lineup, then the equipment bus does not have to be wired.

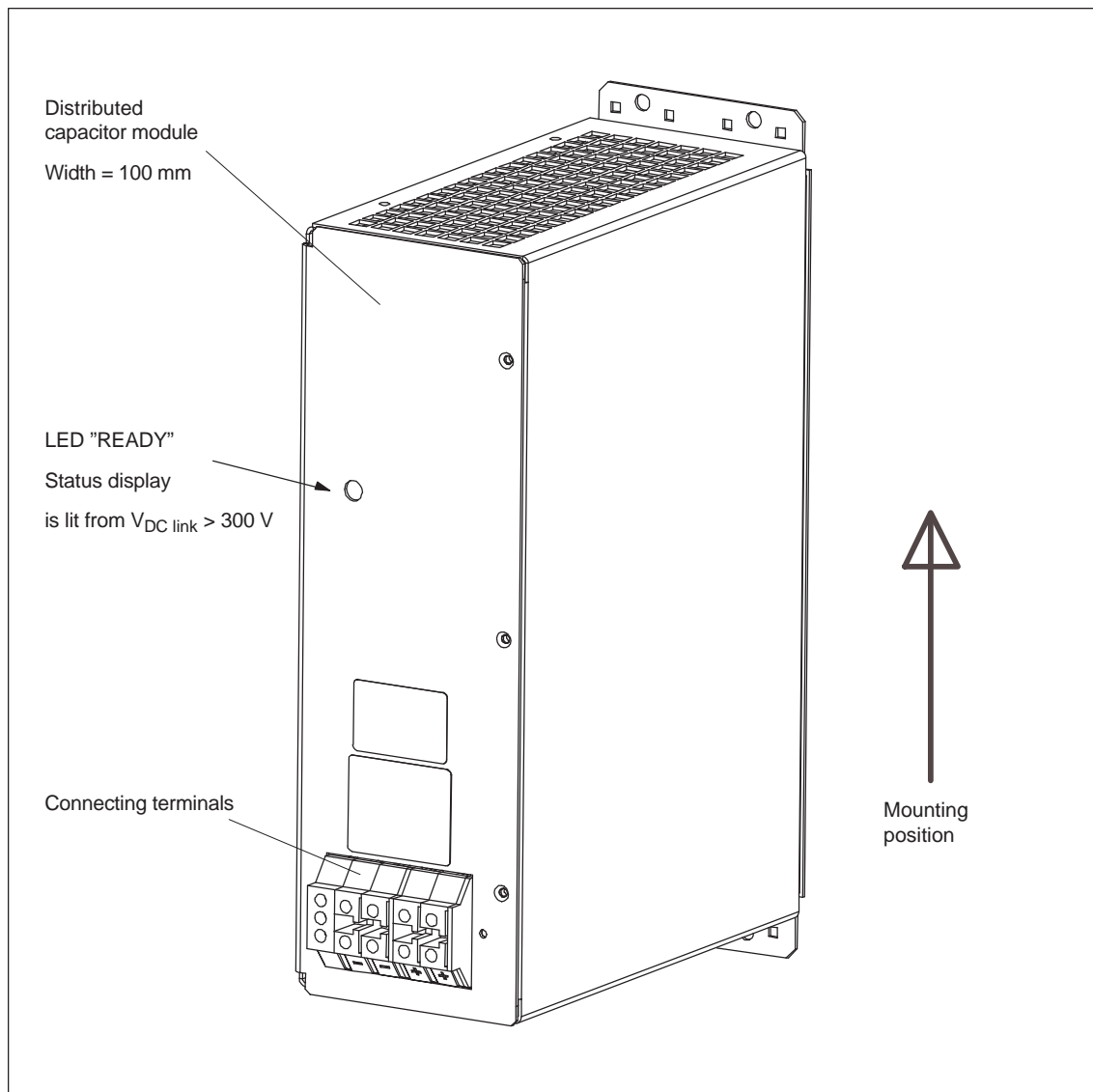

Fig. 6-19 Distributed capacitor module, 2.8 mF/4.1 mF

## 6.7 DC link options

## Technical data

The following technical data applies:

Table 6-17 Technical data of the central capacitor modules

Designation	Central modules	
	4.1 mF	20 mF
Order number	6SN11 12-1AB00-0BA0	6SN11 12-1AB00-0BA0
Voltage range	$V_{DC}$ 350 ... 750 V	
Storage capacity $w = 1/2 \times C \times V^2$	$V_{DC}$ steady-state (examples) 600 V → 738 Ws 680 V → 948 Ws	$V_{DC}$ steady-state (examples) 600 V → 3 215 Ws 680 V → 4 129 Ws Note: As a result of the internal pre-charging resistor, the voltage at the capacitors is only approx. $0.94 \times V_{DC}$ .
Temperature range	0 °C to +55 °C	
Weight	approx. 7.5 kg	approx. 21.5 kg
Dimensions	W x H x D 100 x 480 x 211 [mm]	W x H x D 300 x 480 x 211 [mm]

Table 6-18 Technical data of the distributed capacitor modules

Designation	Distributed modules	
	2.8 mF	4.1 mF
Order number	6SN11 12-1AB00-1AA0	6SN11 12-1AB00-1BA0
Voltage range	$V_{DC}$ 350 ... 750 V	
Storage capacity $w = 1/2 \times C \times V^2$	$V_{DC}$ steady-state (examples) 600 V → 504 Ws 680 V → 647 Ws	$V_{DC}$ steady-state (examples) 600 V → 738 Ws 680 V → 948 Ws
Temperature range	0 °C to +55 °C	
Weight	5.3 kg	5.8 kg
Dimensions	W x H x D 100 x 334 x 231 [mm]	W x H x D 100 x 334 x 231 [mm]
Connection	AWG 12 ... AWG 6 (4 ... 16 mm <sup>2</sup> ) finely stranded	
Degree of protection	IP 20	

## Examples for the calculation

The storage capacity in dynamic operation and for regenerative braking is calculated as follows:

$$\text{Formula: } w = \frac{1}{2} \cdot C \cdot (V_{DC \text{ link max}}^2 - V_{DC \text{ link n}}^2)$$

Assumptions for the example:

Capacitance of the capacitor battery  $C = 4.1 \text{ mF}$

Rated DC link voltage  $V_{DC \text{ link n}} = 600 \text{ V}$

Maximum DC link voltage  $V_{DC \text{ link max}} = 695 \text{ V}$

$$\rightarrow w = \frac{1}{2} \cdot 4.1 \cdot 10^{-3} \text{ F} \cdot ((695 \text{ V})^2 - (600 \text{ V})^2) = 252 \text{ Ws}$$

In addition, 252 Ws for each  $C = 4.1 \text{ mF}$  module can be stored for this voltage range.

**The following applies for the storage capacity of the capacitor battery when the power fails:**

Formula:  $w = \frac{1}{2} \cdot C \cdot (V_{\text{DC link n}}^2 - V_{\text{DC link min}}^2)$

Assumptions for the example:

Capacitance of the capacitor battery  $C = 20 \text{ mF}$

Rated DC link voltage  $V_{\text{DClinkn}} = 600 \text{ V}$

Minimum DC link voltage  $V_{\text{DClinkmin}} = 350 \text{ V}$

—>  $w = \frac{1}{2} \cdot 20 \cdot 10^{-3} \text{ F} \cdot ((600 \text{ V})^2 - (350 \text{ V})^2) = 2375 \text{ Ws}$

For this voltage range, a 20 mF capacitor module can supply energy for 2375 Ws.

---

**Notice**

$V_{\text{DClinkmin}}$  must be  $\geq 350 \text{ V}$ .

For voltages below 350 V, the switched-mode power supply for the electronics shuts down.

---

The possible buffer time  $t_{\text{Ü}}$  is calculated as follows with the output DC link power  $P_{\text{DC link}}$ :

$$t_{\text{Ü}} = w / P_{\text{DC link}}$$

**Dynamic energy**

The DC link capacitors should be considered as being a battery. The capacitance and, thus, the storage capacity are increased as a result of the capacitor module.

In order to evaluate the required capacitance for a specific requirement in a certain application, the energy flow must be determined.

The energy flow depends on the following:

- All moved masses and moments of inertia
- Velocity, speed (and their change, acceleration, deceleration)
- Efficiencies: Mechanical system, gear units, motors, inverters (driving/braking)
- Back-up duration, buffering
- DC link voltage and the permissible change, output value, upper/lower limit value.

In practice, often there is no precise data about the mechanical system. If the mechanical system data is determined using rough calculations or estimated values, then the capacitance of the DC link capacitors required can only be determined during tests performed during the commissioning phase.

**The energy for dynamic operations is obtained as follows:**

The following applies for braking or accelerating operations within time  $t_V$  of a drive from one speed/velocity to another:

$$w = \frac{1}{2} \cdot P \cdot t_V$$

For rotary drives with

$$P = \frac{M_{Mot} \cdot (n_{Mot \max} - n_{Mot \min})}{9\,550} \cdot \eta_G$$

For linear drives with

$$P = F_{Mot} \cdot (V_{Mot \max} - V_{Mot \min}) \cdot 10^{-3} \cdot \eta_G$$

with  $\eta_G$ :

Braking  $\eta_G = \eta_M \cdot \eta_{INV}$

Acceleration  $\eta_G = 1/(\eta_M \cdot \eta_{INV})$

$w$ [Ws]	Energy
$P$ [kW]	Motor power
$t_V$ [s]	Time of the operation
$M_{mot}$ [Nm]	Max. motor torque when braking or accelerating
$F_{mot}$ [N]	Max. motor force when braking or accelerating
$n_{mot \max}$ [RPM]	Max. speed at the start or the end of the operation
$n_{mot \min}$ [RPM]	Min. speed at the start or end of the operation
$v_{mot \max}$ [m/s]	Max. velocity at the start or end of the operation
$v_{mot \min}$ [m/s]	Min. velocity at the start or end of the operation
$\eta_G$	Total efficiency
$\eta_M$	Motor efficiency
$\eta_{INV}$	Inverter efficiency

Torque  $M$  and force  $F$  depend on the moved masses, the load, and the acceleration in the system.

If precise data is not available for the previously specified factors, then generally rated/nominal data is used instead.

**Engineering information**

The central capacitor module should preferably be located at the end of the system group. The connection is made using the DC link busbar.

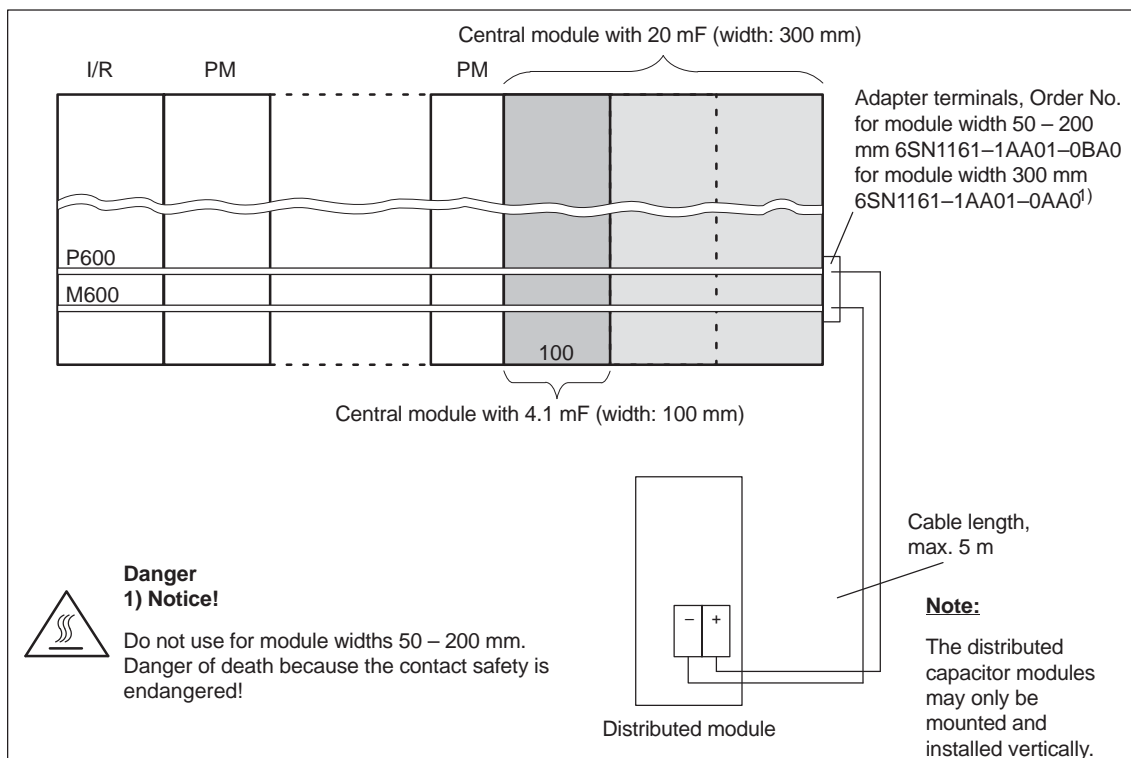

Fig. 6-20 Mounting location for the capacitor modules

Depending on the line infeed used, several capacitor modules can be connected in parallel.

For the capacitor modules with 2.8 mF and 4.1 mF, the total charge limit of the line infeed may not be exceeded (refer to Chapter 1.3).

### Capacitor modules that can be connected

The capacitor modules 2.8 mF and 4.1 mF (central/distributed) must be dimensioned/selected corresponding to the engineering table 1-4 in Chapter C.1.1 taking into account the charge limits of the infeed.

The 20 mF capacitor modules do not have to be taken into account in the 1-4 engineering table. They must be selected as required taking into account the maximum number from Table 6-19.

Table 6-19 Maximum number of 20 mF capacitor modules

Infeed unit	Maximum that can be connected <sup>1)</sup>
UI 5 kW	1
UI 10 kW I/R 16 kW	3
UI 28 kW I/R 36 kW...120 kW	5

1) Valid if all of the monitoring modules used are connected to the AC line supply.

## 6.7 DC link options

**Charge times**  
**Discharge times**  
**Discharge voltage**

Before performing any commissioning or service work, check that the DC link is safely disconnected from the power supply.

Table 6-20 Charge/discharge times, discharge voltage

Capacitor module	The charge time depends on the total DC link capacitance	The discharge time depends on the total DC link capacitance to 60 V of the DC link voltage at 750 V DC
2.8 mF/4.1 mF	As for the power modules	approx. 30 min
20 mF	approx. 2 min	approx. 30 min

If there is a pulsed resistor in the system, in order to reduce the discharge time after opening terminal 48, the DC link can be quickly discharged via terminals X221:19 and 50 (jumpers). In this case, the electronics power supply must be implemented using a 3-phase line supply connection; this is not disconnected while discharging.

**Note**

Discharge through a pulsed resistor is not possible for a 5 kW UI!

**Warning**

The pulsed resistor modules can only convert a certain amount of energy into heat (refer to Table 6-24). The energy available to be converted depends on the voltage.

A monitoring function protects the resistance against overload. If this responds, then no additional energy is converted into heat in the resistor.

**Caution**

In order to avoid damage to the infeed circuit of the NE modules, when controlling/energizing terminal X221 T.19/50, it should be ensured that terminal 48 of the NE module is deenergized (the module is electrically isolated from the line supply).

The feedback signal contacts of the main contactor of the NE module must be evaluated to check whether the contactor has actually dropped out (X161 terminal 111, terminal 113 and terminal 213).

## 6.7.2 Pulsed resistor module and unregulated line supply infeed with pulsed resistor

The pulsed resistor module (PR module) protects the DC link from overvoltage, which, for example, would occur for UI modules when braking or for I/R modules when the power fails when stopping. The possible braking power of the total system can be increased by using one or more pulsed resistor modules.

The pulsed resistor module can be used to quickly discharge the DC link.

If the pulsed resistor (PR) module is supplied from a monitoring module, the electronics power supply must be implemented with a 3-phase AC supply system. Fast discharge is not possible if the electronics power supply is exclusively implemented through the DC link (P500/N500).

If heat-sensitive components, e.g. cable ducts, are located above the module with a clearance < 500 mm, then an air baffle plate must be provided (Order No. 6SN1162-0BA01-0AA0).

As a result of the universal housing design of the pulsed resistor module, this can be used both for internally as well as externally cooled module groups.

The UI and PR modules are equipped with a switch-on time monitoring; this protects the pulsed resistor from overheating.

The switch-in and switch-out thresholds depend on the setting of the line infeed switch S 1.1 or S 1.4, see Chapter 6.3.

Table 6-21 Technical data, PR module

Rated supply voltage	435/490/600/625/680 V DC
Continuous power/peak power/energy Permitted load cycle, refer to Section 6.7.4	<ul style="list-style-type: none"> <li>with internal pulsed resistor P = 0.3/25 kW; E = 7.5 kW</li> <li>with an external pulsed resistor module P = 1.5/25 kW; E = 13.5 kW</li> </ul>
Weight	approx. 5 kg
Module width	50 mm
Order number	6SN11 13-1AB01-0AA1



## 6.7 DC link options

### Connection PR module

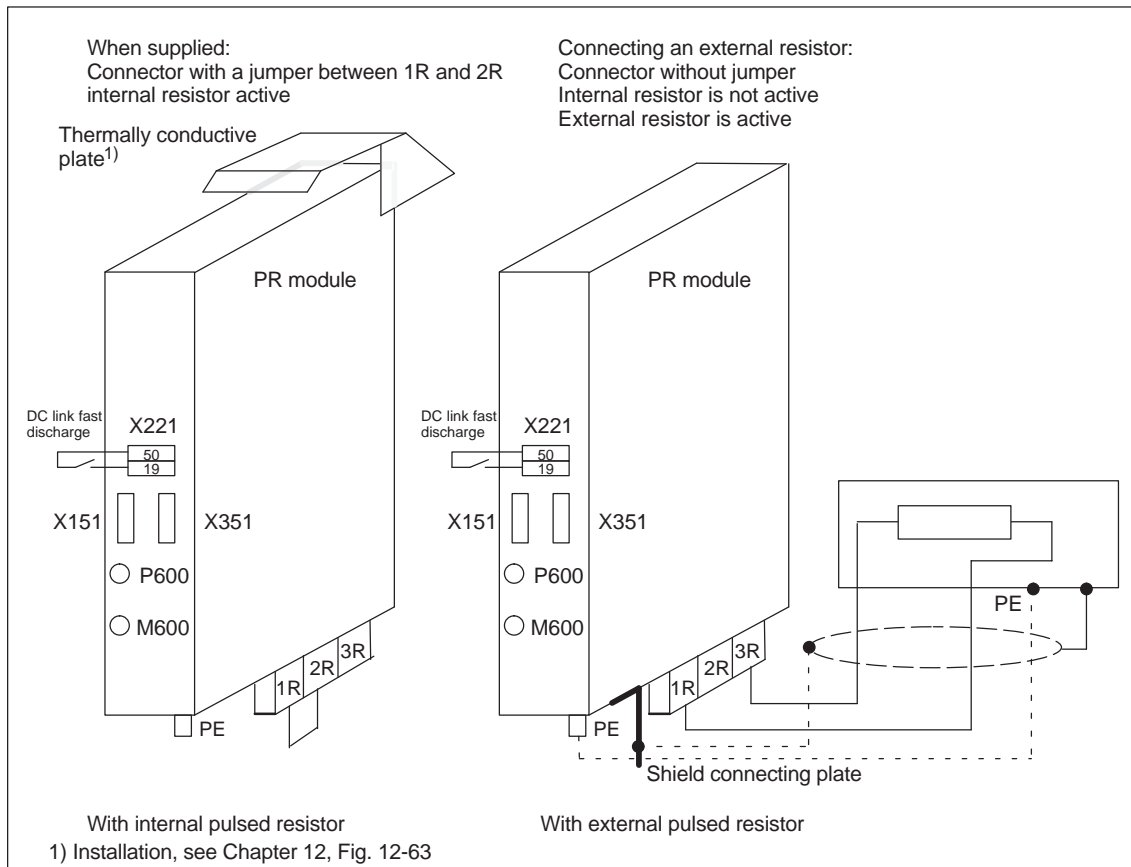

Fig. 6-21 PR module, Order No.: 6SN1113-1AB01-0BA□

**Note**

Only the external PR 6SL3 100-1BE22-5AA0 can be connected.

**Notice**

Fast discharge is possible only when a 3-phase AC line supply is present!

Table 6-22 Interface description for PR modules

Term. No.	Designation	Function	Type 1)	Max. cross-section
PE P600 M600		Protective conductor DC link DC link	I I/O I/O	Screw Busbar Busbar
	X151/X351	Equipment bus	I/O	Ribbon cable
1R, 2R, 3R	TR1, – TR2	Connection of an external resistor (remove the 1R – 2R jumper!)	I/O	6 mm <sup>2</sup> /4 mm <sup>2</sup> 2)
19 50	X221 X221	Reference potential 0 V Fast discharge = 0 V	O,P I	1.5 mm <sup>2</sup> 1.5 mm <sup>2</sup>

1) I = input; O = output; P = only for PELV voltage

2) The first data is used for pin-type cable lug.

The second data is used for finely-stranded conductors without end sleeve.

### Number of pulsed resistors used on the same DC link

The following condition must be fulfilled:

$$T = R_{\Sigma N} \cdot C_{DC \text{ link}} \geq 7.5 \text{ ms}$$

$$1/R_{\Sigma N} = 1/R1 + 1/R2 + 1/R3 + \dots + 1/Rn$$

$R_{\Sigma N}$  Resistance of the parallel-connected resistors in the system  
(15 ohm/resistor)

$C_{DC \text{ link}}$  [μF] Total of all DC link capacities of the drive group

Secondary condition:

$C_{DC \text{ link}}$  with pulsed resistor of at least 500 μF per resistor

### Note

For a module group with pulsed resistor modules, they must be operated on the same power supply (device bus) of the I/R or monitoring module to ensure a simultaneous activation and deactivation of the resistors. Otherwise individual resistors/pulsed resistance modules can be overloaded.

For UI modules that use the integrated pulsed resistors, additional pulsed resistor modules must be operated on the device bus (PS) of the UI module!

An additional pulsed resistor module is not permitted for the 5 kW UI module!

### 6.7.3 External pulsed resistors

With externally attached pulsed resistors, the power loss of the resistor that occurs during braking accumulates outside the control cabinet and, thus, does not place a thermal load on the control cabinet.

The external pulsed resistors are generally required for the 28 kW UI module.

Depending on the power requirement, up to two equal pulsed resistors can be connected in the case of the 28 kW UI module. The protection function is parameterized via the connecting terminals.

Table 6-23 Technical specifications

Data	External pulsed resistor	
	0.3/25 kW (15 Ω)	Plus 1.5/25 kW (15 Ω)
Order number	6SN1113-1AA00-0DA0 (only for 28 kW UI module/ HFD)	6SL3100-1BE22-5AA0
Degree of protection acc. to DIN EN 60529 (IEC 60529)	IP54	IP20
Weight [kg]	3.4	5.6
Type of cooling	Natural ventilation	Natural ventilation
Dimensions (W x H x D) [mm]	80 x 210 x 53	193 x 410 x 240
including the connecting cable [m]	3	5

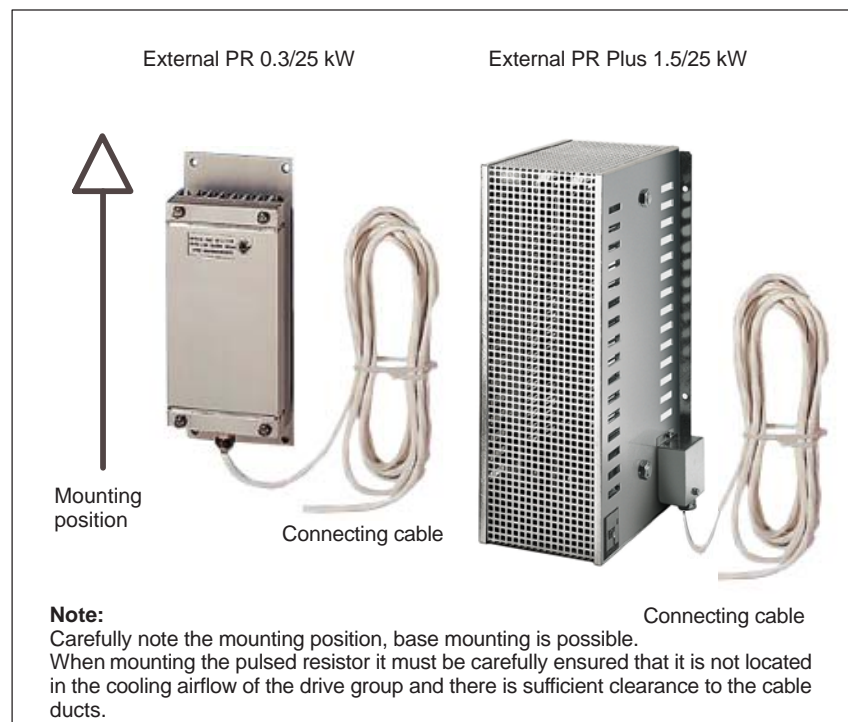

Fig. 6-22 Pulsed resistor, external

Table 6-24 Braking power of the UI and pulsed resistor modules (PR)

Description	External PR 0.3/25 kW <sup>1)</sup>	External PR Plus 1.5/25 kW
Order number	6SN1113-1AA00-0DA0	6SL3100-1BE22-5AA0
Can be used for	28 kW UI module	28 kW UI module PR module 6SN1113-1AB0□-0BA□ <ul style="list-style-type: none"> <li>Attenuation: 0...230 kHz ≤ 3 dB</li> <li>Must be used together with HFD commutating reactor for damping</li> </ul>
P <sub>n</sub>	0.3 kW	1.5 kW
P <sub>max</sub>	25 kW	25 kW
E <sub>max</sub>	7.5 kW <sub>s</sub>	180 kW <sub>s</sub>
Dimension drawings, refer to Chapter 12		

1) External PR can also be used for damping after a protecting measurement on the HFD reactor.

### Mounting positions

The resistor can be mounted either horizontally or vertically.

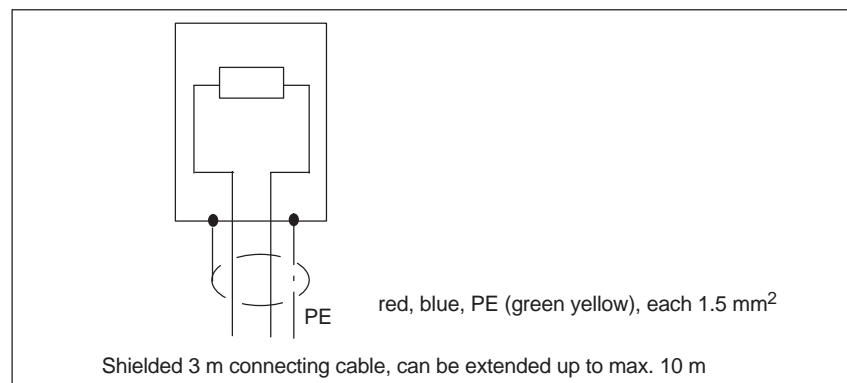

Fig. 6-23 Connection for external pulsed resistor 0.3/25 kW

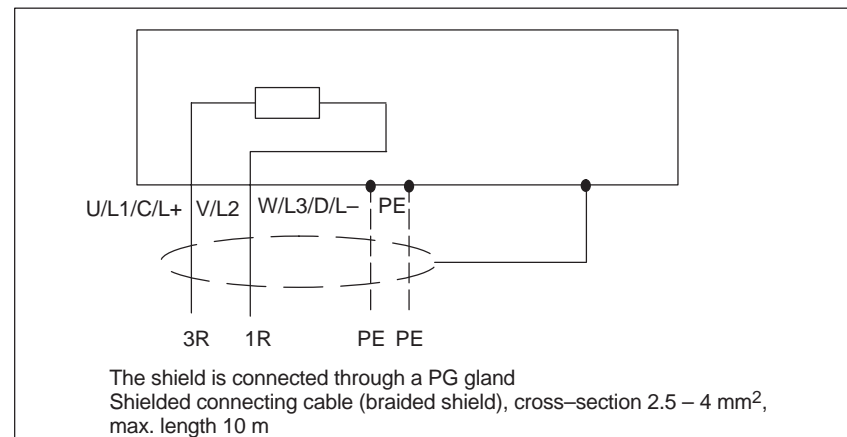

Fig. 6-24 Connection for external PR for braking power ratings up to 1.5/25 kW

### Note

Conductors that are not used in multi-conductor cables must always be connected to PE at both ends.

6.7 DC link options

28 kW UI module

The UI 28 kW module requires external pulsed resistors. Up to two identical resistors – with the same power rating – can be connected.

Connecting external pulsed resistors to the 28 kW module

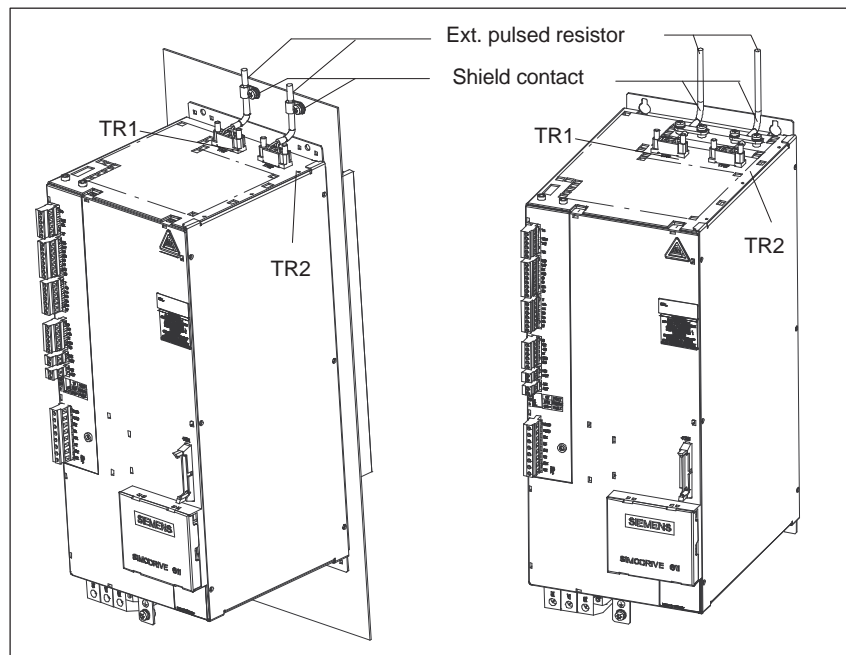

Fig. 6-25 Connecting the external pulsed resistor with shield connection

Table 6-25 Permissible ways of connecting external pulsed resistors to a 28 kW UI

PR	Terminal block TR1	Terminal block TR2
0.3/25 kW	1R 2R 3R 	1R 2R 3R 
2 x 0.3/25 kW=0.6/50 kW	1R 2R 3R 	1R 2R 3R 
1.5/25 kW	1R 2R 3R 	1R 2R 3R 
2 x 1.5/25 kW=3/50 kW	1R 2R 3R 	1R 2R 3R 

1) Jumper for coding the thermal limit characteristic

**Note**

An external resistor cannot be connected to a 5 kW or 10 kW UI.

### 6.7.4 Engineering information is applicable for UI 5 kW, 10 kW, 28 kW and PR module

#### Sizing the load duty cycles with pulsed resistors

$E$ [Ws]	Regenerative feedback energy when braking a motor from $n_2$ to $n_1$
$T$ [s]	Period of the braking load duty cycle
$A$ [s]	Load duration
$J$ [kgm <sup>2</sup> ]	Total moment of inertia (including $J$ motor)
$M$ [Nm]	Braking torque
$n$ [RPM]	Speed
$P_n$ [W]	Continuous power rating of the pulsed resistor
$P_{max}$ [W]	Peak power of the pulsed resistor
$E_{max}$ [Ws]	Energy of the pulsed resistor for a single braking operation

#### Load duty cycles for braking operations

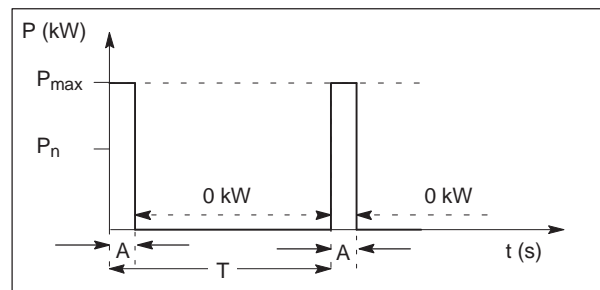

Fig. 6-26 Load duty cycle for internal and external pulsed resistors

Table 6-26 Examples

	Values	PR 0.2/10 kW	PR 0.3/25 kW	PR 1.5/25 kW
	$E_{max}$	13500 Ws <sup>1)</sup>	7500 Ws	180000Ws
	$P_n$	200 W	300 W	1500 W
	$P_{max}$	10000 W	25000 W	25000 W
Example	$A =$	0.2 s	0.12 s	0.6 s
	$T =$	10 s	10 s	10 s
	$A =$	1.35 s	0.3 s	7.2 s
	$T =$	67.5 s	25 s	120 s

1) As a result of the mechanical dimensions, the resistor can absorb a relatively high level of energy.

The following conditions must be fulfilled:

- $P_{max} \geq M \cdot 2 \cdot \pi \cdot n / 60$
- $E_{max} \geq E; E = J \cdot [(2 \cdot \pi \cdot n_2 / 60)^2 - (2 \cdot \pi \cdot n_1 / 60)^2] / 2$
- $P_n \geq E / T$





## Line Supply Connection

### 7.1 Line supply connection conditions for line supply infeed

#### Supply voltage and frequency

For technical data, refer to Chapter 6.4 and Tables 7-1/7-2.

#### Compatibility/noise immunity

SIMODRIVE infeed units are designed to be connected to line supplies with compatibility level, Class 3 of electromagnetic environments in industrial plants and systems according to IEC/DIN EN61000-2-4:2002.

When the EMC mounting/installation guidelines are complied with, noise immunity values according to IEC/DIN EN61000-6-2 Electromagnetic Compatibility (EMC) – Generic Standard, Noise Immunity/emission – Part 2: Industrial environments (1999) are complied with.

#### Direct connection to line supplies with selective AC/DC-sensitive RCCBs

The SIMODRIVE unit may be directly connected to TN line supplies with selectively tripping, AC/DC-sensitive RCCBs as protective measure.

Upstream devices providing protection against hazardous leakage currents or for fire protection (such as residual-current protective devices) must be universal current-sensitive in accordance with the requirements of DIN EN 50178. In the case of other residual-current protective devices, a transformer with separate windings must be connected upstream of the converter for purposes of decoupling.

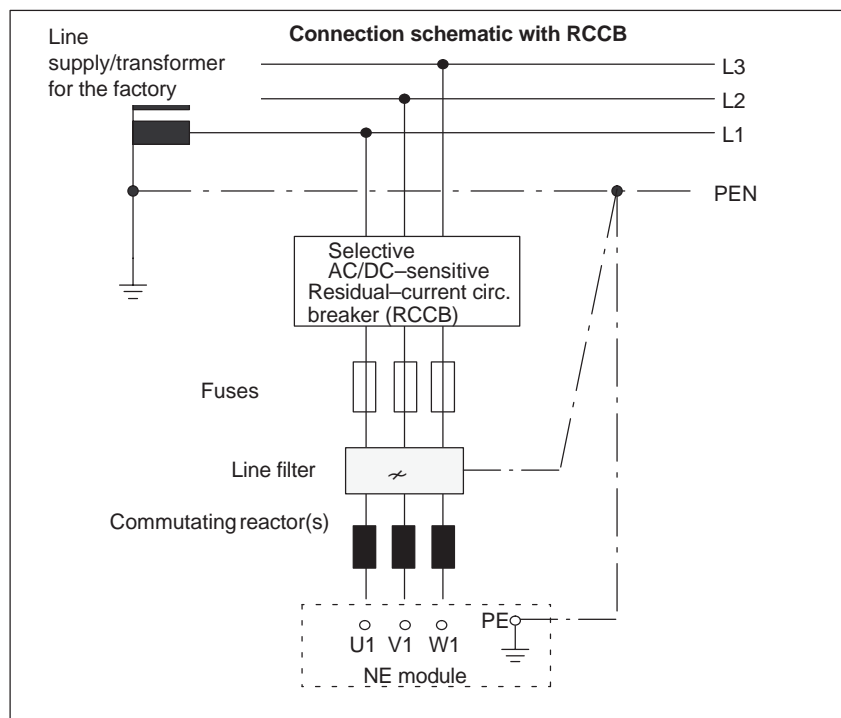

Fig. 7-1 Residual-current circuit-breaker (RCCB) connection schematic



---

### 7.1 Line supply connection conditions for line supply infeed

---

---

#### Note

If a **fault current protective device** is used on the line supply side of this electronic device for protection in case of direct or indirect contact, only **Type B** is permitted! Otherwise, another protection measure must be applied, such as separating the electronic device from the environment through double/reinforced insulation or separating the electronic device from the line supply through a transformer.

---

---

#### Note

Points to bear in mind:

- It is only permissible to use a delayed-tripping, (selective) AC/DC current-sensitive residual-current protective device (RCCB) (connection as shown in Fig. 7-1).
  - Parts of the electrical equipment and machine that can be touched are integrated in a protective grounding system.
  - It is not possible to connect RCCBs in series in order to implement selective tripping.
  - The max. permissible ground resistance of the "selective protection device" must be observed ( $83 \Omega$  max. for RCCBs with a rated differential current  $I_{\Delta n} = 0.3 \text{ A}$ ).
  - The total length of the shielded power cables used in the drive group (motor cable, incl. supply cables from supply system filters to the NE connection terminals) is less than 350/500 m for sinusoidal/squarewave current.
  - Operation is only permitted with line filters. Only the line filters described in Chapter 7 may be used.
- 

---

#### Notice

The currently widely established AC or pulse-current sensitive **Type A** are definitely not suitable!

---

#### Recommendation

For selective, AC/DC-sensitive residual-current protective devices offered by Siemens that comply with DIN VDE 0100 T480 and EN 50178, i.e. Series 5SM3 646-4 short-time delayed or Series 5SM3 646-5 selective with auxiliary disconnector (1 NC/1 NO) for rated current of 63 A, rated fault current  $I_{\Delta n} = 0.3 \text{ A}$ , see Catalog "BETA Modular Installation Devices-ETB1")

## 7.1 Line supply connection conditions for line supply infeed

**Harmonics fed back into the line supply/noise emission**

When the requirements regarding system fault level are observed and when using the appropriate line supply filters, the harmonics fed back into the line supply lie below the compatibility level of Class 3 of the electromagnetic environment of industrial plants and systems according to EN61000–2–4:2002.

When the recommended SIEMENS line filter is used and the EMC mounting/installation regulations are complied with, the noise emission limits according to EN50081–2 Electromagnetic Compatibility (EMC) – Generic Standard, Noise Immunity/emission – Part 2: Industrial environments (1993) are complied with.

**Notice**

If line filters are used that SIEMENS has not certified for use with SIMODRIVE 6SN11xx/6SLxx, this can result in harmonics being fed back into the line supply. These harmonics can damage/disturb other equipment connected to this line supply. Certification, e.g. CE is invalid.

Certificates from Siemens are invalid, for example CE, UL. You are responsible for generating/obtaining the certificates for this new combination.

It is not permissible to connect additional loads after the line filter

Table 7-1 Line supply connection conditions for NE modules

Module	Description		
	<p>The NE modules are designed for symmetrical 3-phase line supplies with grounded neutral point: TN systems. No further consumers with asymmetric load (single-phase) may be connected for transformers with non-loadable neutral point. The line supply specifications according to EN 50178 are complied with as a result of the series (upstream) line reactor (for 5 kW and 10 kW UI, these are integrated in the module).</p> <p><b>Notice</b></p> <p>The described minimum line supply fault level is needed to trigger the fuses in the case of ground fault and short-circuit within the prescribed time in order to protect the plant and prevent damage and faults at other devices. An insufficient system fault level (short-circuit power) increases the triggering and also prevents the triggering of the fuses. This can cause, for example, arcs with the consequent fire of danger.</p> <p>The following applies for several converters connected to one line supply:</p> <p>The <math>S_K</math> of the line supply must as a minimum, be sufficient for the highest rating converter connected to it. When selecting and dimensioning the protective elements, Chapter 7.3 must be carefully observed!</p> <p>The required apparent power of the line supply for each NE module is <math>S_n = P_n \cdot 1.27</math>. When operating one infeed alone on a matching transformer, as a minimum, an <math>S_K</math> of 0.73 times the value from the table is permissible.</p>		
<b>UI modules</b>	Operation on line supplies from $S_{Kline}/P_n \geq 30$		
<b>I/R module</b>	<b>Pn I/R module</b>	<b>Sinusoidal current operation (S1.6 = ON)</b>	<b>Squarewave current operation (S1.6 = OFF)</b>
	16 kW	$S_K \text{ line} \geq 1.0 \text{ MVA}$ ( $70 \cdot P_{nI/R \text{ module in kW}}$ )	$S_K \text{ line} \geq 1.5 \text{ MVA}$ ( $100 \cdot P_{nI/R \text{ module in kW}}$ )
	36 kW	$S_K \text{ line} \geq 2.5 \text{ MVA}$ ( $70 \cdot P_{nI/R \text{ module in kW}}$ )	$S_K \text{ line} \geq 3.5 \text{ MVA}$ ( $100 \cdot P_{nI/R \text{ module in kW}}$ )
	55 kW	$S_K \text{ line} \geq 4.0 \text{ MVA}$ ( $70 \cdot P_{nI/R \text{ module in kW}}$ )	$S_K \text{ line} \geq 5.5 \text{ MVA}$ ( $100 \cdot P_{nI/R \text{ module in kW}}$ )
	80 kW	$S_K \text{ line} \geq 5.0 \text{ MVA}$ ( $60 \cdot P_{nI/R \text{ module in kW}}$ )	$S_K \text{ line} \geq 6.5 \text{ MVA}$ ( $80 \cdot P_{nI/R \text{ module in kW}}$ )
	120 kW	$S_K \text{ line} \geq 7.0 \text{ MVA}$ ( $60 \cdot P_{nI/R \text{ module in kW}}$ )	$S_K \text{ line} \geq 9.5 \text{ MVA}$ ( $80 \cdot P_{nI/R \text{ module in kW}}$ )

## 7.1 Line supply connection conditions for line supply infeed

Table 7-2 Engineering information, if you dimension and select the transformer yourself

Used I/R module $P_r/P^A$	Required rated power $S_n$ of the isolating/autotransformer	Required uk short-circuit voltage
16/21 kW	$S_n \geq 21 \text{ kVA}$	$uk \leq 3\%$
36/47 kW	$S_n \geq 46 \text{ kVA}$	$uk \leq 3\%$
55/71 kW	$S_n \geq 70 \text{ kVA}$	$uk \leq 3\%$
80/120 kW	$S_n \geq 102 \text{ kVA}$	$uk \leq 3\%$
120/156 kW	$S_n \geq 153 \text{ kVA}$	$uk \leq 3\%$
UI module used $P_r/P^A$	Required rated power $S_n$ of the isolating/autotransformer	Required uk short-circuit voltage
5/10 kW	$S_n \geq 6.4 \text{ kVA}$	$uk \leq 10\%$
10/25 kW	$S_n \geq 13 \text{ kVA}$	$uk \leq 10\%$
28/50 kW	$S_n \geq 36 \text{ kVA}$	$uk \leq 10\%$

**No ground faults**

Before powering-up the system for the first time, the cabinet wiring, the motor/encoder feeder cables and DC link connections must be carefully checked to ensure that there are no ground faults.

## Overvoltage limiter module

### Application

The overvoltage limiter module limits overvoltages at the line supply input to acceptable values. These overvoltages can occur, e.g. due to switching operations at inductive loads and line supply matching transformers.

The overvoltage limiting module is used for upstream transformers or for line supplies that are not in conformance with IEC (unstable line supplies) or in line supplies where frequently switching operations occur, e.g. involving larger motors (from approx. 30 kW). The overvoltage limiting module is mandatory if the NE module is to be used in conformance with UL.

For NE modules from 10 kW and higher (100 mm wide), the overvoltage limiting module can be inserted at interface X181.

For the 5 kW overvoltage limiting module, an appropriate protective circuit is already integrated as standard.

### Note

It is absolutely necessary to use the overvoltage limiting module:

- For line supplies in which higher power loads are directly connected (depending on the line supply stiffness and extent of the line supply, already necessary from 20 kW and above), and if
- Line supplies, that do not reliably fulfill the line supply specifications according to IEC-/EN 61000-2-4.

Table 7-3 Technical specifications

Max. energy absorption	100 Joule
Weight	approx. 0.3 kg
Dimensions (H x W x D)	76 mm x 70 mm x 32.5 mm
Power module depth with overvoltage limiter module	325 mm
Order number	6SN11 11-0AB00-0AA0

### Rated conditions

The following operating conditions apply:

- A voltage limiter must be used when transformers are used in front of the NE module.
- This limits the voltage for overvoltage condition caused by switching operations, when the line supply frequently fails, for arcing etc.
- Plants and systems that are to fulfill UL/CSA requirements must be equipped with overvoltage limiter modules.
- To protect the devices against line-side overvoltages, it is recommended that an overvoltage protection device is used directly at the supply point, in front of the main switch. In order to comply with the requirements of CSA C22.2 No. 14-05, an overvoltage protection device is absolutely mandatory. For suitable surge arresters, refer to [www.raycap.com](http://www.raycap.com) for example [www.raycap.com](http://www.raycap.com).

## 7.1 Line supply connection conditions for line supply infeed

**Assembly**

1. Disconnect the equipment from the power source and ensure that it is in a no-voltage condition.
2. Withdraw connector X181 from the NE module.
3. Insert the overvoltage limiter module into connector X181 up to its endstop.
4. Insert connector X181 onto the overvoltage limiter module.

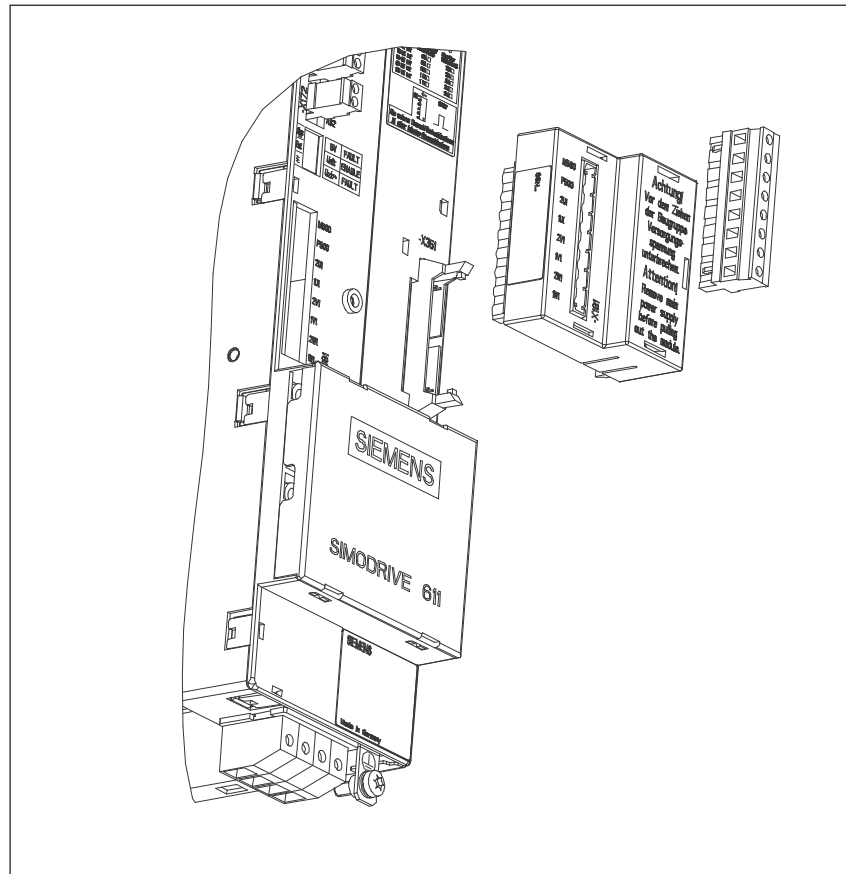

Fig. 7-2 Overvoltage limiter module

**Notice**

If the system is subject to a high-voltage test, then the overvoltage limiting module must be withdrawn in order to prevent the voltage limiting function from responding

## 7.2 Voltage matching

### 7.2.1 General

A distinction is made between:

- Line connection components to be directly connected to the line supply
- Line connection components to be directly connected to an autotransformer
- Line connection components to be directly connected to an isolating transformer

---

#### Note

If isolating transformers are used upstream (in front of) I/R and UI modules, an overvoltage limiter module (Order No.: 6SN1111-0AB00-0AA0) must be used, refer to Chapter 6.7.2.

For 5 kW UI module (Order No.: 6SN1146-2AB00-0BA1), a voltage limiter circuit is included.

---

### 7.2.2 Line supply types

The air and creepage distances in the SIMODRIVE 611 drive converter system have been dimensioned for rated voltages up to 520 V AC, 300 V phase-grounded neutral point.

This voltage may never be exceeded as otherwise the converter insulation system would be damaged and would result in inadmissibly high touch voltages.



---

#### Caution

The drive converters may only be connected to TN line supplies, either directly or through an autotransformer.

The SIMODRIVE 611 drive converter system is insulated in compliance with DIN EN 61800-5-x. This means that the insulation system is designed for direct connection to a TN line supply with grounded neutral point. For all other line supply types, an isolating transformer with neutral point on the secondary side must be used upstream (in front of) the units. This transformer is used to de-couple the line supply circuit (overvoltage Category III) from a non line-supply circuit (overvoltage Category II), refer to IEC 60644-1.

---

## 7.2 Voltage matching

**Connection types** The infeed can be directly connected to a TN line supply for 3-ph. 400 V AC, 3-ph. 415 V AC, 3-ph. 480 V AC

For other voltage levels, the infeed can be connected through an autotransformer.

**Example:**  
**TN-C line supply**

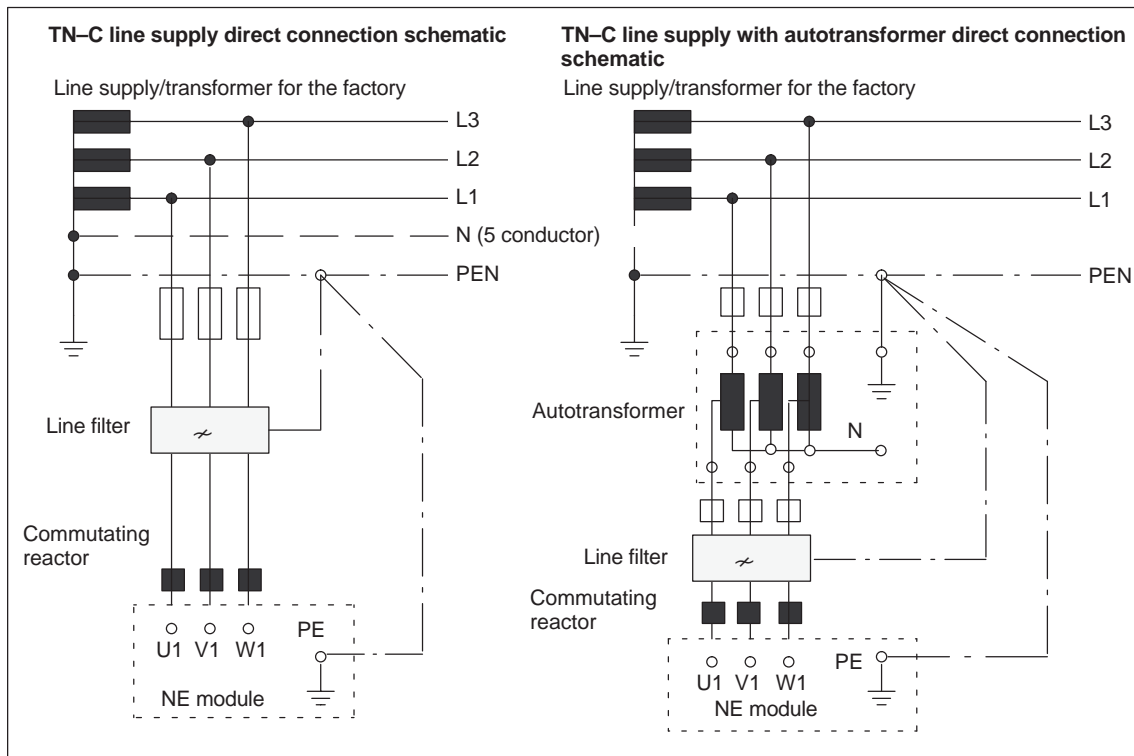

Fig. 7-3 TN-C line supply connection schematic

**TN-C line supply**  
**TN-S line supply**  
**TN-C-S line supply**

Symmetrical 4-conductor or 5-conductor three-phase line supply with grounded neutral point with a protective and neutral conductor connector connected at the neutral point which, depending on the line supply type, uses one or several conductors.

**For other line supply types <sup>1)</sup> the NE module must be connected through an isolating transformer.**

<sup>1)</sup> Harmonized transformer types are described in Siemens Catalog NC 60.

**TT line supply**

Symmetrical 3-conductor or 4-conductor three-phase line supply with a directly grounded point. The loads are grounded, e.g. with grounds that are not electrically connected to the directly grounded point of the line supply.

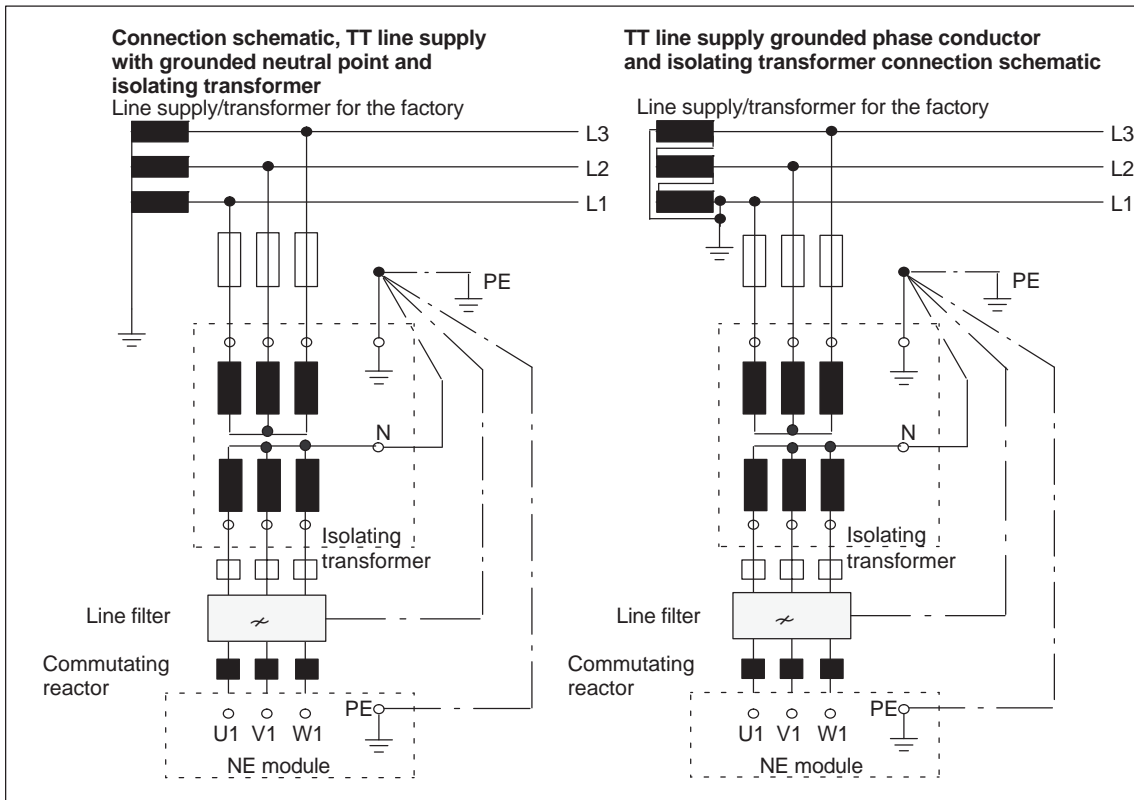

Fig. 7-4 TT line supplies connection schematic



## 7.2 Voltage matching

**IT line supply**

Symmetrical 3-conductor or 4-conductor three-phase line supply with no directly grounded point. The loads are connected, e.g. with grounds.

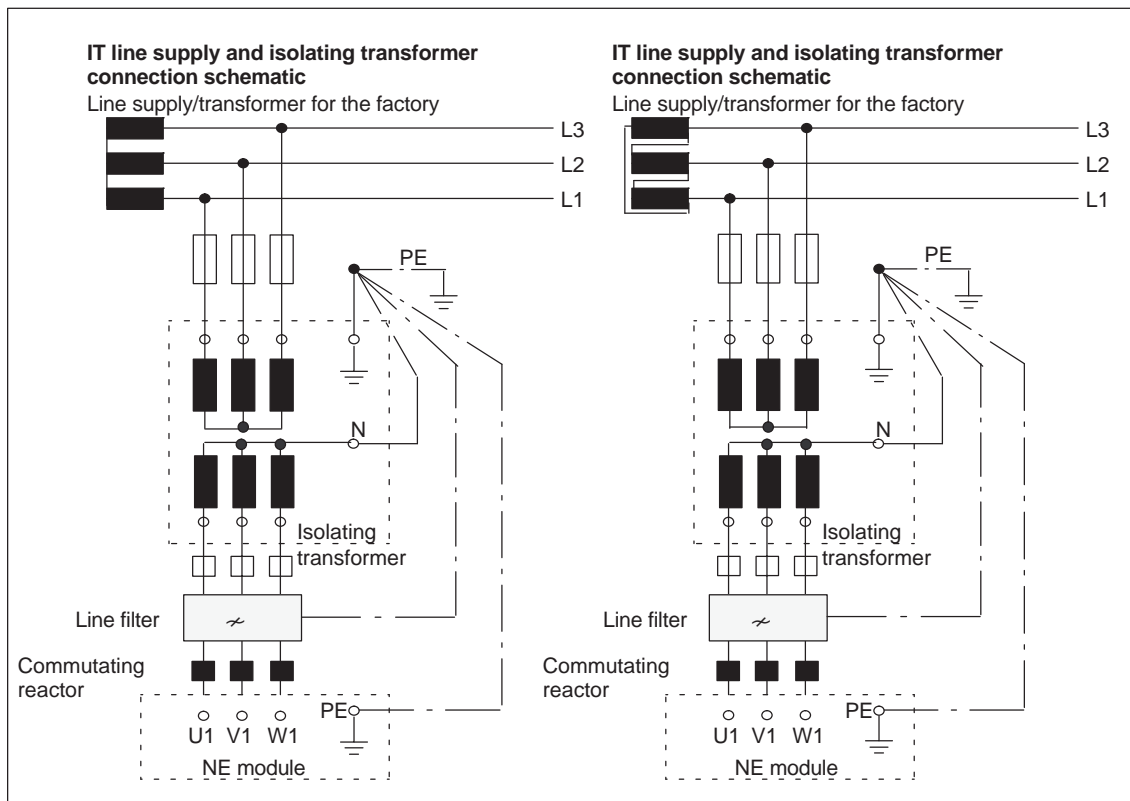

Fig. 7-5 IT line supplies connection schematic

Thus, within the pulsed transistor converter, the voltage stressing on the insulating clearances between the power circuits at the line supply potential and the open and closed-loop control circuits referred to the protective conductor potential, according to a rated voltage of 300 V complies with IEC/DIN EN 50178.

Due to the 6-pulse 3-phase bridge circuit in the line supply infeed module, any fault currents will contain DC components. This must be taken into consideration when selecting/dimensioning a fault current protective device, e.g. an RCCB.

### 7.2.3 Minimum cross-sections for PE (protective conductor)/equipotential bonding conductor

Table 7-4 Minimum cross-sections for PE (protective conductor)

$P_{\text{rated}}$ [kW]	$I_{\text{rated}}$ [A]	PE [mm <sup>2</sup> ]	PE [AWG/kcmil]
5	7	1.5	16
10	14	4	14
28	40	10	8
16	23	4/10	10
36	52	16	6
55	79	16	4
80	115	25	3
120	173	50	1/0

### 7.2.4 Transformers

For the assignment of transformers (auto/isolating transformers) with supply voltages of 3-ph. 220 V AC to 3-ph. 575 V AC to the NE modules, refer to Sections 7.3.2 to 7.3.4.

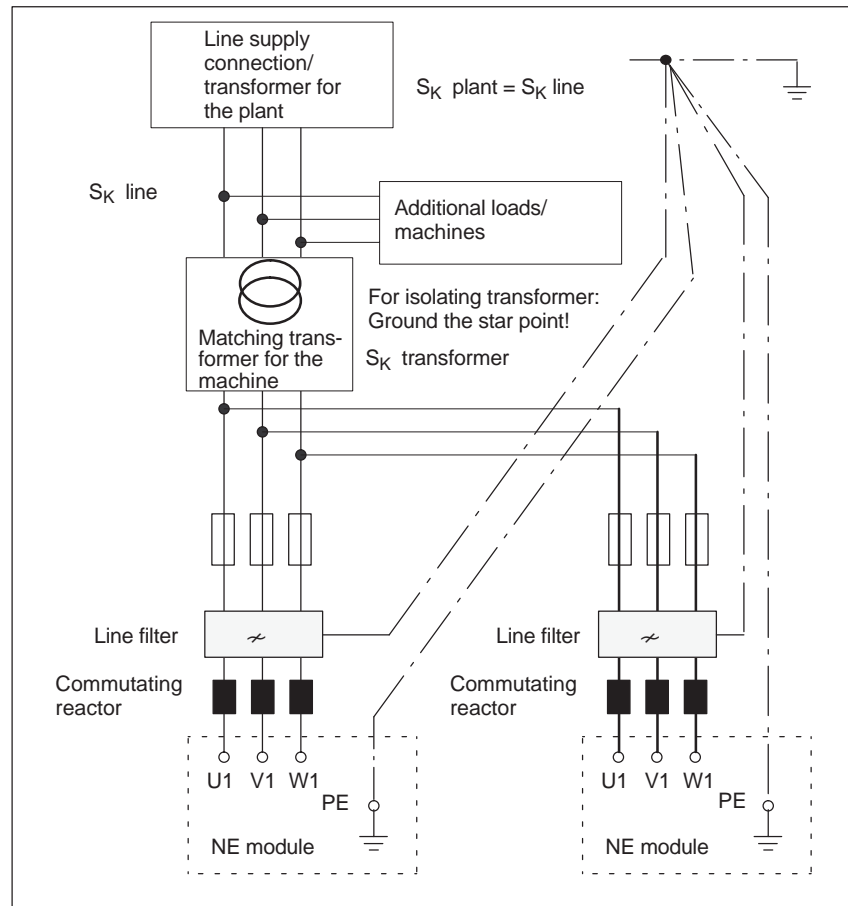

Fig. 7-6 Connection schematic, matching transformer

#### Vector group

Suggestion: Dyn0 or Yyn0; this means either a delta or star circuit on the primary side and star circuit on the secondary side where the neutral point is brought-out. For the connection, refer to Section 7.2.2.

#### Note

Switching elements (main switch, contactors) for connecting and disconnecting the line filter must feature a max. 35 ms delay time between closing and opening individual main contacts.

### Matching transformer configuration

A SIMODRIVE NE module and other loads/machines are connected at the matching transformer (refer to Fig. 7-7).

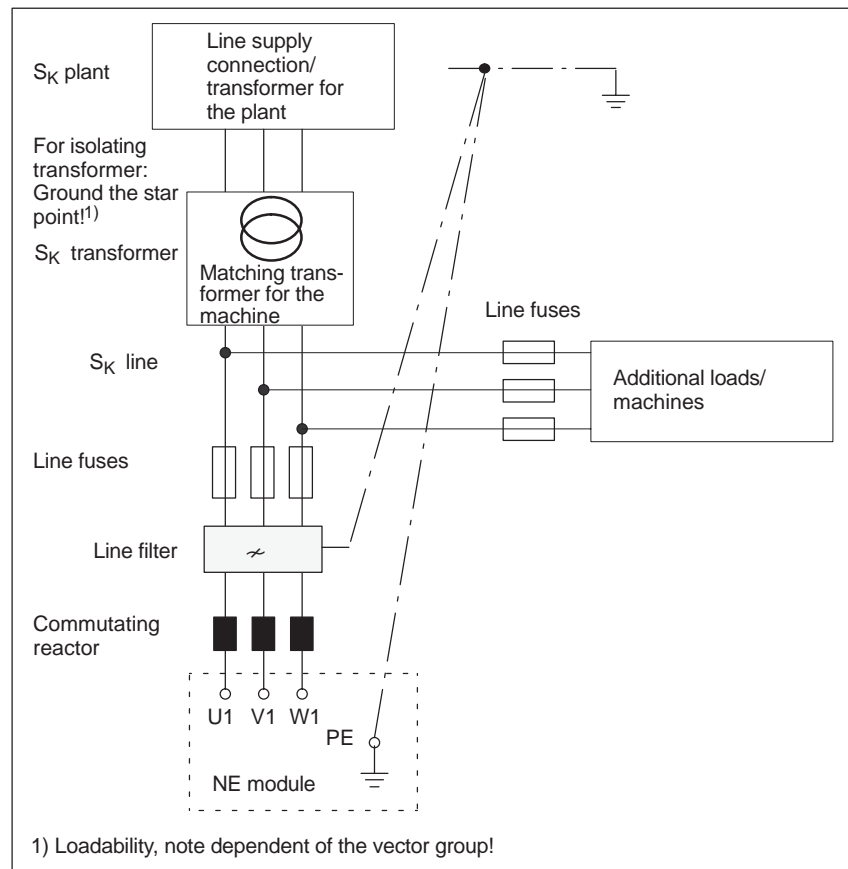

Fig. 7-7 Connection schematic, matching transformer for additional loads

A matching transformer must be dimensioned for the total of all loads connected to it. The apparent power required for the NE modules must be determined and added as shown in Chapter C.1.3, Table 7-1. If the transformer  $S_n$  or  $S_K$  is too small, this can lead to increased line voltage dips and faults in the system and in other loads at this connecting point.

The short-circuit power must be adequately dimensioned so that the overcurrent protective device reliably trips.



#### Warning

A sufficiently high system fault level (short-circuit power) is required to ensure that when a ground fault does occur, the fuses rupture in the specified time. An insufficient system fault level (short-circuit power) increases the time to trip beyond permissible levels (e.g. a fire is possible).

## 7.2 Voltage matching

**S<sub>n</sub> calculation of the matching transformer for an NE module**

- Condition a)

The rated power (S<sub>n</sub>) of the matching transformer must be:

$$S_{n1} \geq 1.27 \cdot P_n \text{ (I/R module [kW])} \quad [\text{kVA}]$$

Example: The minimum rated power of a matching transformer for I/R module 16/21 is 21 kVA.

- Condition b)

In order to avoid faults and disturbances at the other loads, that are connected to the secondary side of the matching transformer, the sum of the system fault level (short-circuit power) of the plant connection and that of the matching transformer at the connection point (S<sub>K line supply</sub>) must contain at least the values shown in Table 7-1, Chapter C.1.3. Depending on the vector group of the transformers, e.g. YYn0, asymmetric loading of the N/MP may not be permitted.

Consequently, the required rated power S<sub>n2</sub> of the matching transformer is calculated.

$$S_{n2} = \frac{S_{K \text{ plant}} \cdot S_{K \text{ line}} \cdot uk}{(S_{K \text{ plant}} - S_{K \text{ line}}) \cdot 100} \quad [\text{kVA}]$$

This means:

S<sub>n1</sub>, S<sub>n2</sub> Calculated rated power of the matching transformer

uk Short-circuit voltage of the matching transformer as % (see Table 7-2)

S<sub>K</sub> Short-circuit power.

S<sub>K plant</sub> if necessary, consult the utility company

S<sub>K line</sub> = at least the value contained in Chapter C.1.3, Table 7-1

**Note:**

The system fault level at the plant connection S<sub>K plant</sub> plays a decisive role in dimensioning/selecting the matching transformer.

From the rated power (S<sub>n1</sub> or S<sub>n2</sub>) calculated under a) and b), the higher must be used for the matching transformer.

**Examples**

Matching transformer for 16/21 kW I/R module sinusoidal current:

uk matching transformer = 3%; S<sub>K plant</sub> = 50000 kVA ; S<sub>K line</sub> for I/R 16/21 kW sinusoidal current according to Table 7-1: S<sub>K line</sub> = 1120 • 0.73 = 820 kVA

based on a) S<sub>n1</sub> = 1.27 • 16 kW = 21 kVA

based on b) Calculation of S<sub>n2</sub>

**Case 1:**

$$S_{n2} = \frac{50000 \cdot 820 \cdot 3}{(50000 - 820) \cdot 100} = 25 \text{ kVA}$$

$$S_{n2} > S_{n1} \Rightarrow S_{n2} \text{ is decisive}$$

The matching transformer requires a rated power S<sub>n</sub> of 25 kVA at a uk of 3%.

**Case 2:**

If the uk of the matching transformer is less than, e.g. uk=1% for otherwise unchanged conditions for Case 1:

$$S_{n2} = \frac{50000 \cdot 820 \cdot 1}{(50000 - 820) \cdot 100} = 8.3 \text{ kVA}$$

$$S_{n1} > S_{n2} \Rightarrow S_{n1} \text{ is decisive}$$

The matching transformer requires an S<sub>n</sub> rated power of 21 kVA at a uk of 1%.

**Case 3:**

If  $S_{K \text{ plant}}$  is less, then a transformer with a higher rating must be selected, e.g.  $S_{K \text{ plant}} = 3000 \text{ kVA}$ ; otherwise as for Case 1:

$$S_{n2} = \frac{3000 \cdot 820 \cdot 3}{(3000 - 820) \cdot 100} = 34 \text{ kVA}$$

$S_{n2} > S_{n1}$  %  $S_{n2}$  is decisive

The matching transformer requires a rated power  $S_n$  of 34 kVA at a uk of 3%.

**Case 4:**

When compared to Case 3, the uk of the matching transformer is reduced to, e.g. uk = 1%:

$$S_{n2} = \frac{3000 \cdot 820 \cdot 1}{(3000 - 820) \cdot 100} = 11.3 \text{ kVA}$$

$S_{n1} > S_{n2} \Rightarrow S_{n1}$  is decisive

The matching transformer requires a rated power  $S_n$  of 21 kVA at a uk of 1%.

**Note**

$S_{n2}$  for the matching transformer can be reduced by reducing uk.

### **$S_n$ calculation of the matching transformer for several loads**

- Condition a)

The rated power ( $S_n$ ) of the matching transformer must always be:

$$S_{n1} \geq 1.27 \cdot P_n (\text{I/R module [kW]}) \quad [\text{kVA}]$$

- Condition b)

In order to avoid faults and disturbances at the other loads, that are connected to the secondary side of the matching transformer, the sum of the system fault level (short-circuit power) of the plant connection and that of the matching transformer at the connection point ( $S_{K \text{ line}}$  supply) must contain at least the values shown in Table 7-1, Chapter C.1.3. Depending on the vector group of the transformers, e.g. Yyn0, asymmetric loading of the N/MP may not be permitted.

Consequently, the required rated power  $S_{n2}$  of the matching transformer is calculated.

$$S_{n2} = \frac{S_{K \text{ plant}} \cdot S_{K \text{ line}} \cdot uk}{(S_{K \text{ plant}} - S_{K \text{ line}}) \cdot 100} \quad [\text{kVA}]$$

**Note:**

The system fault level at the plant connection  $S_{K \text{ plant}}$  plays a decisive role in dimensioning/selecting the matching transformer.

From the rated power ( $S_{n1}$  or  $S_{n2}$ ) calculated under a) and b), the higher must be used for the matching transformer.

## 7.2 Voltage matching

**Examples**

Matching transformer for 36/47 kW I/R module sinusoidal current:  
 uk matching transformer = 3%;  $S_{K \text{ plant}} = 50000 \text{ kVA}$ ;  $S_{K \text{ line}}$  for I/R 36/47 kW  
 sinusoidal current according to Table 7-1:  $S_{K \text{ line}} = 2520 \text{ kVA}$

based on a)  $S_{n1} = 1.27 \cdot 36 \text{ kW} = 45.72 \approx 46 \text{ kVA}$

based on b) Calculation of  $S_{n2}$

**Case 1:**

$$S_{n2} = \frac{50000 \cdot 2520 \cdot 3}{(50000 - 2520) \cdot 100} = 79.61 \approx 80 \text{ kVA}$$

$S_{n2} > S_{n1} \Rightarrow S_{n2}$  is decisive

The matching transformer requires a rated power  $S_n$  of 80 kVA at a uk of 3%.

**Case 2:**

If the uk of the matching transformer is less than, e.g. uk=1% for otherwise unchanged conditions for Case 1:

$$S_{n2} = \frac{50000 \cdot 2520 \cdot 1}{(50000 - 2520) \cdot 100} = 26.54 \approx 27 \text{ kVA}$$

$S_{n1} > S_{n2} \Rightarrow S_{n1}$  is decisive

The matching transformer requires an  $S_n$  rated power of 46 kVA at a uk of 1%.

## 7.3 Overcurrent protective devices, transformers and main switch

### 7.3.1 Assignment of the line fuses to the NE modules

Fuses or circuit breakers are necessary to protect the cables against short-circuit/ground fault, to limit any damage to the converter, provide protection against electric shock and to avoid fire in the case of a fault. The overvoltage protective devices must be located before the terminals of the drive lineup (line filter or HFD reactor)!



#### Danger

Overvoltage protective devices only on the primary side of a transformer, which may be possibly used, are not sufficient to protect the converter or protect against fire!

Fuses and plant conditions, such as loop resistance and short-circuit power, must be harmonized with each other so that the limit curve shown in Fig. 7-8 is not exceeded.

Circuit breakers (Table 7-6) or alternatively, fuses (Table 7-7) should be used.

The appropriate protection measure should be selected corresponding to the local situation from Table 7-5.

Table 7-5 Selection aid for line supply protection measures

Short-circuit power as specified in the Configuration Manual	Loop resistance allows short-circuit current	Transformer vector group can be loaded asymmetrically	Protection	Risk
✓	✓	✓	Fusible links in accordance with the documentation when tripped in less than 10 ms (1) or (2), (3), (4), (5)	Minimum residual risks
✓	–	✓	Circuit-breaker with parameterized magnetic short-circuit deactivation adapted to the loop resistance (2), (3), (4), (5)	Minimum residual risks
✓	–	–	RCD switch (AC/DC-sensitive type B) and isolating transformer or circuit-breaker with residual current monitor (RCM) (4), (5)	Incorrect trips for large converter configurations with a high rated power
–	✓	✓	Fusible links in accordance with the documentation that can be tripped in less than 10 ms (1) in accordance with test, (2), (3), (4), (5)	Excessively high line dips for other loads
–	–	–	RCD switch (AC/DC-sensitive type B) and isolating transformer or circuit-breaker with residual current monitor (RCM) (4), (5)	Excessively high line dips for other loads

- 1) Assignment of the possible circuit breakers to the NE modules, see Table 7-6  
Assignment of fuses to the NE modules, see Table 7-7



## 7.3 Overcurrent protective devices, transformers and main switch

Table 7-6 Assignment of the possible circuit breakers to the NE modules

	UI module 5/10 kW	UI module 10/25 kW	UI module 28/50 kW	I/R module 16/21 kW	I/R module 36/47 kW	I/R module 55/71 kW	I/R module 80/104 kW	I/R module 120/156 kW
Circuit breakers [2], <sup>1)</sup>	3VL1702– 2DD3□–....	3VL1703 –2DD3□– ....	3VL1708– 2DD3□–....  3VL2708– 2DC3□–....  3VL2708– 3DC3□–....	3VL1703– 2DD3□–...  .	3VL1708– 2DD3□–....  3VL2708– 2DC3□–....  3VL2708– 3DC3□–....	3VL2712– 2DC3□–....  3VL2712– 3DC3□–....	3VL2716– 2DC3□–....  3VL2716– 3DC3□–....	3VL3725– 2DC3□–....  3VL3725– 3DC3□–....
Minimum short- circuit current <sup>2)</sup>	300 A	300 A	1000 A	300A	1000 A	1500 A	2000 A	3000 A
Circuit breakers UL appro- vals <sup>3)</sup> [3] <sup>1)</sup>	3VL1102– 2KM30–....	3VL1103 –2KM30– ....	3VL2108– 2KN30–....	3VL2105– 2KN30–....  3VL1135– 2KM30–...  .	3VL2108– 2KN30–....	3VL2112– 2KN30–....	3VL3117– 2KN30–....	3VL3125– 2KN30–....
Minimum short- circuit current <sup>2)</sup>	450 A	450 A	1000 A	840 A  900 A	1000 A	1500 A	2400 A	3000 A
Residual current monitor including UL <sup>4)</sup> [5] <sup>1)</sup>	FI-Breakers 5SM3–... + fuse				RCMA470LY–21 AC/DC30 mA–3 A Transducer: W1–A35S internal diameter 35 mm or Transducer: W2–A70SS internal diameter 70 mm			

1) Selection aid for line supply protection measures, see Table 7-5

2) **Minimum short-circuit current:** Before connecting the machine to the line supply, the necessary minimum value must be checked using a measurement corresponding to IEC 61557–3 and documented. If the minimum short-circuit currents at the connection point are not reached, then there is a risk of fire in the case of a fault.

3) The switches are designed for high switching capacity 65 kA at 480 V.  
The connection terminals for the switches are also required.  
The following box terminals, for example, are required:  
**for 3VL2...: two 3VL9220–4TC31 sets (one set contains three items)**  
**for 3VL3...: two 3VL9335–4TC31 sets (one set contains three items)**  
You can find information on circuit breakers under the following link:  
<http://support.automation.siemens.com>  
There, enter "SIRIUS Configuration Manual" as search term.

4) In combination with the appropriate circuit-breakers.

## 7.3 Overcurrent protective devices, transformers and main switch

Fuses that can be used: Sizes NH, D, DO with characteristic gL.  
We recommend the following SIEMENS fuses that have no restrictions relating to the characteristic power data of the NE modules.

Table 7-7 Assignment of fusible links to the NE modules

	UI module 5/10 kW	UI module 10/25 kW	UI module 28/50 kW	I/R module 16/21 kW	I/R module 36/47 kW	I/R module 55/71 kW	I/R module 80/104 kW	I/R module 120/156 kW
Rated voltage 400 V~ [1] <sup>1)</sup>	16 A D01 Neoz./ Order No. 5SE2316	25 A D02 Neoz./ Order No. 5SE2325	–	35 A D02 Neoz./ Order No. 5SE2325	–	–	–	–
Rated voltage 500 V~ [1] <sup>1)</sup>	16 A DII Diazed/ Order No. 5SB261	25 A DII Diazed/ Order No. 5SB261	80 A DIV Diazed/ Order No. 5SC211	35 A DIII Diazed/ Order No. 5SB411	80 A DIV Diazed/ Order No. 5SC211	–	–	–
Rated voltage 500 V~ [1] <sup>1)</sup>	16 A Size 00 LV HRC/ Order No. 3NA3805	25 A Size 00 LV HRC/ Order No. 3NA3810	80 A Size 00 LV HRC/ Order No. 3NA3824	35 A Size 00 LV HRC/ Order No. 3NA3814	80 A Size 00 LV HRC/ Order No. 3NA3824	125 A Size 00 LV HRC/ Order No. 3NA3832	160 A Size 1 LV HRC/ Order No. 3NA3136	250 A Size 1 LV HRC/ Order No. 3NA3144
Minimum short- circuit current <sup>2)</sup>	270 A	500 A	1600 A	700 A	1600 A	2800 A	3400 A	5800 A
Fuses for North America								
Designa- tion [1] <sup>1)</sup>	AJT 17.5	AJT 25	AJT 80	AJT 35	AJT 80	AJT 125	AJT 175	AJT 250
Minimum short- circuit current <sup>2)</sup>	270 A	380 A	1100 A	600 A	1100 A	1800 A	2500 A	3100 A

- 1) Tool to select the overcurrent protective devices, see Table 7-5
- 2) Minimum short-circuit current: Before connecting the machine to the line supply, the necessary minimum value must be checked using a measurement corresponding to IEC 61557-3 and documented. If the minimum short-circuit currents at the connection point are not reached, then there is a risk of fire in the case of a fault.

---

### 7.3 Overcurrent protective devices, transformers and main switch

---

**Notice**

The calculated maximum short-circuit current at the connection point is an important indicator for dimensioning the required switching capacity of protective elements, fuses/circuit breakers.

Protection elements should be dimensioned so that the maximum permissible short-circuit current can be reliably switched by the selected protection element.

The calculated minimum short-circuit current at the connection point is an important indicator for the maximum permissible tripping time of protection elements, fuses/circuit breakers.

Protection elements should be dimensioned so that at the minimum short-circuit current expected, these still reliably trip within the maximum permissible trip time specified by the device manufacturer in order to guarantee protection for personnel and avoid the risk of fire.

When connecting the machine, using a suitable measuring device (according to DIN, EN, IEC 61557-3; VDE 0413-3) at the connection point of the drive system, the short-circuit current should be determined and the overcurrent protective devices installed checked to ensure that they comply with these operating conditions.

The measuring results and installed protection elements must be documented so that they can be subsequently verified when required.

---

**Warning**

For trial operation when connected to line supplies that do not have adequate short-circuit power (system default level), the protection elements should be adapted so that they trip within approx. 10 ms in the case of a fault, as otherwise there is a risk of significant damage to the device or fire.

It is not permissible to overdimension the protection elements.

---

**Note**

The recommended circuit breakers are sufficient for a maximum short-circuit current (SCCR) < 65 kA of the drive lineup.

For line supplies that deviate from this with a smaller or higher line short-circuit power, these can or must be appropriately re-dimensioned.

---

## 7.3 Overcurrent protective devices, transformers and main switch

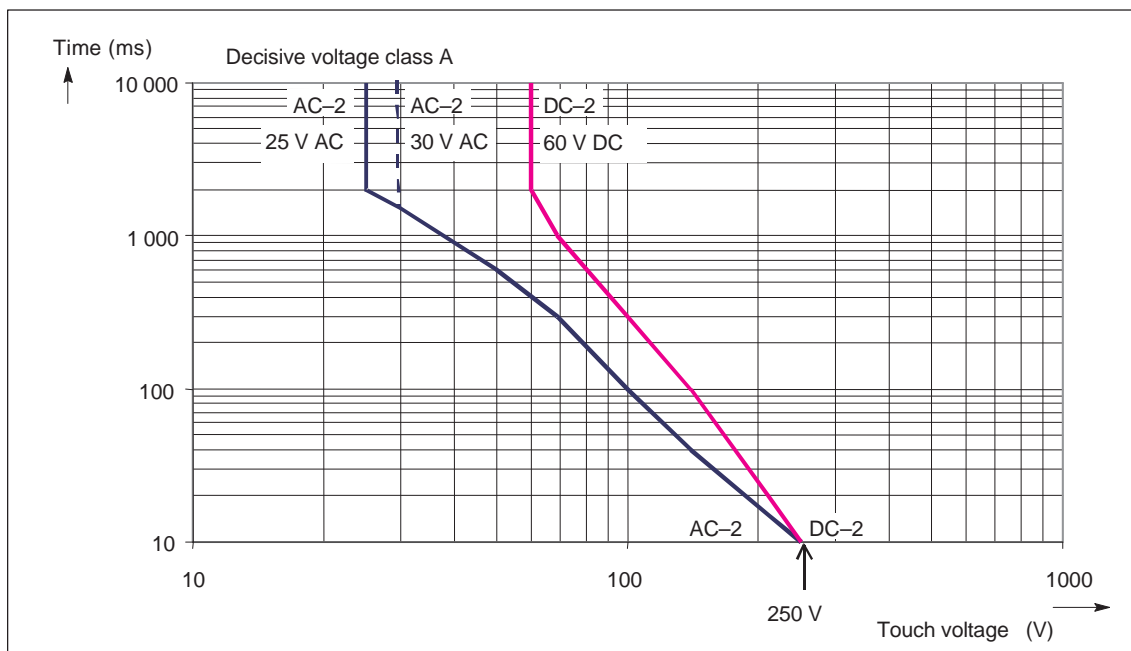

Fig. 7-8 Permissible tripping time of fuses/circuit-breakers

**Note**

The dotted line for AC-2 applies if there is only one single circuit with DVC A. The solid line applies if there is more than one circuit with DVC A.

For timely tripping of fuses, the loop resistance as well as the vector group of the line supply transformer being fed must satisfy the requirement that the touch voltage of the devices is switched off by the provided fuses within the permissible tripping time (see Fig. 7-8 in accordance with EN 61800-5-1 Ed. 2007).

## 7.3 Overcurrent protective devices, transformers and main switch

## 7.3.2 Assigning autotransformers to the I/R modules

**Note**

If, for I/R modules, a transformer is used, this does **not** replace the external commutating reactor.

When using a transformer, from NE module  $\geq 10$  kW onwards, Order No.: 6SN114□-1□□0□-0□□1), an overvoltage limiter module must be used (Order No.: 6SN1111-0AB00-0AA0).

Table 7-8 Autotransformers for 480/440 V input voltage

	I/RF module 16/21 kW	I/RF module 36/47 kW	I/RF module 55/71 kW	I/RF module 80/104 kW	I/RF module 120/156 kW
Nominal power rating [kVA]					
• Autotransf. IP00/IP20	21	46.5	70.3	104	155
• Autotransformer IP23	18.9	42	63.3	93.5	140
Input voltage [V]	3-ph. 480/440 V AC $\pm 10\%$ ; 50 Hz $- 10\%$ to 60 Hz $+ 10\%$				
Output voltage [V]	3-ph. 400 V AC				
Vector group	Yna0; neutral point N can be loaded only with maximum 10% if not corrected with an N (= MP) line supply!				
Permiss. ambient temperature					
• Operation [°C]	$-25$ to $+40$ , for power derating up to $+55$ °C				
• Storage/transport [°C]	$-25$ to $+80$				
Humidity classification in accordance with DIN EN 60721-3-3	Class 3K5, moisture condensation and formation of ice not permissible Low air temperature 0 °C				
Degree of protection acc. to DIN EN 60529 (IEC 60529) IP00/IP20/IP23	<ul style="list-style-type: none"> <li>Degree of protection IP 00: □ <math>\rightarrow</math> Order No. A</li> <li>Degree of protection IP 23: □ <math>\rightarrow</math> Order No. C<sup>2)</sup></li> </ul>				
Order No. mdexx GmbH Richard-Dunkel_Straße 120 28199 Bremen Germany Tel.: +49 421 51 25 - 0 E-Mail: info@mdexx.de	4AP2796- 0EL40-2X□0	4AU3696- 0ER20-2X□0	4AU3696- 2NA00-2X□0	4AU3996- 0EQ80-2X□0	IP00: 4BU4395- 0CB50-8B IP20: 4BU4395- 0CB58-8B IP23: 4BU4395- 0CB52-8B
Power loss [W]					
• Autotransf. IP00/IP20	160 <sup>1)</sup>	430	550	700	700
• Autotransformer IP23	135	370	460	590	600
Short-circuit voltage uk [%]	$\leq 3$				
Conn. cross-section, max. primary/secondary side	16 mm <sup>2</sup>	35 mm <sup>2</sup>	70 mm <sup>2</sup>	Flat termination <sup>3)</sup>	
Fuse, primary side	35 A gL	80 A gL	125 A gL	160 A gL	224 A gL
Weight [kg], approx. for					
• Degree of prot. IP 00	29	52	66	95	135
• Degree of prot. IP 20/23	40	70	85	115	155

## 7.3 Overcurrent protective devices, transformers and main switch

Table 7-8 Autotransformers for 480/440 V input voltage, continued

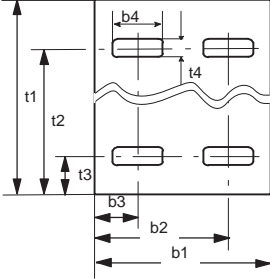
	I/RF module 16/21 kW	I/RF module 36/47 kW	I/RF module 55/71 kW	I/RF module 80/104 kW	I/RF module 120/156 kW
Connection	Terminals: 1U1/1U3/1V1/1V3/1W1/1W3/2U1/2V1/2W1/N			Flat termination connections	
	Terminals: 1U1 to 1W1 = 480 V input, 1U3 to 1W3 = 440 V input, 2U1 to 2W1 = 400 V output, N = neutral point				
Dim. (L x W x H) approx.[mm] • Autotransf. IP00/IP20 • Autotransformer IP23	270x192x250 351x330x395	370x220x330 460x465x555	370x240x340 460x465x555	420x260x370 460x465x555	480x220x420 565x460x520
Drilling template Dimensions in mm Footprint, view from the top					
	t1 = 270/351 t2 = 235 t3 = 35 t4 = 10 b1 = 192/330 b2 = 140.5 b3 = 39.5 b4 = 18 Height 250/395	t1 = 370/460 t2 = 317 t3 = 53 t4 = 10 b1 = 220/465 b2 = 179 b3 = 41 b4 = 18 Height 330/555	t1 = 370/460 t2 = 317 t3 = 53 t4 = 10 b1 = 240/465 b2 = 189 b3 = 51 b4 = 18 Height 340/555	t1 = 420/460 t2 = 368 t3 = 52 t4 = 10 b1 = 260/465 b2 = 200.5 b3 = 59.5 b4 = 18 Height 370/555	t1 = 480/565 t2 = 418 t3 = 62 t4 = 15 b1 = 220/460 b2 = 217.5 b3 = 62.5 b4 = 22 Height 420/520

- 1) Not IP20
- 2) 10% power derating required
- 3) FL = flat termination, hole  $\varnothing$  9 mm

## 7.3 Overcurrent protective devices, transformers and main switch

Table 7-9 Autotransformer for a 220 V input voltage

	I/RF module 16/21 kW	I/RF module 36/47 kW	I/RF module 55/71 kW	I/RF module 80/104 kW	I/RF module 120/156 kW
Nominal power rating [kVA] • Autotransf. IP00/IP20 • Autotransformer IP23	21 18.9	46.5 42	70.3 63.3	104 93.5	155 140
Input voltage [V]	3-ph. 220 V AC $\pm$ 10%; 50 Hz $-$ 10% to 60 Hz + 10%				
Output voltage [V]	3-ph. 400 V AC				
Vector group	Yna0 Neutral point N can be loaded only with maximum 10% if not corrected with an N (= MP) line supply!				
Permiss. ambient temperature • Operation [°C] • Storage/transport [°C]	-25 to +40, for power derating up to +55 °C -25 to +80				
Humidity classification in accordance with DIN EN 60721-3-3	Class 3K5 condensation and formation of ice excluded				
Degree of protection acc. to DIN EN 60529 (IEC 60529) IP00/IP20/IP23	<ul style="list-style-type: none"> <li>Degree of protection IP 00: □ <math>\rightarrow</math> Order No. 0</li> <li>Degree of protection IP 20: □ <math>\rightarrow</math> Order No. 8</li> <li>Degree of protection IP 23: □ <math>\rightarrow</math> Order No. 2 <sup>2)</sup></li> </ul>				
Order No. mdexx GmbH Richard-Dunkel_Straße 120 28199 Bremen Germany Tel.: +49 421 51 25 - 0 E-Mail: info@mdexx.de	IP00: 4AU3696- 0ER30-2XA0 IP23: 4AU3696- 0ER30-2XC0	4BU4395- 0CB6□-8B	4BU4595- 0BD0□-8B	4BU5295- 0AE4□-8B	4BU5495- 1AA1□-8B
Power loss [W] • Autotransf. IP00/IP20 • Autotransformer IP23	550 <sup>1)</sup> 460	900 <sup>1)</sup> 760	980 <sup>1)</sup> 830	1350 <sup>1)</sup> 1150	1650 1400
Short-circuit voltage uk [%]	$\leq$ 3				
Conn. cross-section, max. primary/secondary side	16/16 mm <sup>2</sup>	70/50 mm <sup>2</sup>	95/70 mm <sup>2</sup>	Flat termination <sup>3)</sup>	
Fuse, primary side	63 A gL	160 A gL	224 A gL	300 A gL	500 A gL
Weight [kg], approx. for • Degree of prot. IP 00 • Degree of prot. IP 20/23	57 75	110 130	155 175	215 275	310 370
Terminal arrangement	1U1 to 1W1 = 220 V input, 2U1 to 2W1 = 400 V output, N = neutral point				
Dim. (L x W x H) approx.[mm] • Autotransf. IP00/IP20 • Autotransformer IP23	370x220x330 460x465x555	480x230x430 565x290x520	480x300x430 565x460x520	530x290x520 900x600x720	590x320x585 900x600x720

7.3 Overcurrent protective devices, transformers and main switch

Table 7-9 Autotransformer for a 220 V input voltage, continued

	I/RF module 16/21 kW	I/RF module 36/47 kW	I/RF module 55/71 kW	I/RF module 80/104 kW	I/RF module 120/156 kW
Max. dimensions Drilling template in mm Footprint, view from the top					
	t1 = 370/460 t2 = 317 t3 = 53 t4 = 10 b1 = 220/465 b2 = 179 b3 = 41 b4 = 18 Height 330/555	t1 = 480/565 t2 = 418 t3 = 62 t4 = 15 b1 = 230/460 b2 = 205 b3 = 50 b4 = 22 Height 430/520	t1 = 480/565 t2 = 418 t3 = 62 t4 = 15 b1 = 300/460 b2 = 241 b3 = 59 b4 = 22 Height 430/520	t1 = 530/900 t2 = 470 t3 = 60 b1 = 290/600 b2 = 254 b3 = 71 d1 = 12.5 Height 520/720	t1 = 590/900 t2 = 530 t3 = 60 b1 = 320/600 b2 = 279 b3 = 81 d1 = 15 Height 585/720

- 1) Not IP20
- 2) 10% power derating required
- 3) FL = flat termination, hole  $\varnothing$  9 mm

**Operating conditions for all transformers**

The permissible current of the transformers, reactors etc. depends on the ambient temperature and the installation altitude. The permissible current/power rating of transformers and reactors is as follows:

$$I_n \text{ (PD) reduced} = c \times I_n \text{ (PD)}$$

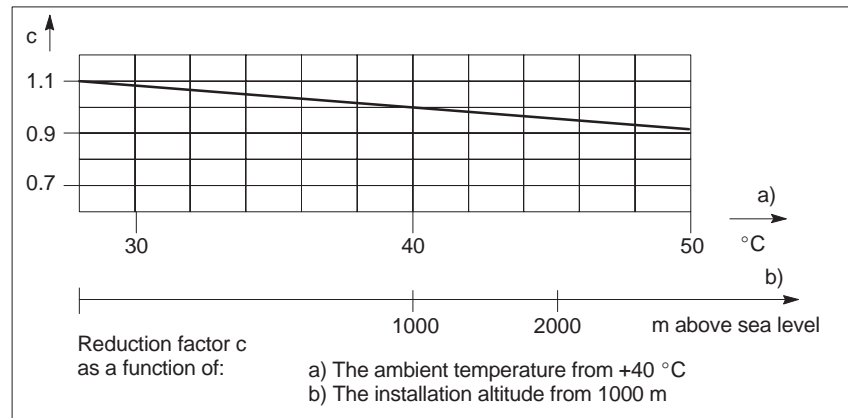

Fig. 7-9 Reduction factor (derating) c



## 7.3 Overcurrent protective devices, transformers and main switch

## 7.3.3 Assigning isolating transformers to the I/R modules

Table 7-10 Matching transformers with separate windings for 50 Hz/60 Hz line supplies

	I/RF module 16 kW	I/RF module 36 kW	I/RF module 55 kW	I/RF module 80 kW	I/RF module 120 kW
Nominal rated power [kVA]	21	47	70	104	155
Power loss, max. [W]	650	1200	2020	2650	3050
Vector group	Yyn0 neutral point N can only be loaded with maximum 10%!				
Short-circuit voltage uk [%]	≤ 3				
Degree of protection acc. to DIN EN 60529 (IEC 60529)	<ul style="list-style-type: none"> <li>Degree of protection IP 00: □ → Order No. 0</li> <li>Degree of protection IP 20: □ → Order No. 8</li> <li>Degree of protection IP 23: □ → Order No. 2 <sup>1)</sup></li> </ul>				
Humidity classification in accordance with DIN EN 60721-3-3	Class 3K5 condensation and formation of ice excluded				
Permiss. ambient temperature					
• Operation °C	-25 to +40, for power derating up to +55				
• Storage/transport °C	-25 to +80				
Approx. weight for					
• Degree of prot. IP 00 [kg]	120	200	300	425	600
• Degree of prot. IP 20/23[kg]	131	216	364	536	688
Dim. (L x W x H) approx.[mm]	480 x 209 x 420	480 x 267 x 420	630 x 328 x 585	780 x 345 x 665	780 x 391 x 665
Max. conn., secondary [mm <sup>2</sup> ]	16	35	70	Cable lug according to DIN 46235	
Input voltage, 3-ph. 575 V – 500 V – 480 V AC ± 10%; 50 Hz – 10% to 60 Hz + 10%					
Rated input current [A]	26	58	87	127	189
Max. conn., primary [mm <sup>2</sup> ]	16	35	50	70	Cable lug according to DIN 46235
Order No. according to Catalog PD10	4BU43 95-0SA7□-0C	4BU47 95-0SC3□-0C	4BU55 95-0SA4□-0C	4BU58 95-0SA6□-0C	4BU60 95-0SA6□-0C
Input voltage, 3-ph. 440 V – 415 V – 400 V AC ± 10%; 50 Hz – 10% to 60 Hz + 10%					
Rated input current [A]	31	69.5	104	154	228
Max. conn., primary [mm <sup>2</sup> ]	16	35	70	70	Cable lug according to DIN 46235
Order No. according to Catalog PD10	4BU43 95-0SA8□-0C	4BU47 95-0SC4□-0C	4BU55 95-0SA5□-0C	4BU58 95-0SA7□-0C	4BU60 95-0SA7□-0C
Input voltage, 3-ph. 240 V – 220 V – 200 V AC ± 10%; 50 Hz – 10% to 60 Hz + 10%					
Rated input current [A]	62	138.5	210	309	450
Max. conn., primary [mm <sup>2</sup> ]	35	70	Cable lug according to DIN 46235		
Order No. according to Catalog PD10	4BU43 95-0SB0□-0C	4BU47 95-0SC5□-0C	4BU55 95-0SA6□-0C	4BU58 95-0SA8□-0C	4BU60 95-0SA8□-0C

<sup>1)</sup> For degree of protection IP 23, a 10% power derating must be taken into account  
 In conformance with the Standards with regulation: EN61558/VDE0532  
 Insulation Class: T40/b-H

### 7.3.4 Assignment of the isolating transformer to the UI modules

Table 7-11 Matching transformers with separate windings for 50 Hz/60 Hz line supplies

	UI module 5 kW <sup>2)</sup>	UI module 10 kW <sup>2)</sup>	UI module 28 kW
Nominal rated power [kVA]	8	16	47
Power loss, max. [W]	520	650	1200
Vector group	YYn0 neutral point N can only be loaded with maximum 10%!		
Short-circuit voltage uk [%]	≤ 10		
Degree of protection to DIN EN 60529 (IEC 60529)	<ul style="list-style-type: none"> <li>Degree of protection IP 00: □ → Order No. 0</li> <li>Degree of protection IP 20: □ → Order No. 8</li> <li>Degree of protection IP 23: □ → Order No. 2 <sup>1)</sup></li> </ul>		
Humidity rating EN 60721-3-3	Class 3K5 condensation and formation of ice excluded		
Permiss. ambient temperature	<ul style="list-style-type: none"> <li>Operation °C -25 to +40, for power derating up to +55</li> <li>Storage/transport °C -25 to +80</li> </ul>		
Approx. weight for			
• Degree of prot. IP 00 [kg]	55	70	200
• Degree of prot. IP 20/23 [kg]	65	95	216
Dim. (L x W x H) approx. [mm]	360 x 268 x 320	420 x 262 x 370	480 x 267 x 420
Max. conn., secondary [mm <sup>2</sup> ]	6	6	35
Input voltage, 3-ph. 575 V – 500 V – 480 V AC ± 10%; 50 Hz – 10% to 60 Hz + 10%			
Rated input current [A]	10	20	58
Max. conn., primary [mm <sup>2</sup> ]	6	6	35
Order No. according to Catalog PD10	4AU36 95-0SB0□-0CN2	4AU39 95-0SA3□-0CN2	4BU47 95-0SC3□-0C
Input voltage, 3-ph. 440 V – 415 V – 400 V AC ± 10%; 50 Hz – 10% to 60 Hz + 10%			
Rated input current [A]	12	24	70
Max. conn., primary [mm <sup>2</sup> ]	6	16	35
Order No. according to Catalog PD10	4AU36 95-0SB1□-0CN2	4AU39 95-0SA4□-0CN2	4BU47 95-0SC4□-0C
Input voltage, 3-ph. 240 V – 220 V – 200 V AC ± 10%; 50 Hz – 10% to 60 Hz + 10%			
Rated input current [A]	26	47	140
Max. conn., primary [mm <sup>2</sup> ]	6	16	70
Order No. according to Catalog PD10	4AU36 95-0SB2□-0CN2	4AU39 95-0SA5□-0CN2	4BU47 95-0SC5□-0C

1) For degree of protection IP 23, a 10% power derating must be taken into account

2) Not degree of protection IP 20

#### Note

UI modules can be operated on TN line supplies from 360 V (with derating!) to 480 V without a matching transformer.

## 7.3 Overcurrent protective devices, transformers and main switch

## 7.3.5 Assigning the main switches

The main switches must be chosen appropriately for the machine (scope of the installation), the supply line characteristics (voltage, short-circuit power), regional regulations for plant/machine constructors.

Recommendation:

Siemens 3LD.../3KA... switch types (as listed in the SIEMENS "Low-Voltage Switchgear" catalog)

Table 7-12 Assignment of the main and auxiliary switches, e.g. only one NE module and short-circuit power SCCR 65 kA

For UI modules					
	5 kW	10 kW	28 kW		
Switch type	3LD2103-0TK... + 3LD9220-3B	3LD2504-0TK... + 3LD9250-3B	3LD2704-0TK... + 3LD9280-3B		
For I/R modules					
	16 kW	36 kW	55 kW	80 kW	120 kW
Switch type	3LD2504-0TK... + 3LD9250-3B	3LD2704-0TK... + 3LD9280-3B	3KA5330-1EE01 + 3KX3552-3EA01	3KA5530-1EE01 + 3KX3552-3EA01	3KA5730-1EE01 + 3KX3552-3EA01

## 7.3.6 Use of a leading contact for line isolating device

For various plant and system configurations the use and the correct connection of a leading contact (integrating terminal 48) for the switching element is either absolutely necessary or not required. In this connection, switching elements are:

- Power disconnectors (mains switch, line supply contactor)

**Note**

During the shutdown, to prevent damaging overvoltages that can damage parallel-operated loads, terminal 48 of the NE modules must be switched off 10 ms before deenergizing the line supply contacts.

Main switches (breakers) with leading auxiliary contact can be used to ensure that terminal 48 of the NE modules is deenergized using a leading contact.

Leading shutdown is not required for certain drive configurations.  
For information refer to Section 7.3.6.

**Note**

If the objective is that an application is not to have a leading contact over the complete power range of the infeed modules, then this can be implemented using the following measures:

- Changing over from any present I/R modules to unregulated infeed (this is generally the case for 480 V applications).
- Deactivating the regenerative feedback if I/R modules are being used.

The I/R modules then operate as UI modules and can be operated with additional loads connected to a switching element without leading contact.

**Leading contact is absolutely necessary**

For the configurations that are now described, a leading contact for the switching element is absolutely necessary:

- If one or more I/R modules are connected, together with other loads, through a switching element.
- If NE modules having different power classes are connected together to one switching element. In this case, the restrictions, described on the following page, must be carefully fulfilled.

The following diagram shows two examples where a leading contact is absolutely necessary.

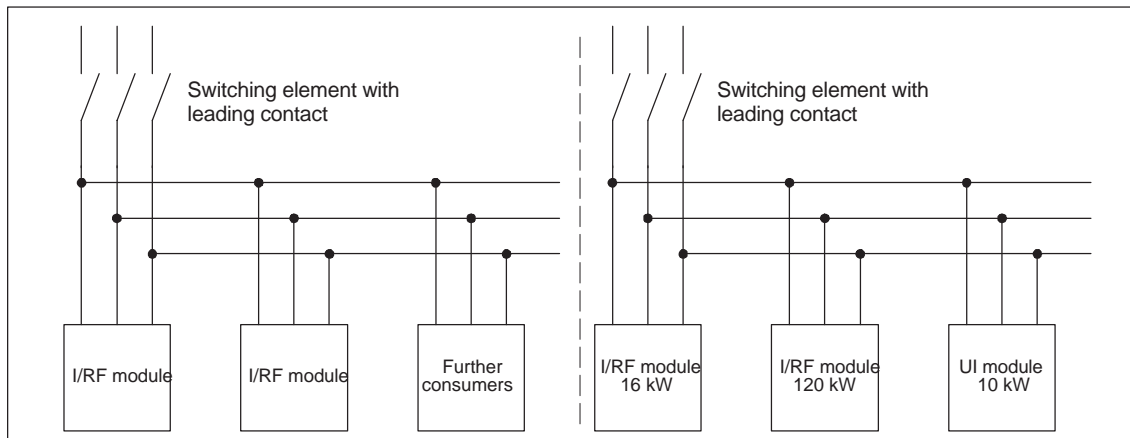

Fig. 7-10 Examples of a configuration where a leading contact is required

### Leading contact is not absolutely required

#### Caution

If switching elements are used without leading contact, then it must be absolutely ensured that after powering-down and -up the NE module again, terminal 48 (start/contact control) is deenergized in order to activate the precharging circuit. If this is not the case, then high re-charging currents (similar to short-circuit currents) can occur when powering-up again. These re-charging currents are not limited by the pre-charging circuit. This can trip the fuse or damage/destroy the NE module.

For the subsequently described configurations, it is not absolutely necessary that a leading contact is used for the switching element:

- Only one NE module is connected to the switching element.

#### Caution

When using I/R modules, no additional loads may be connected to the switching element.

- Connection of NE modules with the same power class to one switching element. In this case, the restrictions for connecting several NE modules to a switching element must be carefully observed (refer to the following page).

#### Caution

If I/R modules are connected together with UI modules to one switching element, overvoltage limiter modules must be used.

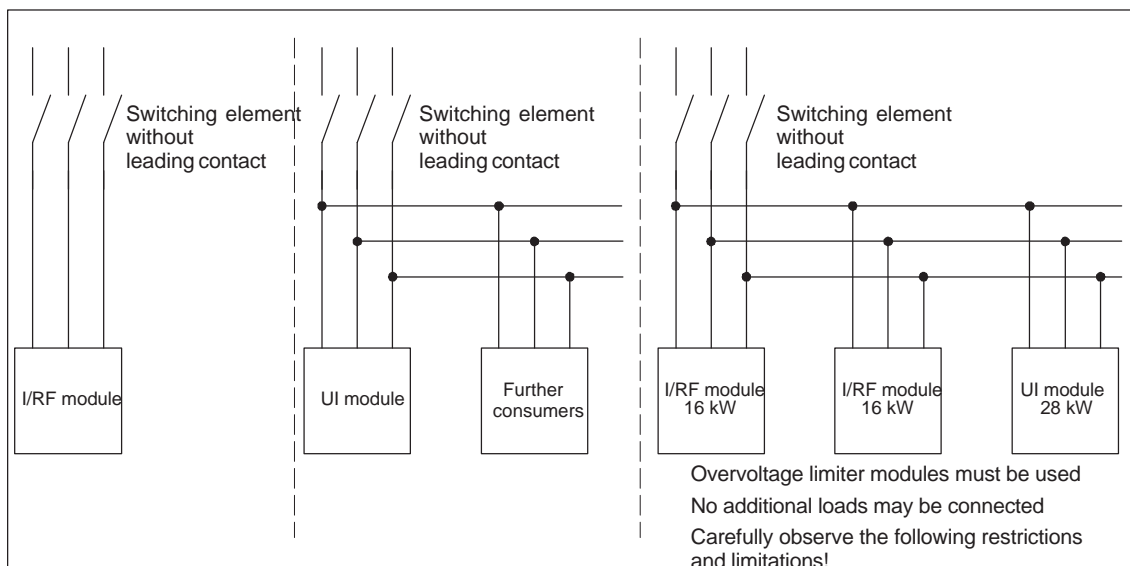

Fig. 7-11 Examples of three configurations that do not require a leading contact

## 7.3 Overcurrent protective devices, transformers and main switch

## Summary

Table 7-13 Using a leading contact for SIMODRIVE units

Unit connected to the switching element	Leading contact required	No leading contact	Remarks	Risks
Only UI modules	–	✓	–	–
Only UI modules with additional loads	–	✓	–	–
Only I/R modules (without additional loads)	–	✓	The appropriate restrictions must be carefully observed.	If these restrictions are not carefully observed, then smaller rating modules can be destroyed by the modules that are presently regenerating when the switching element is opened.
Only modules that can regenerate into the line supply with additional loads	✓	–	–	If a leading contact is not used, then the additional connected loads could be destroyed by overvoltages
I/R modules together with UI modules	–	✓	It is necessary to use overvoltage limiter modules.	If an overvoltage limiter module is not used, when the switching element is opened the module could be destroyed by other modules that are regenerating at that time.
			The appropriate restrictions must be carefully observed.	If these restrictions are not carefully observed, then smaller rating modules can be destroyed by the modules that are presently regenerating when the switching element is opened.
I/R modules together with UI modules and additional loads	✓	–	–	If a leading contact is not used, then the additional connected loads could be destroyed by overvoltages.

## 7.4 Line filters for I/R and UI modules

### 7.4.1 General information

#### Description

The line filters limit the cable-borne noise and disturbances, originating from the converter units, to permissible EMC values for industrial environments. If the system is consequentially executed in-line with the Configuration Manual and the EMC Guidelines for SIMODRIVE, SINUMERIK, SIROTEC, then the prerequisites are created so that the limit values at the installation location will be in compliance with the EU Directives for EMC.

The line filters can be used both for sinusoidal current as well as squarewave current operation.

The mounting/installation and connection regulations as listed in Chapter 9.1 must be carefully observed.

For more detailed information regarding an EMC-correct design, refer also to the EMC Guidelines for SINUMERIK (Order No.: 6FC5297-0AD30-0AP1).

Other suitable measures can also be adopted to comply with the EMC limits. An EMC examination is necessary in particular cases.

#### Note

The line supply connection conditions as specified in Section 7.1 must always be observed. If the line supply does not comply with the requirements according to EN-IEC 61000-2-4 Class 3, then the filters could be overloaded.

The use of a matching transformer does not mean that the HFD reactor or the line filter can be omitted.

Optional line filter rows that are coordinated with the power range are also available with the SIMODRIVE 611 digital converter system. These line filters differ with regard to the frequency range in which they reduce the conducted emissions.

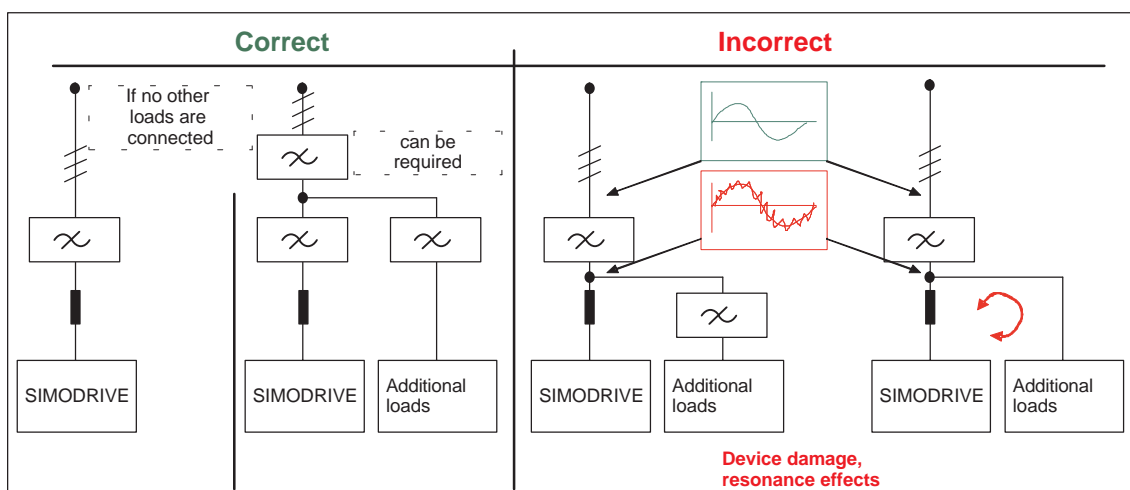

Fig. 7-12 Wiring information and instructions

**Wideband line filter**

Wideband line filters function in the frequency range from 2 kHz to 30 MHz. Load frequency harmonics are effectively limited using a wideband line filter. They are required when sensitive loads, such as electronic power supplies, etc., are operated on the same line supply. This can prevent impairment, damage, and premature aging of these loads.

**Basic line filter**

Basic line filters function in the frequency range from 150 kHz to 30 MHz. This especially suppresses disturbances for radio-based services.

**Safety information****Caution**

The line filters are only suitable for the direct connection to TN systems.

The line filters listed conduct a high leakage current over the PE conductor. A permanent PE connection for the line filter or control cabinet is required due to the high leakage current of the line filters.

Only the line filters described in this Configuration Manual should be used. Other line filters can cause line harmonics that can interfere with or damage other loads powered from the line supply.

It is not permissible to connect other loads after the line filter.

Measures according to DIN EN 61800-5-1 must be taken, e.g. a PE conductor  $\geq 10 \text{ mm}^2$  CU or fit an additional connection terminal for a PE conductor with the same cross-section as the original PE conductor.

**Danger**

The 100 mm clearances above and below the components must be observed. The mounting position must ensure that cool air flows vertically through the filter. This prevents thermal overloading of the filter.

A hazardous voltage will be present at the terminals for up to 30 minutes after the system has been shutdown depending on the DC link capacitance.

For this reason, opening the device or removing the cover is permitted only after 30 minutes have elapsed since the device was switched to the voltage-free state. All covers must be reattached before the line voltage is switched on.

**Danger of death!**

Touching live terminals, cables or device parts can result in serious injury or death!

**Note**

If the system is subject to a high-voltage test using AC voltage, any existing line filter must be disconnected in order to obtain a correct measurement result.



### 7.4.2 Wideband line filter

#### Description

The damping characteristics of wideband line filters not only conform with the requirements of EMC standards for the frequency range of 150 kHz to 30 MHz but also include low frequencies as of 2 kHz. As a result, these line filters have an extended function area, which means that they can, to a certain extent, be used regardless of the machine installation location and any unknown line properties (e.g. line impedance).

The Wideband Line Filters should be preferably used.

For sinusoidal current operation, the total length of the power cables from the line filter should not exceed 350 m and for square-wave current operation, should not exceed 500 m!

#### Interfaces

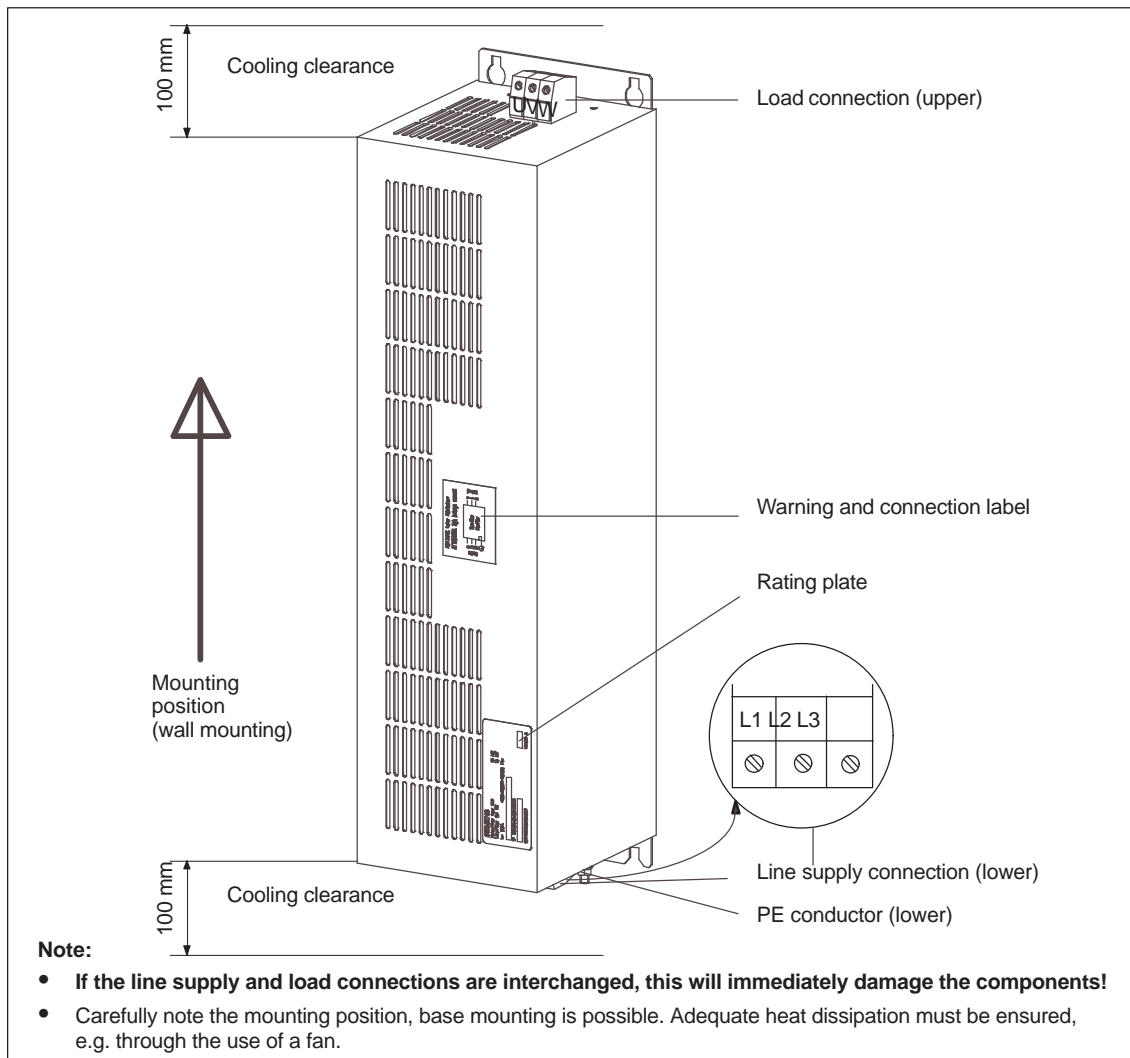

Fig. 7-13 Wideband line filter (example 16 kW)

**Caution**

The connections/terminals may not be interchanged:

- Incoming line supply cable to LINE/NETZ L1, L2, L3
- Outgoing cable to the line reactor to LOAD/LAST U, V, W

If this is not observed, the line filter could be damaged.

Table 7-14 Assigning the wideband filters to the I/R modules

	I/RF module 16/21 kW	I/RF module 36/47 kW	I/RF module 55/71 kW	I/RF module 80/104 kW	I/RF module 120/156 kW
Filter components	Line filter 16 kW	Line filter 36 kW	Line filter 55 kW	Line filter 80 kW	Line filter 120 kW
Rated AC current	30 A	67 A	103 A	150 A	225 A
Supply voltage	3-ph. 380 V – 10% ... 3-ph. 480 V AC + 10% (TN line supply) <sup>1)</sup> ; 50...60 Hz ± 10%				
Order number	6SL3000– 0BE21–6AA□	6SL3000– 0BE23–6AA□	6SL3000– 0BE25–5AA□	6SL3000– 0BE28–0AA□	6SL3000– 0BE31–2AA□
Mounting position	Wall or base/floor mounting, refer to Fig. 7-13				
Dimensions (W x H x D), approx.	130x480x150	130x480x245	130x480x260	200x480x260	300x480x260
Module width	Refer to dimension drawings, Chapter 12				
Weight, filter	9 kg	16 kg	19 kg	22 kg	34,5 kg
Power loss	70 W	90 W	110 W	150 W	200 W
Connection	16/10 mm <sup>2</sup> <sup>3)</sup> /1.5 Nm  PE, M5 studs/ 3 Nm <sup>2)</sup>	50 mm <sup>2</sup> /6 Nm  PE, M8 studs/13 Nm <sup>2)</sup>	50 mm <sup>2</sup> /6 Nm  PE, M8 studs/13 Nm <sup>2)</sup>	95 mm <sup>2</sup> /15 Nm  PE, M8 studs/13 Nm <sup>2)</sup>	95 mm <sup>2</sup> /15 Nm  PE, M8 studs/ 13 Nm <sup>2)</sup>
Terminals Line supply connection (line)	L1, L2, L3, PE	L1, L2, L3, PE	L1, L2, L3, PE	L1, L2, L3, PE	L1, L2, L3, PE
Terminals Load connection (load)	U, V, W	U, V, W	U, V, W	U, V, W	U, V, W
I <sub>rated</sub> fuse <sup>4)</sup>	35 A	80 A	125 A	160 A	250 A
Permissible ambient temperature	<ul style="list-style-type: none"> <li>• Operation [°C] 0 ... +40; maximum +55 at 0.6 • P<sub>rated</sub> of the I/R module</li> <li>• Storage/transport [°C] –25 ... +70</li> </ul>				
Cooler	Natural ventilation				
Degree of protection to EN 60529 (IEC 60529)	IP20				
DIN EN 61800-3 (IEC 61800-3)/VDE 0160-103 ra- dio interference suppres- sion	Limit value Class C2				

1) The permissible supply voltage of the system depends on the infeed module used.

2) For ring cable lugs to DIN 46234.

3) The first data applies for pin-type cable lugs, the second data applies for finely-stranded conductors without end sleeves

4) The fuse used must have this rated current. Recommendations for the fuses, refer to Table 7-6.

## 7.4 Line filters for I/R and UI modules

## 7.4.3 Line Filter

## Description

The line filters for UI modules attenuate frequencies in the range from 150 kHz up to 30 MHz. In conjunction with the consequential implementation of the system configuration according to the Configuration Manual and the EMC installation guideline for SIMODRIVE, SINUMERIK, SINAMICS S 120, when applying the installation guideline, the limit values at the installation location can be attained according to the EC directive EMC. The precondition is that the user takes into account the specific EMC guidelines at the installation location that may possibly apply and makes a final check. From the line filter, total cable lengths up to 500 m are possible!

Table 7-15 Assigning wideband line filters to the UI modules

	UI module 5/10 kW	UI module 10/25 kW	UI module 28/50 kW
Filter components	Line filter, 5 kW	Line filter, 10 kW	Line filter, 36 kW
Rated AC current	16 A	25 A	65 A
Order number	6SN1111-0AA01-1BA□ <sup>3)</sup>	6SN1111-0AA01-1AA□ <sup>3)</sup>	6SN1111-0AA01-1CA□ <sup>3)</sup>
Supply voltage	3-ph. 380 V – 10% ... 3-ph. 480 V AC + 10% (TN line supply) <sup>1)</sup> ; 50...60 Hz ± 10%		
Mounting position	Arbitrary (only for UI modules)		
Dimensions (W x H x D), approx.	156 x 193 x 81	156 x 281 x 91	171 x 261 x 141
Module width	Refer to dimension drawings, Chapter 12		
Weight, filter	3.8 kg	5.7 kg	12.5 kg
Power loss	20 W	20 W	25 W
Connection	4 mm <sup>2</sup> /1.5 Nm PE, M6 studs/3 Nm	10 mm <sup>2</sup> /1.5 Nm PE, M6 studs/3 Nm	50 mm <sup>2</sup> /6 Nm PE, M10 studs
Terminals Line supply connection (line)	L1, L2, L3, PE	L1, L2, L3, PE	L1, L2, L3, PE
Terminals Load connection (load)	U, V, W	U, V, W	U, V, W
I <sub>rated</sub> fuse <sup>2)</sup>	16 A	25 A	80 A
Permissible ambient temperature	0 ... +40; maximum +55 at 0.6 • P <sub>rated</sub> of the UI module		
• Operation [°C]	–25 ... +70		
• Storage/transport [°C]			
Cooler	Natural ventilation		
Degree of protection to EN 60529 (IEC 60529)	IP20		
DIN EN 61800-3 (IEC 61800-3)/VDE 0160-103 radio interference suppression	Limit value Class C 2.		

- 1) The permissible supply voltage of the system depends on the infeed module used.
- 2) The fuse used must have this rated current. Recommendations for the fuses, refer to Table 7-6.
- 3) Last position of the Order No. ≥ 1

#### 7.4.4 Basic line filter for I/R modules

##### Description

The basic line filter for I/R modules are designed for use in machines in which the conducted interference in the frequency range is to be reduced in accordance with EMC regulations.

The machine manufacturer must perform the EMC-compliant CE certification for the product before it is implemented.

---

##### Note

The company that puts the machine on the market takes full responsibility for ensuring CE EMC conformity and that the basic line filter is used correctly. The machine manufacturer (OEM) must have the machine conformity confirmed (e.g. by the EPCOS Company; <mailto:emv.labor@epcos.com>).

Basic Line Filters have properties similar to line filters that are generally available. The Basic Line Filter offered by Siemens, however have the advantage that they have been system-tested and released for SIMODRIVE 611. If they are used, taking into account the secondary conditions, then the Siemens system certificates for the converter system, such as CE, UL, etc. remain valid and do not result in loss of warranty!

---

The Basic Line Filters can be used in accordance with the following general conditions for ensuring CE conformity with regard to cable-borne interference:

- The machine/system must only be used in industrial networks.
- No. of axes <12.
- Total cable lengths <150 m (motor cables, power supply cable between the line filter and I/R module).

---

##### Caution

The connections/terminals may not be interchanged:

- Incoming line supply cable to LINE/NETZ L1, L2, L3
- Outgoing cable to the line reactor to LOAD/LAST L1', L2', L3'

If this is not observed, the line filter could be damaged.

---

## 7.4 Line filters for I/R and UI modules

## Interfaces

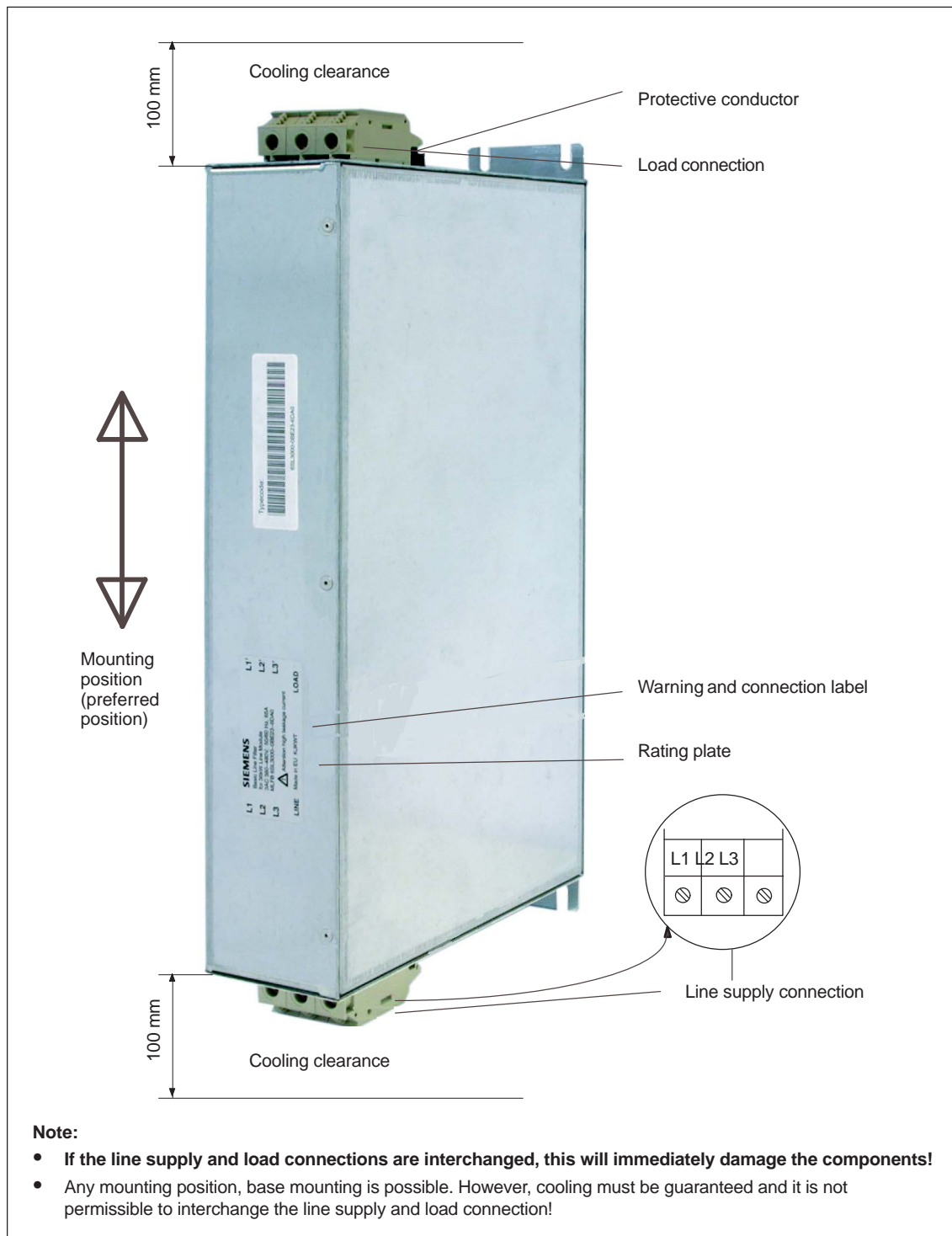

Fig. 7-14 Basic line filter for I/R module (example 36 kW)

Table 7-16 Assigning the basic line filters to the I/R modules

	I/RF module 16/21 kW	I/RF module 36/47 kW	I/RF module 55/71 kW
Filter components	Line filter 16 kW	Line filter 36 kW	Line filter 55 kW
Rated AC current	36 A	65 A	105 A
Supply voltage	3-ph. 380 V AC – 10% ... 3 –ph. 480 V + 10%/–15% < 1 min) (TN line supply) <sup>1)</sup> ; 47 ... 63 Hz		
Order number	6SL3000– 0BE21–6DA□	6SL3000– 0BE23–6DA□	6SL3000– 0BE25–5DA□
Mounting position	Wall or base/floor mounting, refer to Fig. 7-14		
Dimensions (W x H x D), approx.	50x429x226	75x433x226	100x466x226
Module width	Refer to dimension drawings, Chapter 12		
Weight, filter	5 kg	6.5 kg	11.5 kg
Power loss	16 W	28 W	41 W
Connection	10 mm <sup>2</sup> /1.5 Nm PE, M6 studs /3 Nm <sup>2)</sup>	35 mm <sup>2</sup> PE, M6 studs /3 Nm <sup>2)</sup>	50 mm <sup>2</sup> PE, M6 studs /3 Nm <sup>2)</sup>
Terminals Line supply connection (line)	L1, L2, L3, PE	L1, L2, L3, PE	L1, L2, L3, PE
Terminals Load connection (load)	L1', L2', L3', PE	L1', L2', L3', PE	L1', L2', L3', PE
I <sub>rated fuse</sub> <sup>4)</sup>	35 A	80 A	125 A
Compatibility, residual current protective devices	The discharge current is limited to approx. 110 mA in conjunction with a universally current sensitive residual current protective device and Siemens cables and the 150 m cable.		
Permissible ambient temperature	<ul style="list-style-type: none"> <li>• Operation [°C] 0 ... +40; maximum +55 at 0.6 • P<sub>rated</sub> of the I/R module</li> <li>• Storage/transport [°C] –25 ... +70</li> </ul>		
Cooler	Natural ventilation		
Degree of protection to EN 60529 (IEC 60529)	IP20		
DIN EN 61800-3 (IEC 61800-3)/VDE 0160-103 radio interference suppression	Limit value Class C 2		

- 1) The permissible supply voltage of the system depends on the infeed module used.
- 2) For ring terminal end in accordance with DIN 46234
- 3) Being prepared
- 4) The fuse used must have this rated current. Recommendations for the fuses, refer to Table 7-6.

### 7.4.5 Adapter sets

Adapter sets are available to facilitate an extremely compact installation of the 16 kW or 36 kW HFD reactor and the wideband filter. The mounting depth extends beyond the front plane of the drive group by 20 mm to 30 mm (dimension drawings, refer to Chapter 12).



Fig. 7-15 Construction with an adapter set

Table 7-17 Adapter sets

	I/RF module 16/21 kW	I/RF module 36/47 kW	I/RF module 55/71 kW	I/RF module 80/104 kW	I/RF module 120/156 kW
<b>Adapter set</b> Order No.	6SL3060- 1FE21-6AA□	6SN1162- 0GA00-0AA□	—	—	—

# Important Circuit Information

## 8.1 General information

---

### Note

The following circuit examples, information and descriptions are of a general nature and are not binding from a legal perspective. Every system must be adapted to ensure that it is complete and is correct for the particular application.

These circuit examples are intended to support the machinery construction OEM/user when integrating the SIMODRIVE 611 drive system – from the control perspective – into the overall control concept of his machine/system.

The users are responsible for ensuring that the overall control is in compliance with the Guidelines/Standards applicable for their particular application and the safety measures, derived from the hazard analysis/risk assessment to avoid injury to personnel and damage to machine, have been appropriately engineered and implemented.

---



### Warning

After the line isolating devices (main switch/breaker) or the line contactor have been opened, residual energy and hazardous touch voltages are still available at the power DC link of the drive group while the DC link capacitors discharge – max. 30 min. This means that these hazardous touch voltages are also available at components that are electrically connected to the DC link (terminals, cables, switching devices, motors, etc.). This must be carefully taken into consideration as part of the hazard analysis/risk assessment.

After 30 minutes, a residual voltage up to 60 V DC can still be present! Any damaged DC link covers must be replaced immediately. Operation of the plant with damaged DC link covers is not permitted!

Service personnel must ensure that the complete plant or system is actually in a no-voltage condition before they perform any service, maintenance and cleaning work!

---



### Warning

Before the drive group is powered-up or powered-down using the line supply isolating device (main switch/breaker) or a line contactor, terminal 48 start and/or terminal 63 pulse enable must be de-energized at the NE module. This can be realized, for example, using a leading auxiliary contact at the main switch.

For specific drive configurations it may not be necessary to use a leading contact when powering-down the NE modules. For information refer to Chapter 7.3.6.

---



## 8.1 General information

**Warning**

If the electronics power supply of the NE or monitoring module is connected in front of the commutating reactor directly at the line supply at the 2U1–2V1–2W1 terminals, with a six–conductor connection, then establish a connection between X181 (P500/M500) with the P600/M600 DC link as specified in Section 8.15.2!

**Warning**

In order to shutdown the system when the power fails using the DC link energy it is possible to have a connection between terminals P500/M500 and the DC link P600/M600.

**Warning**

When the NE module is connected–up using a six–conductor connection, and the electronics power supply is connected directly to the line supply, the jumpers in connector X181 at the NE module, inserted when the equipment is supplied, must be removed, refer to Section 8.15.

**Warning**

The input and output side connections at the line filter may not be interchanged in order to avoid damage to the equipment.

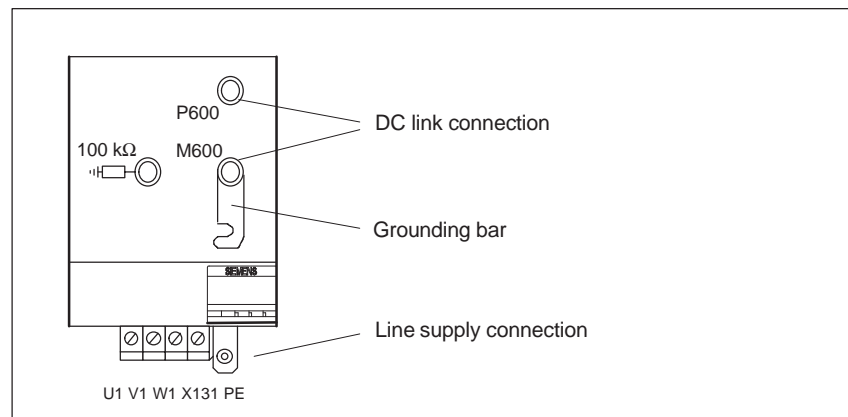

Fig. 8-1 NE module

**Warning**

The grounding bar is used for high-resistance connection and balancing of the DC link to the ground. It must always remain inserted.

The grounding bar must be opened only if a high-voltage test is performed.

**Note**

Electrically disconnecting the line supply from the power circuit of the drive group using the internal line contactor.

The coil circuit can be disconnected in order to reliably open (de-energize) the line contactor using external electrically isolated contacts via terminals NS1, NS2 at the NE module. The DC link is not pre-charged if the connection is missing when the unit is powered-up. The state of the contactor (whether it is open/de-energized) can be interrogated using terminals 111, 113, and 213.

The NS1, NS2 connection may only be opened if terminal 48 and/or terminal 63 are de-energized using a leading contact, or is simultaneously opened when these terminals are de-energized, refer to Section 8.7.

## 8.2 Infeed modules

### 8.2.1 Connecting several NE modules to a main switch

A maximum of six terminals 48 can be connected in parallel with one another in order to shut down a maximum of six NE modules with one leading contact of the main switch.

Maximum cable length with a 1.5 mm<sup>2</sup> cross-section: 150 m (2-wire conductor)

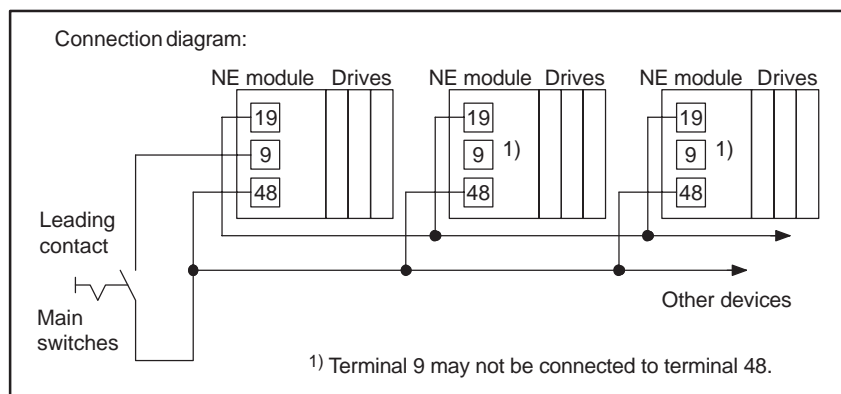

Fig. 8-2 Connection schematic, several NE modules connected to terminal 48

If enable signal terminals, e.g. terminal 663, are connected in parallel to terminal 48, then the number of NE modules must be appropriately reduced due to the higher current load connected to terminal 9.

#### Note

If the internal power supply at NE module 1 fails, then the remaining NE modules and drives that are connected are also inhibited. The drives "coast down" unbraked.

As an alternative to the limited current capability of the internal power supply via terminal 9, the enable voltage can be taken from an external 24 V PELV power supply.

In this case, the terminals 19 of the NE modules must be connected to the 0 V reference potential (ground) of the external power supply.

## 8.2.2 Application, mode of operation and connection of the line contactor

The infeed modules include an integrated line contactor that is listed in the Catalog.

The line contactor is electronically controlled (energized) via terminal 48.

In order to safely and reliably disconnect the DC link from the line supply, e.g. for stopping in an emergency situation, the coil circuit of the line contactor must additionally be interrupted via terminal NS1–NS2 using electrically isolated (floating) mechanical switching elements. This means that the electronic control has no influence when shutting down with electrical isolation. The cable routing to the connecting terminals must be safely and electrically de-coupled from the electronics.

Before or at the same time that connection NS1–NS2 is interrupted, the line contactor must always be opened using terminal 48.

The NC contact 111–213 of the line contactor, positively-driven with the power contacts, must be included in the feedback circuit of the external, safety-relevant EMERGENCY STOP switchgear combination (safety relay). This means that the function of the line contactor is cyclically monitored.

---

### Notice

If a protective separation of the power DC link from the supply line is required, for example, work must be performed on the power unit (connect/disconnect motor), also ensure that all parallel connections to the power infeed are electrically isolated using switching contacts. In this case, a possible user-specific external connection between the electronics power supply and the power DC link must be taken into consideration.

In order to shutdown the system when the power fails using the DC link energy, it is possible to have a connection between the P500/M500 and P600/M600 terminals.

If a safe electrical separation is required for this interconnection, the electronics, also possibly the monitoring module, must also be disabled or this electronic power supply – power DC link connection must be separated safely and reliably because otherwise the electronic power supply of the power DC link can be charged from the auxiliary DC link.

In the setting-up mode (only with 1FT5 motors), the connection between the electronics power supply and the power DC link must also be disconnected.

---

### 8.2.3 Timing diagram for the ready signal in the I/R module

The diagram below shows the initial state of terminals 48, 63, and 64 (jump-ered) when the I/R module is delivered. For a description of terminals 72 to 74, see Section 6.2.5.

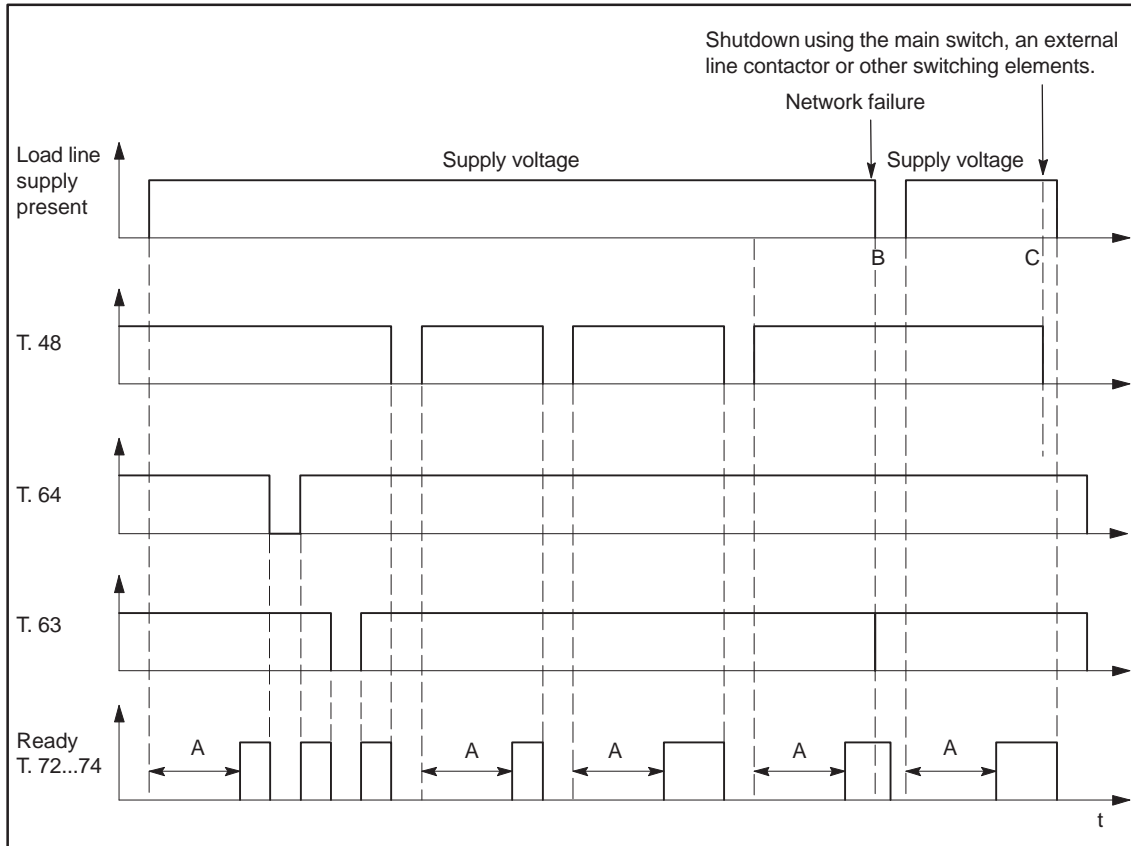

Fig. 8-3 Timing diagram for the ready signal in the I/R module

Switch S1.2 = OFF default setting in the I/R module "Ready signal"

- A** The ready relay can only pull-in if pre-charging has been completed and the internal line contactor has pulled-in.
- B** When the power fails (line supply failure), the I/R module is internally inhibited. This means that the I/R module can no longer regulate the DC link voltage which means that no braking energy can be fed back into the line supply (no regenerative feedback). The drives are **not** inhibited, but the ready relay drops-out after the power failure detection time with a delay that depends on the line supply impedances.
- C** When the line supply is switched off using the main switch or other switching elements, ensure that the terminal 48 on the I/R module is open at least 10 ms beforehand if other external parallel loads are also present in the switchgear cabinet (see Chapter 7.3.6).

### 8.3 Axis expansion using a monitoring module

#### 8.3.1 Connection example, power supply (standard)

See also Section 8.15, examples of correct and incorrect NE connection to the line supply

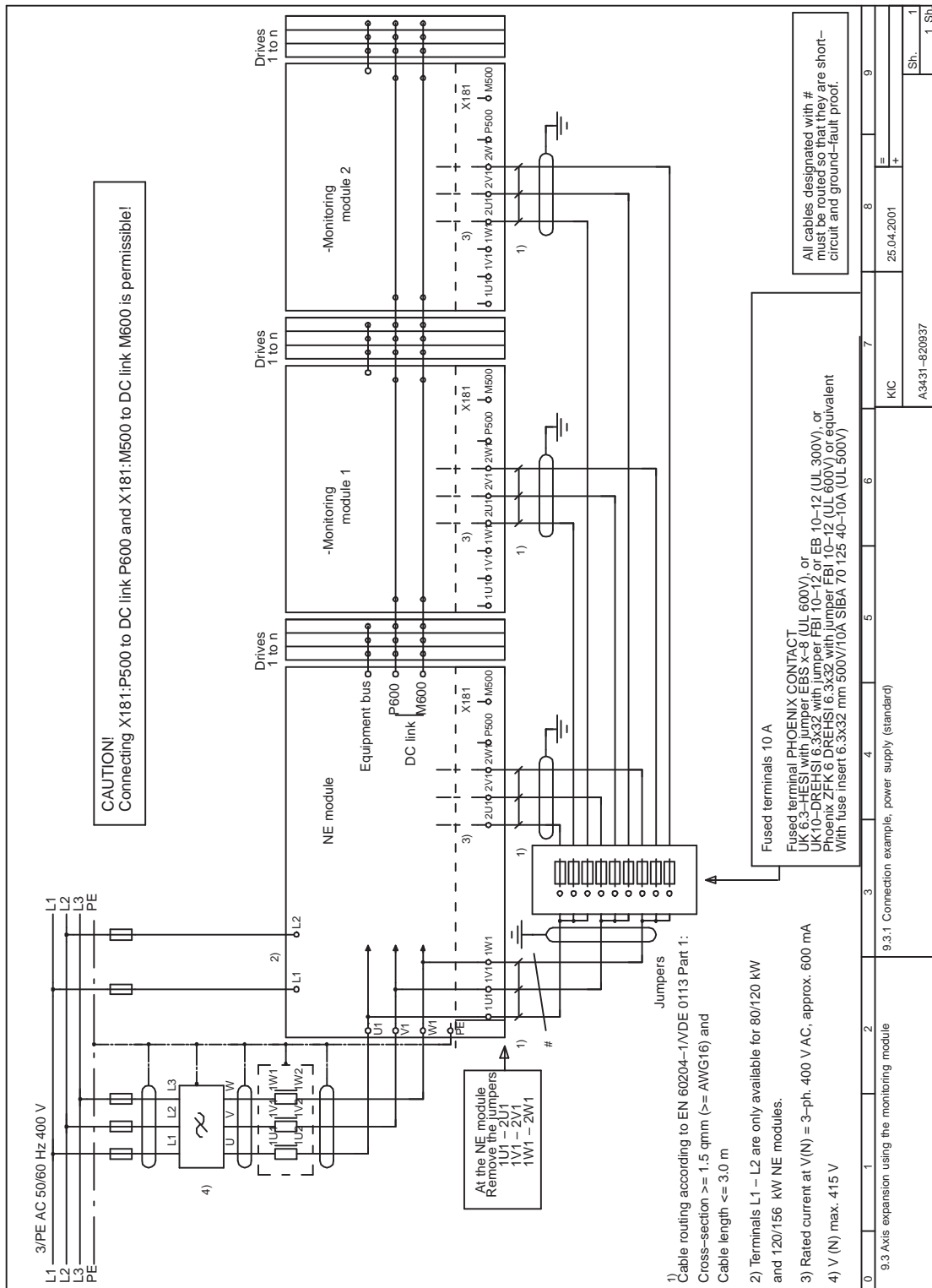

Fig. 8-4 Connection example, power supply (standard)

## 8.3 Axis expansion using a monitoring module

## 8.3.2 Connection example, pulse enable

## Instantaneous shutdown

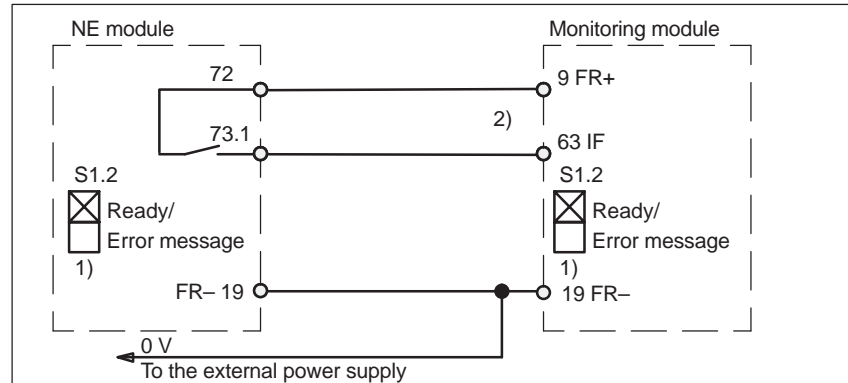

Fig. 8-5 Instantaneous shutdown, pulse enable

## Delayed shutdown

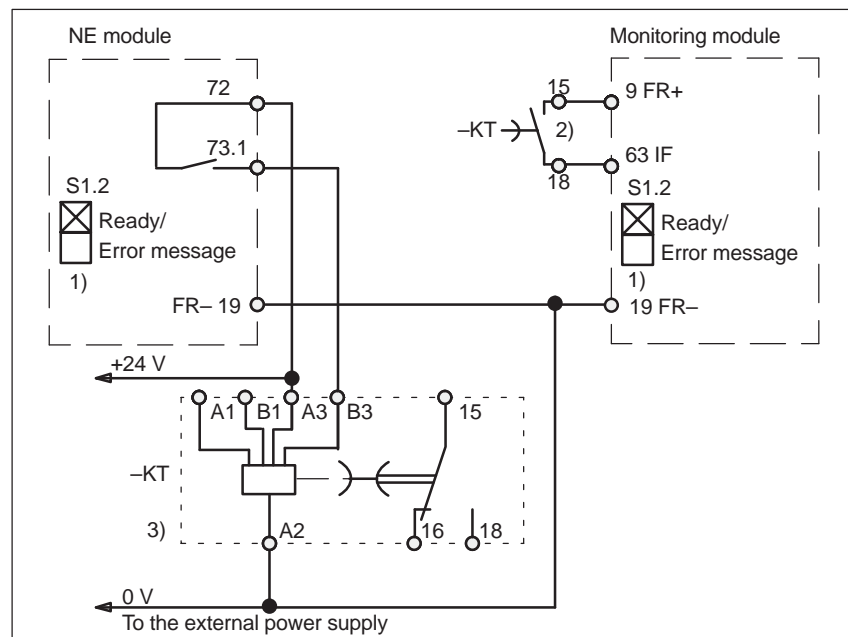

Fig. 8-6 Delayed shutdown, pulse enable

- 1) Settings, S1.2 Ready/fault signal, refer to Chapter 6.3.
- 2) The shutdown function is shown in a simplified fashion without the contacts of the drive-related control.
- 3) Time relay with delayed drop-out with auxiliary voltage, e.g. 3RP1505-1AP30,  $t_{(v)} \geq \text{max. braking time of the drives after the monitoring module.}$

### 8.3.3 Description of the interfaces and functions

#### General

The electronics power supply integrated in the NE module supplies the connected drive modules via the equipment bus; and, for the digital drive groups 611 digital, also the SINUMERIK controls 840D or 810D integrated in the group.

The number of modules that can be connected is limited. The connection power of the modules that can be connected is determined by adding the assessment factors regarding the electronics points (EP) and gating points (AP). If the power requirement exceeds the power rating of the NE module power supply, then the drive group must be expanded by one or more monitoring modules. The overall system then includes two or more electronic systems that are independent of one another.

Further, the charge limit of the DC link must be carefully observed (refer to Chapter 1.3).

Enable signals/commands or fault signals only effect the axes connected to a common equipment bus. The equipment bus is interrupted between the last axis after the NE module and the monitoring module.

#### Examples

- Connection example, power supply (standard) —> refer to Fig. 8-4.

The connection example shows the three-phase connection of the monitoring modules using fuse terminals after the power connection of the NE module.

As an alternative, the power supply of the monitoring module can also be taken from the P600/M600 power DC link through terminals P500/M500. In this case it must be taken into account that as a result of the limit imposed by the DC link pre-charging circuit in the NE module, a maximum of two monitoring modules with the associated axes may be connected. In this case it must be carefully observed that after the line contactor is opened, the DC link voltage decreases and therefore the power supply/communications to the drive modules is interrupted.

As an alternative to fused terminals, the following circuit-breaker can be used:

e.g. SIRIUS circuit-breaker, Order No. 3RV1011-1EA1□, (2.8–4 A)  
This should be set to between 3.5 and 4 A. Although the active current drain of the monitoring module is approx. 1 A, the rated current of the circuit-breaker should be selected somewhat higher due to the high-frequency harmonic components. When a connection cross-section of 1.5 mm<sup>2</sup> is used, this therefore guarantees adequate cable protection.

- Connection example, pulse enable —> refer to Section 8.3.2

The axes connected after the monitoring module may only be enabled if the NE module signaled ready/fault signal. This means that the power DC link has been charged-up and the internal line contactor has been closed. Any fault signals present at the NE module must act either instantaneously or delayed, interlocked with the pulse enable terminal 63 on the monitoring modules and the subsequent axes.



## 8.3 Axis expansion using a monitoring module

- Instantaneous shutdown, pulse enable → refer to Fig. 8-5

The ready/fault signal at terminals 72–73.1 of the NE module act directly on the pulse enable, terminal 63 at the monitoring module. If there is a line fault or a fault signal, then the ready signal is withdrawn at the NE module; this means that after the drop–out time of the ready relay, the pulses of the drives after the monitoring module are inhibited and these drives "coast down".

This interlock cannot be used, e.g. for a power failure concept – and also it can disadvantages with respect to other applications when compared to a delayed shutdown.

- Delayed shutdown pulse enable → refer to Fig. 8-6

Terminal 63 at the monitoring module is also only enabled via the ready/fault signal at the NE module. If the signal is withdrawn at the NE module, terminal 63 is however only inhibited via time relay–KT with drop–out delay.

This means, for example, for a line fault or a fault signal at the NE module, under certain secondary conditions, the drives can be even more quickly braked:

- When braking, the DC link voltage must remain within the minimum and maximum monitoring limits (refer to Chapter 6.3).
- The external +24V power supply must maintain the enable signals of terminals 65, 663.
- For 611 digital drive modules, the internal enable signals must be maintained via the digital drive bus of the SINUMERIK 840D, 810D or for SIMODRIVE 611 universal, communications must be kept via PROFIBUS DP.

**Addresses**

Contact addresses for the fuse terminals used in connection examples in Section 8.3.1.

PHOENIX KONTACT GmbH & Co.  
 Flachsmarktstrasse 8  
 32825 Blomberg, Germany  
 Tel. +49 (0)5235/30 0  
 Fax +49 (0)5235/341200

SIBA Sicherungen–Bau GmbH  
 Borker Strasse 22  
 44532 Luene, Germany  
 Tel. +49 (0)2306/7001–0  
 Fax +49 (0)2306/7001–10

## 8.4 Drive modules

### 8.4.1 611 feed module with High Performance/High Standard

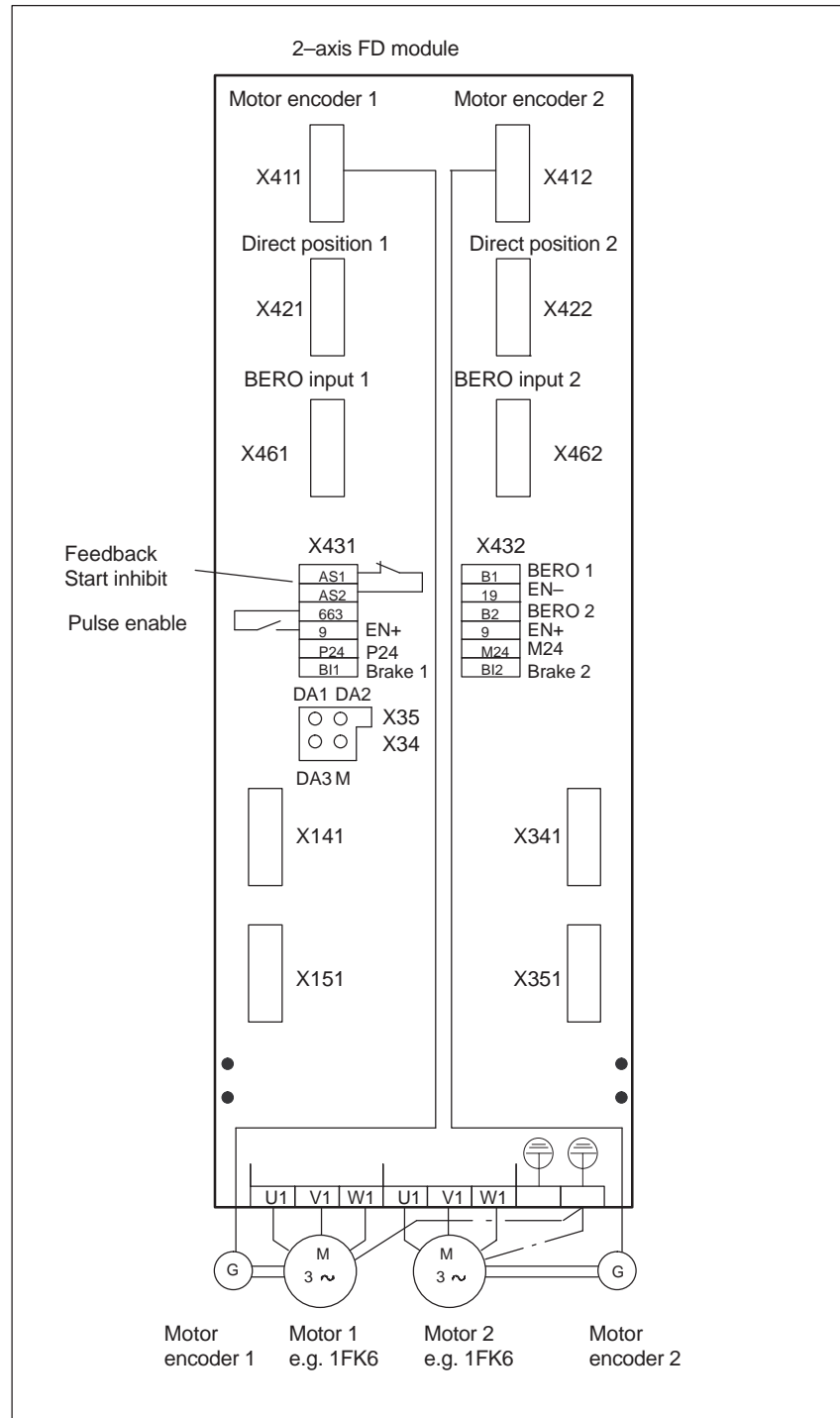

Fig. 8-7 Diagram showing the terminals of the VSA module with High Performance/High Standard

## 8.4.2 Description of the interfaces and functions

The diagram of the terminals in Fig. 8-7 shows, in a simplified form, a 2-axis 611 feed module – comprising power module, control unit with High Performance/High Standard.



### Reader's note

Control unit with digital and PROFIBUS DP interface  
—> refer to Chapter 4.

### Terminals AS1, AS2

Signaling contact, relay, start inhibit

When connecting contacts AS1/AS2 in series, a contact voltage drop up to max. 0.2 V must be taken into account for the lifetime of the contacts (100000 switching operations). For a 24 V switching voltage, due to the non-linear contact characteristics, from experience, five contacts can be simply connected in series without encountering any problems.

### Terminal 663

Pulse enable/start inhibit

When terminal 663 is energized, this initiates two functions:

- The pulse enable and inhibit are effective via an optocoupler input after 1 ms for a specific axis or for 2-axis modules, for a specific module.
- The start inhibit, terminal 663 open-circuit, acts with a delay of approx. 40 ms after terminal 663 is inhibited due to the drop-out delay of the start inhibit relay.

The start inhibit supports safety-relevant functions, refer to Section 8.5.

For pulse inhibit/start inhibit, the drives "coast down" without being braked.

Switch on terminal 663 after the ready signal of the power supply (terminals 72 to 74); when stopping after a power failure, terminal 663 must remain driven by means of the voltage backup until the motors have reached a standstill.

Further, the 611D 1-axis and 2-axis modules and 611 universal HRS with PROFIBUS interface also have a pulse enable signal that acts on specific axes. The control is realized through NC/PLC interface signals via the digital drive bus or via the PROFIBUS DP interface. The signals are effective, delayed corresponding to the appropriate cycle times.

### Terminal 9

FR+

+24 V enable voltage for the internal enable signals.

The terminal may only be used to enable the associated drive group.

### Terminal 19

FR-

0 V enable voltage for the internal enable signals.

**P24 terminals** +24 V supply for the brake control, tolerance range +18...30 V

**M24 terminals** 0 V supply for the brake control

**Terminals BE1, BE2** Output, brake control axis 1 and axis 2, max. current is 500 mA

A UL–certified miniature fuse (max. 3.15 A) must be provided at the supply for the brake control:

Value: e.g. 3.15 AT/250 V; 5x20 mm UL

Company: Wickmann–Werke GmbH

Annenstrasse 113

58453 Witte, Germany

Order No.: 181



#### Reader's note

Connection example for a holding brake, refer to Chapter 4.1.1.

**Terminals B1, B2** Input, external zero mark (BERO), axis 1 and axis 2.

Rated operating voltage: +13 to 30 V

If the referencing of the encoder zero pulses cannot be evaluated, then a signal supplied from a mounted sensor (BERO) can be fed via this input as an "equivalent zero mark".

#### DAC assignment

Three 8–bit digital/analog converter (DAC) channels are available. An analog image of various drive signals can be connected through to a test socket via these converters.

The three DAC channels are assigned the following drive signals by default:

DA1: Current setpoint                      Default shift factor: 4

DA2: Speed setpoint                        Default shift factor: 6

DA3: Actual speed                         Default shift factor: 6

M: Reference point (ground)

Resolution: 8 bits

Rated operating voltage: 0...5 V

Maximum current: 3 mA

## 8.5 Start inhibit in the drive modules/safe standstill

### 8.5.1 Start inhibit applications

The SIMODRIVE 611 drive control units support the "safe standstill" function – this provides protection against unexpected starting according to the requirements of Appendix I No. 1.2.7 of the Machinery Directive 98/37/EC, DIN EN 954–1 Category 3 and DIN EN 1037. It is important that the information and the instructions in this documentation are precisely adhered to.

For this purpose, the drive control units are provided by default with an internal safety relay with forced contacts. In the Configuration Manuals and user manuals, this safety relay is called a "start inhibit" function or "start inhibit relay."

This safety relay galvanically separates the power supply of the optocouplers for pulse transmission to the IGBT. The connected motor can no longer generate torque.

The "safe standstill" function prevents unexpected starting of the motor (from standstill) that is connected to the drive control unit. The motor shaft is in a no-torque condition when the "safe standstill" function is active. This is the reason that this safety function should only be activated after the drive actually comes to a standstill. Otherwise, it will not be able to brake. The external machine control must have first brought the machine to a standstill and ensured that this has actually taken place (that the machine has come to a standstill).

---

#### Caution

The velocity should be zero prior to the "safe standstill" function.

---

---

#### Notice

When the start inhibit function is correctly used, the forced signaling contact AS1/AS2 must always be included in the line contactor circuit or the EMERGENCY STOP circuit. If the function of the start inhibit relay is not plausible regarding the operating mode of the machine, then the drive involved must be electrically isolated from the line supply, e.g. using the line contactor in the infeed module. The start inhibit and the associated operating mode may only be re-used again after the fault has been removed.

---

### 8.5.2 Mode of operation of the start inhibit

The current through the individual motor windings is controlled using the inverter power module. The motors are fed with sinusoidal current.

A pulse generation logic clocks the six power transistors in a rotating field-orientated pattern. An optocoupler for potential isolation is connected in each transistor arm between the control logic and the control (gating) amplifier of the power module.

The start inhibit acts on each specific module. In each of the drive modules, a positively-driven relay in the inverter control acts in the input circuits of the optocouplers.

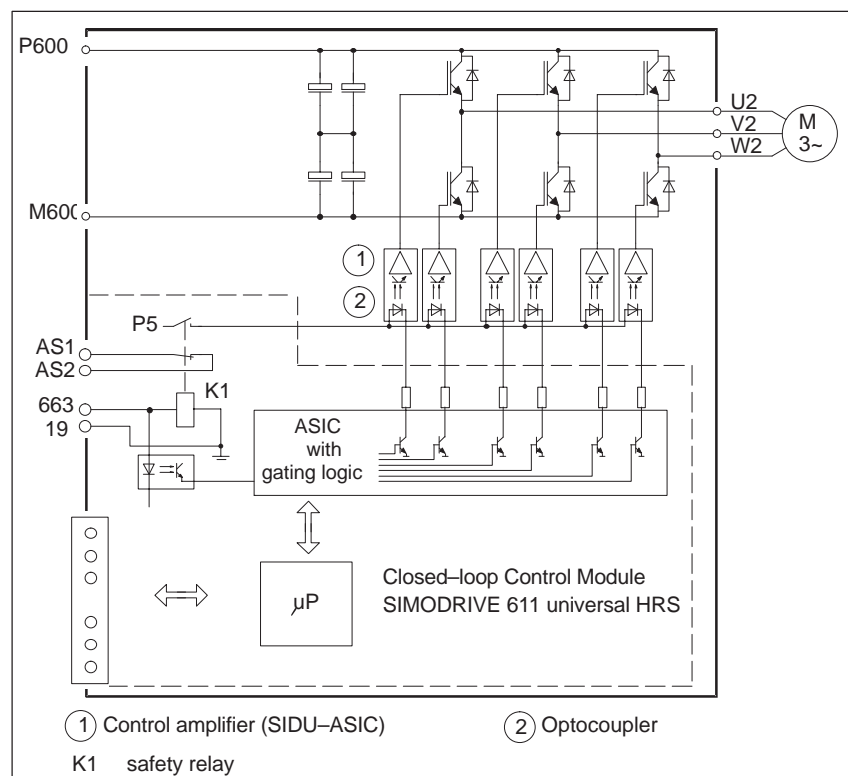

Fig. 8-8 Mode of operation using as an example the SIMODRIVE 611 universal HRS

A relay contact interrupts the power supply of the optocoupler inputs. This means that the optocoupler blocks and cannot transfer any signal. The pulse generation logic is inhibited using an additional branch that is electrically isolated.

For the drive modules, these two circuits are controlled from the machine control through terminal 663 (motor start inhibit). The state of the relay contact in the pulse power supply circuit is signaled to the external adaptation circuit through a positively opening contact.

The signaling contact is accessible at the module terminals AS1 and AS2 and the user can interlock this with his safety-relevant control. When the start inhibit fails, these start inhibit signaling contacts must disconnect the drive from the line supply via the power contactor in the line supply infeed (line contactor in the infeed module).

## 8.5 Start inhibit in the drive modules/safe standstill

When the start inhibit circuit is activated, it is no longer possible to gate several power transistors orientated to the rotating field.

**Warning**

In the case that two faults simultaneously occur in the power module, a residual risk remains where the drive suddenly rotates through a small angle:

- > FT motors: 4 pole 90°, 6 pole 60°, 8 pole 45°;
- > Induction motors: In the retentive area, max. 1 slot division, that corresponds to approx. 5° to 15°

When a fault occurs, 1FN linear motors can continue to rotate electrically through 180° (approx. 56 or 72 mm including overshoot).

**Warning**

When the start inhibit is active, the motor can no longer generate any torque. If external forces act on the drive axes, additional holding devices and equipment are required, e.g. brakes. Here, it is especially important to note the effect of gravity on hanging/suspended axes.

The start inhibit does not result in electrical isolation. This means that under no circumstances does it provide protection against "electric shock".

For operational interruptions, maintenance, servicing and cleaning work performed on the machine or plant, the complete machine must also be electrically isolated from the line supply using the line supply isolating device, e.g. main switch (see EN 60204–1; 5.3).

### 8.5.3 Connecting–up the start inhibit

The start inhibit is addressed in the drive modules via terminal 663. The start inhibit relay is controlled using the internal enable voltage FR+ (terminal 9, +24 V)/or an external +24 V voltage. When using an external voltage source, its reference potential (ground) must be connected to FR– (terminal 19).

When the relay is open, terminal 663 open, the start inhibit is activated. When the AS1/AS2 signaling contact is closed, this signals the "start inhibit is effective" state with electrical isolation.

The circuit must be protected against overload and short circuit using a fuse with a max. 2 A rating!

When terminal 663 is externally controlled (drive), a fail–safe signal must be used.

## 8.5 Start inhibit in the drive modules/safe standstill

**Notice**

The start inhibit relay has pick-up and drop-out delay times of max. 40 ms. The external wiring must be connected to terminals AS1/AS2 so that it is short-circuit proof.

One side of the excitation coil of the safety relay is connected to the grounded electronics chassis (PELV circuit according to DIN VDE 0160). When supplying the excitation coil (relay coil) from an external 24 V power supply, its negative pole must be connected to ground potential. The external 24 V power supply must fulfill the requirements for a PELV circuit in compliance with DIN VDE 0160.

Table 8-1 Technical data of the safety relay

Terminal	Designation	Description	Type <sup>1)</sup>	Section
AS1 <sup>2)</sup>	Contact 1	Feedback signal contact, relay	NC	30 V DC/max. 2 A
AS2 <sup>2)</sup>	Contact 2	Start inhibit		250 V AC/max. 1 A <sup>3)</sup>
663	Control input "start inhibit"	Nominal resistance of the excitation coil 600 Ω ... 1000 Ω	I	21 – 30 V DC Max. switching frequency: 6/min Electrical lifetime: min. 100.000 operating cycles Mechanical lifetime: 10 million operating cycles
9	Enable voltage FR+ (internal)		O	+ 24 V
19	Reference FR- (external)		O	Chassis ground

- 1) I = input; O = output; NC = NC contact
- 2) When the AS1/AS2 contacts are connected in series a contact resistance of approx. 0.20 Ohm must be taken into consideration over the lifetime of the contacts. For a 24 V switching voltage, due to the non-linear contact characteristics, from experience, five contacts can be simply connected in series without encountering any problems.
- 3) In accordance with EN 60204-1 (machine safety), control transformers must be used for AC control voltages.

**Warning**

Only qualified personnel may install and commission the "safe standstill" function.

All of the external safety-relevant cables, e.g. control cable for the safety relay, feedback signal contacts, must be routed so that they are protected, e.g. using cable ducts. The possibility of short-circuits and cross-circuits must be excluded.



### 8.5.4 Sequence and timing when using the start inhibit

The drives must have been stopped before terminal 663 is inhibited and the start inhibit is activated.

The drives can be stopped, e.g. by ramping down the drives in a controlled way using the NC program, inhibiting the drive–enable terminal 64 or the axis–specific controller enable, terminal 65.

Under fault conditions, the equipment must be safely disconnected and isolated from the line supply using the line contactor.

If a fault occurs when actuating the start inhibit, then this fault must be removed before the isolating mechanical protective devices (e.g. guards) to the working space of the machine or plant are opened. After the fault has been removed, the handling sequence for the start inhibit must be repeated. Under fault conditions, all of the drives, machine and the plant must be shutdown.

If one of the following faults occurs with terminal 663 de–energized and the protective devices withdrawn, then under all circumstances, EMERGENCY STOP must be immediately initiated:

- The feedback signaling contacts AS1/AS2 remain open; the start inhibit is not activated.
- There is a fault in the external control circuit itself.
- There is a fault in the signal cables of the feedback signal contact.

All of the drives of the machine/plant must be disconnected and isolated from the line supply via the line contactor.

If the control of the start inhibit has been correctly integrated in the external safety–relevant drive control – and has been carefully checked – the drives in the isolated working zone of the machine are secure against undesirable starting and personnel can enter or access the hazardous zone that has been restricted.

---

#### Notice

The relevant regulations for setting–up operation must be carefully observed.

---

### 8.5.5 Checking the start inhibit

The safety relay is an important component associated with the safety and availability of the machine. This is the reason that if the system functions incorrectly, the control unit together with the safety relay must be replaced. Function checks are required at regular intervals in order to detect an incorrect function.

The intervals specified in the appropriate regulation BGV A1 §39, Paragraph 3 are decisive for the intervals in which the system must be checked. This is the reason that the function check/test must be performed – depending on the application conditions; however, it must be performed at least once a year and in addition, after the system has been commissioned for the first time as well as when modifications and repairs have been made.

- The drive pulses must be inhibited when the voltage at terminal 663 is removed. Further, the feedback signal contacts AS1/AS2 of the start inhibit must close. The drive "coasts down".
- Withdrawing the protective devices, e.g. opening the protective door/guard while the drive is running. The drive must be braked as quickly as possible and then shut down. In so doing, no inadmissible hazard may occur.
- All of the possible fault/error cases that can occur must be individually simulated in the signal lines/cables between the feedback signal contacts and the external control as well as the signal evaluation functions of this control – for example, by interrupting the start inhibit monitoring circuit at terminal AS1–AS2.
- The monitoring circuit AS1 – AS2 should be disconnected for this purpose.

In all of the simulated fault situations, the line contactor must isolate all of the drives of the machine or system from the line supply.

If there is a connection between the NE or monitoring module power supply, terminal 500/M500 to the power DC link P600/M500, then this must be safely and reliably disconnected at the same time as the line contactor is opened, e.g. using contactors.



#### Warning

Only qualified personnel may perform these checks carefully observing the necessary safety measures.

After the start inhibit check has been completed, all of the changes made to the control as part of this check must be reversed.

8.5 Start inhibit in the drive modules/safe standstill

8.5.6 Example "safe standstill" with contactor safety combination

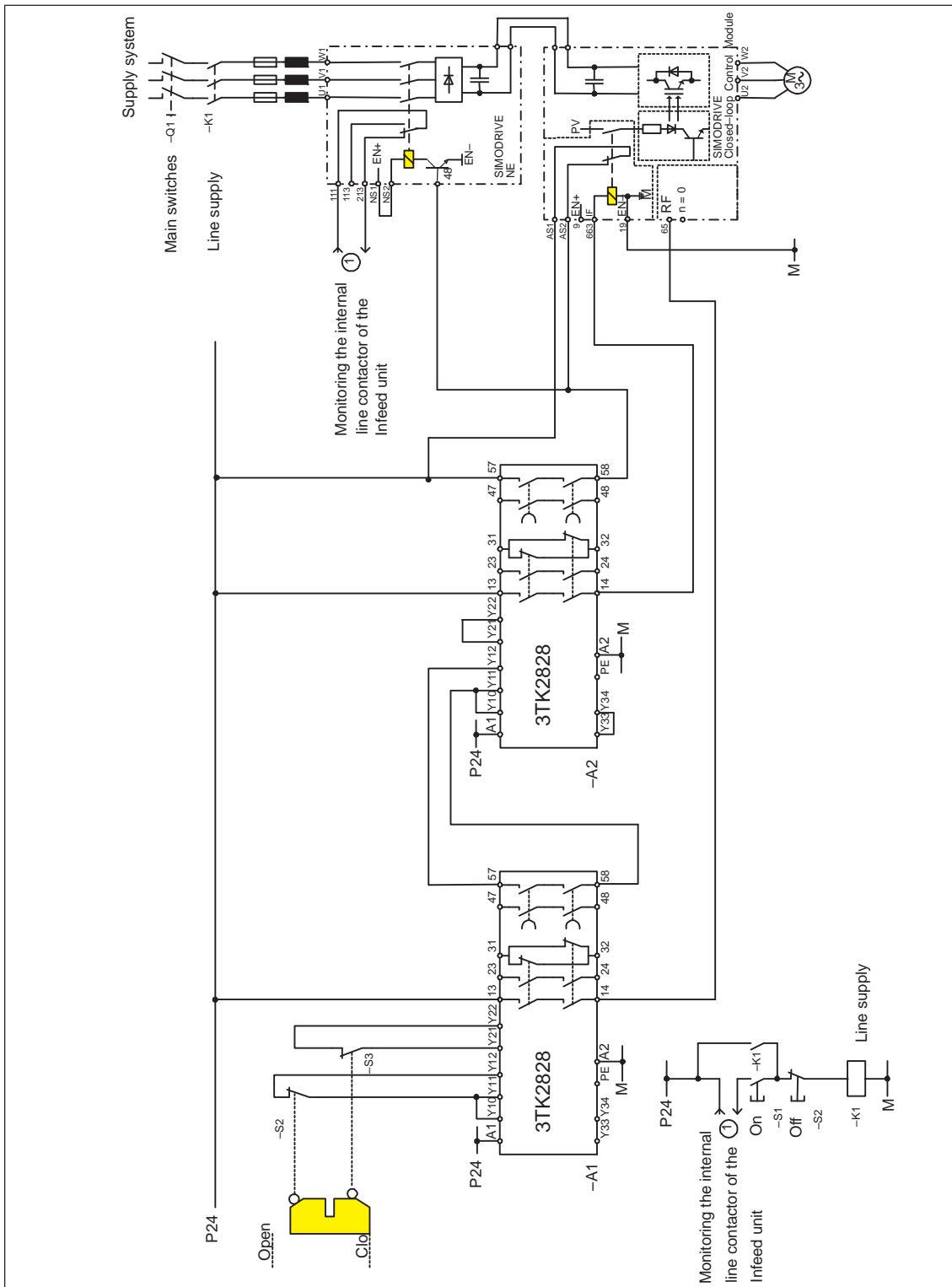

Fig. 8-9 Example, minimum circuitry for the "safe standstill" function with SIMODRIVE 611

## 8.5 Start inhibit in the drive modules/safe standstill

**Function**

Using two SIGUARD contactor safety combinations (A1, A2) for Emergency Stop and protective interlocking, it is possible to implement a configuration according to EN954–1 Control Category 3 and EN1037. Using the circuitry as shown in Fig. 8-9, a stop function, Category 1 according to EN 60204 is implemented.

Switches S2 and S3 are positively–opening position switches corresponding to EN 1088.

**Response to opened protective door**

When the protective doors are opened, the contactor safety combinations trip, staggered in time and initiate that the drive is stopped in accordance with EN 60204–1 stop Category 1.

- Signal 0 is specified at the controller enable (CE) input of the drive by means of the enable contacts of the contactor safety combination A1. The drive is immediately decelerated to speed 0, and the pulses are canceled.
- The delay time of the contactor safety combination A1 is set so that the drive has come to a standstill when the delayed contacts open therefore initiating the second contactor safety combination A2.
- The contactor safety combination A2 instantaneously de–energizes the safety relay in the drive via terminal 663. The feedback signal contacts of the safety relay must be closed after the selected delay time has expired, otherwise the drive is isolated from the line supply via terminal 48.
- For a protective door with tumbler mechanism, the drive is stopped with subsequent pulse cancellation, e.g. by pressing an appropriate button on the machine. The "zero speed" signal releases the tumbler mechanism and when the protective doors open, the safety relay in the drive is immediately de–energized. In this particular case, the first timer stage (contactor safety combination A1) is not required.
- When the line supply is switched–in through K1 with button S1 "power on" the correct functioning of the internal line contactor of the infeed unit is checked using the feedback signal in the power–on circuit.

## 8.5 Start inhibit in the drive modules/safe standstill

## 8.5.7 Example, "safe standstill" for several drive groups

## Function

The concept of the "safe standstill" function with higher-level main contactor as shown in Fig. 8-10 is implemented on an electrical injection molding machine.

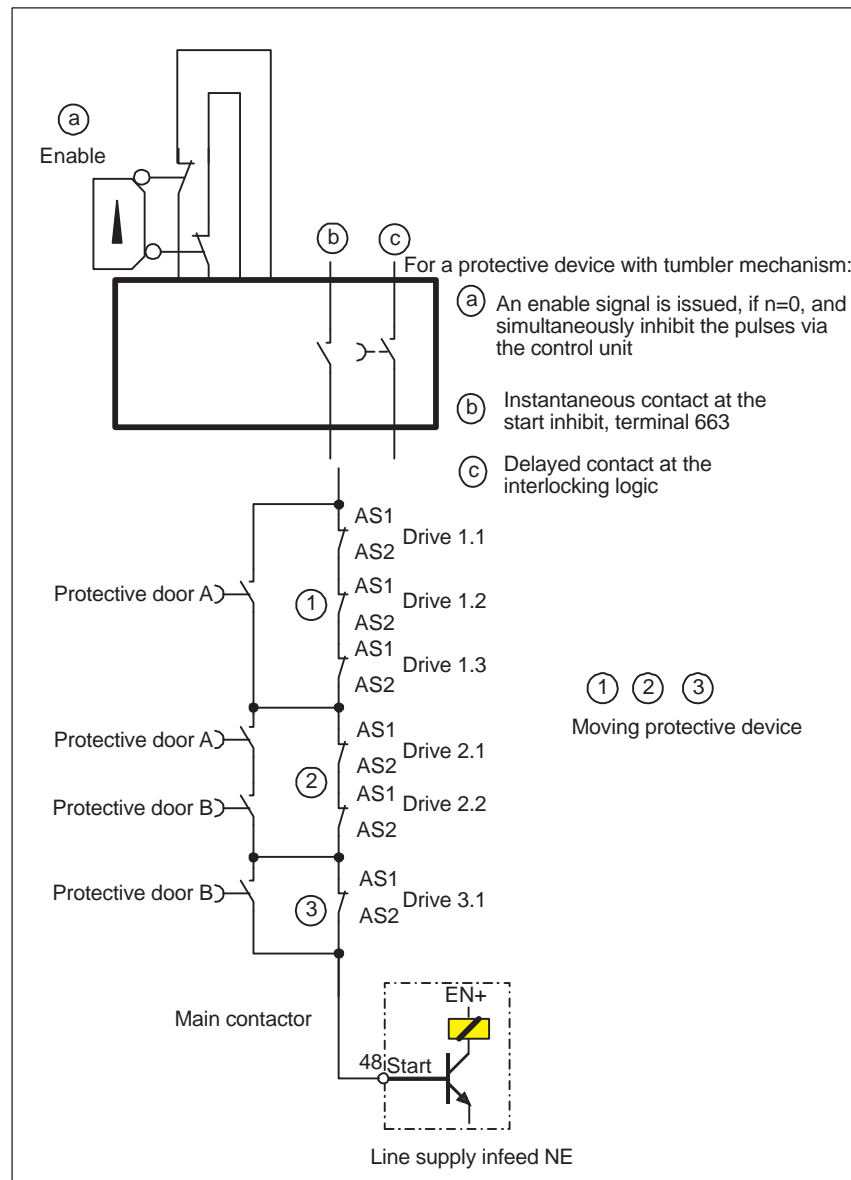

Fig. 8-10 Example, "safe standstill" function with several drive groups

The machine comprises three functional drive groups. The feedback signal contacts of each control unit AS1/AS2 within a drive group are connected in series. Every drive group is secured using a moving protective device. Interdependencies according to Table 8-2 apply between the drive groups and moving protective devices.

## 8.5 Start inhibit in the drive modules/safe standstill

Table 8-2 Effect of the moving protective devices on the drive groups

Moving protective device	Drive 1.1/1.2/1.3 ①	Drive 2.1/2.2 ②	Drive 3.1 ③
Protective door A	X	X	–
Protective door B	–	X	X
X = the drives are shutdown when the protective device is actuated			

**Behavior when the protective doors are open**

As long as the assigned protective device prevents any intervention in the hazardous zone, the feedback signal contacts of these power modules are jumpered. After the protective device has been opened, the drives must be shutdown in the defined time and the feedback signal contacts of the safety relay must be closed – otherwise, the higher-level main contactor will open.

## 8.6 Application examples with SIMODRIVE 611

### 8.6.1 Block diagram of the application example

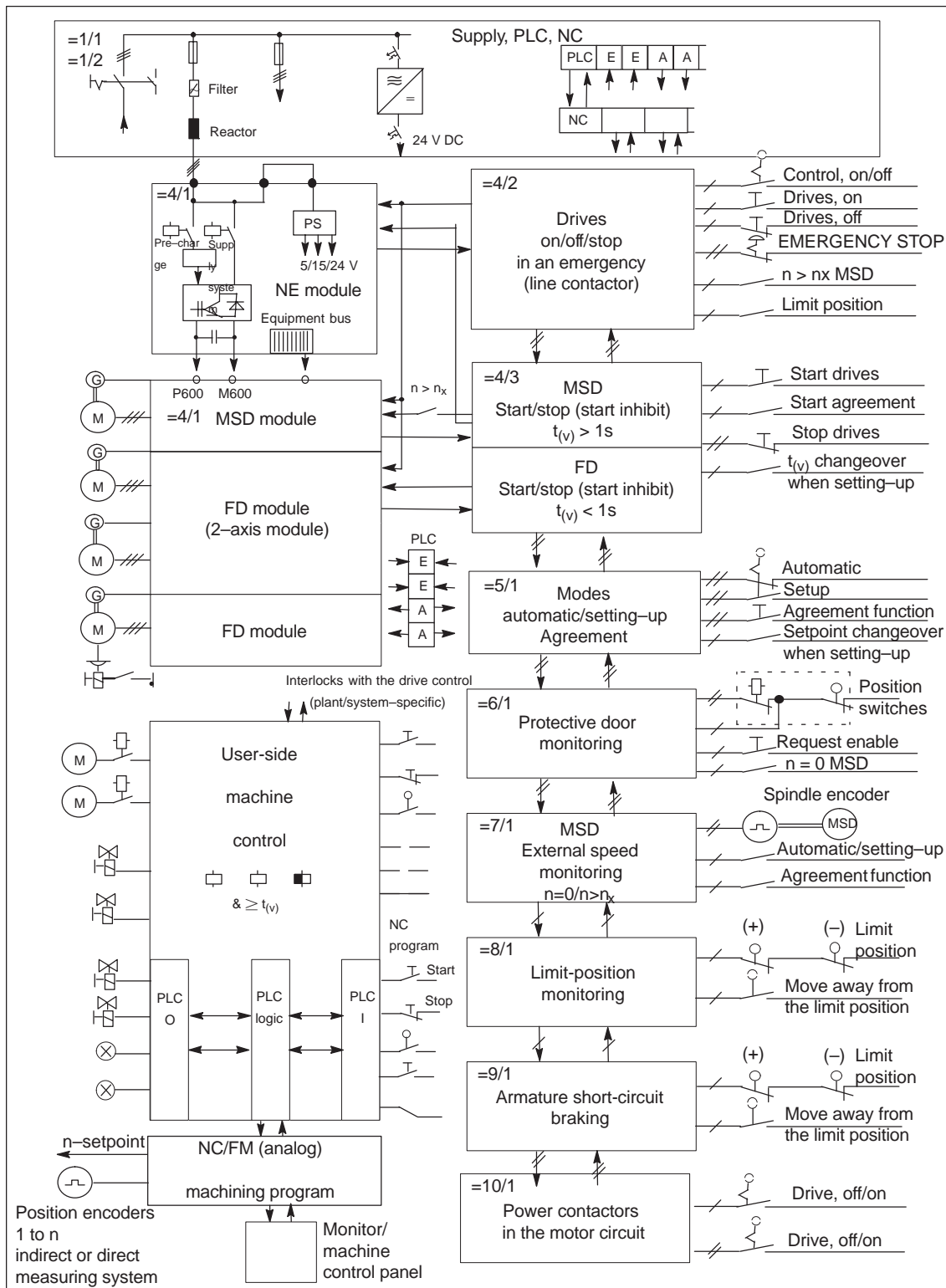

Fig. 8-11 Block diagram of the application example

## 8.6.2 Function description of the application example

### Application

The block diagram, Section 8.6.1 shows an overview of an application example for a complete drive-related control of a machine with SIMODRIVE 611 drive components with analog setpoint interface.

For information on versions with SIMODRIVE 611 digital and 611 universal, refer to Section 8.8.

The individual applications and functions of the drive control are described in detail in the following Section 8.7 using circuit examples =1 to =9.

The circuit examples =1 to =3 are provided for basic machine applications. Circuit examples =1 and =4 to =9 describe all of the essential functions that are used for a processing machine/machine tool.

The circuit concept has been designed so that the individual control groups, from the basic function in circuit example =4

- Drives on/off/stopping in an emergency situation; start/stop/safe standstill through additional functions
- Operating mode selection, automatic/setup mode with agreement =5
- Protective door monitoring with tumbler mechanism =6
- Limit switch, limit position monitoring =7
- Armature short-circuit braking =8, and
- Power contactors in motor circuit =9

can be used for the particular applications, graduated from basic up to complex functions. When expanding the control system, step-by-step, up to the fully expanded configuration, the terminal jumpers, in the circuit examples, should be removed (interrupted), and the required interlocking and monitoring circuits inserted.

In the application example, Fig. 8-11 the SIMODRIVE 611 drive group comprises a 1PH7 main spindle drive and three 1FT5 feed drives as an example for a machine tool.

The drive-related control essentially includes the safety-relevant, 2-channel hardware control with the associated PLC functions. The PLC control handles the coordinated sequence of the drive control through logic operations; however it does not handle any safety-relevant functions.

The NC/FM (positioning control), with the setpoint and actual value interface as well as the machine control of the user side, is not discussed in the subsequent text. This is the reason that they are only depicted from the essential principle.

- Control Category in accordance with EN 954-1

The 2-channel system structure of controls =4 to =6 corresponds, when the individual components are correctly used, to control Category 3 according to EN 954-1. This means that if a single fault occurs in the system, then the safety function must still be kept.



## 8.6 Application examples with SIMODRIVE 611

The user should evaluate the control Categories of the additional circuits =7 to =9. This depends on how he uses the third-party components/monitoring devices that he selected etc. and how they are integrated into the basic control in a safety-relevant fashion.

**Note**

For machines that are to be classified in a lower Category, e.g. 1 or 2 according to EN 954-1, after the hazard analysis/risk evaluation or type C Standard, the control can be principally derived from these circuit examples and implemented in a more simple, single-channel, system structure!

This also applies to the sub-areas/sub-functions of a machine that, for example, according to type C Standards, must be implemented with either a lower or higher control category, deviating from the basic machine. For example, after the danger analysis/risk evaluation it can also be necessary that a hydraulic/pneumatic clamping unit must be controlled in the work area using a two-handed control device in accordance with category 4.

**Functions**

- Switching examples =4 to =9

The 2-channel system structure is achieved in this application example:

First shutdown path: The power feed to the drive motors is disconnected via the start inhibit functions in the drive modules.

The shutdown is realized using terminal 663. The positively-driven feedback signal contact of the start inhibit relay via terminal AS1-AS2 is cyclically monitored and intervenes in the EMERGENCY STOP circuit of the safety relay.

For a detailed description of the start inhibit function, refer to Section 8.5.

Second shutdown path: The line contactor in the NE module galvanically disconnects the line supply from the DC link of the drive modules.

The shutdown is realized using terminal 48 at the same time (simultaneously) with the de-energizing of the contactor coil in a safety-relevant, electrically isolated fashion using terminals NS1- NS2.

The shutdown is realized, for example, when stopping in an emergency, from fault signals received from the drive system or via the start inhibit monitoring when a fault condition occurs.

After each power-off cycle, the forced normally closed contact 111 – 213 of the line contactor is monitored in the feedback circuit of the EMERGENCY STOP safety relay. For a detailed description of the line contactor, refer to Section 8.2.2.

For an EMERGENCY STOP, the drives are stopped in Stop Category 1 according to EN 60204-1; 9.2.2: "Controlled stopping" – the power feed is only interrupted when the motor has come to a standstill.

Circuit examples =2 and =3, shown in Section 8.7, can be used for basic and average applications.

- Circuit example =2:

When the drives are powered up and powered down, the complete drive group, including the line contactor and start inhibit terminals, is switched in a safety-related way through two channels. The power-on frequency per unit time of the NE module is limited. This is due to the pre-charging circuit to ramp up the DC link voltage at the capacitors.

This circuit is, for example, not suitable for machines where the protective door is frequently opened or for the "setting-up" mode where the agreement function is frequently applied.

- Circuit example =3:

Using this circuit, one or more drives can be selectively shut down in a safety-related way from an operational drive group, using a key-operated switch, limit switch, light barriers, and brought into the "safe standstill" operating mode.

Beforehand, the NC control must have safely stopped the drives. This circuit can also be used in conjunction with the basic control =4.

Circuit examples =2 and =3 are also used to obtain a basic understanding of the complex and extensive control functions from circuit =4 onwards.

---

**Note**

All of the following circuit examples neither include safety-related or other mechanical interlocks that may be necessary with the machine control on the user side.

---

### 8.6.3 Safety systems and Standards

<b>Objectives</b>	<p>The objective of safety systems is to keep potential hazards for both people and the environment as low as possible by using suitable technical equipment, without restricting, more than absolutely necessary, industrial production, the use of machines and the production of chemical products. The protection of man and environment has to be put on an equal footing in all countries by applying rules and regulations that have been internationally harmonized. At the same time, this is also intended to avoid that safety requirements in different countries have an impact on the competitive situation, i.e. the intention is to facilitate international trade.</p>
<b>Basic principle of the legal requirements in Europe</b>	<p>Legislation demands, "the quality of the environment and the health of people are to be protected using preventive measures" (Directive 96/82/EC of the Council "Seveso II"). Legislation also promotes "health and safety at work" (Machinery Directive, health and safety legislation). The objective to achieve these and similar goals is specified in the appropriate EU Directives by legislative bodies for various areas ("regulated area"). In order to achieve these objectives, the legislative bodies place demands on companies operating plants and systems and the manufacturers of equipment and machines. These legislative bodies have at the same time allocated responsibility for possible damage.</p>
<b>EU Directives</b>	<p>A new concept ("new approach", "global approach") used as basis for the EU Directives:</p> <ul style="list-style-type: none"><li>• EU Directives only specify generally valid safety goals and define basic safety requirements.</li><li>• EU Directives specify that the Member States must mutually recognize domestic regulations.</li></ul> <p>The EU Directives are all of equal importance, i.e. if several Directives are applicable for a specific piece of equipment or machine, then the requirements of all of the relevant Directives apply.</p> <p>For a machine with electrical equipment, among others, the following apply</p> <ul style="list-style-type: none"><li>• Machinery Directive 98/37/EC</li><li>• Low Voltage Directive 2006/95/EC</li><li>• EMC Directive 2004/108/EC</li></ul>
<b>Machinery directive</b>	<p>The European Machinery Directive is essential valid for all machines. The minimum requirements are defined in Appendix I of the Directive. More detailed information is then provided in the harmonized European Standards – types A, B and C.</p>
<b>Disposal</b>	<p>The devices must be disposed off corresponding to the regulations valid in the particular country!</p>

However, Standards have not been drawn-up for all types of machines. For machine tools for metal working, robots, and automated manufacturing systems, some Draft Standards and final Standards do exist, e.g. type C Standards. In many cases, Category 3 acc. to EN 954-1 is defined in these Standards for the safety-related controls. The basic requirement of this category is: "Single-fault fail-safety with partial fault recognition". Generally, this requirement can be fulfilled using a 2-channel system structure (redundancy). Sub-areas of a machine control can also be classified with other Categories – B, 1, 2, or 4 according to EN 954-1.

### **Hazard analysis and risk assessment**

According to the Machinery Directive 98/37/EC, the manufacturer of a machine or a safety component or the person or persons responsible for placing such equipment on the market is legally obliged to perform a risk analysis in order to determine all of the risks that may arise in connection with the machine or safety component concerned. He must design and construct the machine or safety component on the basis of this analysis.

A risk assessment must identify all residual risks that need to be documented. For the technique to evaluate and assess these risks, among others, the following Standards should be carefully observed EN 292 "General Design Guidelines for the Safety of Machinery"; EN 1050 "Safety of Machinery, Guidelines for Risk Assessment" and EN 954 "Safety-relevant Parts of Controls".

### **CE conformity**

The machinery manufacturer or the company based in the European Economic Community or persons that they have nominated must make a legal declaration regarding the CE Conformance for the complete machine.

---

#### **Note**

The listed Directives and legislation represent just a selection to communicate the essential goals and principles. This list does not claim to be complete.

---

## 8.7 Circuit examples =1 to =9 with SIMODRIVE 611

Fig. 8-12 = 1 cabinet supply, PLC, NC; Sheet 1/1 .....	8-269
Fig. 8-13 = 2 On/off/stopping in an emergency; Sheet 1/2 .....	8-270
Fig. 8-14 = 2 On/off/stopping in an emergency; Sheet 2/2 .....	8-271
Fig. 8-15 = 3 Start/stop/safe standstill; Sheet 1/1 .....	8-272
Fig. 8-16 = 4 On/off//stopping in an emergency; start/stop/safe standstill; Sheet 1/2 .....	8-273
Fig. 8-17 = 4 On/off//stopping in an emergency; start/stop/safe standstill; Sheet 2/2 .....	8-274
Fig. 8-18 = 5 Operating modes, automatic/setup mode with agreement; Sheet 1/1 .....	8-275
Fig. 8-19 = 6 Automatic operation with protective door monitoring; Sheet 1/1 .	8-276
Fig. 8-20 = 7 Limit switch, limit position monitoring; Sheet 1/1 .....	8-277
Fig. 8-21 = 8 Armature short-circuit braking; Sheet 1/1 .....	8-278
Fig. 8-22 = 9 Power contactors in the motor circuit; Sheet 1/1 .....	8-279

8.7 Circuit examples =1 to =9 with SIMODRIVE 611

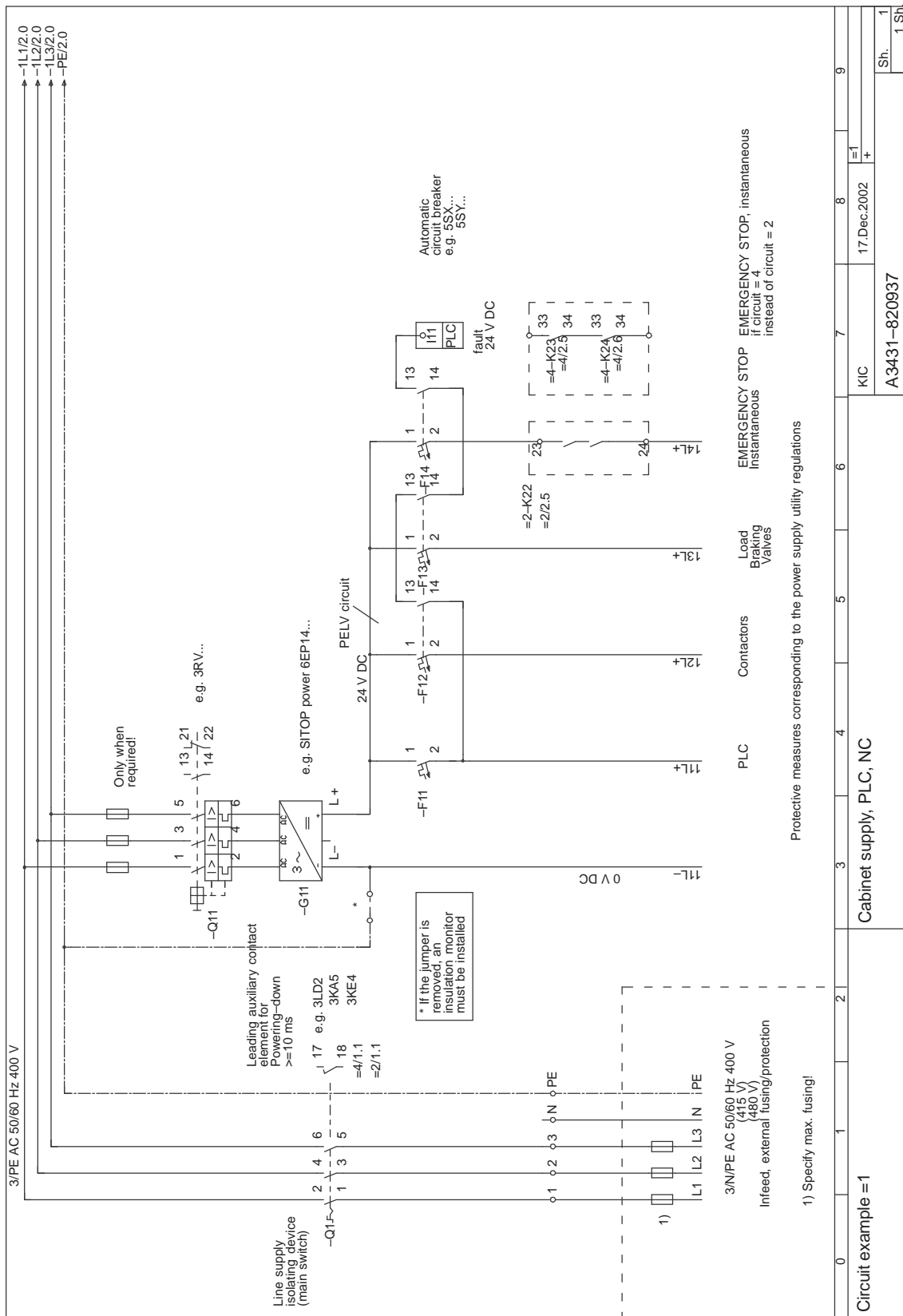

Fig. 8-12 =1 cabinet supply, PLC, NC; Sheet 1/1

8.7 Circuit examples =1 to =9 with SIMODRIVE 611

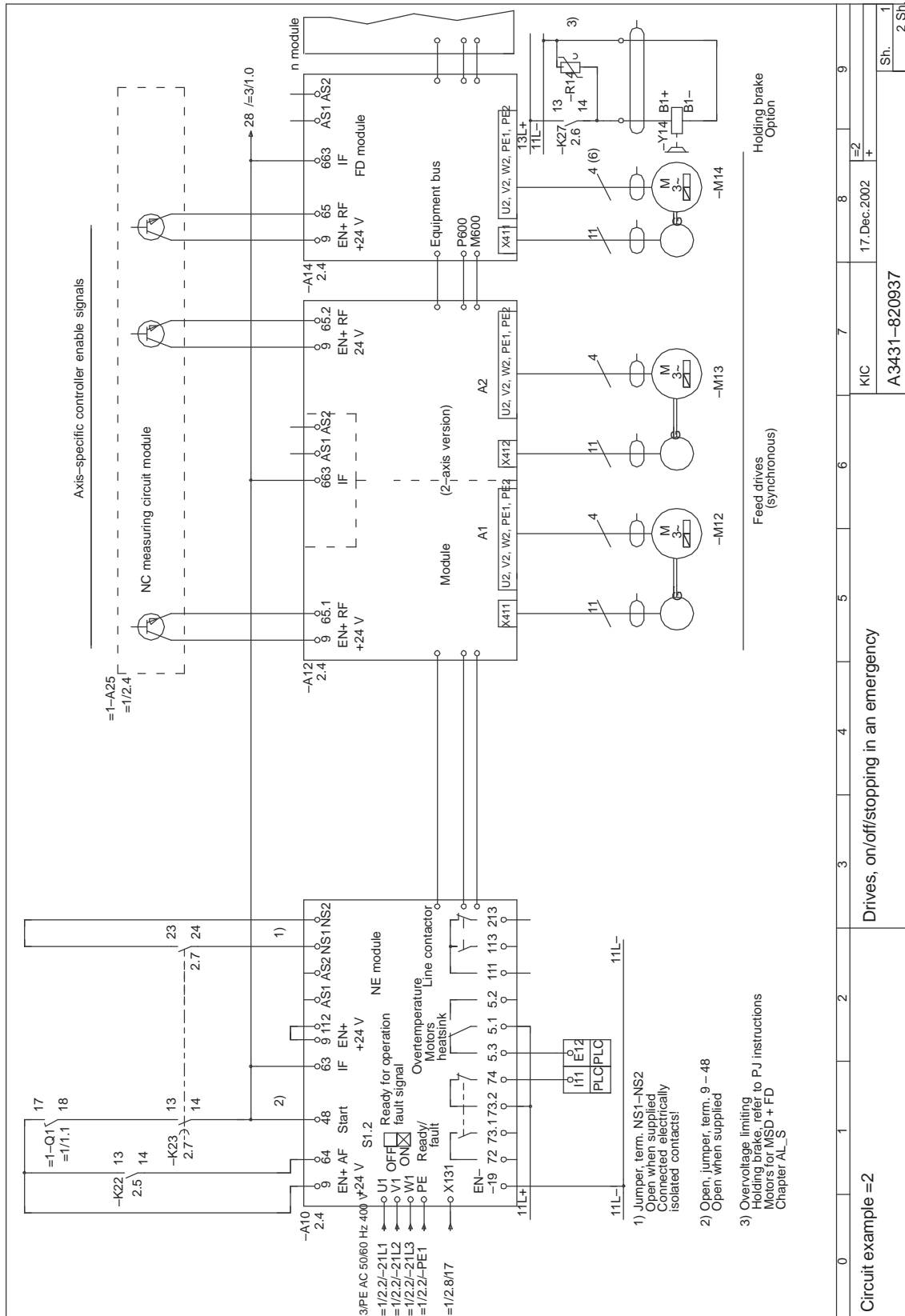
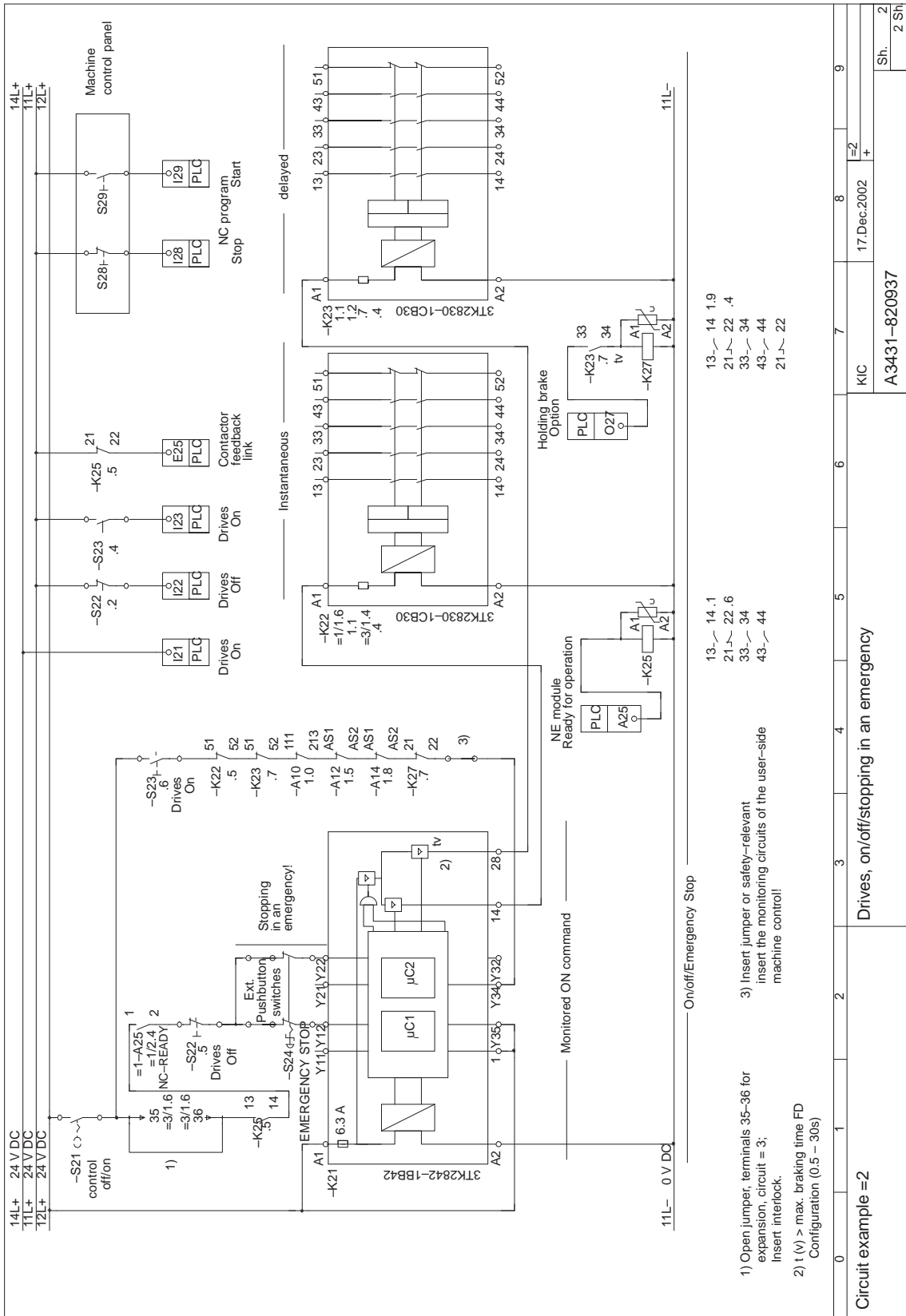

Fig. 8-13 =2 On/off/stopping in an emergency; Sheet 1/2

8.7 Circuit examples =1 to =9 with SIMODRIVE 611



- 1) Open jumper, terminals 35-36 for expansion, circuit = 3; Insert interlock.
- 2) t (v) > max. braking time FD Configuration (0.5 - 30s)
- 3) Insert jumper or safety-relevant insert the monitoring circuits of the user-side machine control!

Fig. 8-14 =2 On/off/stopping in an emergency; Sheet 2/2



8.7 Circuit examples =1 to =9 with SIMODRIVE 611

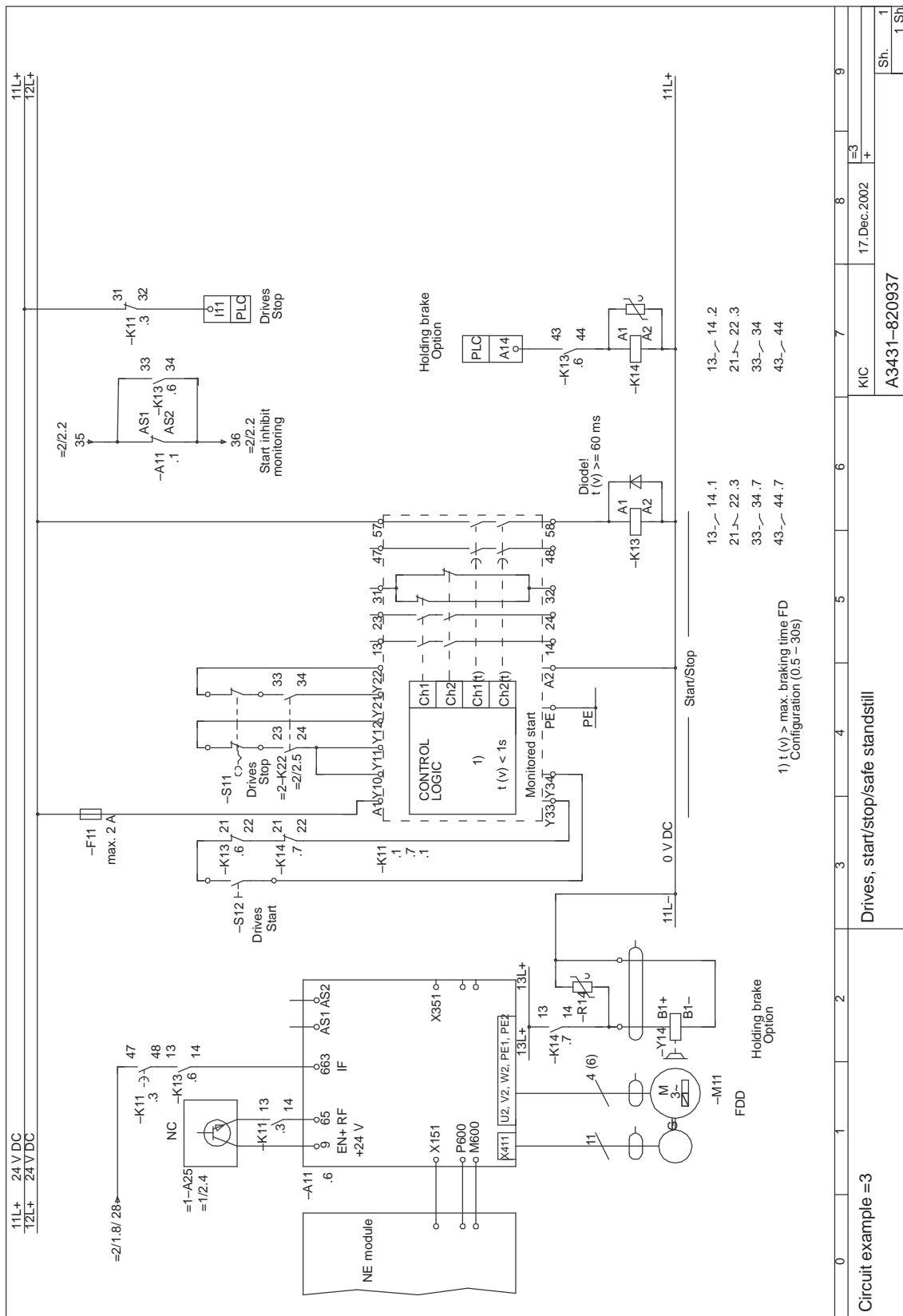

Fig. 8-15 =3 Start/stop/safe standstill; Sheet 1/1

8.7 Circuit examples =1 to =9 with SIMODRIVE 611

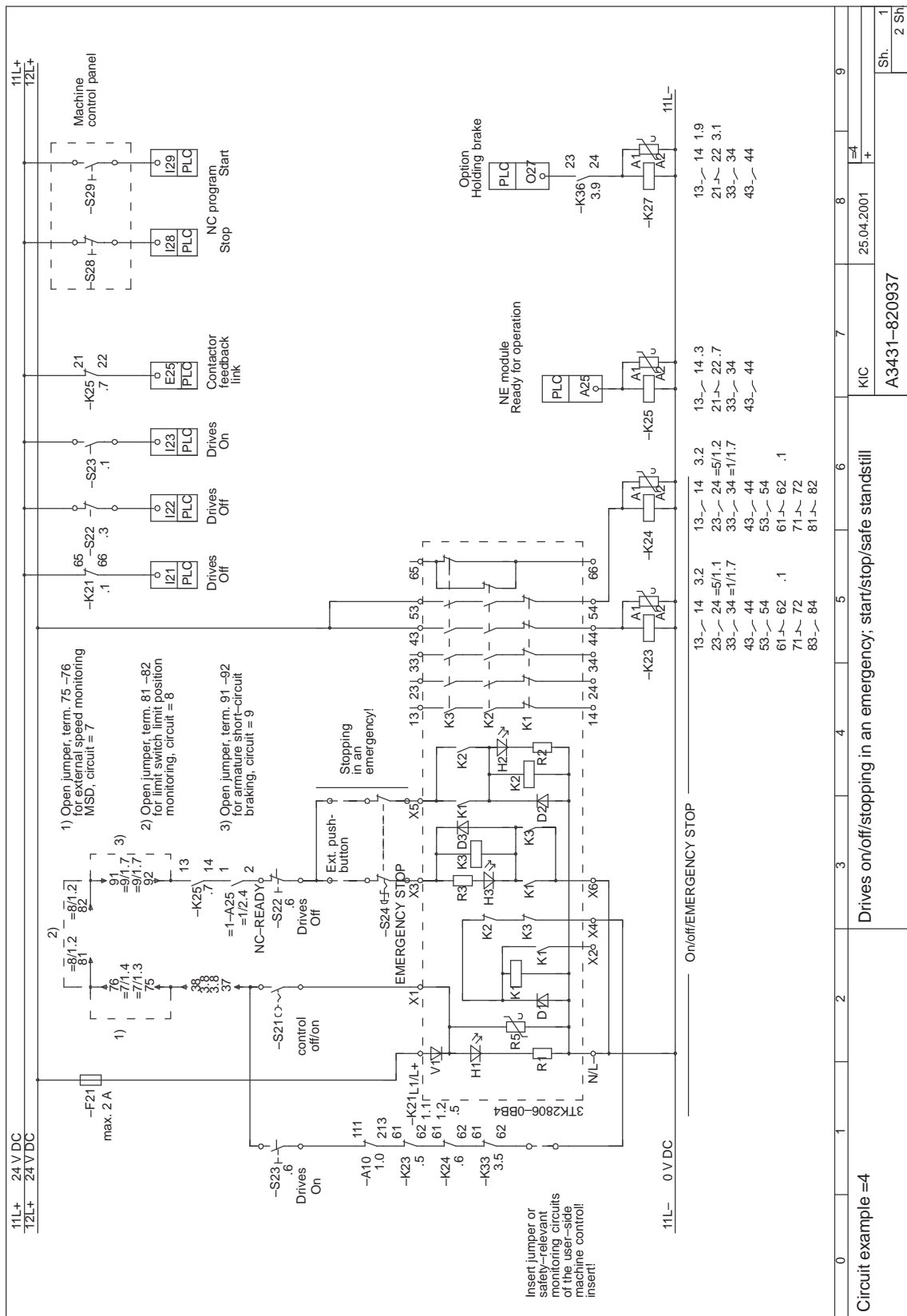

Fig. 8-16 =4 On/off/stopping in an emergency; start/stop/safe standstill; Sheet 1/2

8.7 Circuit examples =1 to =9 with SIMODRIVE 611

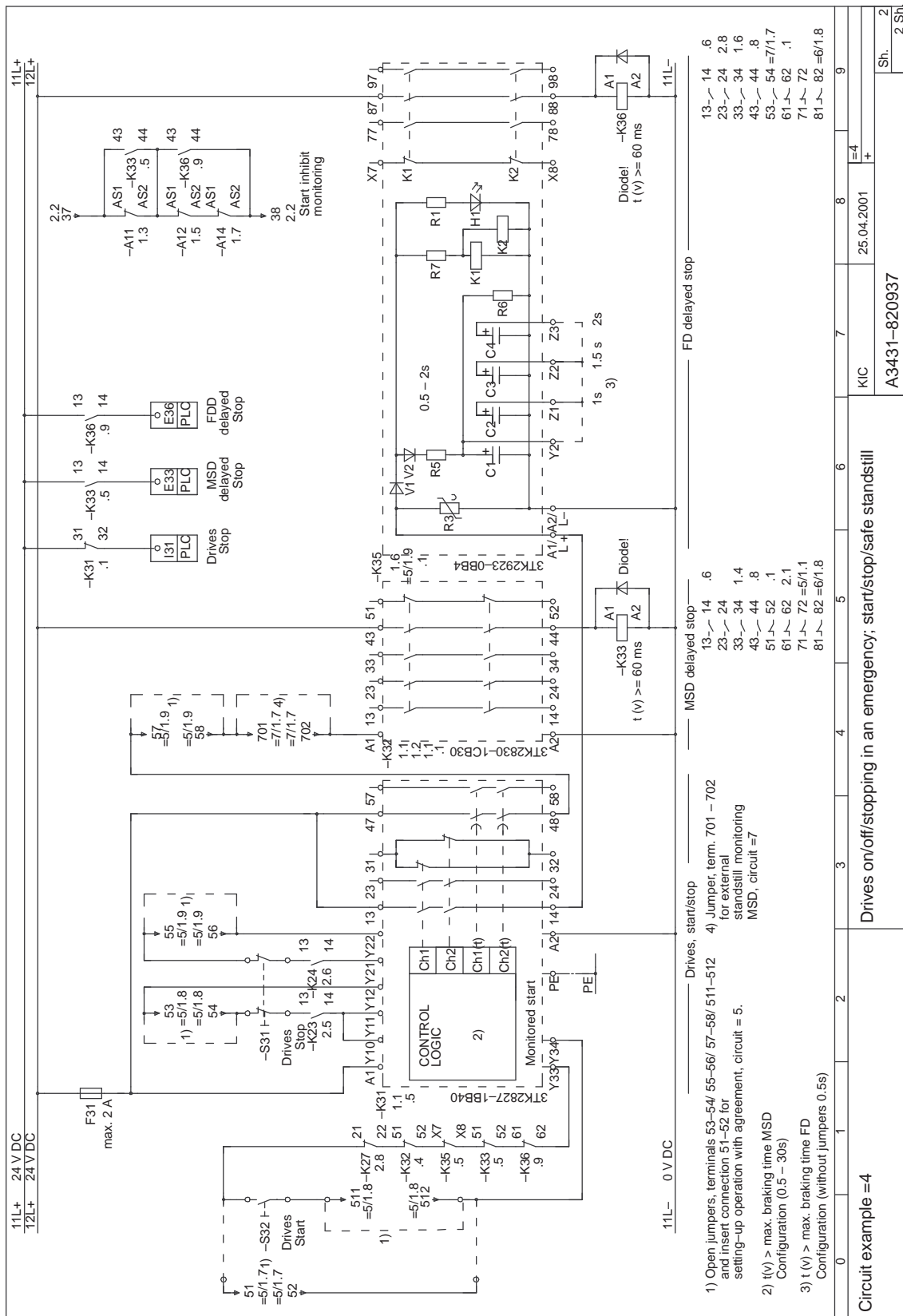

Fig. 8-17 =4 On/off//stopping in an emergency; start/stop/safe standstill; Sheet 2/2

8.7 Circuit examples =1 to =9 with SIMODRIVE 611

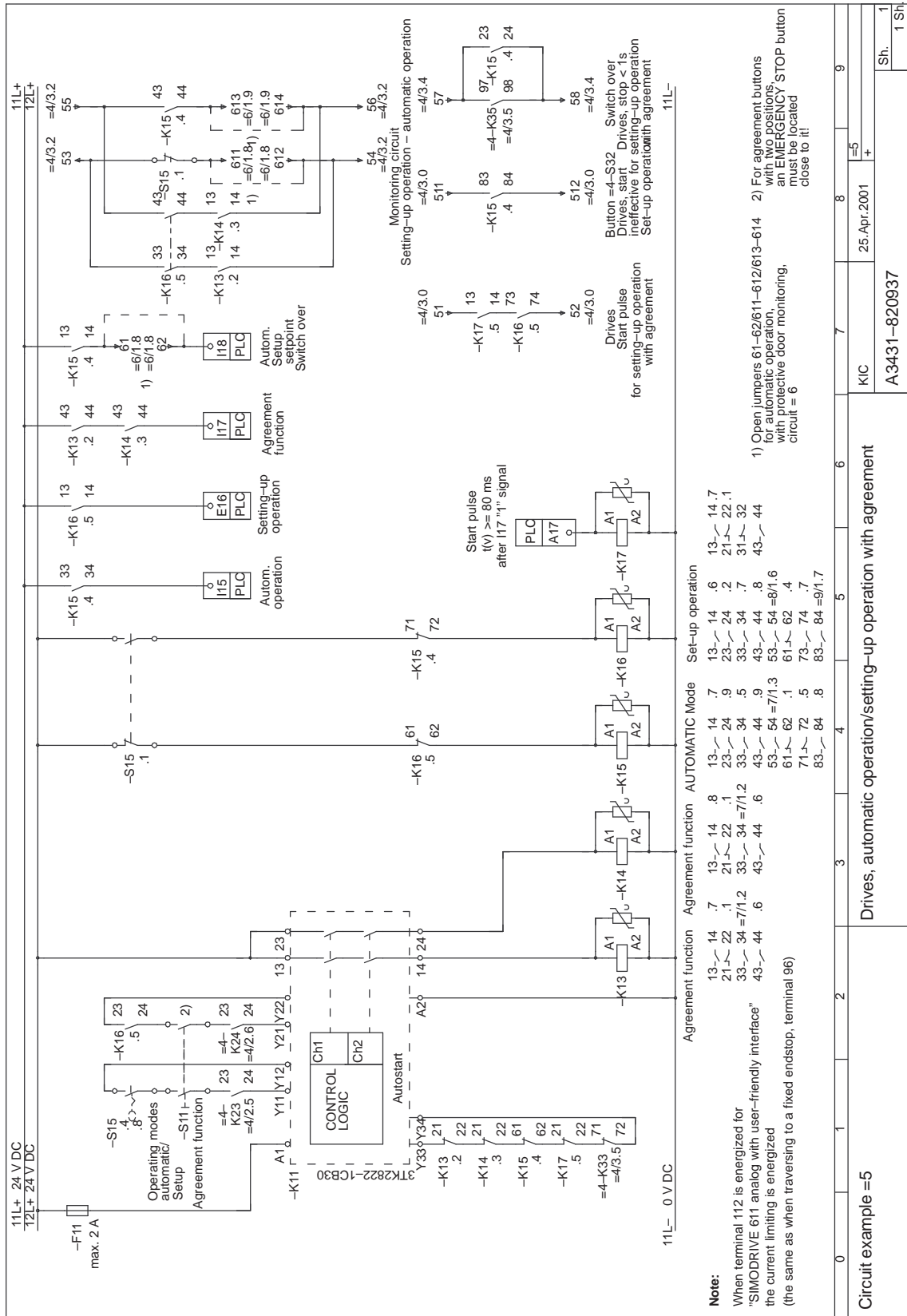

Fig. 8-18 =5 Operating modes, automatic/setup mode with agreement; Sheet 1/1

8.7 Circuit examples =1 to =9 with SIMODRIVE 611

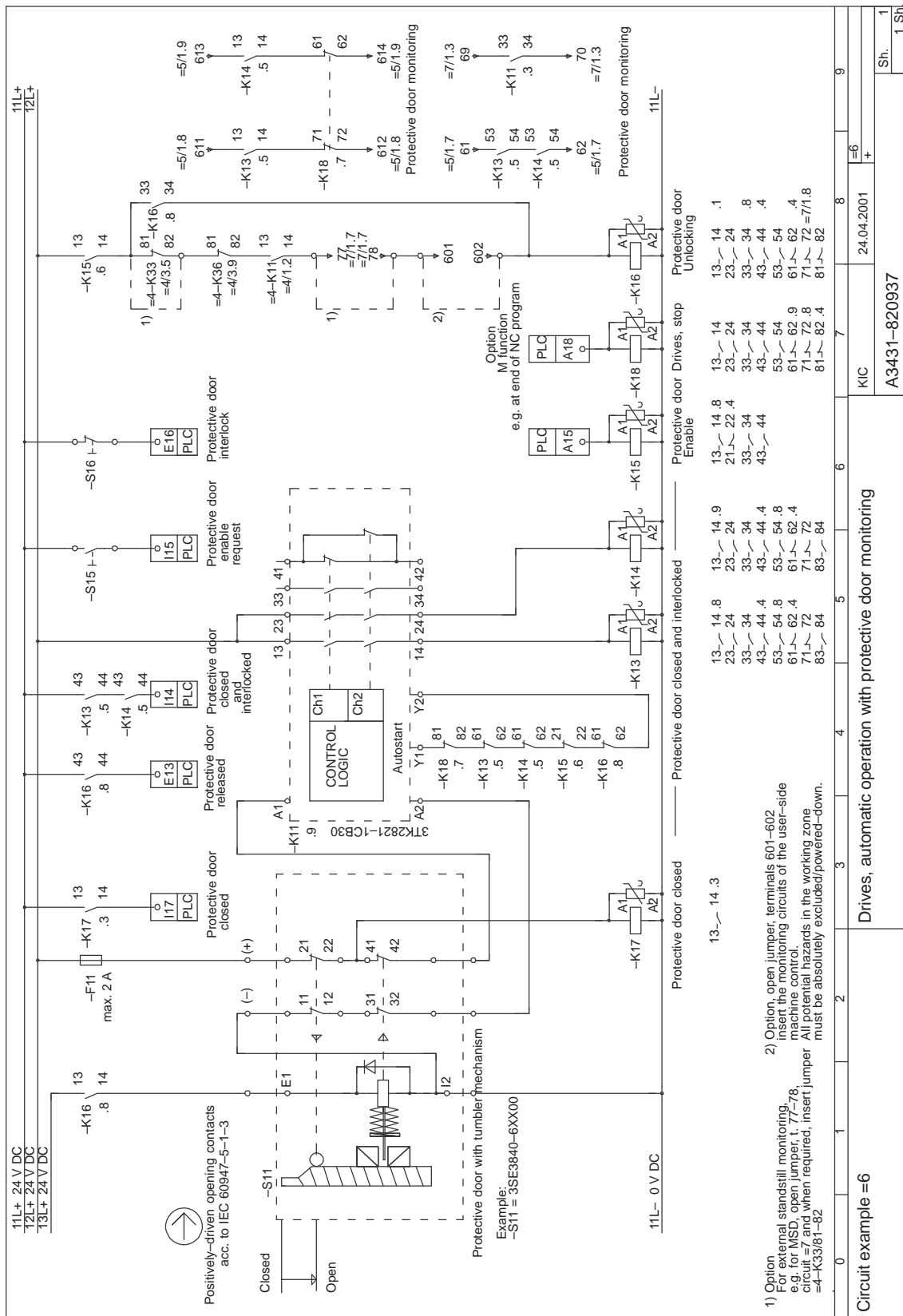

Fig. 8-19 =6 Automatic operation with protective door monitoring; Sheet 1/1

8.7 Circuit examples =1 to =9 with SIMODRIVE 611

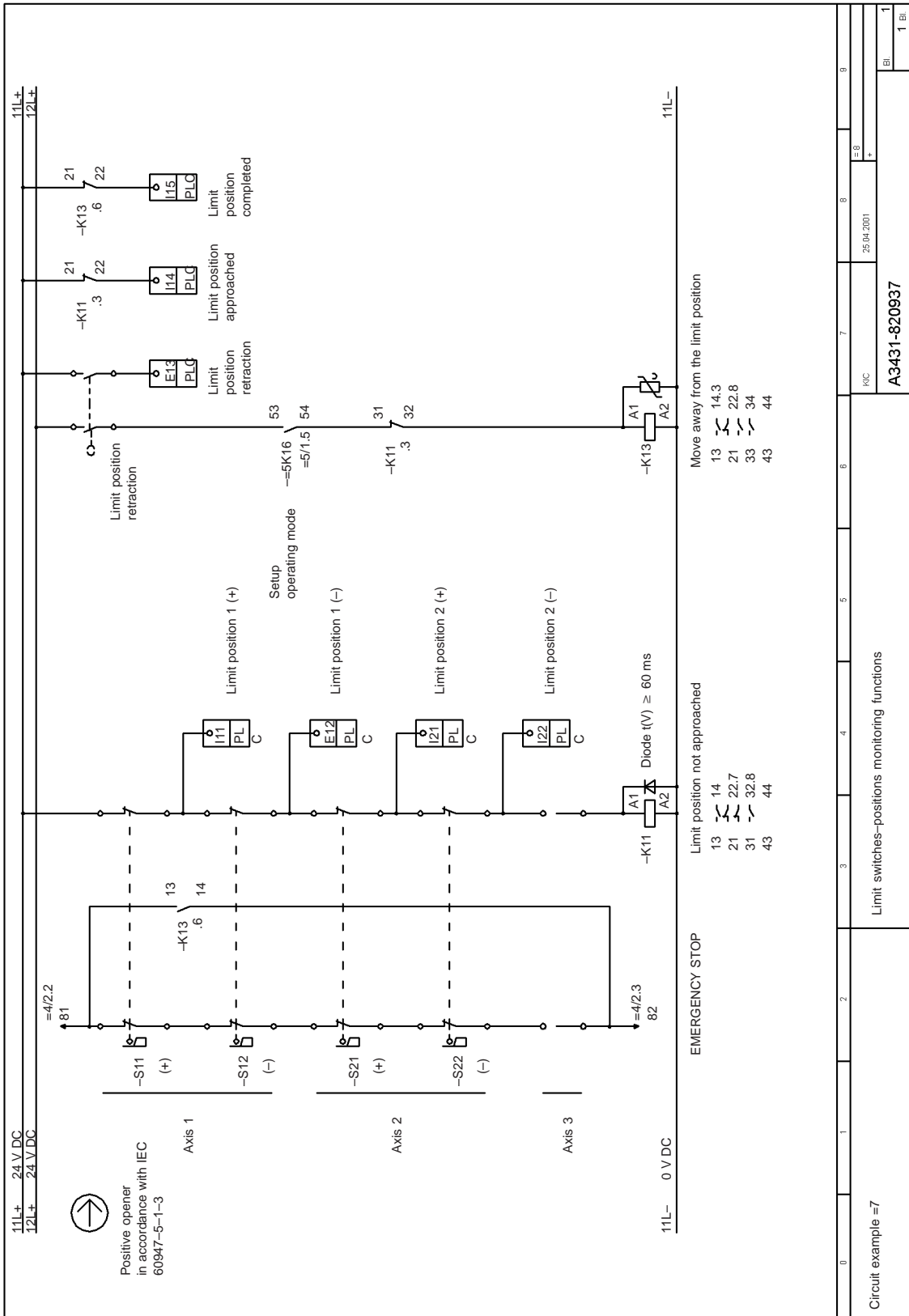

Fig. 8-20 =7 Limit switch, limit position monitoring; Sheet 1/1

8.7 Circuit examples =1 to =9 with SIMODRIVE 611

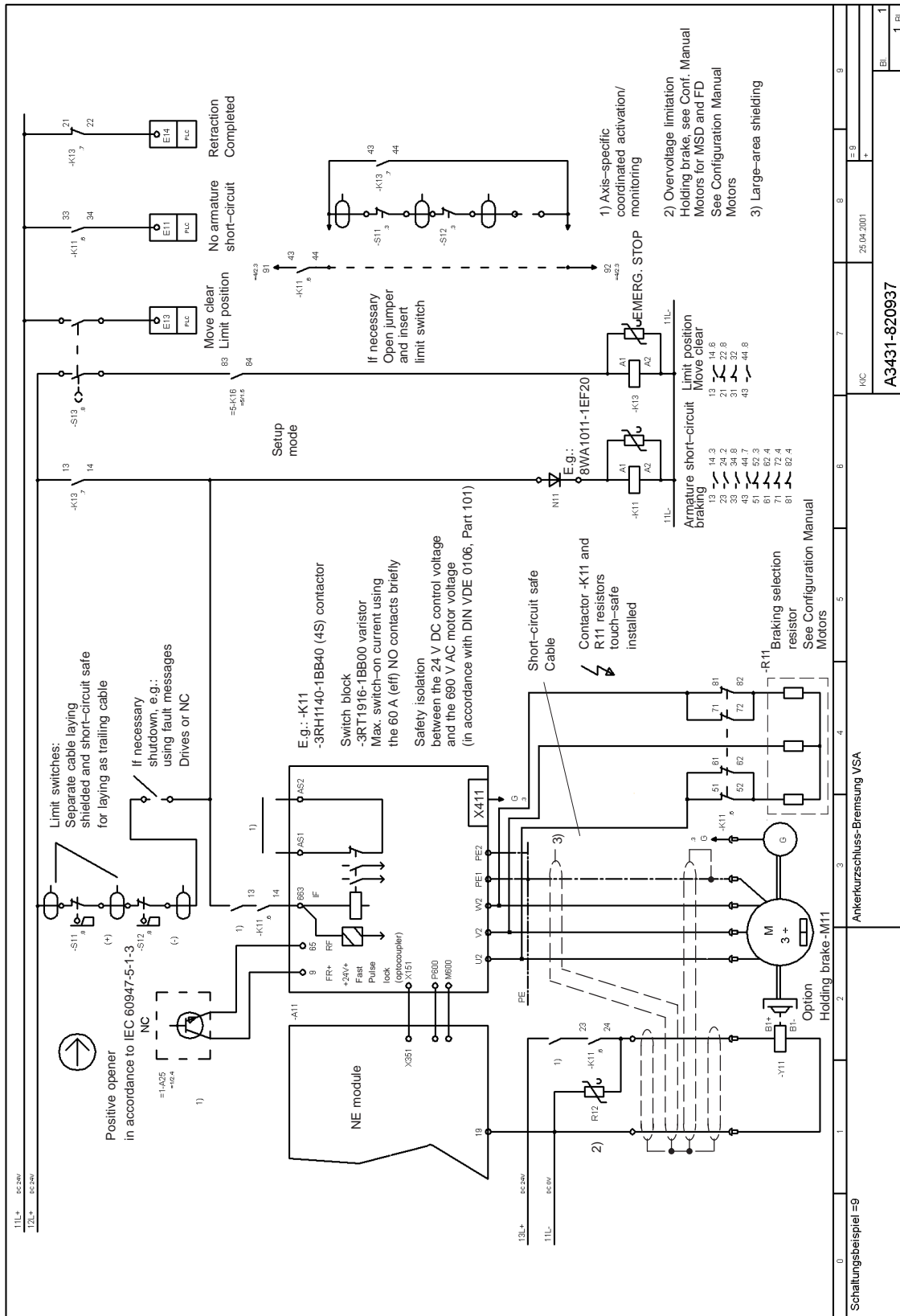

Fig. 8-21 =8 Armature short-circuit braking; Sheet 1/1

8.7 Circuit examples =1 to =9 with SIMODRIVE 611

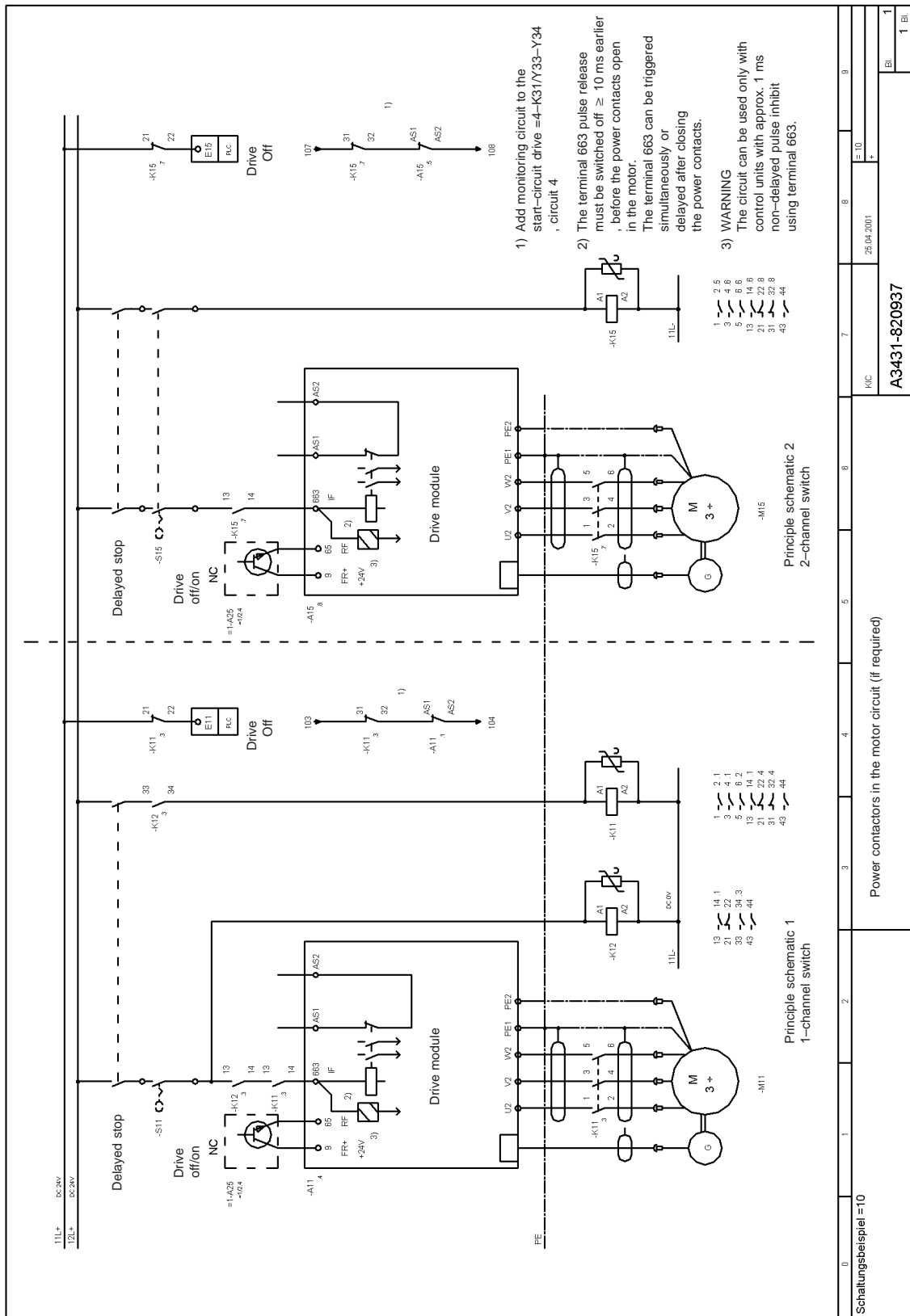

Fig. 8-22 =9 Power contactors in the motor circuit; Sheet 1/1



### 8.7.1 Function description, circuit examples =1 to =9

#### Higher-level information, instructions and functions

##### Connection information, technical data, selecting equipment and devices

When engineering the drive components, safety switching devices, contactors, shown in the circuit examples, it is absolutely necessary to carefully observe the associated connection information/instructions, technical data of the current Operating Instructions and Configuration Manuals as well as the appropriate Catalogs and Application Manuals.

##### Selection of the switching devices

- SIGUARD safety combinations 3TK28/3TK29; circuit examples as well as the "automatic start" and "monitored start" functions are described in the "Safety Integrated" Application Manual, Order No. 6ZB5000-0AA01-0BA1.
- SIRIUS power and auxiliary contactors 3 RT1 and 3 RH11 should be selected with positively-driven auxiliary contacts according to ZH1/457, IEC 60947-5-1.
- Contact reliability

The auxiliary contacts, switching contacts of the switching devices and the line isolation equipment must be able to reliably switch low switching currents  $\leq 17$  V, 5 mA.

- Overvoltage limiting

All of the switching devices, coils, inductances, brakes, etc., must be equipped, for EMC reasons and for reasons associated with the functional safety, with RC elements, varistors, diodes or diode combinations. These are intended to dampen overvoltages at switch-off if these damping elements are not already integrated in the devices.

This also applies to switching devices controlled from PLC outputs.

---

##### Note

The selection of the overvoltage limiting function also influences the off delay of the devices. This effect must be carefully taken into account when engineering the system.

Refer to NSK Low-Voltage Switchgear Catalog for selection and technical data

---

**Functions/safety aspects****Definition of the terminology**

"Powering-down in an emergency" EMERGENCY OFF and "Stopping in an emergency" EMERGENCY STOP

- Actions taken when an emergency arises according to EN 60204-1 (VDE 0113, Part 1): 1998-11, Section 9.2.5.4 should be interpreted as follows:
- Powering-down in an emergency: In Stop Category 0 according to EN 60204-1; 9.2.2 stopping is achieved by immediately disconnecting the power feed to the machine drive elements (i.e. uncontrolled stop). Generally, this type of power-down operation is interpreted as EMERGENCY OFF.
- Stopping in an emergency: In stop Category 1 according to EN 60204-1; 9.2.2, a system is stopped in a controlled way; in this case, the power feed to the machine drive elements is maintained in order to stop in a controlled fashion. The power feed is only interrupted when standstill has been reached. Generally, this type of stopping is defined as EMERGENCY STOP.
- In the circuit examples, when stopping in an emergency, the term EMERGENCY STOP function is used.

The EMERGENCY STOP buttons cause a shutdown according to Control Category 3 in compliance with EN 954-1 through two channels using the 3TK2806-0BB4/3TK2842-1BB42 safety relays. When required, the switching devices also allow an EMERGENCY STOP button to be connected in a configuration that is cross-fault circuit proof, Category 4 according to EN 954-1.

- Braking using terminal 64 – drive inhibit – at the current limit

By inhibiting terminal 64 – drive enable at the NE module or the monitoring module – the drives are stopped as quickly as possible at the selected current limit (torque limit)/ramp of the drive module.

- NE module regenerative feedback power

The power rating of the NE module is selected according to the rated power of the connected motors – reduced by a demand factor. When braking at the current limit, ensure that the braking power does not exceed the peak regenerative feedback power of the I/R modules (see Table 6.3) and the braking power of the pulsed resistors in the UI modules. In borderline cases, the NE modules should be dimensioned somewhat larger or additional pulsed resistor modules with external pulsed resistors should be used.

- Setpoint and actual position value interfaces

A complete drive module with power and control module with High Performance for 1FK6 motors is shown in a block diagram in Section 8.4.1. The setpoint is controlled via terminal X141. In circuit example = 1, the setpoint and actual position value interfaces of the NC control, e.g. 840D, are only shown once as a schematic sketch. These are not discussed any further in the additional circuits.

A detailed description of the control units is provided in Chapter 5.

- Motor holding brake

The holding brake must be controlled in a coordinated way with respect to time. For instance, using the PLC logic as a function of the pulse cancellation, controller enable and speed setpoint input. In this case, the times required for the holding brake to open and close must be taken into account. If the brake control is not optimally harmonized and coordinated, then this results in increased wear and premature loss of the braking performance.

### 8.7 Circuit examples =1 to =9 with SIMODRIVE 611

In the circuit examples, for a drive stop, the holding brake is disconnected with drop-out delay using the appropriate hardware in addition to the PLC control. This means that a PLC fault cannot result in the brake being incorrectly controlled when the drive is stationary. It must be decided, on an application-for-application basis, whether when stopping in emergency, the brake is to be shutdown instantaneously or with a delay. Using an internal sequence control, 611U controls allow a holding brake to be controlled in a coordinated way (refer to the Function Description for SIMODRIVE 611 universal).

Holding brakes must be provided with external circuitry to dampen overvoltages.

For detailed description, refer to the Configuration Manual for SIMODRIVE motors.

- **Safe standstill**

After the drives have stopped, by safely disconnecting the power feed to the motors, the drives are in the safe standstill condition. When the start inhibit is activated, then the pulses are safely cancelled in the drive modules.

#### **Features**

- The motor cannot be started accidentally.
- The power feed to the motor is safely disconnected
- The motor is not electrically isolated from the drive module or the converter DC link.

The machinery construction OEM must take the appropriate measures to ensure that the drives do not undesirably move after the power feed has been disconnected.

#### **Secondary conditions, e.g. for vertical/suspended axes:**

- Safe standstill is only guaranteed if the kinetic energy stored in the machine cannot result in an unpredictable motion of the drives/axes. For example, for vertical or inclined axes without weight equalization, motion can occur as a result of non-symmetrical rotating bodies or workpieces.
- The motor holding brake supports the safe standstill operating mode.
- When manually intervening in the automatic mode, when traversing in setup mode, as well as during service/maintenance and repair work, depending on the hazard analysis, it may be necessary to apply additional measures for personnel and machinery protection.
- Axes can be secured from dropping/falling or axes can be locked in a specific position using redundant devices in addition to the holding brake, e.g. using electromechanical or pneumatic locking devices with cyclic monitoring.

## Circuit example =1 "Cabinet supply, NC, PLC"

### Cabinet design and regulations relating to the implementation and design

When designing, constructing and implementing the electrical/control cabinets to accommodate the drive components, the following important regulations, among others, must be carefully observed:

- DIN EN 60439–1 (VDE 0660 Part 500) 2000–08 Low–Voltage Switchgear Combination
- DIN EN 60204–1 (VDE 0113 Part 1) 1998–11 Electrical Equipment of Machines, Safety
- DIN VDE 0106 Part 100 1983–03 Protection against Electric Shock.
- EMC and Low–Voltage Directive
- Enclosure/housing degree of protection IP 54 or corresponding to the requirements of the ambient conditions.

### Device selection

- Q1 line isolating device (main switch) with leading auxiliary contact when opening  
Selection, refer to Chapter 7.3.5 and Catalog NSK  
The line isolating device electrically disconnects the equipment from the power supply.
- G11 SITOP power supply unit for 24 V DC, refer to Catalog KT 10.1.  
The power supply and the connected circuits must fulfill the requirements of PELV = function extra–low voltage with protective separation. We recommend that regulated power supply units that limit the current are used, e.g. SITOP power.
- F11–F14 miniature circuit breakers 5SX or 5SY, refer to Catalog I2.1.  
The potential assignment of the circuits has been randomly selected. The max. permissible values of the protective elements must, under all circumstances, be carefully observed when protecting the safety relays and circuits.
- Line fuses for the NE modules, assignment refer to Chapter 7.3.1 and Section 6.2.5.
- Line filter, refer to Chapter 7.4 and Catalog NC 60
- Line commutating reactor, refer to Chapter 6.5.1 and Catalog NC 60

## Circuit example =2 "Drives on/off/stopping in an emergency"

### Application

Drive group, comprising an NE module, three 611 FD modules with High Standard control boards. This circuit concept can be used, for example, for basic drive controls. When the drives are powered up and powered down, the complete drive group, including the line contactor and start inhibit terminals, is switched in a safety-related fashion through two channels.

### Functions

#### Drives On

- Key-operated switch –S21, control on.

The power-off circuit before the EMERGENCY STOP safety relay –K21 – with the expansion devices –K22, –K23 – must be switched-in taking into account the following conditions:

- Contactor –K25 closes, ready signal from the NE module. (ready conditions, NE module, refer to Section 6.2.5!) When the control is powered-up, the ready signal is still not present. This means that the PLC output O25 must be set to "1" using the PLC logic so that the power-off circuit is closed through contactor –K25. After the drive group is switched in via the switching devices –K21, –K22, and –K23, the ready message is issued via PLC input I11, provided no error messages are pending.. The ready monitoring is now activated in the power-off circuit by means of the PLC logic.

The feedback circuit from contactor –K25 is monitored using PLC I25.

- Contact =A1–A25/1–2 NC ready (ready signal) must be switched through to the NC control.
- Interlock circuit terminal 35–36 is closed.
- The expansion devices –K22, –K23, the line contactor, the start inhibit functions/terminals and contactor –K27 for the brake control are now monitored, at each power-on cycle for the safety-related off switching condition. When required, safety-relevant functions of the machine control on the user side can also be incorporated in the feedback circuit.
- Pushbutton –S23, drives on

Contactors –K21, –K22, –K23 are closed and power-up the drive group. After the DC link pre-charging has been completed, the line contactor in the NE module is closed. The ready message is issued as long as there is no error message present.

#### NC program, start/stop

- Pushbutton –S29/–S28

The axis-specific controller enable signals are activated and the NC machining program is started using pushbutton –S29 NC program start. At the end of the program or using pushbutton –S28 – stop – the drives are brought to a controlled standstill.

**Drives, off**

Using pushbutton –S24 EMERGENCY STOP or –S22 Off, the drives, assuming that they have still not been stopped via the NC program, are braked and stopped as quickly as possible at the selected current limit of the drive modules. Terminal 64, drive enable, is inhibited and braking is initiated using the instantaneous contact of contactor –K22. After braking has been completed, the line contactor is opened using a safely overlapping shutdown time via the off delay contact of –K23 in a safety-relevant way through two channels via terminal 48 and NS1–NS2 of the line contactor; the drive inhibit functions are activated by inhibiting terminals 663. Fault signals of the drive system, interlocked using the PLC logic can be used, depending on the application, to brake along the current limit or for controlled braking along a setpoint ramp. The Off button also acts on PLC I22. This means PLC logic can be used to determine which switch-off command caused the drive group to be shutdown. The drive group can also be powered down via the PLC, logically combined, independent of the ready signal of the NE module using contactor –K25.

**Holding brake**

The holding brake is controlled, coordinated as far as the timing is concerned by the PLC logic through PLC O27. When the drives are stopped, the brake is additionally safely shutdown per hardware using an off delay contact of contactor –K23. This means that a PLC fault, when the drive is stationary, cannot cause the brake to be incorrectly controlled.

**Temperature sensor**

If the temperature monitoring is tripped because of overtemperature of a drive module and/or a motor, the 5.1–5.3 relay contact on the NE module activates the PLC–E12 input. Using the logical interlocking in the PLC, the drives must, depending on the application, be shutdown either instantaneously or delayed, e.g. using PLC O25 and contactor –K25.

**Circuit example =3 "Drives start/stop/safe standstill"****Application**

This control is used where one or several drives must be selectively shut down from an operational drive group using safety-relevant technology. The drive can be shutdown in a safety-relevant way from the drive group using a two-channel key-operated switch or, e.g. using light barriers or limit switches. Beforehand, the drive must have been safely stopped by the NC control. The "safe standstill" condition is achieved using the start inhibit function.

**Functions****Drives, start**

The 2-channel stop circuit in front of safety relay –K11 must be closed using the key-operated switch –S11 and the EMERGENCY STOP circuit contactor =2–K22. Contactor –K11 is closed with "monitored start" and latches using button –S12 – start – and the closed feedback circuit. Terminal 65, controller enable, and terminal 663, pulse enable, are energized.

The drive is moved and stopped in a controlled way using the NC program.

## 8.7 Circuit examples =1 to =9 with SIMODRIVE 611

**Stop drives**

Safety relay –K11 is de-energized using key-operated switch –S11 or when EMERGENCY STOP is pressed. The instantaneous contact withdraws terminal 65 "controller enable" and the drive is braked at the current limit. Terminal 663 is de-energized via the off delay contact –K11 and therefore the start inhibit activated.

**Start inhibit monitoring function**

The start inhibit monitoring function for terminals 35–36 is effective in the EMERGENCY STOP circuit of contactor =K2–K21.

Normally, when a drive is stopped, the NC contact AS1–AS2 of the start inhibit relay should always be closed before the NO contact of contactor –K13 opens. To ensure this, the contactor coil –K13 must be equipped with a diode to extend the contactor off delay. If the start inhibit function is incorrect, the monitoring circuit opens and disconnects the complete drive group through the line contactor.

The start inhibit is actively monitored in a cyclic manner after every stop operation.

**Holding brake**

The function is similar to that in circuit example =2

**Circuit example =4 "Drives, on/off/stopping in an emergency; start/stop/safe standstill"****Application**

Drive group, comprising an NE module, MSD module for 1PH7 motor and three FD modules 611 with High Standard control boards. Circuit =4 is the basic circuit for the drive-related control, e.g. of a machine tool. Using the subsequent circuit components =5 to =9 with the necessary interlock and monitoring circuits and the application-specific supplements, the control can be expanded in a modular way and therefore individually adapted to the particular application.

**Functions****Drives, on (NE module)**

- Key-operated switch –S21, control on.

The power-off circuit in front of the EMERGENCY STOP safety switching device –K21 must be closed under the following conditions:

- The interlocking circuits of the following expansions of circuit =7 are jumpered.
- Contactor –K25 closes and contact =A1–A25/1–2 NC ready is closed. The power-on conditions are almost comparable to circuit =2. The additional function is that the ready signal of the MSD module – PLC I15 must be interlocked in the PLC in addition to the ready signal of the NE module – PLC I11.

## 8.7 Circuit examples =1 to =9 with SIMODRIVE 611

- Pushbutton –S23, drives on

Contactors –K21 closes and latches. Initially, only the NE module is powered up. After the DC link pre-charging has been completed, the line contactor is closed. The ready signal is issued as long as there is no fault signal at the NE module and at the FD modules (switch, ready/fault signal is set to fault signal).

**Drives, start (drive modules)**

- The NE module must be powered up. The stop circuit in front of safety relay –K31 must be closed. The interlocking circuits of the following expansions of circuit =5 are jumpered.
- Using pushbutton –S32 – drives, start (monitored start) – with the feedback circuit closed, safety relay –K31 with expansion device –K32 and contactors –K35, –K33, –K36 are closed and latch.
- Simultaneously, terminal 63 central pulse enable, terminal 64 "drive enable" at the NE module and terminal 663 "pulse enables" for the drive modules are energized and therefore the start inhibit functions are withdrawn.

**NC program, start/stop**

- Pushbutton –S29/–S28

The axis-specific controller enable signals are activated and the machining program is started using pushbutton –S29 NC program start. At the end of the program or using pushbutton –S28 – stop – the drives are brought to a controlled standstill.

**Stop drives**

- Using the two-channel pushbutton –S31, drives stop – the drives are braked and stopped as quickly as possible at the selected current limit of the drive modules if these have not already been stopped by the NC program.
- Terminal 64 – drive enable – is de-energized by the instantaneous contact of contactor –K31. After the drives have come to a standstill, terminal 663 is inhibited and the start inhibit functions become active via the off delay contacts of the safety relays –K32 and –K35.
- The shutdown times are adapted to the various braking times of the MSD and FD drives and must safely overlap these from a time perspective, e.g. MSD 5 s; FD 0.5 s.

**Start inhibit monitoring function**

The start inhibit monitoring function for terminals 37–38 is effective in the EMERGENCY STOP circuit of contactor –K21. Normally, when the drives stop, the NC contacts AS1–AS2 of the start inhibit relays in the drive modules must always be closed before the NO contact of contactors –K33 and –K36 open. In order to realize this, the coils of these contactors must be equipped with a diode to extend the contactor drop-out delay. If the start inhibit function is incorrect, the monitoring circuit opens, EMERGENCY STOP contactor –K21 drops out and shuts down the complete drive group through the line contactor. The start inhibits are actively monitored in a cyclic manner after every stop operation.



## 8.7 Circuit examples =1 to =9 with SIMODRIVE 611

**Drives Off**

- Using the EMERGENCY STOP pushbutton –S24 or Off –S22 – the drives are braked and stopped as quickly as possible at the current limit. The function is similar in circuit diagram =2. After the braking time of the spindle drive, the –K31/–K32 contactor is used to switch off the drive group, i.e. line contactor off and start inhibits active.

**Holding brake**

The control is similar to circuit example =2

**Temperature sensor**

The function is similar to circuit example =2

In addition, the temperature monitoring function of the spindle drive must be evaluated via PLC I13 and –I14.

**Circuit example =5 "Drives, operating modes automatic operation/setting-up operation with agreement"****Application**

The operating mode changeover is used for most machines/plants, e.g. in setup mode, in order to traverse/operate sub-functions of the machine at a controlled, reduced velocity. In this particular operating mode, other sub-areas must be shutdown in a safety-related way to avoid potential hazards. The drives can only be operated with an agreement issued by the operator in the setting-up mode with reduced velocity/speed. This agreement can, for example, depending on the risk assessment, be issued from a secure location outside the hazardous zone of the machine or using a mobile hand-held unit with additional EMERGENCY STOP pushbutton in the operating zone of the machine.

**Notice**

In this case, the user is responsible for observing and complying with the specific technological and machine-specific regulations and standards to maintain the protection and safety of personnel and machinery. Further, residual risks must be evaluated – those risks that are due for example to vertical axes.

The start phase of the machine after power-on is especially critical. An agreement for a specific traversing motion should only be issued if the machine had previously moved in a controlled way.

**Functions****Operating modes**

The operating mode selector switch –S15 must be able to be locked as a key-operated switch or must be implemented in another way so that it can be locked-out.

**Notice**

The operating mode may only be changed when the drives are stationary and this must not result in a hazardous situation at the machine.

**AUTOMATIC mode**

The interlocking circuits terminals 51–52/53–54/55–56/57–58/511–512 should be inserted into circuit =4. The interlocking circuit terminals 611–612/613–614 is closed.

Key-operated switch –S15 is set to automatic, contactor –K15 pulls-in. The monitoring circuit, drives stop in front of contactor =4–K31 is closed via terminals 53–54/55–56. This means that the drives can be started under the power-on conditions specified in circuit example =4, using the pushbutton, drives, Start =4–S32.

**Set-up operation**

Key-operated switch –S15 is set to setting-up, contactor –K15 drops-out, contactor –K16 closes. The monitoring circuits terminals 53–54/55–56 are open. This means that the drives cannot be started. When the monitoring circuit, terminals 511–512 is opened, pushbutton =4–S32 – Start drives is ineffective in the setting-up mode.

Using the interlocking circuit terminals 57–58, the drop-out delay for contactor =4–K32, used for the shutdown time of the spindle drive is changed-over from 5 s, for example, to the shorter time of the FD drives, for example, 0.5 s. If a fault condition is present this means that the complete drive group is already shutdown after this shorter time. Further, with the changeover to setting-up, the speed setpoint for the drives is reduced via PLC I18. The speeds and feed velocities are therefore to be reduced to permissible values according to the type C Standard or the hazard analysis.

**Notice**

Setpoint limiting is not a safety-relevant function.

**Agreement function**

The safety relay –K11 and contactors –K13/–K14 are switched-in – if the feedback circuit is closed – using pushbutton –S11 – agreement (pushbutton with two positions).

The interlocking circuit is then closed through terminals 53–54/55–56. A start pulse must be generated via PLC I17 with a time delay  $\geq 80$  ms; this pulse is output at PLC O17. Contactor –K17 briefly pulls-in and issues the start commands for contactors =4–K31, –K32, –K33, –K35 and –K36 through terminals 51–52.

The start inhibit functions are withdrawn and therefore the drives are enabled in a safety-relevant way – as long as the agreement button is pressed.

Using the non safety-relevant PLC function keys – in conjunction with the hardware agreement function – the selected drives can now be individually traversed with reduced parameters.

**Notice**

No motion may be started by just pressing the agreement button alone. Note: When terminal 81 – ramp-function generator fast stop – is withdrawn, after every agreement command, the spindle induction motor must be re-magnetized and therefore starts with some delay  $\geq 0.5$  s.

## 8.7 Circuit examples =1 to =9 with SIMODRIVE 611

If hazardous operating states exist, if the PLC function keys fail, or for any other unpredictable situation, the drives can be stopped in a safety-related way by releasing the agreement button.

**Notice**

For dynamic drives with inadmissible speed increases, potential hazards can occur under fault conditions due to the response times of personnel and the delay when the agreement device switches. These hazards must be reduced by applying additional measures, e.g. a safety-related speed monitoring function. Various type C Standards, e.g. for machine tools, specify a safely monitored speed in the setting-up mode for spindle drives.

**Circuit example =6 "Drives, automatic operation with protective door monitoring"****Application**

In the automatic mode, the working zone of a machine is isolated using a moving, closed protective door (e.g. guard). In the circuit example, the protective door is interlocked and cannot be opened while the drives are running or if other hazardous operating states exist. This is realized using a position switch with tumbler mechanism with an interlock using spring force with sealed auxiliary release. Automatic operation for the drives is only enabled if the protective door is closed and interlocked via the position switch.

Depending on the hazard analysis, the user must decide whether, e.g. a second limit switch is additionally required for the door monitoring function.

The protective door is prevented from being opened as long as a hazardous state exists, e.g. as a result of the drives running-down. The enable signal is only issued with a time delay after the drive with the longest braking time has been reliably and safely stopped or optionally using the standstill signal of an external speed monitoring function.

For several applications, e.g. if personnel can enter the working area of a machine, the tumbler mechanism of the protective door is implemented using a position switch interlocked with magnetic force. This is for safety-related reasons. When the line supply or control voltage fails, the position switch can be used to release the protective door and allow it to be opened.

**Functions****Request protective door enable**

The drives must initially be shutdown using pushbutton =4-S31 – stop drives – or optionally, e.g. at the end of the NC program by the output of an NC auxiliary function, PLC O18 closes contactor –K18.

The protective door enable is requested using pushbutton –S15. Contactor –K15 is activated, interlocked through the PLC logic when the drives are stopped and shut down. This means that contactors =4-K33 and =4-K36 have dropped out. PLC logic: PLC O15 = "1", if =4-I33 and =4-I36 = "0" signal.

When requesting that the protective door is enabled, in the secured working zone of the machine/plant, all hazardous motion and other potential hazards of the user-side machine control must be shutdown. The shutdown must then realized in a safety-relevant way using the released or opened protective door.

**Releasing the protective door**

The protective door is released using contactor –K16 if the following conditions are fulfilled:

- Contactor –K15 is closed (energized)
- Drives, delayed stop, contactors =4–K33 and =4–K36 open (de-energized).
- MSD standstill signal n act < n min via relay =4–K11.
- User–side interlocking circuit is closed via terminal 601–602.

Optional:

- External standstill monitoring closed via terminal 77–78.

The interlocking solenoid of the door position switch –S11 is energized and the safety relay –K11 and contactors –K13/–K14 are de-energized via the position monitoring function of the solenoid. The drives are shutdown in a safety-relevant fashion through two channels via the interlocking circuit, terminals 611–612/613–614. The protective door is initially just released, but is still closed, relay –K17 is energized. Using the PLC, e.g. sub-functions of the user-side machine control, that are still not hazardous, can be executed.

**Opening the protective door**

By opening the protective door, the protective door safety circuit is opened via the actuator of the door position switch –S11 – redundantly to the position monitoring function of the solenoids.

**Closing the protective door**

The protective door must be closed. Using pushbutton –S16 – interlock protective door – contactors –K15/–K16 are de-energized (they drop-out) and the protective door is again interlocked. The interlock circuit is again closed through terminals 611–612/613–614 which means in the selected automatic mode, the drives can again be released using pushbutton =4–S32 – start.

For protective doors that are infrequently opened, we recommend that the control is adapted so that each time before the drives are powered up, the position switch function is checked by opening and again closing the door.

## Circuit example =7 "Limit switch, limitposition monitoring"

### Application/ functions

Normally, the end position (end stop) of the traversing range of the axes in the machine is monitored using software limit switches; these become active after the reference point approach. If, in a fault situation, a software limit switch is passed, and therefore a hardware limit switch actuated, then contactor =4-K21 is de-energized (opened) via the interlocking circuit, terminal 81-82 in the EMERGENCY STOP circuit. The drives are braked at the current limit and are then stopped.

However, electrical braking of an axis is only effective if there is an appropriate distance for the braking travel between the hardware limit switch and the mechanical end stop of the axis.

The actuated end position limit switches can be decoded using PLC inputs. In the setting-up mode, the axis can be moved away in the opposite direction using key-operated switch -S13 and button =5-S11 - "agreement".

## Circuit example =8 "Armature short-circuit braking"

### Application

Armature short-circuit braking is only possible when using permanent-magnet motors and is used, for example, when passing end position limit switches, when the power fails, for fault signals or EMERGENCY STOP with some delay.

When a software limit switch is passed, the fault/error is often in the NC, PLC or in the drive module itself. Electrical braking beyond the limit position limit switches according to circuit =8 is therefore no longer possible. For critical drives, e.g. vertical axes, in cases such as these, emergency braking is possible using armature short-circuit braking or optionally using a fast shutdown with a holding brake implemented with the appropriate hardware.

The braking torque for armature short-circuit braking is optimized using the additional braking resistor in the motor circuit.



---

### Caution

Short-circuit braking without a braking resistor can result in partial de-magnetization of the motor.

---

**Functions****Armature short-circuit**

The pulse enable is withdrawn via terminal 663 when the limit position limit switch is actuated/passed or when the power fails. The armature short-circuit contactor –K11 is simultaneously de-energized (opened). The drive is braked after the contactor drop-out time. The interlocking circuit, terminal 91–92, is simultaneously opened therefore initiating an EMERGENCY STOP function for all of the drives. A varistor is connected to the contactor coil in order to achieve a short contactor dropout time. The selected auxiliary contactor from the SIRIUS series of industrial controls with mounted, four-pole auxiliary contact element fulfills "protective separation" between the control voltage and the 690 V AC motor circuit. For operation with power failure and when the +24 V control voltage is buffered, or for other shutdown functions, the circuit must be appropriately adapted to the particular application.

**Holding brake**

The fast application of the holding brake, independent of the PLC cycle time using the armature short-circuit contactor, supports braking. When compared to armature short-circuit braking, there is a delay before the holding brake actually closes and starts to brake.

In the setting-up mode, the axis can be moved away using the key-operated switch –S13 – move away from end position – and pushbutton =5–S11 – agreement.

**Circuit example =9 "Power contactors in the motor circuit"****8****Application**

For special applications, the circuits allow the motor to be galvanically isolated from the drive module via contactors. The contactors may only be de-energized with a leading pulse inhibit  $\geq 10$  ms via terminal 663 with respect to the power contacts. When powering-up, the pulses must be simultaneously enabled when the power contacts are closed.

**Notice**

The contactors are generally not suitable for interrupting clocked inverter currents or interrupting DC currents of a stationary drive that is in closed-loop position control. If this is not carefully observed, this can result in high voltage peaks/spikes when powering-down and in turn can destroy the drive module, the motor winding and/or cause the contactor contacts to weld.

**Functions**

The drives are powered-down in a safety-relevant way using key-operated switch –S11 through one channel or –S15 through two channels – a) using the start inhibit function and b) also using a contactor to galvanically isolate it from the drive module.

The pulse enable is withdrawn before the power contacts of the power contactor open as a result of the drop-out delay. The interlocking circuit, terminals 103–104 or terminals 107–108, should be inserted in the start circuit of the safety combination =4–K31/Y33–Y34, drives stop.

8.8 Information and instructions regarding applications

8.8 Information and instructions regarding applications with 611 digital/611 universal

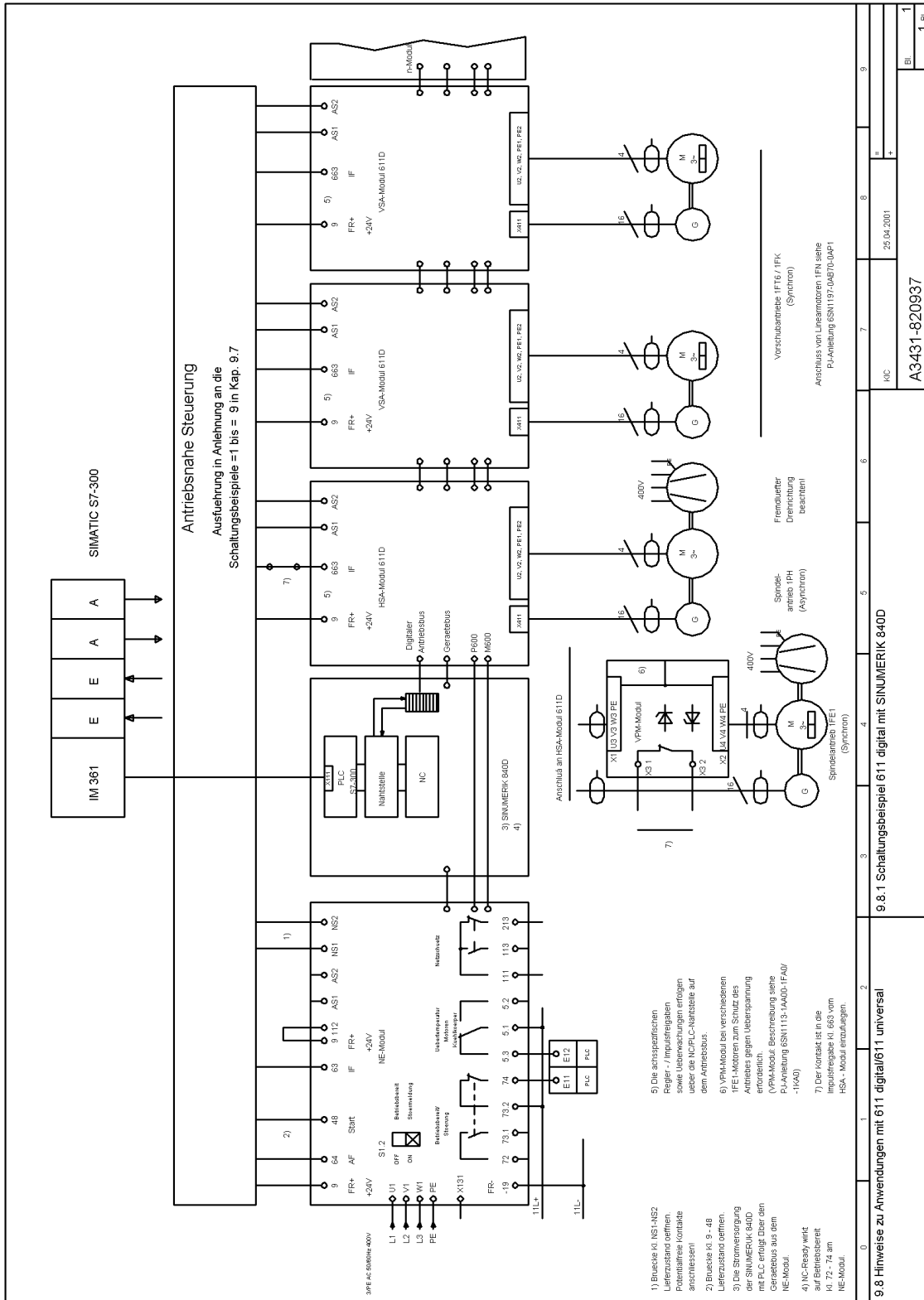

Fig. 8-23 Circuit example, 611 digital with SINUMERIK 840D

### 8.8.1 Circuit example, 611 digital with SINUMERIK 840D

A circuit example SIMODRIVE 611 digital and SINUMERIK 840D with the drive-related control for a machine/plant, based on the circuit examples in Fig. 8-23 with 611 in its principle form, is shown in Section 8.7.

### 8.8.2 Circuits with 611 digital

The digital control units 611 digital have a digital setpoint and actual position value interface to the 840D or 810D NC control systems. The boards are available as either 1-axis or 2-axis modules with High Performance or High Standard control.

Further, the units differ in the connection version:

- Incremental encoder as motor encoder (indirect measuring system), or
- Incremental encoder as motor encoder (indirect measuring system) and connection for a direct measuring system encoder

For a description of the interfaces of the 611 digital control units  
—> refer to Chapter 5.

All of the NC control communications to the 611D drive modules are realized via the digital drive bus. The axis-specific controller and pulse enable signals as well as the operating and monitoring signals are placed on the digital drive bus via NC/PLC interface signals.

The terminal 663 pulse enable/start inhibit for the 611D modules is provided on a module-for-module basis. The axis-specific pulse enable signals received via the drive bus are logically ANDed with the signal state at terminal 663.

#### Control with SINUMERIK 840D

The NC control with the integrated PLC-CPU SIMATIC S7-300 is accommodated in a 50 mm wide housing that is compatible to the SIMODRIVE drive modules.

The control is integrated in the SIMODRIVE 611D drive group and can be expanded up to 31 axes. It is located between the NE module and the first drive module in the drive group. The power supply for the internal control voltage is derived from the NE module power supply via the equipment bus. The NC ready signal acts on the ready signal terminal 72-74 of the NE module via the equipment bus.



### 8.8 Information and instructions regarding applications

#### Control with SINUMERIK 810D

SINUMERIK 810D is a highly integrated compact control accommodated in a 150 mm wide housing – compatible to the SIMODRIVE modules – with integrated PLC–CPU SIMATIC S7–300 and 611D power and control sections onboard. The control is available in two versions:

- CCU box with three integrated power modules
  - 2 x 6 A/12 A for FD
  - 1 x 18 A/36 A for FD or 1 x 24 A/32 A for MSD
- CCU box with two power modules
  - 2 x 9 A/18 A for FD

The controller can be expanded with axis expansions consisting of up to five (four) axes + one spindle with separately attached power units. The closed–loop controls are already integrated into the CCU modules. Just like the SINUMERIK 840D, the control power supply is taken from the NE module power supply via the equipment bus.

The NC ready signal acts on the ready signal terminal 72–74 of the NE module via the equipment bus. The control has one hardware terminal 663 pulse enable/start inhibit for all axes together. The closed–loop controllers and pulses are enabled on an axis–for–axis basis and are controlled on the digital internal drive bus via NC/PLC interface signals. The safety–relevant drive–related control for a machine/system with SINUMERIK 810D can be engineered on the user–side based on the circuit examples in Section 8.7.

#### 8.8.3 Circuits with 611 universal HRS

The SIMODRIVE 611 universal HRS control board is available as either 1–axis or 2–axis module.

The setpoint can either be entered as analog signal or via PROFIBUS.

The interfaces are described in Chapter 4.

Implementation of the safety–relevant, drive–related control for a machine.

The SIMODRIVE 611 universal control board with analog setpoint interface can be used in a comparable fashion to the circuit examples =1 to =9 in Section 8.7.

## 8.9 Master/slave operation, SIMODRIVE 611

### Application example, master/slave

Two SIMODRIVE main spindle drives can be operated, rigidly and mechanically coupled together if the master drive is closed-loop speed controlled and the slave drive is closed-loop torque controlled.

The application of a master/slave function with "SIMODRIVE 611 universal HRS" is shown in the following example:

The master specifies the torque setpoint for the slave via an analog output (terminals 75.x/15 or terminals 16.x/15).

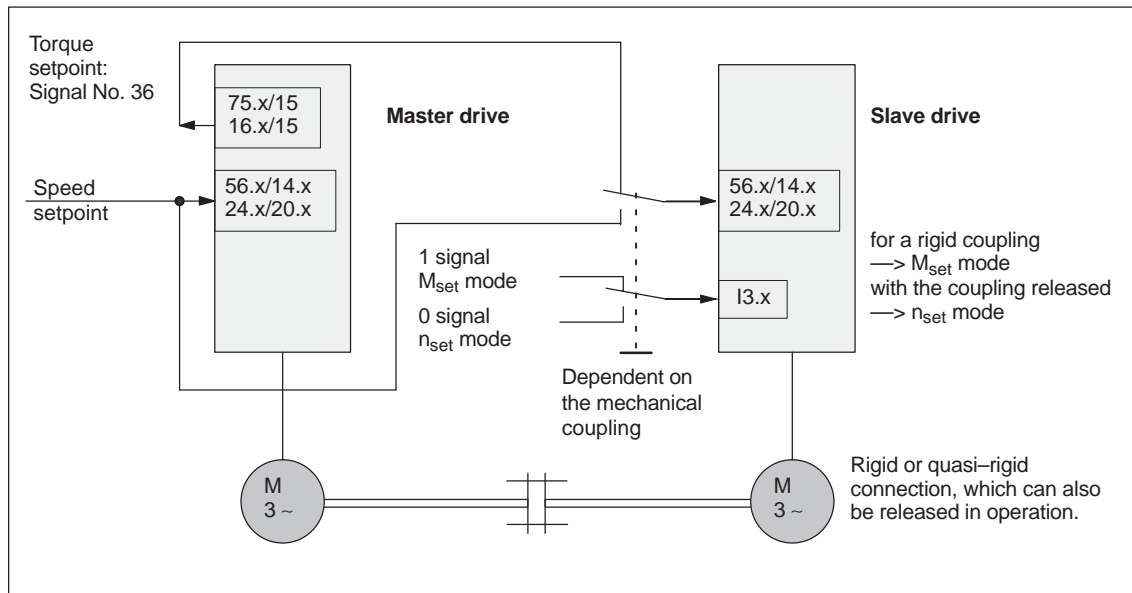

Fig. 8-24 Master/slave operation with SIMODRIVE 611 universal HRS



### Warning

If the rigid mechanical coupling is released, then the slave drive must be simultaneously changed-over to "closed-loop speed control" as otherwise inadmissibly high speeds could occur, which could result in malfunctions.

For information and data on the settings and parameterization associated with this master/slave mode as well as additional possibilities regarding axis couplings, refer to:



### Reader's note

For information and data on the settings and parameterization associated with this master/slave mode as well as additional possibilities regarding axis couplings, refer to:

**References:** /FBU/ SIMODRIVE 611 universal, Description of Functions

**References:** /FB3/ Description of Functions SINUMERIK 840D/840Di/810D TE3: Speed/torque coupling, master-slave  
M3: Axis coupling and ESR

## 8.10 Star–delta mode

### Application

SIMODRIVE 611 supports the use of motors that can changeover between star/delta configurations.

At lower speeds, the drive is operated in the star circuit configuration (high torque) and at higher speeds, in the delta circuit configuration (high stall torque). Changeover is also possible during operation.

The speed when changing–over from a star into a delta configuration (star to delta operation) must lie within the stall power range for star operation (refer to the speed–torque diagram for Y/Δ operation).

A star–delta changeover is only permitted below the star field–weakening speed.

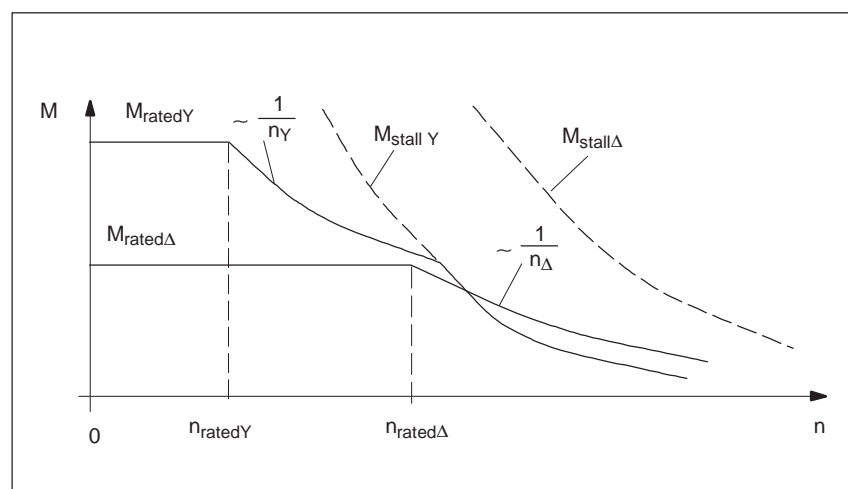

Fig. 8-25 Speed–torque diagram for Y/Δ operation of induction motors

### Note

If, in the delta mode, a torque lower than  $M_{rated}$  is taken, an appropriately smaller power module can be selected (as a maximum up to root 3)!



### Warning

During the phase when changing–over from Y to Δ operation, no torque may be demanded from the 1PH motor. In this case, a minimum dead time of 0.5 s must be taken into account for contactor changeover times, safety margins, de–magnetizing and magnetizing operations.

The star–delta operation of synchronous motors with 611D modules is used to extend the speed range.

The speed range selection may be changed only in the stopped state.

**Danger**

If synchronous motors are operated with speeds that require a VPM, the star–delta contactors must be protected using a safe power supply so that in case of fault, this contactor remains reliably switched on until the motor has reached uncritical speeds (EMC voltage)!

This must be proved in a risk evaluation of the machine/plant constructor!

**Connection example**

Connection diagram for Y/Δ changeover, 1PH Motor with SINUMERIK 840D

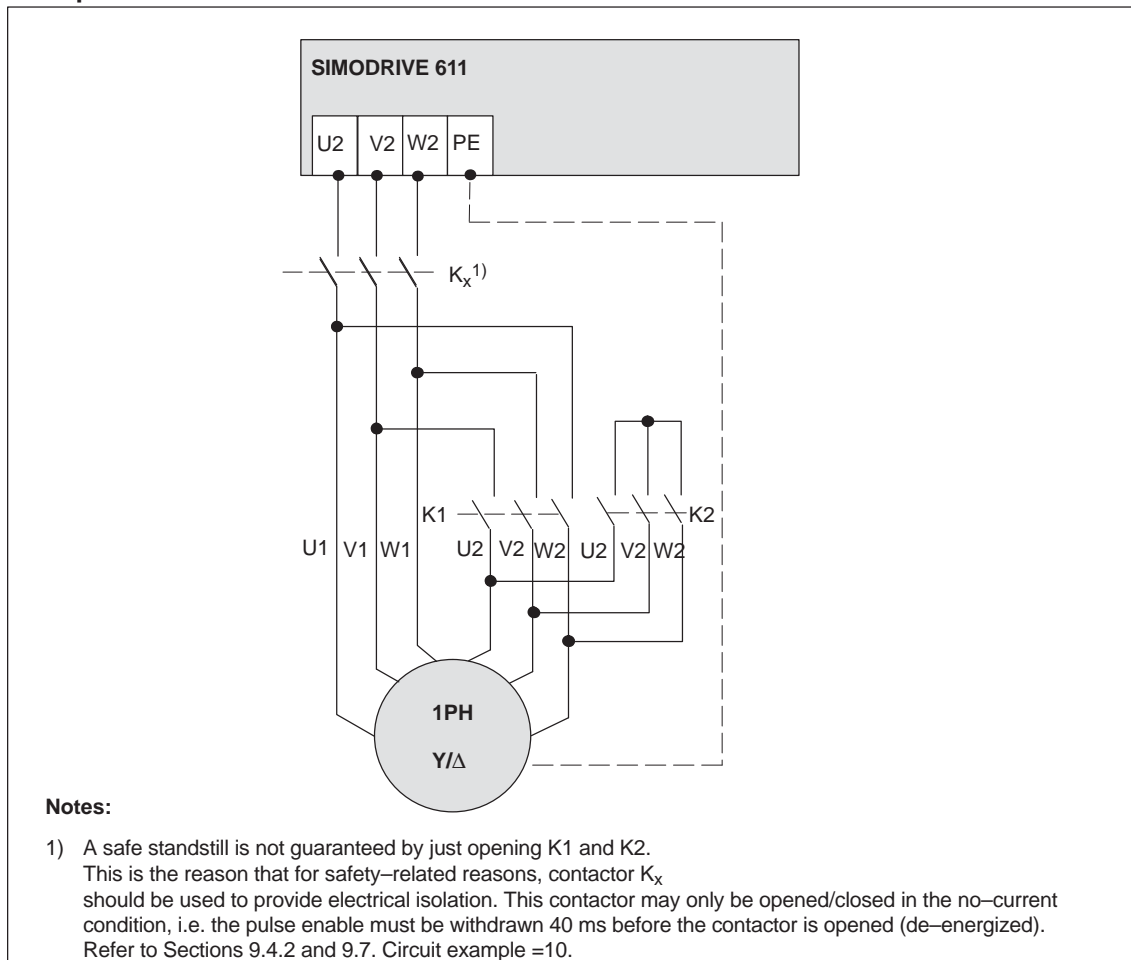

Fig. 8-26 Connection diagram for Y/Δ changeover with SIMODRIVE 611

The connection diagram for Y/Δ changeover 611 universal HRS can be engineered, based on the previous examples. For a description of the function, refer to the separate Configuration Manuals and documentation for SIMODRIVE 611 universal.

## 8.10 Star–delta mode

**Dimensioning and selecting the contactors**

The main contactors must be dimensioned/selected, harmonized and coordinated with the rated motor current and the overload factor.

The following table showing the assignment between 1PM4/6 motor/main contactors and auxiliary contactors can be used to provide configuration support:

Table 8-3 Dimensioning and selecting the main contactors for 1PM motors

Three-phase motor	Power [kW]	I <sub>rated</sub> [A]	Recommended contactor type/K1/K2 duty Category AC 1	Recommended auxiliary contactor type K1h, K2h
1PM4101–2LF8...	3.7	13.0	3RT1023	3RH11
1PM4105–2LF8...	7.5	23.0	3RT1025	3RH11
1PM4133–2LF8...	11	41.0	3RT1026	3RH11
1PM4137–2LF8...	18.5	56.0	3RT1035	3RH11
1PM6101–2LF8...	3.7	13.0	3RT1023	3RH11
1PM6105–2LF8...	7.5	23.0	3RT1025	3RH11
1PM6133–2LF8...	11	41.0	3RT1026	3RH11
1PM6137–2LF8...	18.5	56.0	3RT1035	3RH11
1PM6138–2LF8...	22	58.0	3RT1035	3RH11

## 8.11 Series reactor in the motor lead

### General

For special motors with a low leakage inductance (where the controller settings are not adequate) it may be necessary to provide a series reactor as 3–arm iron reactor (not a Corovac reactor) and/or increase the inverter clock cycle frequency of the converter. Motors with a low leakage inductance are, from experience, motors that can achieve high stator frequencies (maximum motor stator frequency > 300 Hz) or motors with a high rated current (rated current > 85 A).

### Selection/ calculations

- The voltage rate-of-rise (gradient) of the drive converter has typical values such as:

$du/dt$  up to 7 kV/ $\mu$ s

For third-party motors where the insulation is unknown or not designed for this voltage rate-of-rise, a series reactor should be used, independent of the selected pulse frequency.

- In the IM mode, motors can be used with a maximum rated torque of:

$$M_n = \frac{P_n \cdot 60}{2\pi \cdot n_n} \leq 650 \text{ Nm}$$

The inductance value of a series reactor or the necessary drive converter pulse frequency can be estimated using the following formula. However, it must be taken into account that when the inverter clock cycle frequency is increased, the module current must be reduced; or, a module with a higher current rating must be selected:

$$L_{\text{series}} \approx \frac{U_{\text{DC link}} \cdot n_{\text{max}}}{30 \cdot f_T \cdot n_{\text{FS}} \cdot I_0} - \frac{L_{\sigma 1} + L_{\sigma 2}}{2}$$

$L_{\sigma 1}$  Stator leakage inductance of the motor in H

$L_{\sigma 2}$  Rotor leakage inductance of the motor in H

$L_{\text{series}}$  Inductance of the series reactor in H (=0, if a series reactor is not used)<sup>1)</sup>

$V_{\text{DC link}}$  Voltage  
(=600 V or 625 V for a regulated infeed,  
= rectified line supply voltage for a non-regulated infeed  
e.g. 570 V at 400  $V_{\text{rms}}$  line supply voltage)

$f_T$  Inverter clock cycle frequency of the converter in Hz,  
refer to Chapter 5.4.1

$n_{\text{max}}$  Max. motor speed

$n_{\text{FS}}$  Speed at the start of field weakening

An approximate value can be calculated with  $n_{\text{FS}} \approx \frac{V_{\text{DC link}} \cdot n_n}{1.6 \cdot V_{\text{nmot}}}$

$I_0$  Motor no-load current in  $A_{\text{rms}}$

$V_{\text{nmot}}$  Rated motor voltage in  $V_{\text{rms}}$

$n_n$  Rated motor speed

1) For calculated/theoretical inductance values less than 0.1 mH, a series reactor is not required.

For calculated inductance values > 0.4 mH, 0.4 mH must always be assumed as maximum value.

## 8.11 Series reactor

If the motor data are not known, then for motors with a high current (rated current > 85 A), the converter current should be dimensioned for a pulse frequency of 4950 Hz. This means that a drive converter reduction factor of approx. 83% is obtained.

- For motors that require a higher motor frequency than 500 Hz, the drive converter pulse frequency must be increased.

The following formula applies:

$$f_T \geq 6 \cdot f_{\max \text{ mot}}$$

$f_T$  Inverter clock cycle frequency of the drive converter in Hz,  
refer to Chapter 5.4.1

$f_{\max \text{ mot}}$  Max. motor stator frequency

It should be noted that for inverter clock cycle frequencies above 3200 Hz, the module current rating must be reduced or, if required, a module with a higher-current rating must be selected.

- The max. field-weakening range for induction motor operation is limited.

The following relationships apply:

$$\frac{n_{\max}}{n_{FS}} \leq \begin{cases} 2 & \text{for high-speed motors (max. output frequency > 300 Hz),} \\ & \text{Standard motors} \\ 5 & \text{for wide-range motors} \end{cases}$$

$n_{\max}$  Max. motor speed

$n_{FS}$  Speed at the start of field weakening for the motor

An approximate value can be calculated with  $n_{FS} \approx \frac{U_{DC \text{ link}} \cdot n_n}{1.6 \cdot V_{nmot}}$  (refer above)

If a motor is changed-over from delta to star operation and vice versa, and auxiliary and main contactors are required for each motor. The motor contactors must be mutually interlocked. The changeover is only made when the pulses are inhibited using select terminal signals. When the changeover command is issued, the motor data set is re-loaded and the auxiliary contactors are controlled via the selector relay.

Parallel operation of several induction motors, refer to Chapter 8.12.1.

- The voltage drop across a series reactor depends on the motor current and the motor frequency. If an unregulated infeed is used, the maximum rated motor voltage depends on the line supply voltage available.

If these guide values are not observed, then this can have a negative impact on the power (lower power) in the upper speed range.

## 8.12 Induction motor operation

### 8.12.1 Operating several induction motors in parallel

Several motors can also be operated in parallel on a power module, for each axis. When selecting the motor and drive module, several engineering guidelines must be observed.

When expanded to the maximum, a drive configuration for parallel operation can comprise up to eight motors. Motors connected to a drive module in parallel must have the same  $V/f$  characteristics. Further, we recommend that the motors have the same number of poles. If more than two motors are connected to a drive module, then these should essentially have the same power ratings.

For a 2-motor configuration, the difference between the power ratings of the motors should not exceed a ratio of 1:10.

The following engineering guidelines must be carefully observed:

- Selecting the size of the drive module
  - Steady-state operation of the motors connected in parallel – namely in the closed-loop controlled range ( $> n_{\min}^{1)}$ ) and preferably in the rated speed range:
 
$$\Sigma \text{ rated motor currents} \leq \text{rated current of the drive module}$$
  - Operation of motors connected in parallel with dynamic load (where the load condition changes quickly) and in the open-loop controlled range require an additional dimensioning:
 
$$1.2 (\Sigma \text{ rated motor currents}) \leq \text{rated current of the drive module}$$
  - The current limit of the drive module must be increased to 150% of the rated current when commissioning the system.
- The motors should not be subject to torques that exceed their rated torque.
- For special high-speed induction motors, e.g. for woodworking, a series reactor must always be located between the drive module and the motor group:

Rated reactor current: rms current of the motor group<sup>2)</sup>

When the above information and instructions are taken into consideration, the individual motors are able to correct even for dynamic load and speed steps. "Stable" operation without stalling – also for individual motors – is achieved when following the dimensioning guidelines specified above. The speeds of the individual motors depend on the load. The currently set speeds can drift apart by several percent due to the closed-loop group slip control.

---

1) Standard motor:	2-pin → > 600 RPM
	4-pin → > 300 RPM
	6-pin → > 200 RPM
	8-pin → > 150 RPM
Special motors:	$n_{\min} > \frac{40 \text{ V} \cdot n_{\text{rated}}}{U_{\text{rated motor}}} > \frac{600 \text{ RPM}}{\text{No. of pole pairs}}$

2)  $\Sigma$  Rated motor currents, or when taking into account the load duty cycles, the total rms current of the motor group.



## 8.12 Induction motor operation

Load surges and overload conditions in the field-weakening range can result in oscillation and should be avoided.

The drive module cannot detect if an individual motor is overloaded.

Individual thermal monitoring functions must be provided to ensure that each individual motor has overload protection. We recommend that the motor is monitored using a PTC thermistor evaluation circuit.

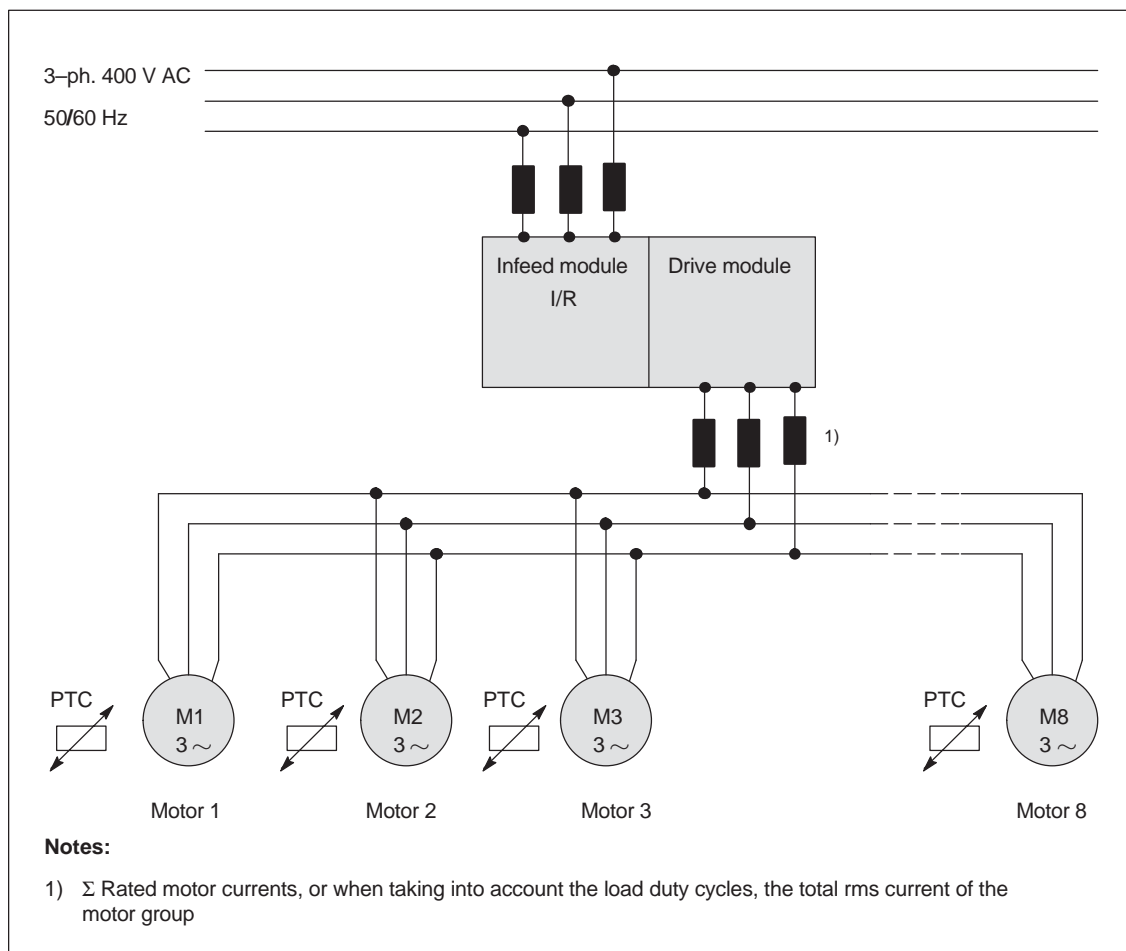

Fig. 8-27 Motors connected in parallel to SIMODRIVE 611

### Notice

For parallel operation, all of the motors must always be operated simultaneously. The motor data set must be adapted, e.g. by using a motor changeover function, when a motor is shutdown, e.g. when a fault condition develops.

When motors are connected in parallel, motor cable protection must be implemented outside the drive converter.

### 8.12.2 Selecting individual induction motors 611

The "SIMODRIVE 611 universal HRS" drive allows up to four different motors to be selected. Every motor has its own motor parameter set.

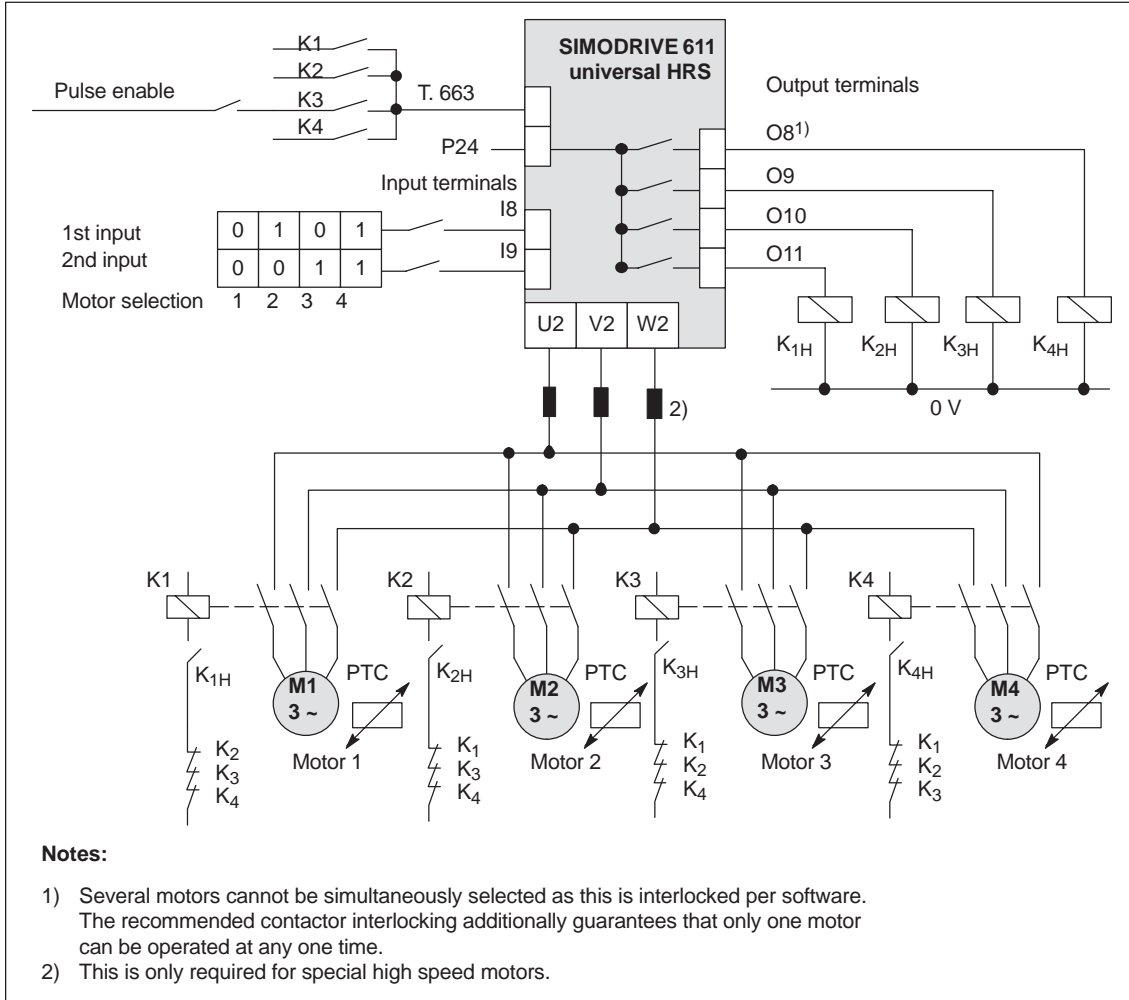

Fig. 8-28 Motor changeover at SIMODRIVE 611 universal HRS

For the motor selection circuit, one 3RH11 auxiliary contactor and one 3RT10 main contactor are required for each motor.



#### Reader's note

For additional information and possibilities for selecting and changing-over induction motors, refer to:

**References:** /FBU/ SIMODRIVE 611 universal, Description of Functions

**Overload protection**

Individual thermal monitoring functions must be provided for overload protection of the individual induction motors. We recommend that the motor is monitored using a PTC thermistor temperature sensor (embedded in the motor) and a 3RN1 thermistor motor protection evaluation unit.

If motor feeder cables have to be protected where the rated drive converter current is significantly greater than the rated motor current then this must be implemented outside the drive converter.

---

**Notice**

Motors may only be changed over using the power contactors in the motor circuit when terminal 663 – pulse enable/start inhibit – is inhibited (de-energized). This means that the power contactor may only be switched when the motor circuit is in a no-current condition.

For additional information also refer to circuit examples =9 in Section 9.7

---

## 8.13 Operation when the power fails

### 8.13.1 Application and mode of operation

The function "operation with the power fails" (power failure buffering) is used, for example, for machines where personnel could be in danger or significant machine damage could occur due to a danger of collision when machining due to power failure or for internal control fault signals. Further, the function is used for machines with complex machining operations. For example, when machining gear wheels (hobbing, roller grinding) where expensive tools and workpieces are used and which should be protected from possible damage if power failures were to occur.

For operation when the power fails, stopping and/or retracting drive motion, the energy stored in the capacitors of the power DC link and the kinetic energy of the moved masses stored when the drives regenerate into the line supply can be briefly used. To do this, a connection must be established from the power DC link P600/M600 to the auxiliary power supply via the terminals P500/M500 in the NE module or in the monitoring module.

Further, additional circuit measures are required. For example, the control voltages must be buffered and a power failure and/or DC link monitoring function to initiate the appropriate control functions.

After a hazard analysis, the machinery construction OEM must evaluate these risks and requirements and apply appropriate measures to avoid such hazards or damage.

The requirements placed on the power failure concepts differ significantly depending on the user and machine and must therefore be individually engineered.

### 8.13.2 Functions

An essential criterion when implementing power failure concepts is to be able to quickly detect a line supply fault (power failure, line supply undervoltage or phase failure).

When a line supply fault occurs, the DC link voltage quickly dips/fails due to the power drawn by the drives and the connected power supplies for the drive and control components. The discharge time depends on the DC link capacity, the charge (voltage) and the loading after the power failure.

Operation when the power fails with initiation of the regenerative feedback of one or more drives into the DC link must become effective before the DC link voltage decreases below the rated voltage, e.g. 600 V DC to 350 V DC. At approx. 350 V, the pulses are internally inhibited in the drive group, and the drives coast down.

The DC link voltage of 600 V DC is proportionally emulated at the control level and can be evaluated in the 611 digital and 611 universal control units via the equipment bus. The DC link voltage can be monitored to provide a fast response using parameterizable limit value stages, e.g. to 450 – 500 V. This therefore allows indirectly, an immediate response to be made to a line supply fault, e.g. power failure.

### 8.13 Operation when the power fails

The ready signal via terminals 72–74 in the NE module also responds when a line supply fault occurs and inhibits the pulses in the NE module. The response time is, among other things, dependant on the line supply impedances and other quantities and can therefore not be precisely calculated in advance. Generally, the power failure detection time is >30 ms and is alone not sufficient to initiate functions for operation when the power fails (line supply failure).

#### Operation when the power fails with the SIMODRIVE 611 universal HRS

Example:

The DC link voltage is monitored using the limit value stage of a 611 universal HRS control board in the SIMODRIVE 611 universal HRS. When a selectable limit value is undershot, e.g. a DC link voltage of 550 V, the limit value stage responds and switches a positive output signal from +24 V to 0 V via a digital output stage. For example, terminal 64 – drive enable – can be inhibited in an "AND" logic operation with the relay contact of the ready signal of terminals 72–73.1 of the NE module. The drives are braked and stopped as quickly as possible at the current limit.

In addition, for example, via a second digital output of the 611 universal module, the setpoint polarity of a drive can be changed–over and retraction motion initiated for a drive before the other remaining drives are braked, delayed via terminal 64.

The safety–relevant circuit examples in Section 8.7 for the drive control must be appropriately adapted by the user for operation when the power fails (line supply fault).

Additional possibilities for braking when the power fails:

Braking using armature short–circuit braking for permanent–magnet servomotors, refer to circuit example =8 in Section 8.7.

---

#### Note

The power failure monitoring device must directly interrupt the coil circuit of the armature short–circuit contactor as a buffered +24 V power supply will either respond too late or not even respond at all.

---

Braking by quickly applying the holding brake, bypassing the PLC cycle time, refer to circuit example =8 in Section 8.7.

---

#### Note

The holding brake is not an operating brake and can only be conditionally used for such braking operations.

---

**Operation when the power fails with SIMODRIVE 611 digital in conjunction with SINUMERIK 840D**

Extended stopping and retraction: ESR

These more complex functions can be used in conjunction with the optional software NC functions that can be used in SINUMERIK 840D and the digital drives 611D with High Performance controls.

For certain machining technologies where several drives, for example, interpolate with one another using electronic gear functions, when the power fails, these drives must be stopped or retracted in a coordinated fashion using special NC functions.

The user must engineer these functions for the special requirements of the particular machining process or technology.

Also here, the DC link voltage is monitored for a lower threshold value that can be parameterized. When a limit value, selected using a machine data is fallen below, within just a few interpolation clock cycles, the NC quickly responds via the digital drive bus and stops the drives in a controlled fashion and/or raises, retracts the tool from the machining contour.

Further, for example, when a connection between the NC and the drives is interrupted, for a sign-of-life failure of the NC or other selected fault signals in the drive system, the drives can be stopped/retracted using a drive-based function, i.e. a function that runs autonomously in the drives.

When the power fails, the energy required to stop/retract the drives is supplied from the energy stored in the capacitors of the power DC link.

If the energy is not sufficient, the DC link capacitance can be increased by adding additional capacitor modules, refer to Chapter 6. However, the charging limit of the I/R module must not exceeded.

However, for cases where the energy stored in the DC link is still not sufficient to stop/retract the drives, an additional energy storage device can be activated through regenerative operation. As an autonomous drive mode when line supply faults occur, it provides the necessary energy for the drive DC link.

A detailed description of "Extended stopping and retraction" –ESR– is contained in the following reference:

**References:** /FB3/ SINUMERIK 840D/840Di/810D  
Special Functions Part 3 "Axis couplings and ESR".

Dynamic energy management enables I/RF unit dimensioning to be adapted to the plant concept in accordance with requirements.

A detailed description of "Dynamic Energy Management" is contained in the following reference:

**Reference:** /FBA/ SINUMERIK 840D/840Di/810D  
Drive Functions, Function Manual (DE1)

### 8.13 Operation when the power fails

**The following control and secondary conditions/limitations must be carefully taken into consideration when engineering and configuring power failure concepts:**

- The braking energy must be converted into heat using one or more pulsed resistor module(s) – or for unregulated infeed units, using the internal pulsed resistor (it may be necessary to use, in addition, an external resistor). When the drives brake, the DC link voltage may not fall below or exceed the max. set monitoring thresholds.
- The safety–relevant hardware control must, when the power fails, e.g. briefly maintain the enable signals via terminals 48, 63, 64, NS1, NS2 and 663. Further, the internal axis–specific enable signals of the NC/PLC interface via the digital drive bus must also be maintained until the drives come to a standstill.
- For controlled retraction motion, holding brakes must remain energized, if required, until the operation has been completed and clamping operations must be released.
- The external +24 V power supply for the control voltage must be buffered using power supply units, e.g. SITOP power with capacitor or battery back–up. This maintains the drive enable signals, the PLC functions, and the control and machine functions on the user side.
- During the braking and retraction phase, it is not permissible that the NC and PLC controls generate fault signals that inhibit the drives.
- The power supply of the SINUMERIK 840 D with the integrated PLC–CPU is supplied through the DC link of the NE module when the power fails.

#### 8.13.3 DC link buffering

The energy stored in the DC link of the drive units can be used when the power fails. Capacitor modules are used to increase the DC link capacitance. This means that on one hand, a brief power failure can be buffered and on the other hand, it is also possible to store the braking energy.

---

#### Note

Examples to calculate and select a capacitor module, refer to Chapter 6.7.1.

---

#### Energy balance

When configuring the emergency retraction, it is always necessary to consider the energy flow (balance) to find out whether you can do without an additional capacitor module or a generator axis/spindle (with correspondingly dimensioned flywheel effect).

## 8.14 SINUMERIK Safety Integrated

### General information

"SINUMERIK Safety Integrated" offers type-tested safety functions which allow highly effective personnel and machine protection to be implemented in-line with that required in practice.

All safety functions satisfy the requirements specified in 954-1, Category 3, Performance Level d in accordance with EN ISO 13849-1, SIL 2 in accordance with EN 61508 and are a standard part of the base system.

Neither additional sensors nor evaluation units are required; this means lower installation time and costs at the machine and a "low profile" electrical cabinet.

The function scope includes, e.g.:

- Safety-relevant monitoring of velocity and standstill (zero speed)
- Safety-relevant traversing range demarcation and range identification/detection

### Reference

Please refer to the following documentation for a detailed description of SINUMERIK Safety Integrated:



#### Reader's note

**References:** /FBSI/ Description of Functions, SINUMERIK Safety Integrated  
/HBSI/ Application Manual, Safety Integrated

### Direct connection of two-channel I/O signals

Using the additional, integrated functions in the safety package "Safety Integrated" for SINUMERIK 840D/611D, for the first time, it is also possible to directly connect two-channel I/O signals – for example, an Emergency Stop button or light barriers. Logic operations and responses are performed internally using safety-related technology.

### Mastering extreme conditions professionally

All safety-relevant faults/errors in the system always cause potentially hazardous movement to be brought to a standstill or the motor to be contactlessly disconnected from the line supply. The drives are brought to a standstill in the optimum way, adapted to the operating conditions of the machine. This means, for example, in the setting-up mode with the protective door opened it is possible to stop axes as quickly as possible path-related – and also in the automatic mode with closed protective door.

This means: High degree of protection for personnel in the setting-up mode and additional protection for the machine, tool and workpiece in the automatic mode.

### Highly effective safety concept

The safety functions provide a previously unknown, intelligent and direct link right through the system to the electric drives and measuring system. Reliable operation, fast response and wide acceptance mean that this certified safety concept is extremely effective.

### Safety functions incorporated redundantly

A two-channel, diverse system structure has been formed on the basis of the existing multi-processor structure. The safety functions have been configured redundantly in the NC, drive and internal PLC. A feature of this safety concept is that a measuring system, the standard motor measuring system, can already satisfy the safety requirements. A second sensor is not necessary but can be added as an additional, direct measuring system, e.g. linear scale.

### Innovative safety technology setting new standards

It has been clearly seen that new practical machine operation concepts can be implemented with this innovative safety technology. The result is a new standard for machines which makes them safer and more flexible to use and which increases the availability of the entire plant.



8.15 Examples of correctly and incorrectly connecting NE

8.15 Examples of correctly and incorrectly connecting NE to the line supply

8.15.1 Three-conductor connection to the line supply

Note

- All X181 connections of a drive group must be electrically switched in parallel!
- A maximum of four monitoring modules may be connected at X181 of an NE module.
- If a DC link is buffered (DC link connection), the voltage must always be taken from between the reactor ( $L_k$ ) and the line supply infeed (NE).
- For all of the following examples, cables must be routed so that they are short-circuit and ground-fault proof (or fuse)!

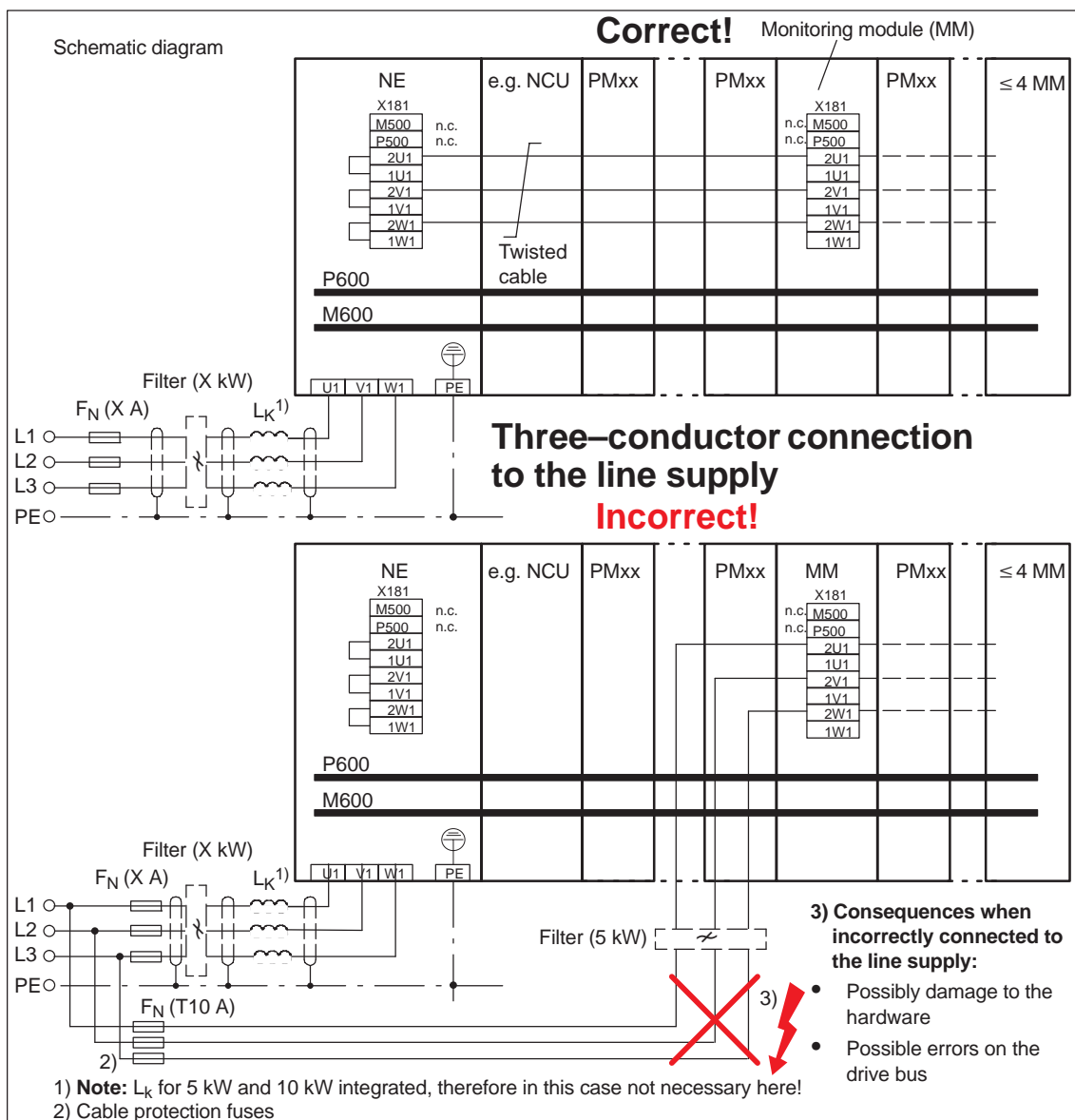

Fig. 8-29 Examples of correctly/incorrectly connecting up the unit using a three-conductor connection with a maximum of four monitoring modules connected to a line infeed module (NE module)

8.15 Examples of correctly and incorrectly connecting NE

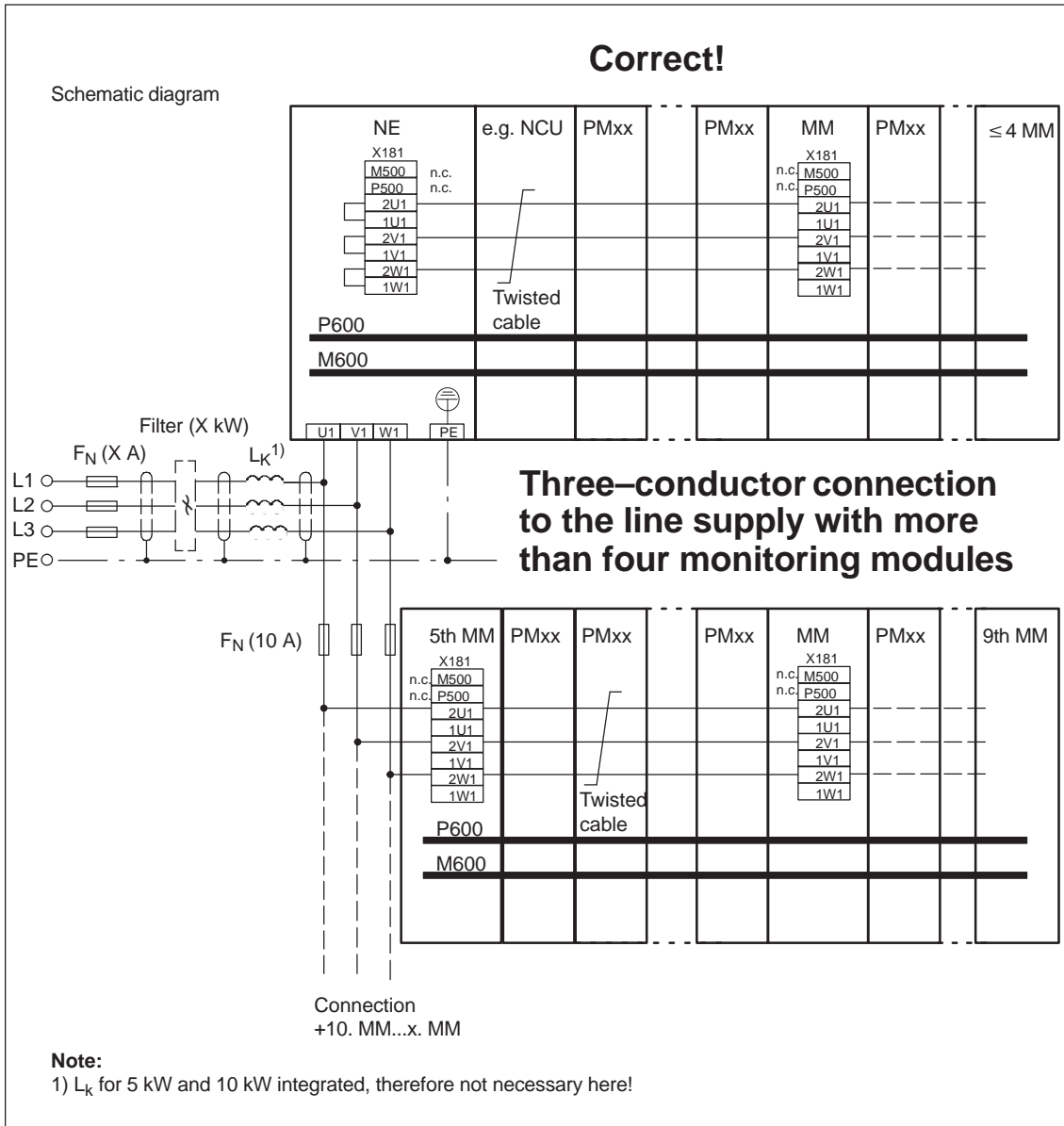

Fig. 8-30 Examples of correctly connecting up the unit using a three-conductor connection for more than four monitoring modules connected to a line infeed module (NE module)

8.15 Examples of correctly and incorrectly connecting NE

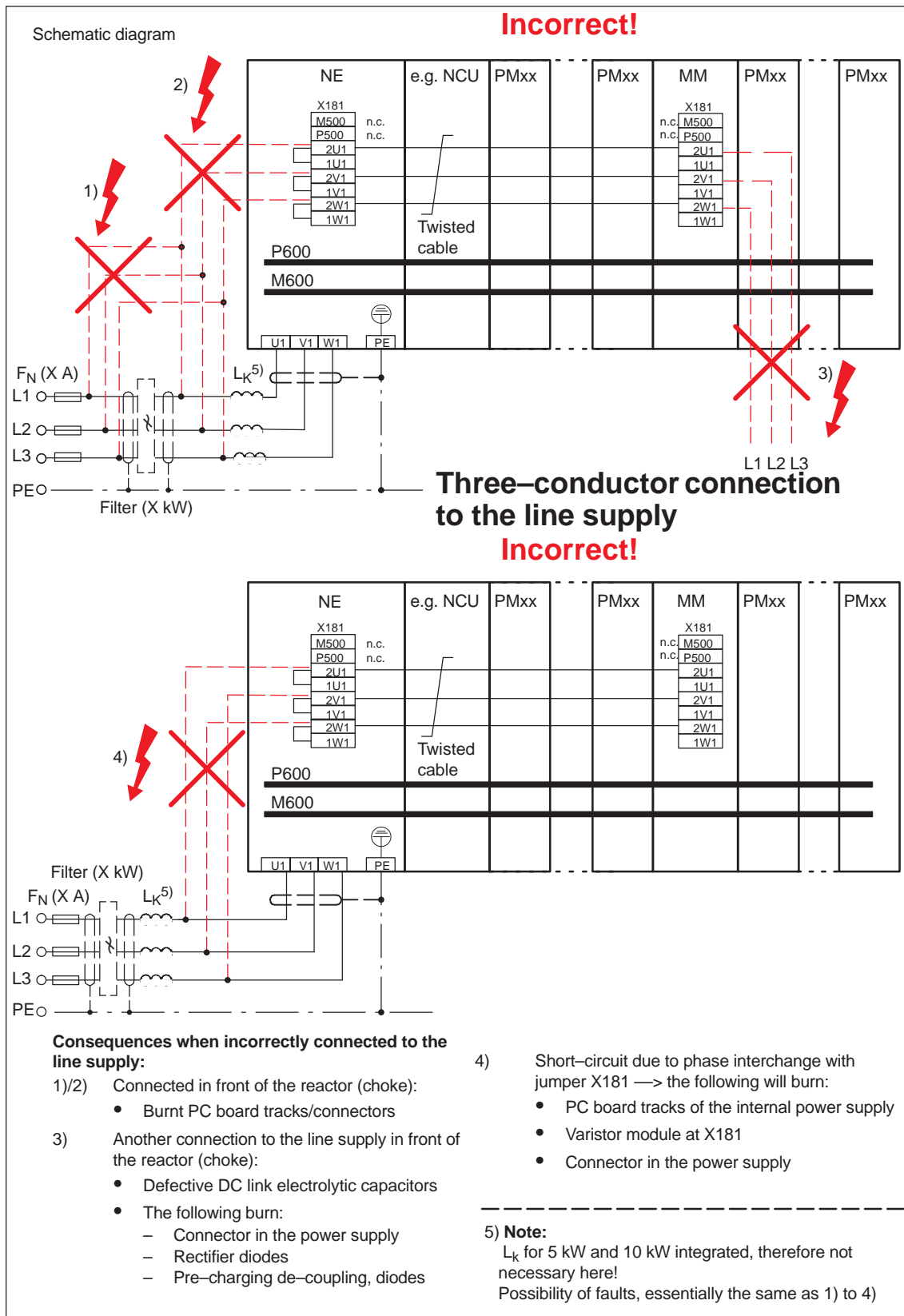

Fig. 8-31 Examples of three-conductor connection to the line supply that are absolutely prohibited

## 8.15 Examples of correctly and incorrectly connecting NE

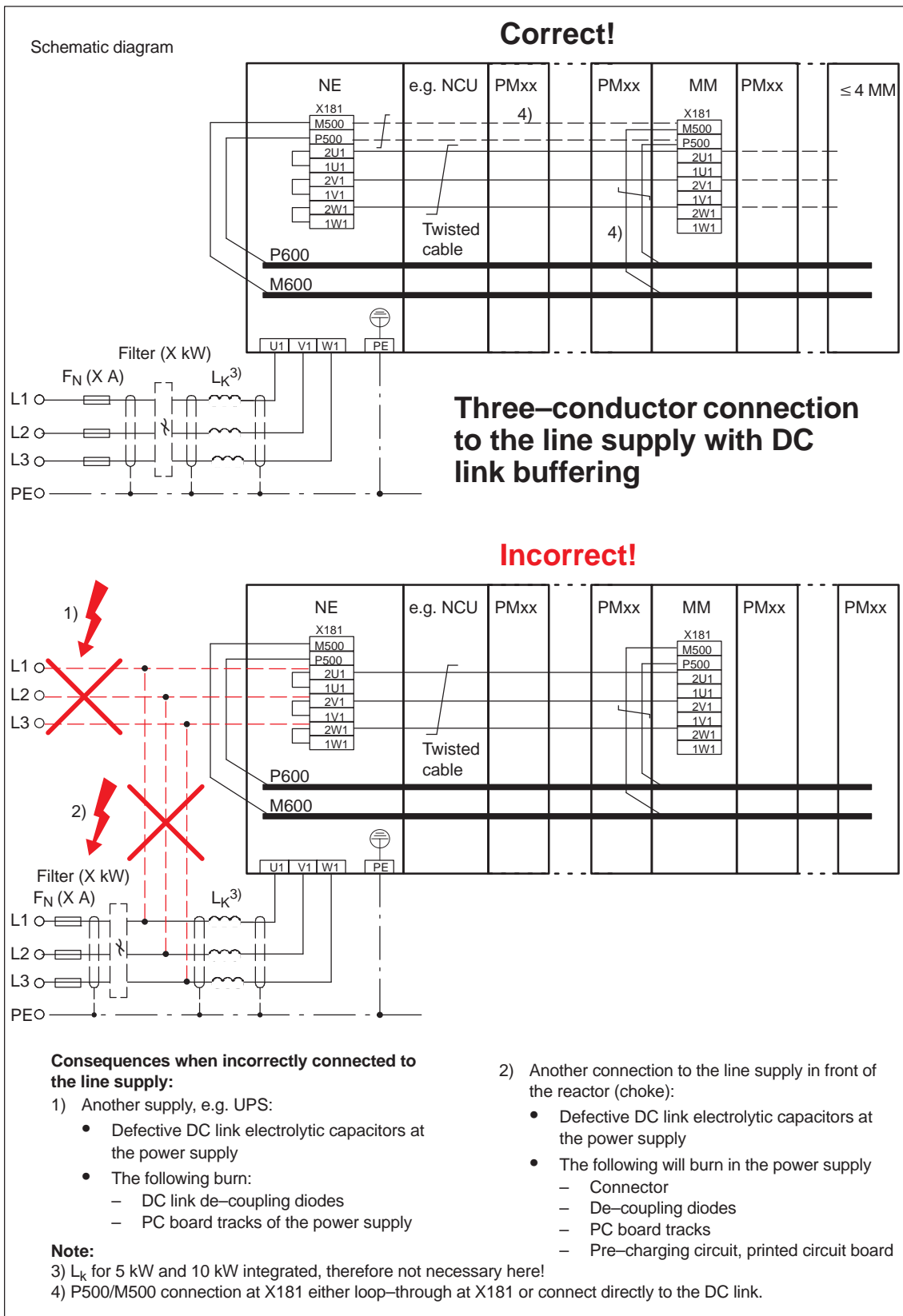

Fig. 8-32 Examples for correct and prohibited three-conductor connection to the line supply + DC link connection

## 8.15 Examples of correctly and incorrectly connecting NE

## 8.15.2 Six-conductor connection to the line supply

**Note**

- All X181 connections of a drive group must be electrically switched in parallel!
- All of the jumpers at X181 must be removed!
- A maximum of four monitoring modules may be connected at X181 of an NE module.
- If a DC link is buffered (DC link connection), the voltage must always be taken from between the reactor ( $L_k$ ) and the line supply infeed (NE).
- Different line supplies may be used, e.g. using UPS.
- For all of the following examples, cables must be routed so that they are short-circuit and ground-fault proof (or fuse)!

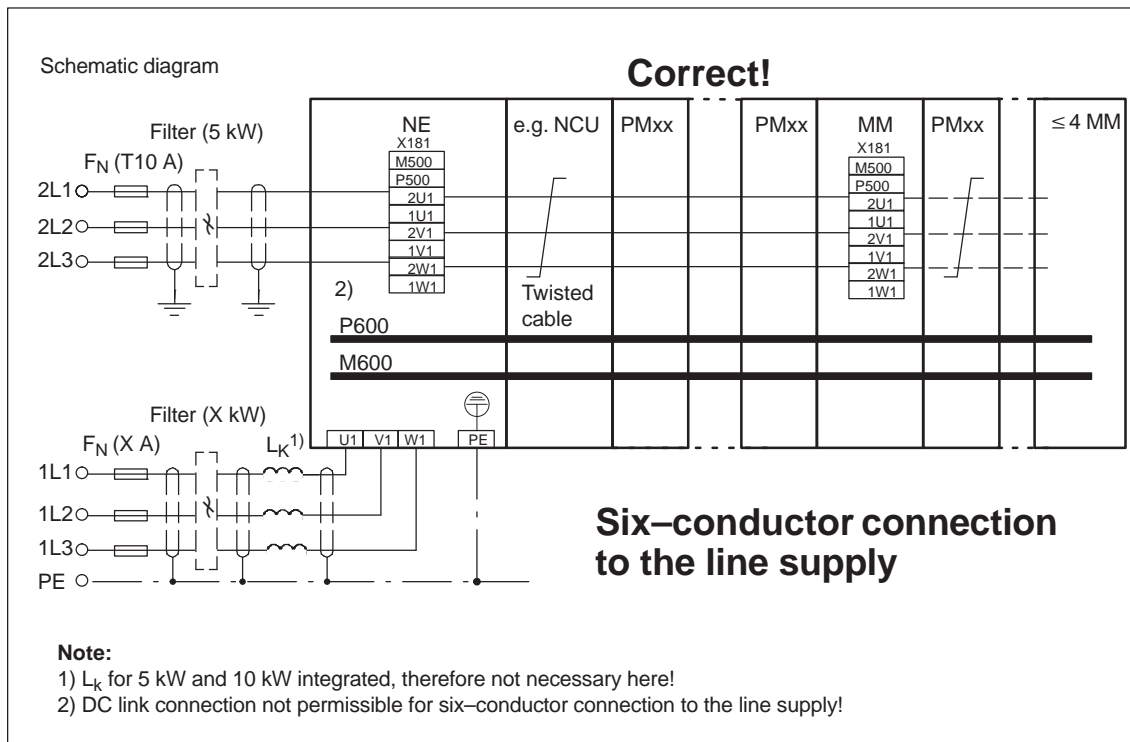

Fig. 8-33 Examples for correct six-conductor connection to the line supply with a maximum of four monitoring modules connected to a line infeed module (NE module)

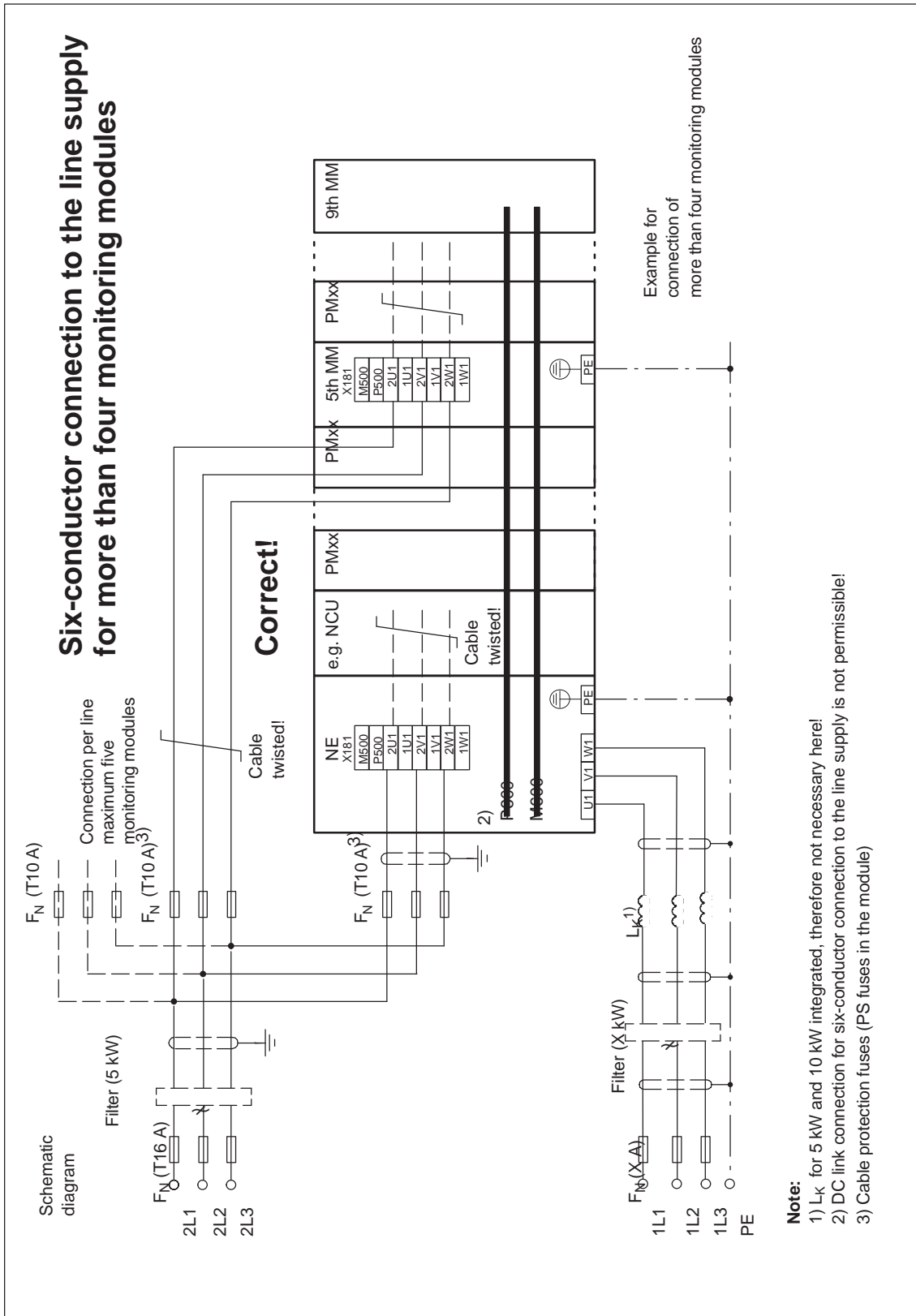

Fig. 8-34 Examples for correct six-conductor connection to the line supply with more than four monitoring modules connected to a line infeed module (NE module)

8.15 Examples of correctly and incorrectly connecting NE

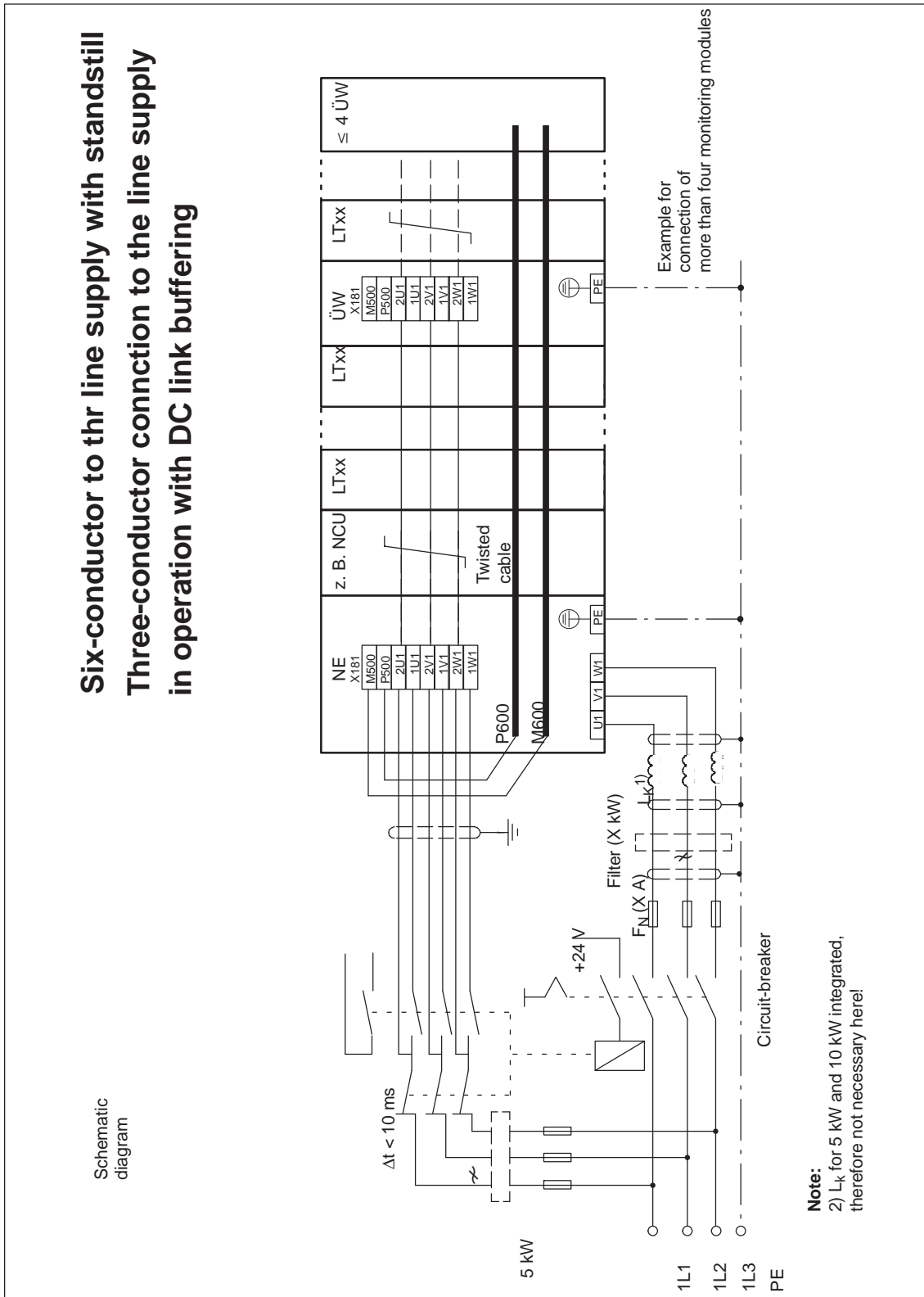

Fig. 8-35 Examples for correct six-conductor connection to the line supply + DC link connection (increase energy efficiency)

8.15 Examples of correctly and incorrectly connecting NE

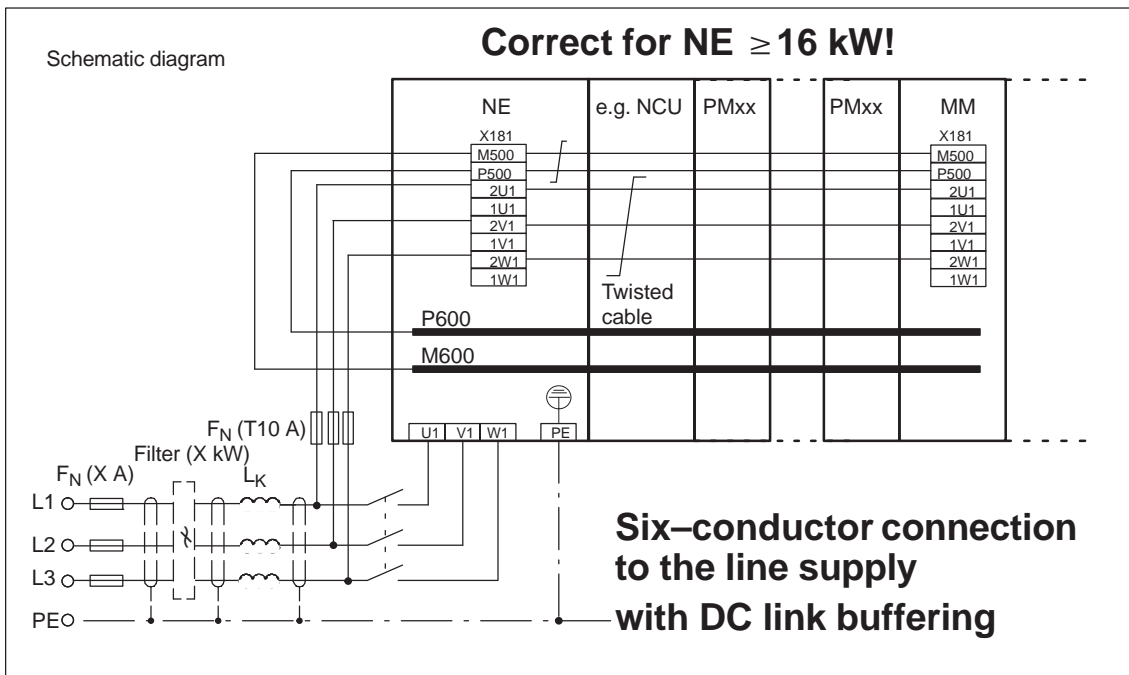

Fig. 8-36 Example for correct six-conductor connection to the line supply + DC link connection



## 8.15 Examples of correctly and incorrectly connecting NE

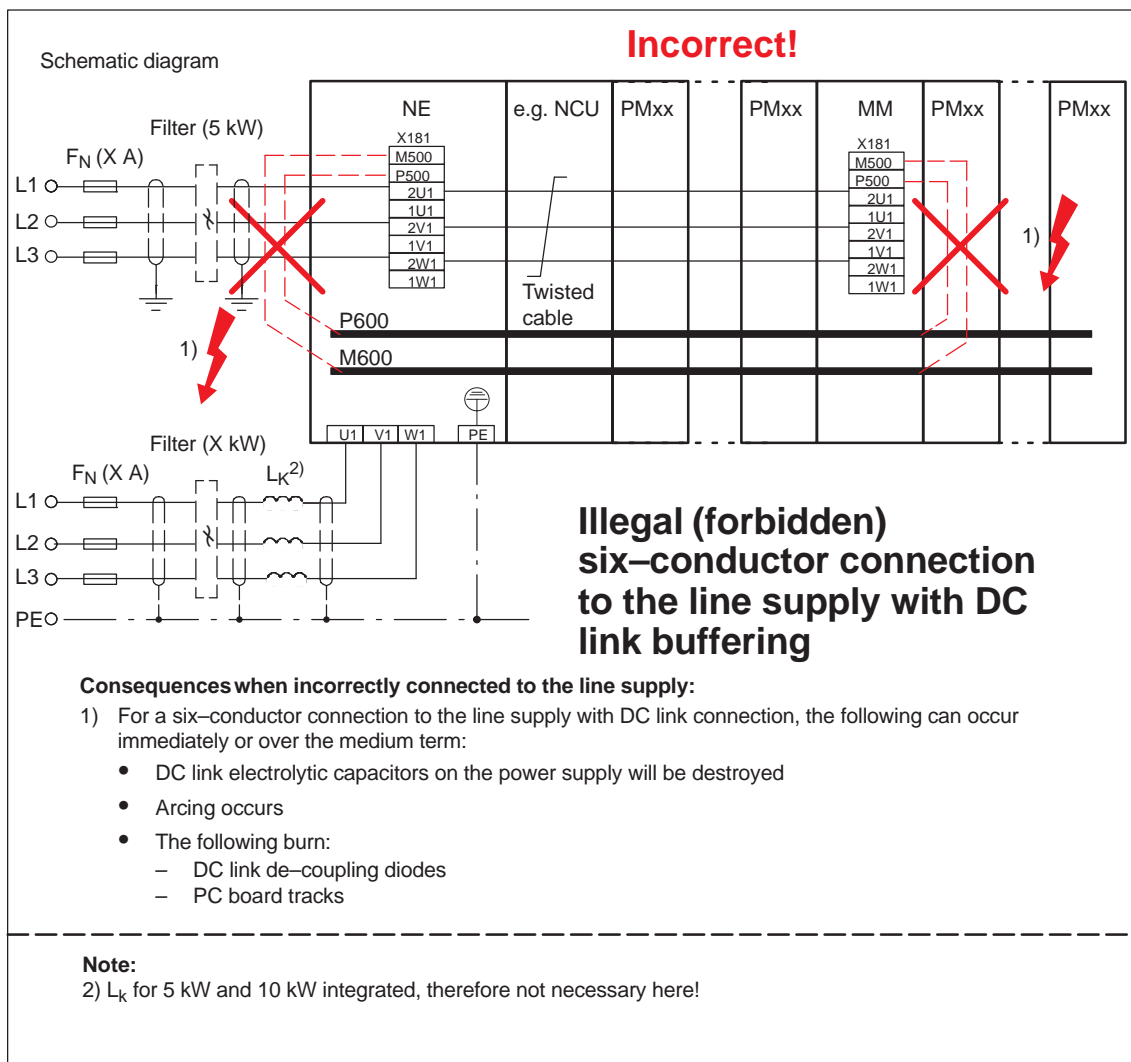

Fig. 8-37 Examples of illegal (forbidden) six-conductor connection to the line supply + DC link connection

## 8.15 Examples of correctly and incorrectly connecting NE

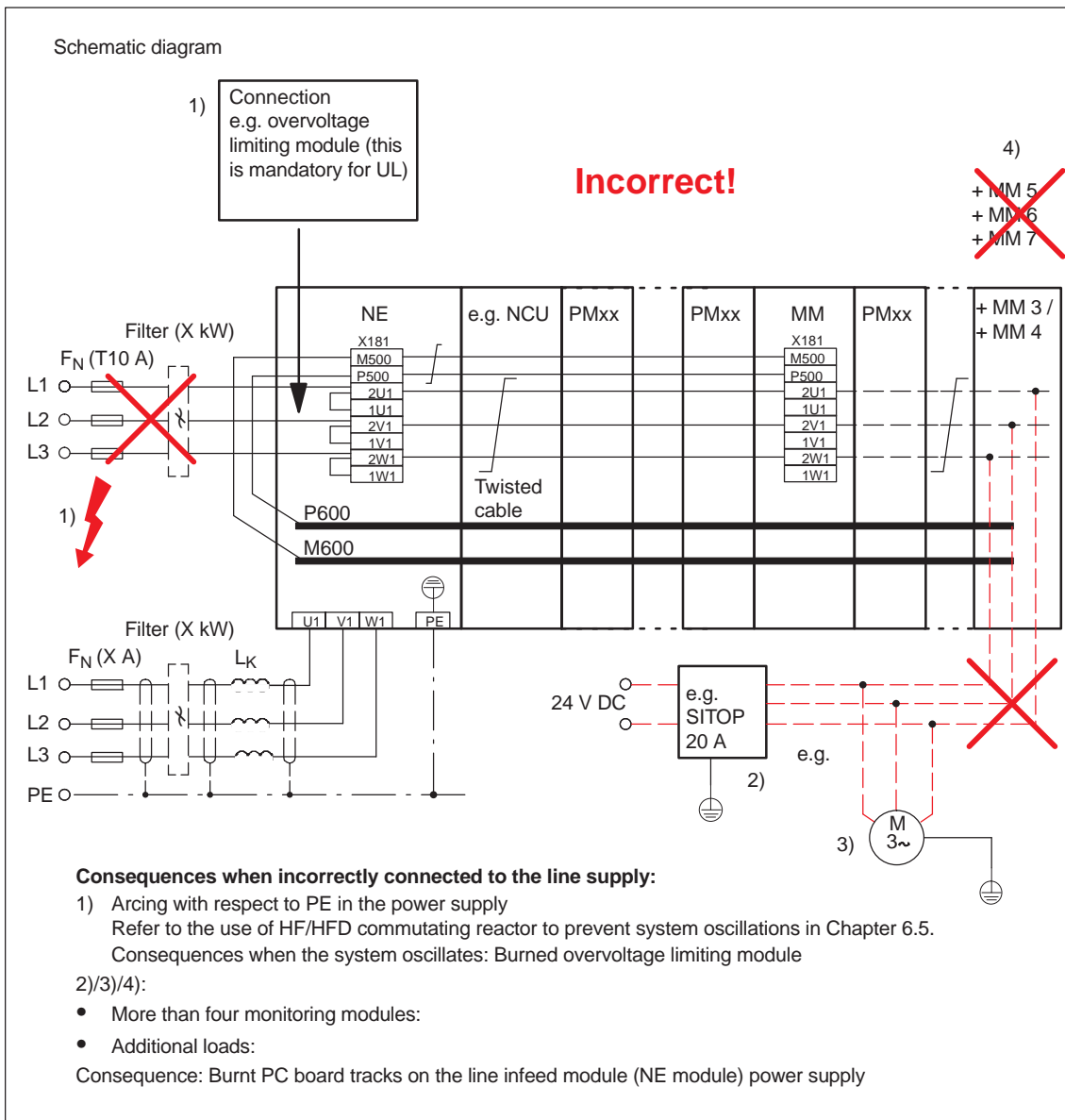

Fig. 8-38 Additional examples for frequent faults/mistakes when connecting to the line supply

## 8.16 VPM Voltage Protection Module

### 8.16.1 General information

The Voltage Protection Module VPM (voltage limiting module) is used for permanent-magnet synchronous motors with an EMF of 800 Vrms up to 2000 Vrms in order to limit the DC link voltage at the converter in the case of a fault. The Voltage Protection Module is connected between the power module and motor in the motor cable. If, at maximum speed, the line voltage fails, or if as a consequence of this, the converter pulses are deleted, the synchronous motor feeds back the full voltage into the DC link.

The VPM identifies an excessively high DC link voltage (> 800 V) and short-circuits the three motor feeder cables. The energy remaining in the motor is converted into heat as a result of the short-circuit between the VPM and the motor feeder cables.

The Voltage Protection Module is available in 3 different versions.

Table 8-4 Overview of the Voltage Protection Modules that are available

Designation	Rated current
VPM 120	120 A
VPM 200	200 A
VPM 200 Dynamik	200 A

When using third-party synchronous motors (generally, with higher inductances than 1FE motors), when combining a third-party synchronous motor with a series reactor as well as the combination of 1FE motor with series reactor, then the VPM 200 Dynamik should be used.

The reason for this is the higher operational inductances and as a consequence, higher voltage rates rise, which can effect of the VPM.

Table 8-5 Interface overview of the Voltage Protection Module

Type	Number of VPM 120/VPM 200	Number of VPM 200 Dynamik
Signal interface	1	1
PE connection	2	4
Load connection studs, input	3	5
Load connection studs, output	3	5

Table 8-6 Technical data VPM

Technical specifications	VPM 120	VPM 200	VPM 200 Dynamik
Order No.:	6SN1113-1AA00-1JA□	6SN1113-1AA00-1KA□	6SN1113-1AA00-1KC□
Type of voltage	3-phase pulsed AC voltage, EMF motor		
Power-up time of the VPM	1 s (from puls enabling)		
Normal range of the DC link voltage			
• lower limit	490 V DC		
• upper limit	795 V DC		
Operating range of the VPM	830 ... 2000 V (peak amplitude)		
Lower limit, DC link voltage	490 V DC		
Inverter clock cycle frequency	3.2...8 kHz		
Rated current	Max. 120 A rms	Max. 200 A rms	
Permissible short-circuit current			
Time range	Maximum	Maximum	
0...10 ms	1500 A	2000 A	
10...500 ms	255 A	600 A	
500...2 min	90 A	200 A	
> 2 min	0 A	0 A	
Permissible rated current	120 s		
Electrical separation	Safe electrical separation between the signaling contact and the motor cables U, V, W according to DIN VDE 0160/pr EN 50178, UL 508		
Degree of protection to EN 60529 (IEC 60529)	IP20		
Permissible humidity	< 90 %		
Humidity classification according to DIN EN 60721-3-3	Cl. 3K5 condensation and formation of ice excluded. Low air temperature 0 °C		
Permiss. ambient temperature			
• Storage and transport	-25...+55 °C		
• Operation	0...+55 °C		
Cooler	Air-cooled, free convection		
Weight	approx. 6 kg	approx. 11 kg	approx. 13 kg
Clearance required on the outside at the sides of the cable glands	200 mm		
Dimensions (W x H x D) [mm]	300 x 150 x 180	300 x 250 x 190	300 x 250 x 260
Connection U, V, W, PE	Screw connection, 8 x M6	Screw connection, 8 x M8	Screw connection, 14 x M8
Torque	10 Nm	25 Nm	25 Nm
Cable cross-section	≤ 50 mm <sup>2</sup>	2 x ≤ 50 mm <sup>2</sup>	2 x ≤ 50 mm <sup>2</sup>
Cable entry	∅ approx. 40 mm	∅ approx. 40 mm	∅ approx. 40 mm
Screwed connection	2 x M50	4 x M50	4 x M50
Conn. X3 (signaling contact)	Terminal, type 226-111 Wago		
Cable cross-section	≤ 1.5 mm <sup>2</sup>		
Cable entry	∅ approx. 9 mm		
Screwed connection	M16		

## 8.16.2 Integration

It must be installed according to the connection schematic VPM 120 (Fig. 8-42) or VPM 200/200 Dynamic (Fig. 8-43).

Series reactors may only be connected between the VPM and motor.

Clearances of approx. 200 mm must be provided above and below the unit for cable entry.

It can be mounted in any position.

It is not permissible that switching elements are inserted in the connecting cables U, V, W between the drive, VPM and motor!

The air intake temperature, measured 10 mm below the unit, may not exceed 55 °C.

---

### Caution

After switching off all of the voltages, hazardous voltages are present for up to 4 minutes (capacitance of the 611 converter capacitor). The voltage must be measured to ensure that there are no hazardous voltages present!

---



---

### Notice

The unit is a safety-relevant piece of equipment and may only be used as specified. Other application, e.g. armature short-circuit in operation and others are not permissible.

The warning information on the unit must be carefully observed!

Operation with VPM is only permitted in conjunction with the SIMODRIVE 611 digital, SIMODRIVE 611 universal, converter system, **shielded Motion-Connect 800 motor supply cables**, and **enabled** permanent-magnet induction motors.

---



---

### Warning

Motors with an EMF that can achieve a DC link voltage > 2 kV (EMF = 1.4 kV eff) at the highest speed are not permitted to be connected to the SIMODRIVE 611. In this case, the insulating voltage could be exceeded, resulting in personal injury due to electric shock.

Voltages  $U \leq 2$  kV can occur at cables/conductors that are cut or damaged.

In the event of an error, the terminal voltage of the permanent-magnet induction motors can assume values  $U \leq 2$  kV.

Hazardous voltage is still present approximately 4 minutes after all voltages have been shut down (capacitor capacity of the SIMODRIVE 611 converter). In order to ensure that no hazardous voltages are present, the voltage must first be measured.

---

**Interface  
description**

Die folgenden Zeichnungen zeigen die prinzipielle Lage der Schnittstellen und der Gehäusedurchlässe der Voltage Protection Modules VPM 120, VPM 200 und VPM 200 Dynamik.

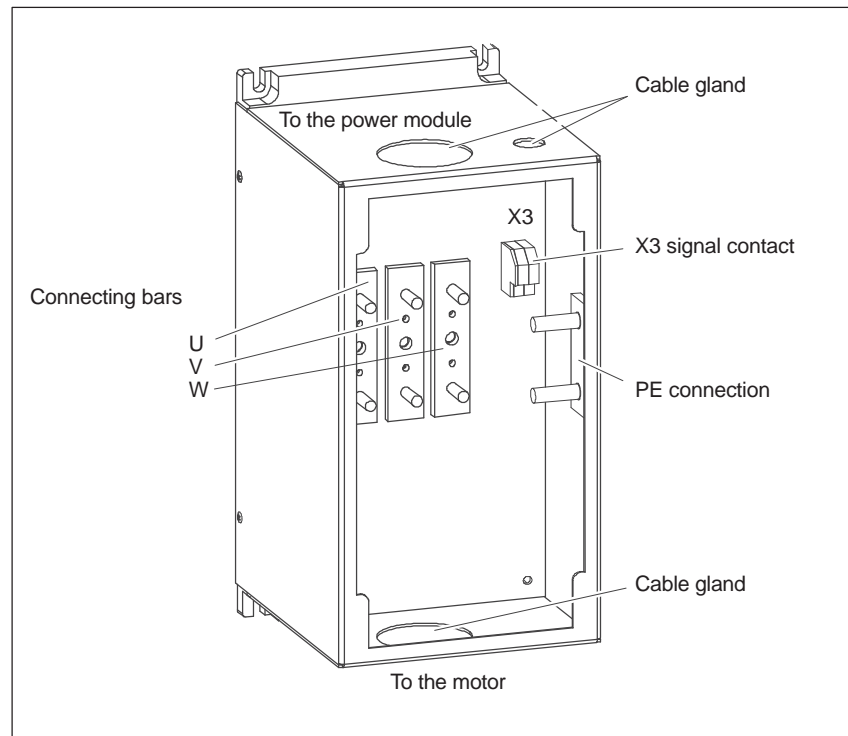

Fig. 8-39 Voltage Protection Modules VPM 120 (without cover)

8.16 VPM Voltage Protection Module

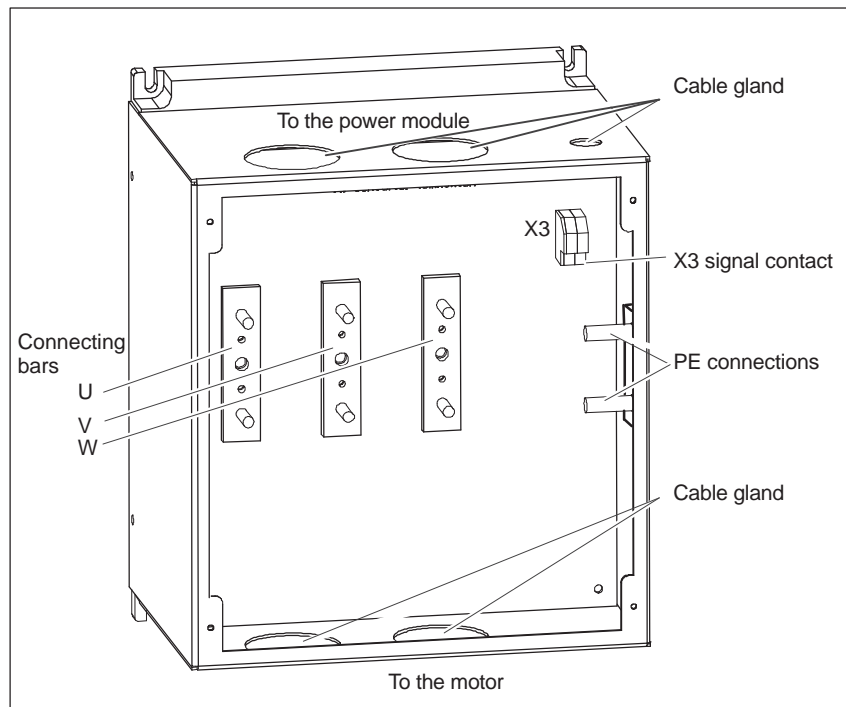

Fig. 8-40 Voltage Protection Modules VPM 200 (without cover)

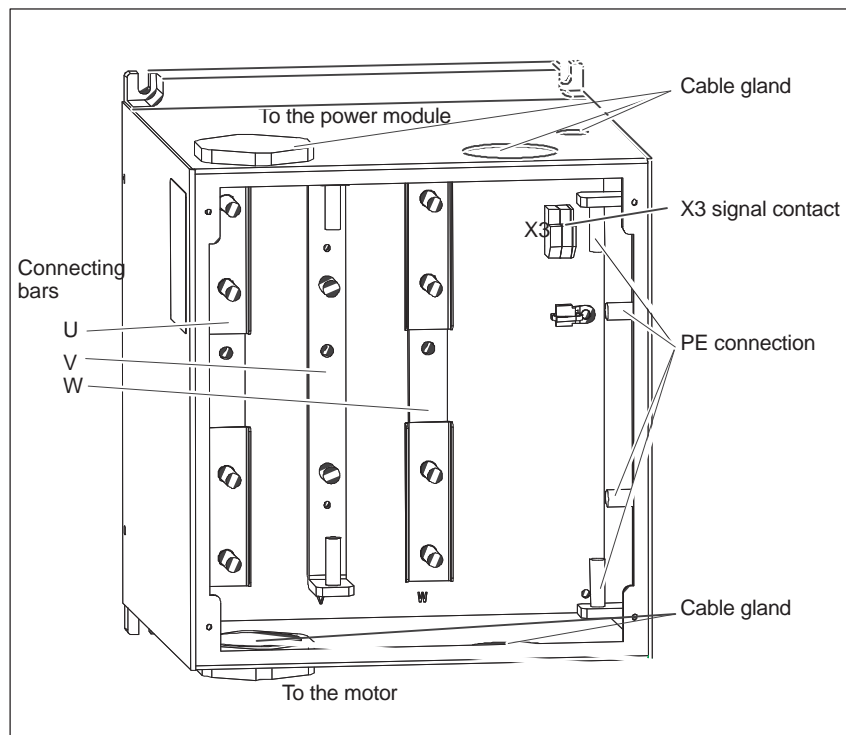

Fig. 8-41 Voltage Protection Modules VPM 200 Dynamik (without cover)

In operation, the housing is closed so that the electrical connection points are covered.

**Connection,  
VPM 120**

For the power connections to the power module and for the motor, the cables are routed through the cable glands of the Voltage Protection Module and connected to the connecting bars inside the device.

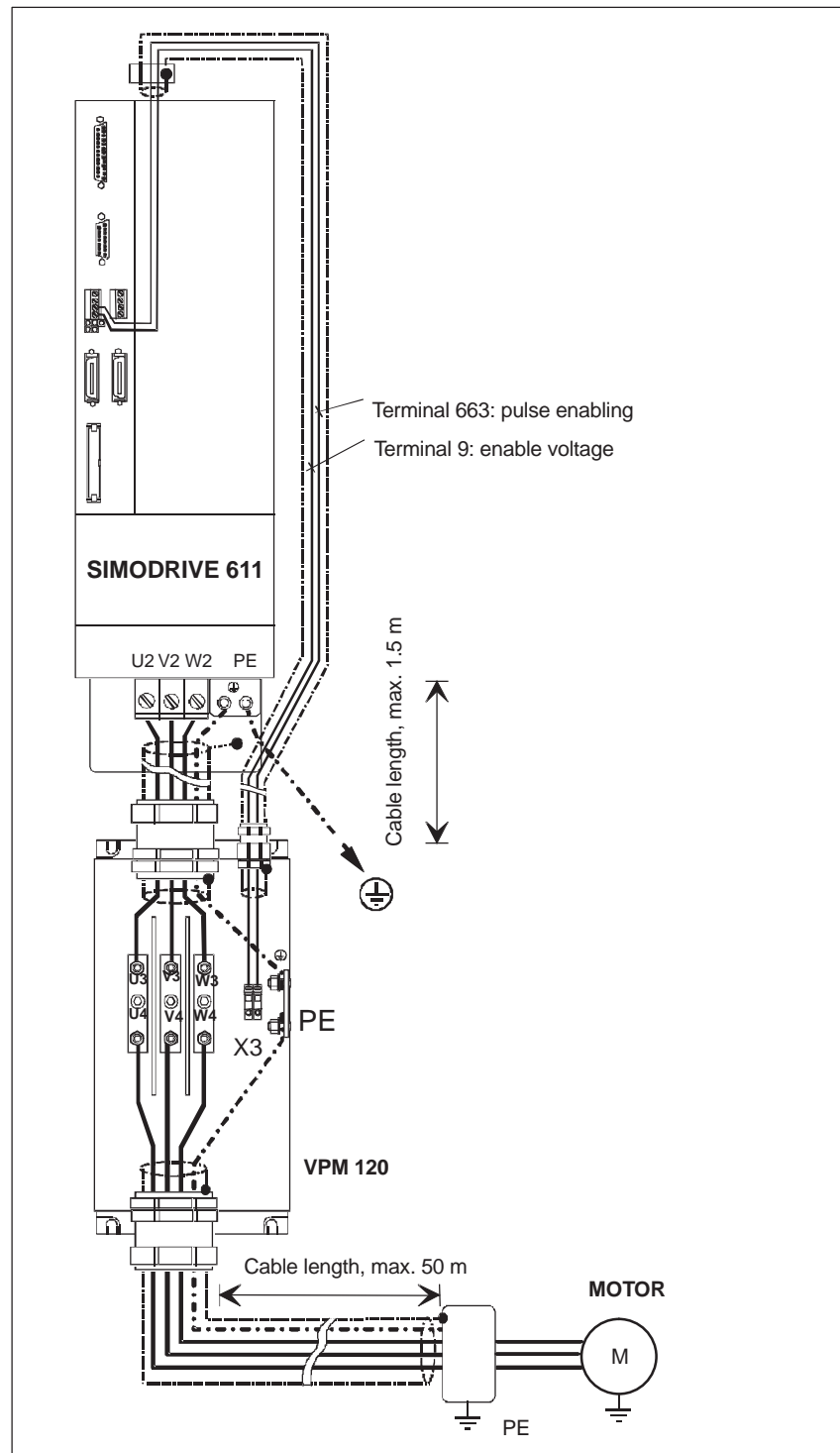

Fig. 8-42 Connection, VPM 120



## 8.16 VPM Voltage Protection Module

**Connection**  
**VPM 200/**  
**VPM 200 Dynamik**

For the power connections to the power module and for the motor, the cables are routed through the cable glands of the Voltage Protection Module and connected to the connecting bars inside the device.

- Wiring diagram

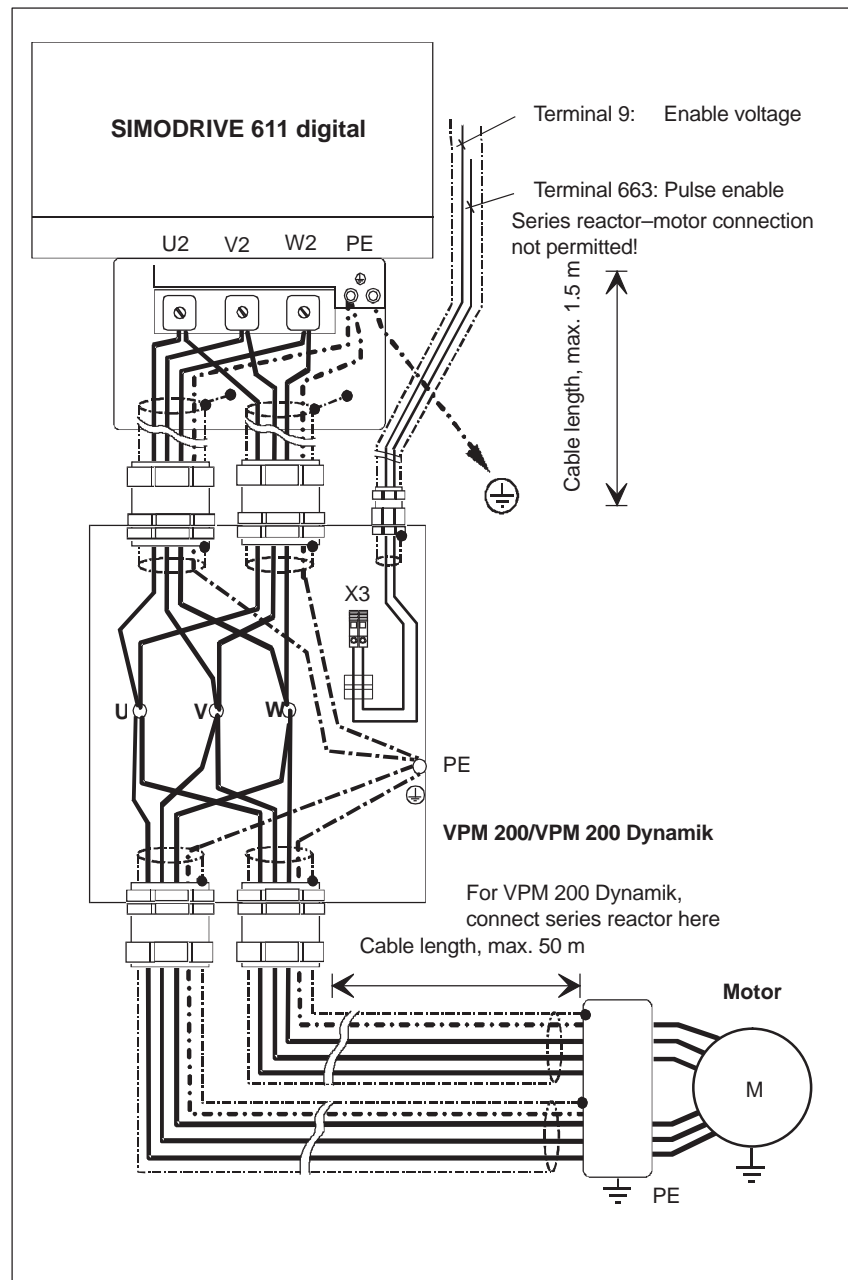

Fig. 8-43 Connection VPM 200/VPM 200 Dynamik

- Connection of internal cable routing and VPM 200 Dynamik

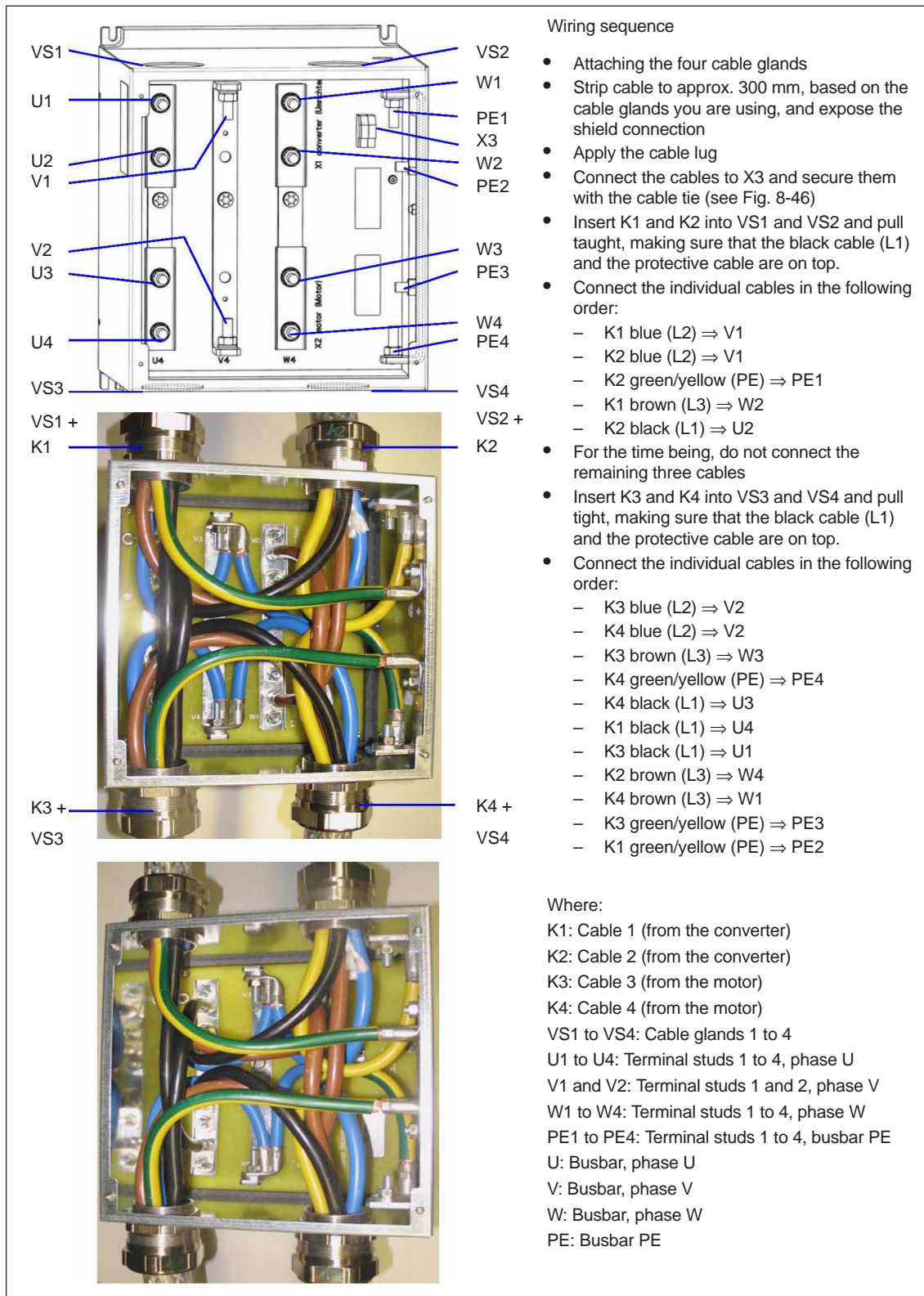

Fig. 8-44 Connection of internal cable routing and VPM 200 Dynamik

## 8.16 VPM Voltage Protection Module

**Signal contact X3**

When the VPM is tripped or in the event of a temperature fault, signaling contact X3 opens and interrupts the pulse enable of the SIMODRIVE converter (see Fig. 8-45).

**Warning**

The signaling contact X3 closes autonomously after  $t > 2$  min or after the temperature switch has been reset. Therefore, measures must be adopted to prevent the drive from starting by itself!

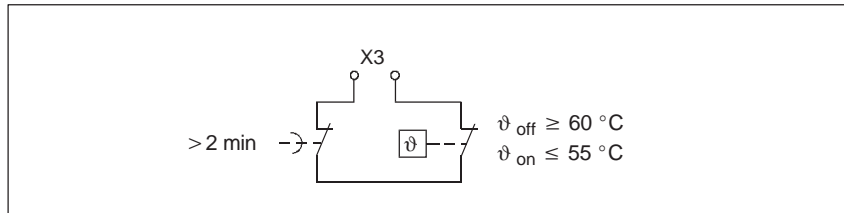

Fig. 8-45 Signaling contact X3 of the VPM

Table 8-7 Technical data, signaling contact X3

Designation	Technical specifications
Contact 1. Operating message 2. Operating voltage +24 V (from external)	NC contact, floating
Switch rating	30 V DC at 0.1 A
Switching voltage/switching current	min 19 V/10 mA
Interrupts when the housing temperature	$\geq 80 \pm 2.5$ °C
Switches back	$\leq 55$ °C
Interruption time after the start of short-circuit operation	> 2 min Note: This value is valid 15 s after the drive and pulse enable
Terminal type: Spring loaded terminal WAGO, type 226-111, cable cross-section max.: 1,5 mm <sup>2</sup> , shielded cable	
Cable gland: max. 9 mm Ø. Types VPM 120, VPM 200 and VPM 200 Dynamik	
<ul style="list-style-type: none"> <li>Screwed connection: 1 x M16, z. B. Fa. Pflitsch, Order No.: UNI DICHT EMV 2165211S05</li> <li>counter nut: M16: GM216PA.</li> </ul>	

**Caution**

When a VPM is tripped, the short-circuit thyristor must be safely cleared before the connected drive can be switched on again. This is only ensured if the motor has first come to a standstill.

An X3 signal contact that has closed again is **not an explicit indication** that this has occurred.

Be especially cautious of this in the event of servicing.

---

**Note**

Signal contact X3 of the VPM is routed via a bistable relay. Very significant shocks that occur during transport and installation can cause the relay to go into the other switching state. As a consequence, it cannot be guaranteed that the system will start.

To resolve the fault:

1. Connect terminal 9 and terminal 663 (pulse enable)
  2. Switch-on SIMODRIVE 611D
  3. Allow the spindle to rotate at an average speed for at least 2 seconds
  4. Switch-off SIMODRIVE 611D; the relay is reset when the internal 24 V supply is switched off
  5. Remove the jumper between terminal 9 and terminal 663
- 

**Cable lengths**

The maximum length of the power cable between the power module and Voltage Protection Module is 1.5 m. It is not permissible that this module includes any switching elements.

The power cable between the Voltage Protection Module and the motor must not exceed a length of 50 m.

The maximum length of the signal cable is 10 m.

### Connecting the X3 signaling contact

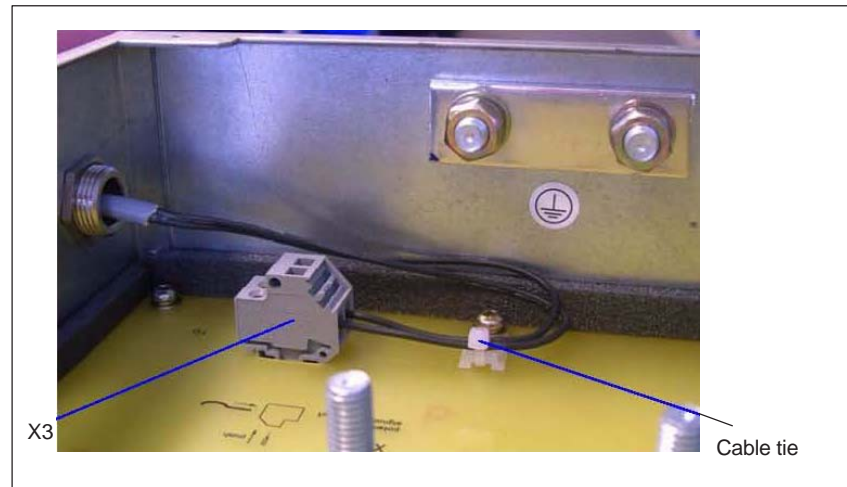

Fig. 8-46 Connecting the X3 signaling contact for VPM 200 and VPM 200 Dynamik

To check the function of the VPM, operate the motor at a speed for which the EMC of the motor would be approx. 650 V eff. An oscilloscope is used to measure the motor voltage. This requires that a pulse inhibit is initiated on the converter system and on the I/R unit. When the VPM is activated, the motor voltage must fall to just a few volts, if not, the VPM is defect!

#### Note

To measure the EMC:

Perform the measurement with the oscilloscope. For the measurement, either potential-separate active voltage dividers for high voltages or passive probes explicitly suitable for voltages above 1.5 kV must be used. Multimeters, also not effective value multimeters, cannot be used.

No standard probes may be used for the oscilloscope measurement. For measurement with passive probe, the ground clip must be set to ground, under no circumstances to the converter terminal. Then use the oscilloscope to subtract two channels, e.g. U voltage to ground and V voltage to ground, from each other and display the result on the screen.

## 8.16.3 Mounting

The Voltage Protection Module is mounted in the cabinet close to the drive.

**Danger**

It is only permissible to connect motor reactors between the Voltage Protection Module and the motor.

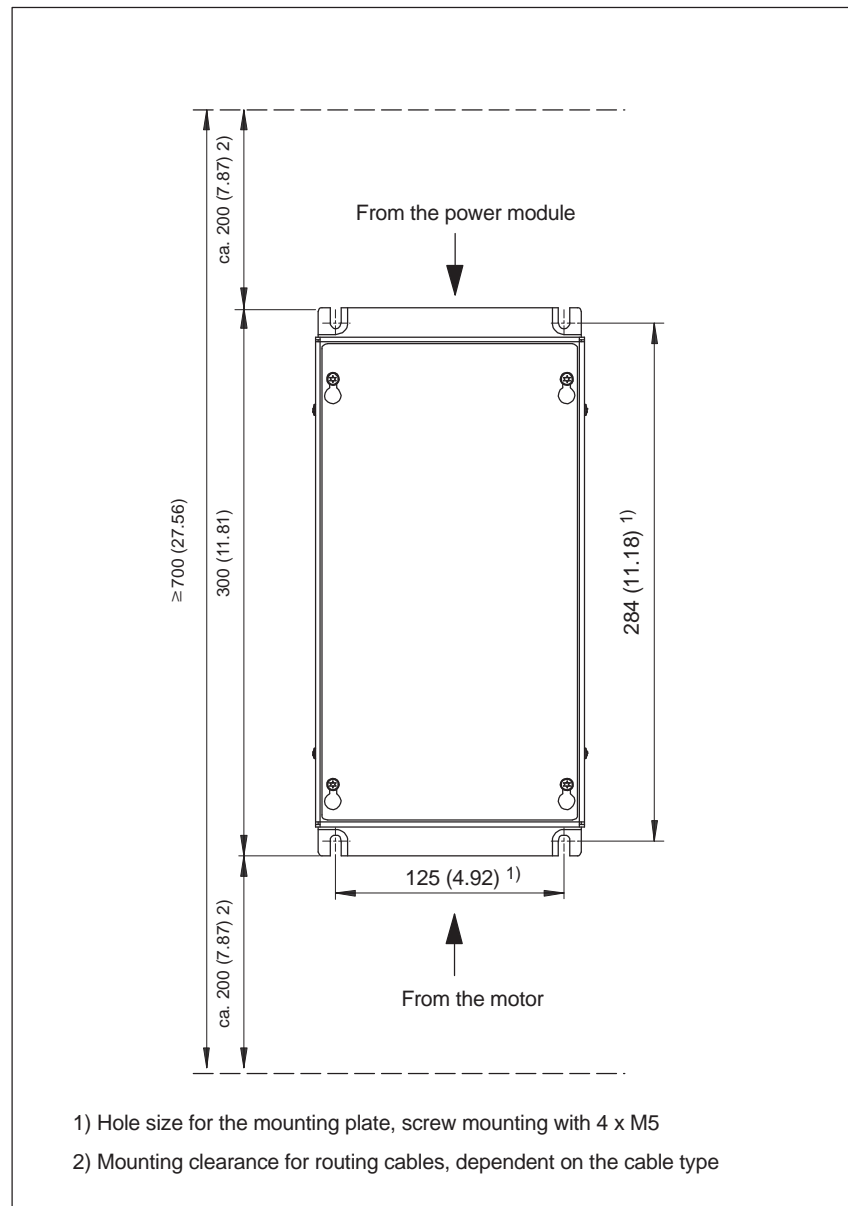

Fig. 8-47 Mounting dimensions for a Voltage Protection Module VPM120

## 8.16 VPM Voltage Protection Module

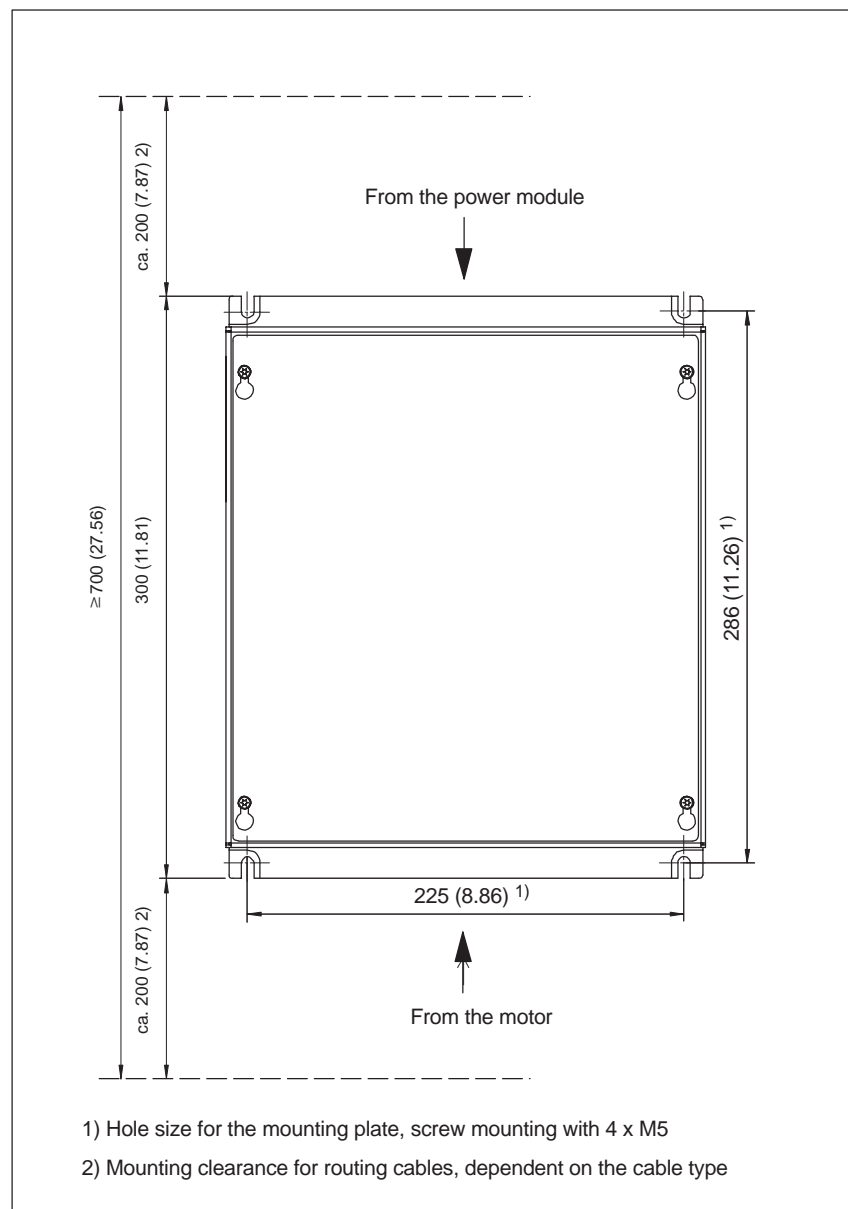

Fig. 8-48 Mounting dimensions for a Voltage Protection Module VPM200



## 9.1 Installation and connecting-up regulations

---

### Note

The "SINUMERIK, SIROTEC, SIMODRIVE, SINAMICS S120 EMC Directive" (Order No.: 6FC5297-0AD30-0AP□) must always be observed; refer to the documentation overview on the cover page.

Chapter 9 contains only product-specific additions!

---



---

### Caution

Carefully ensure that the line filter is connected to the line supply in-line with the specifications/regulations:

LINE L1, L2, L3 for line filters for the UI module and I/R module for sinusoidal current mode.

If this is not observed, the line filter could be damaged. Also refer to the connection diagram 9-1.

---

---

### Caution

The line filters listed conduct a high leakage current over the PE conductor. A permanent PE connection for the filter or control cabinet is required due to the high leakage current of the line filters.

Measures according to EN 50178/94 Part 5.3.2.1 must be taken, e.g. a PE conductor ( $\geq 10 \text{ mm}^2 \text{ Cu}$ ) or a second conductor must be routed electrically parallel to the PE conductor via separate terminals. This conductor must also fully meet the requirements for PE conductors according to IEC 60364-5-543.

---

### Applications

The line filters described have been dimensioned to suppress SIMODRIVE 611 drive converters; they have not been designed to suppress (noise/interference suppression) other loads in the electrical cabinet. A dedicated filter must be provided for other loads in the electrical cabinet.

If the electronics power supply is connected to a separate line supply, then the feeder cable must be routed through a second filter. The feeder cable to the electronics power supply (connector X181) must be shielded and the shield must be connected at both ends at the connector side as close as possible to connector X181 – on the cabinet mounting panel.

The line supply connection for fan units must also be routed through a second filter.



## 9.1 Installation and connecting-up regulations

**Mounting in the electrical cabinet**

The line filter must be located in the same cabinet field close to the NE modules; the cable (shielded above 1 m) connecting the line filter to the NE module should be kept as short as possible. The incoming and outgoing cables to/from the line filter must be routed separately from one another.

Recommended configuration, refer to Fig. 9-1.

**Note**

If the system is subject to a high-voltage test using AC voltage, a line filter must be disconnected in order to obtain a correct measurement result.

**Connection cable shield**

A permanent strain relief for the cables must be present. These cables must not pass strain forces to the cable shielding!

Shield connecting plates with a clamp connection are provided on the NE and PM modules to connect the shields of shielded powered cables; mounting locations are also provided for brake terminals (Order No., refer to Table 9-1. Also refer to the dimension drawing "EMC measures", Chapter 12).

Table 9-1 Order Nos. for the shield connecting plates

Module width [mm]	Shield connecting plate for modules with	
	internal cooling 6SN1162-0EA00	external cooling 6SN1162-0EB00
50	-0AA0	-0AA0
100	-0BA0	-0BA0
150	-0CA0	-0CA0
200	-0JA0	-0JA0
300	-0DA0	-0DA0
300 for fan/hose	-0KA0	—————

If the motor is equipped with a brake, then the shield of the brake feeder cable must be connected at both ends to the shield of the power cable.

If there is no possibility of connecting a shield on the motor side, a gland must be incorporated in the terminal box with the possibility of establishing a shield-motor connection through the largest possible surface area.

**Warning**

Cable shields and cores/conductors of power cables which are not used, e.g. brake conductors, must be connected to PE potential in order to discharge charges arising from capacitive coupling.

Non-observance can cause lethal shock voltages.

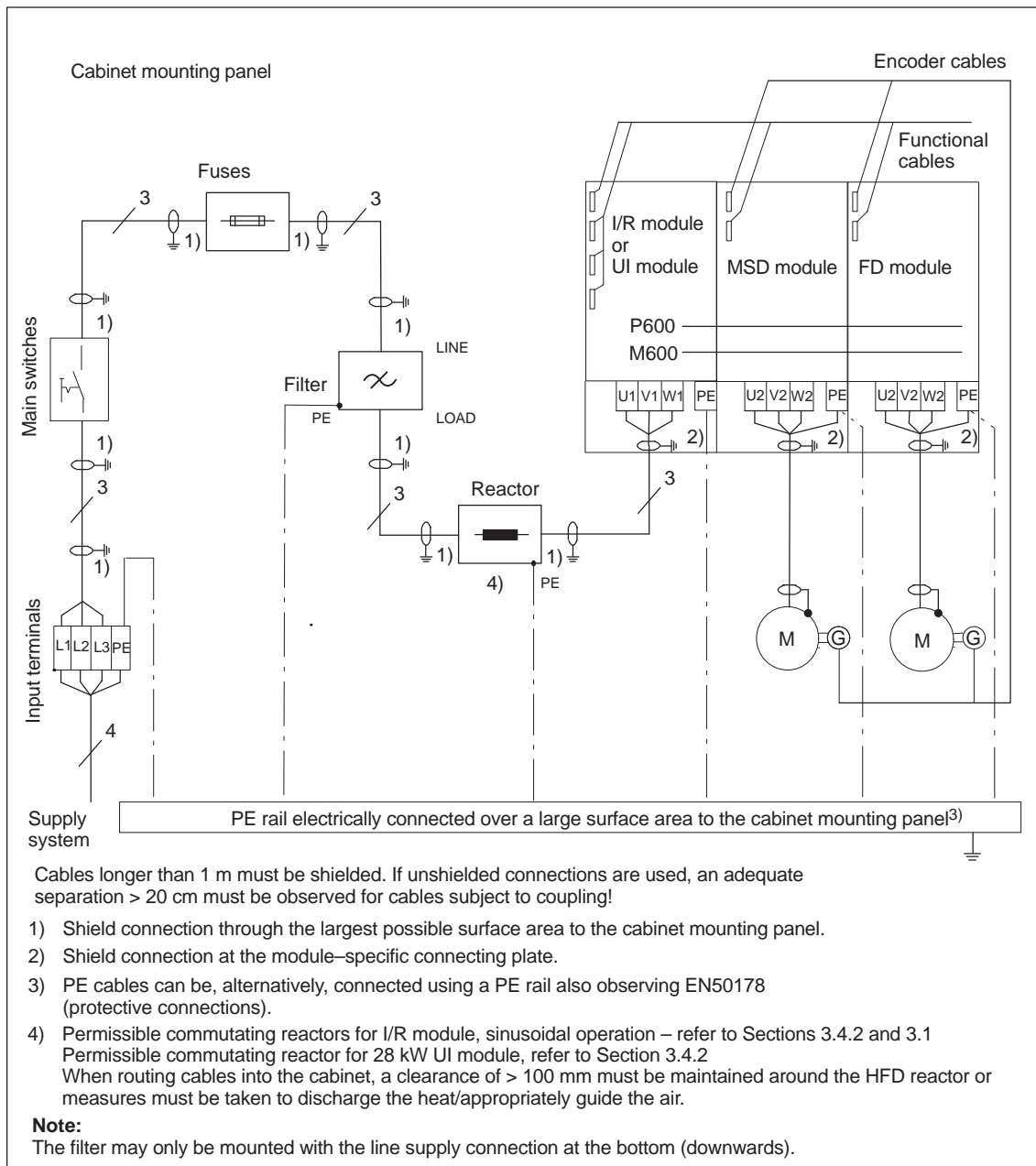

Fig. 9-1 Connecting diagram for line filters for 5 kW and 10 kW U/I modules and for 16 kW to 120 kW I/R modules. The connecting diagram also applies to ~28 kW UI, – however as a result of the unregulated infeed, 6-pulse squarewave current is drawn.

### Note

1. The EMC measures described above ensure CE compliance with the EMC Directive.
2. Alternative measures can be applied, e.g. routing behind mounting plates, suitable clearances, under the assumption that they have similar results.
3. This excludes measures that relate to the design, installation, and routing of motor power cables and signal cables.

## 9.1 Installation and connecting-up regulations

## 9.1.1 Shielded connecting plates

Shield connecting plates are available that can be retrofitted for the infeed and power modules. These plates also have mounting points for brake connecting terminals.

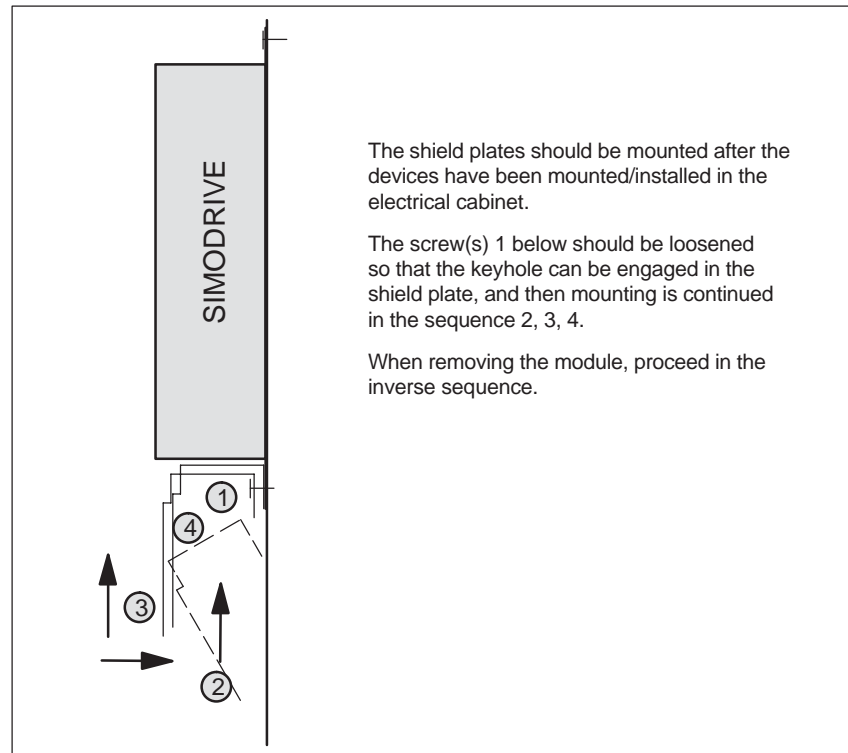

Fig. 9-2 Mounting the shielding plate

### Shield connection cables

The shield connection is used to ensure that cables for electronics, e.g. incremental shaft-angle encoders for SIMODRIVE 611 universal HRS, are connected to the ground potential of the module housing in compliance with EMC (for Siemens encoder cables, the shield is connected in the encoder connector). The shield connection is mounted above the control units using the screws supplied above the threaded sockets at the power modules.

Order No. (MLFB): 6SN1162-0FA00-0AA□

#### Note

For SIMODRIVE 611, the 6SN1162-0FA00-0AA2 shield connection can be used for in-house assembled sensor lines, e.g. for TTL encoder to SIMODRIVE 611 universal.

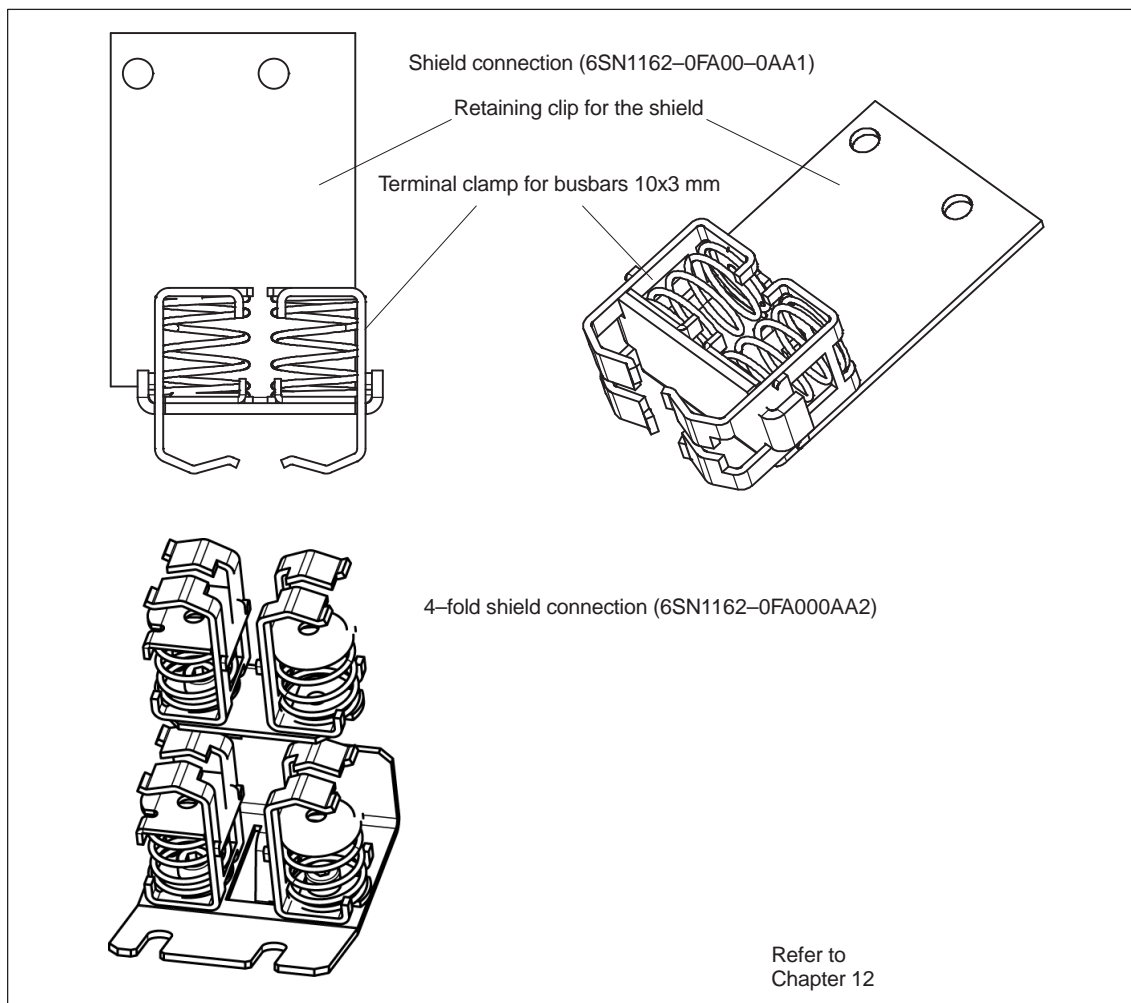

Fig. 9-3 Shield connection 6SN1162-0FA00-0AA1

The shields of original pre-assembled cables are automatically connected when the cable is plugged-in.

Exceptions:

- Setpoint cable from the analog NC  
Here, the shields of the setpoint pairs must be connected to the upper side of the module. The threaded sockets provided can be used for this purpose (M5x10/3 Nm).
- Drive bus cable from SINUMERIK 840C  
Here, the shield is connected to the threaded socket mentioned above using the clamp provided.
- Drive bus and equipment bus extension cables for 2-tier configurations.  
Here, shields are connected at both ends of the cables to the above mentioned threaded sockets using the clamps provided.
- Motor power cables  
The shields of the motor feeder cables are connected, using the hose connectors provided, to the shield connecting plates (accessories) of the modules.

#### Shield connection front panel

In order to ensure a good connection between the front panel and the housing, the screws at the front panel must be tightened with a torque of 0.8 Nm.

---

9.1 Installation and connecting-up regulations

<b>Connection, electronics ground</b>	Terminal X131 (electronics ground) at the NC.
<b>Protection against overvoltages</b>	In order to provide protection against overvoltage (for line supplies that are not in compliance with VDE), an overvoltage limiter module (Order No.: 6SN1111-0AB00-0AA0) can be inserted at connector X181 on the NE module (this is not necessary for UI 5 kW and monitoring module).
<b>Maximum cable lengths</b>	<p>Using non-shielded signal and direct current supply cables (e.g. 24 V infeed with external supply):</p> <ul style="list-style-type: none"><li>• DC power supply cables: Length <math>\leq</math> 9.90 m permissible.</li><li>• Non-shielded signal cables: Length, max. 30 m permissible without any additional circuitry</li></ul> <p>For longer lengths, the user <b>must</b> connect suitable circuitry to provide overvoltage protection, e.g. the following type:</p> <p>TERMITRAB-UK5/ 24DC Article no. 27 94 69 9 from Fa. Phoenix Contact GmbH &amp; Co 32823 Blomberg, Germany Tel. +49 (0)5235/300 Fax +49 (0)5235/341200 <a href="http://www.phoenixcontact.com">http://www.phoenixcontact.com</a></p>

---

**Note**

We recommend that prefabricated cables are used, as correct shielding is necessary to ensure an EMC-safe connection.

Further, the appropriate cable parameters are required in order to ensure optimum signal transfer characteristics. The function will only be guaranteed when using the original cables.

**Reference:** /EMC/ EMC Configuring Guidelines  
SINUMERIK, SIROTEC, SIMODRIVE

---

### 9.1.2 Mounting conditions, internal cooling

#### Note

The regulations described in the "SINAMICS S120 Booksize / SIMODRIVE System Manual" switchgear cabinet integration system manual Order No.: 6SL3097-0AT00-0AP□ must be observed for the heat dissipation!

#### General information

If the guidelines for installing/mounting SIMODRIVE 611 equipment in the cabinet are not carefully observed, this can significantly reduce the service life of the equipment and result in premature component failure.

The following specifications must be carefully observed when mounting/installing a SIMODRIVE 611 drive group:

- Cooling clearance
- Cable routing
- Air flow, climate-control equipment

**Cooling clearance** Minimum 100 mm clearance at the top and bottom for cooling.

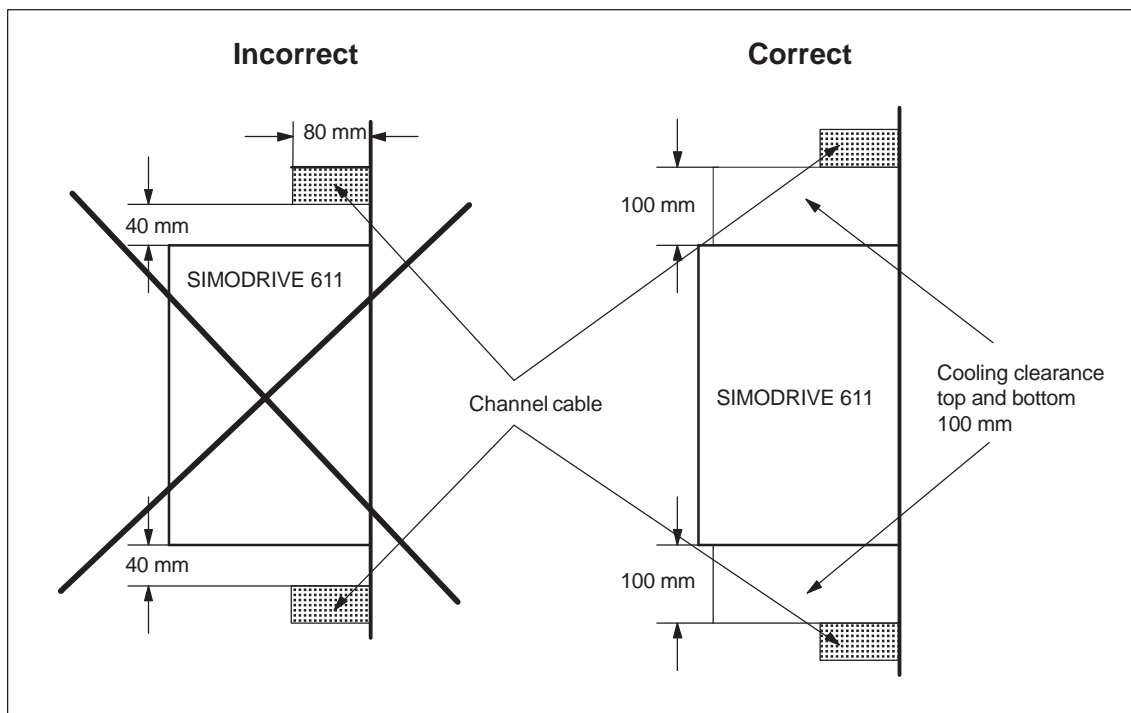

Fig. 9-4 Cooling clearance

Air intake temperature, max 40 °C, at higher temperatures (max 55 °C), the power must be reduced (derating).

## 9.1 Installation and connecting-up regulations

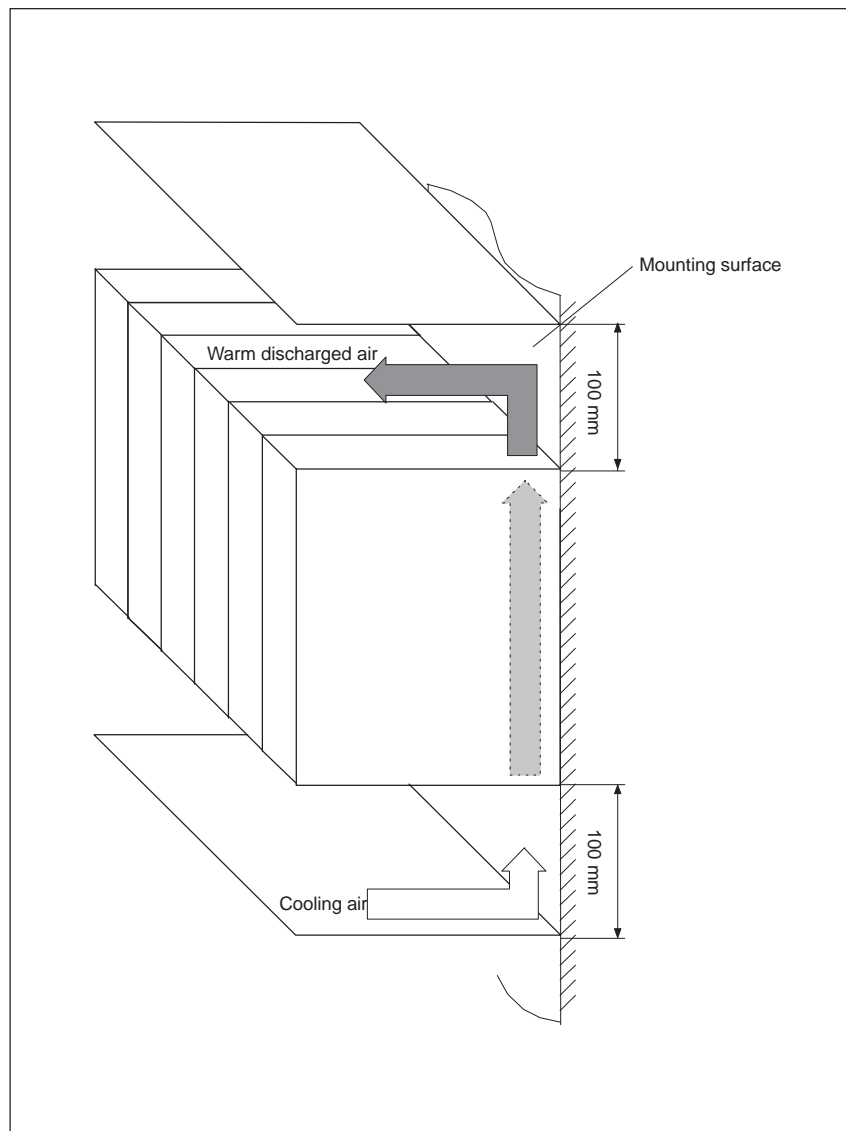

Fig. 9-5 Air flow in the electrical cabinet

**Notice**

For modules that generate a significant amount of heat, pulsed resistor module, 5 kW and 10 kW UI module, a heat deflecting plate (100 mm wide) should be used to protect the cable from excessive temperature. (For the pulsed resistor module, 50 mm wide, mounted so that they overlap.)

### Air intake when arranging power modules

Measures are shown in the following diagram if the following conditions/arrangements simultaneously exist in the cabinet:

- Number of power modules (50 mm wide)  $N > 10$
- Shield plate
- Channel cable

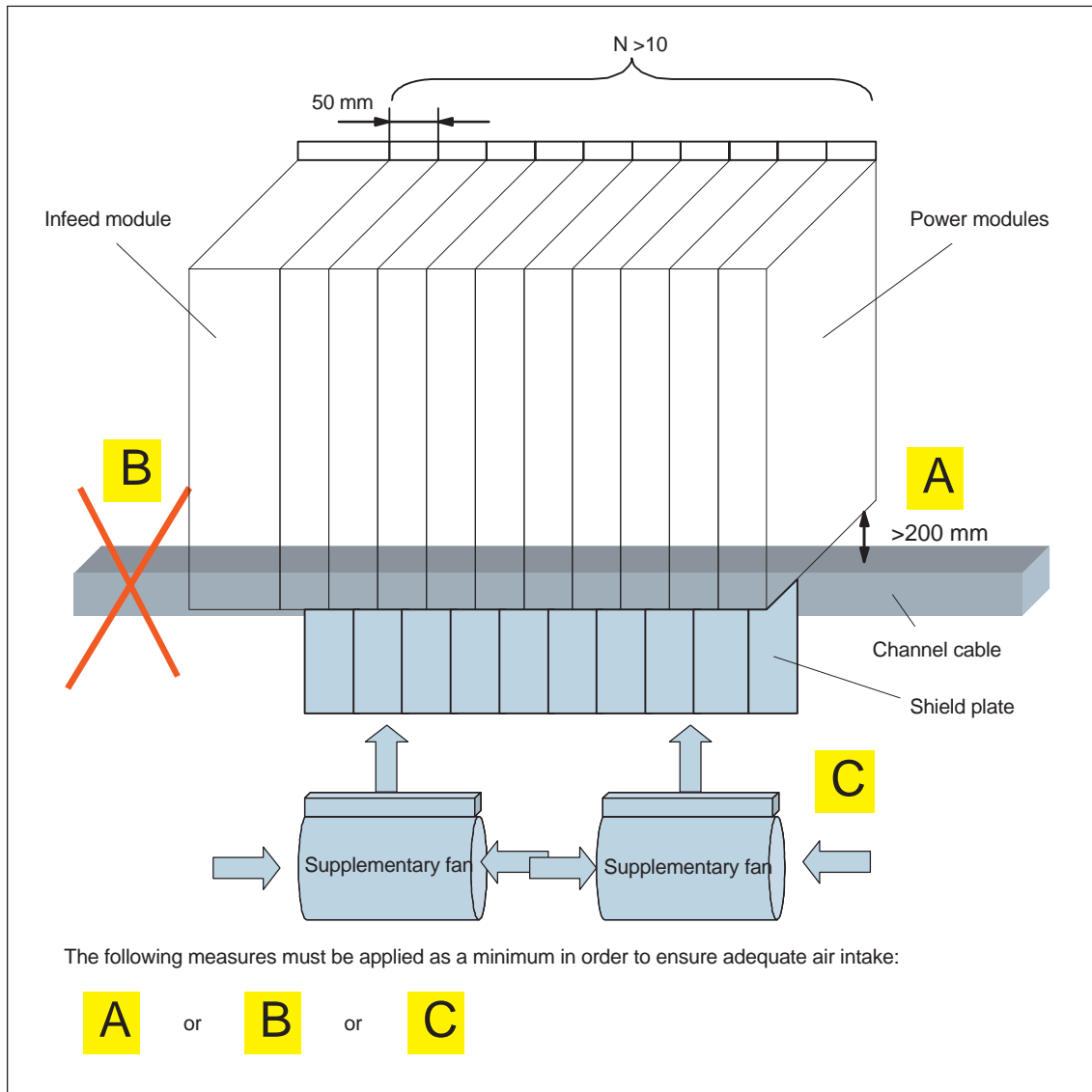

Fig. 9-6 Measures when building the cabinet

### Cable routing

Cables may not be routed over modules; the ventilation grilles may not be covered. The 50 mm wide devices are especially critical.



## 9.1 Installation and connecting-up regulations

## 9.1.3 Two-tier equipment configuration

**Arrangement**

The modules of the SIMODRIVE 611 drive converter system can also be arranged in two tiers one above the other or next to each other.

The distance between the rows of modules may not be less than 200 mm to ensure unrestricted cooling. In this case it must be ensured that the cooling air for the upper lineup does not exceed 40 °C – or with derating does not reach 55 °C. Otherwise, measures must be taken, for example an air baffle plate must be used or offset mounting, see Fig 9-8. As a result of the equipment bus cable, dependent on the design, the maximum clearance is specified

When arranging the cable ducts that may be required for the wiring it must be ensured that the required minimum clearance to the SIMODRIVE 611 converter system is not fallen below.

The modules with the higher power ratings – as well as the infeed module – must be located in the upper row of modules.

The maximum expansion phase of a drive group is limited by the power rating of the infeed module. Only one equipment bus extension is permissible: Either to the left, e.g. for a second tier; or to the right, e.g. to bypass a cubicle panel.

**Connecting cable**

For the SIMODRIVE 611 drive converter system, for a two-tier equipment configuration, a connecting cable is required for the equipment and drive bus.

In the two-tier equipment configuration, the DC link is connected using parallel cables (max. length, 5 m; in conjunction with SIMODRIVE POSMO SI/CD/CA, the guidelines correspond to the User Manual SIMODRIVE POSMO SI/CD/CA).

The required cable cross-section of the connecting cable for the downstream modules can be obtained from the dimension drawing in Fig. 12-60. The three cables should be tied together. These cables are not included with the equipment.

The dimensions, specified in the diagram 9-7 apply for the DC link connection of components that are separately located next to each other, e.g. extending over several electrical cabinets.

**Adapter terminals to connect the DC link**

Adapter terminals are available to connect the DC link.

The DC link voltage can be connected further using these adapter terminals, e.g. to connect the DC link for two-tier configurations.

The following adapter terminals are available (refer to Fig. 9-7):

- Package with two double terminals 50 mm<sup>2</sup> for a module width 50...200 mm (to 100 A also for a module width of 300 mm) (Order No.: 6SN1161-1AA01-0BA0)
- Package with two double terminals 95 mm<sup>2</sup> for a module width of 300 mm (Order No.: 6SN1161-1AA01-0AA0)

**Danger**

Notice! Order No.: 6SN1161-1AA01-0AA0 Do not use for module widths 50 – 200 mm. Danger of death because the contact safety is endangered!

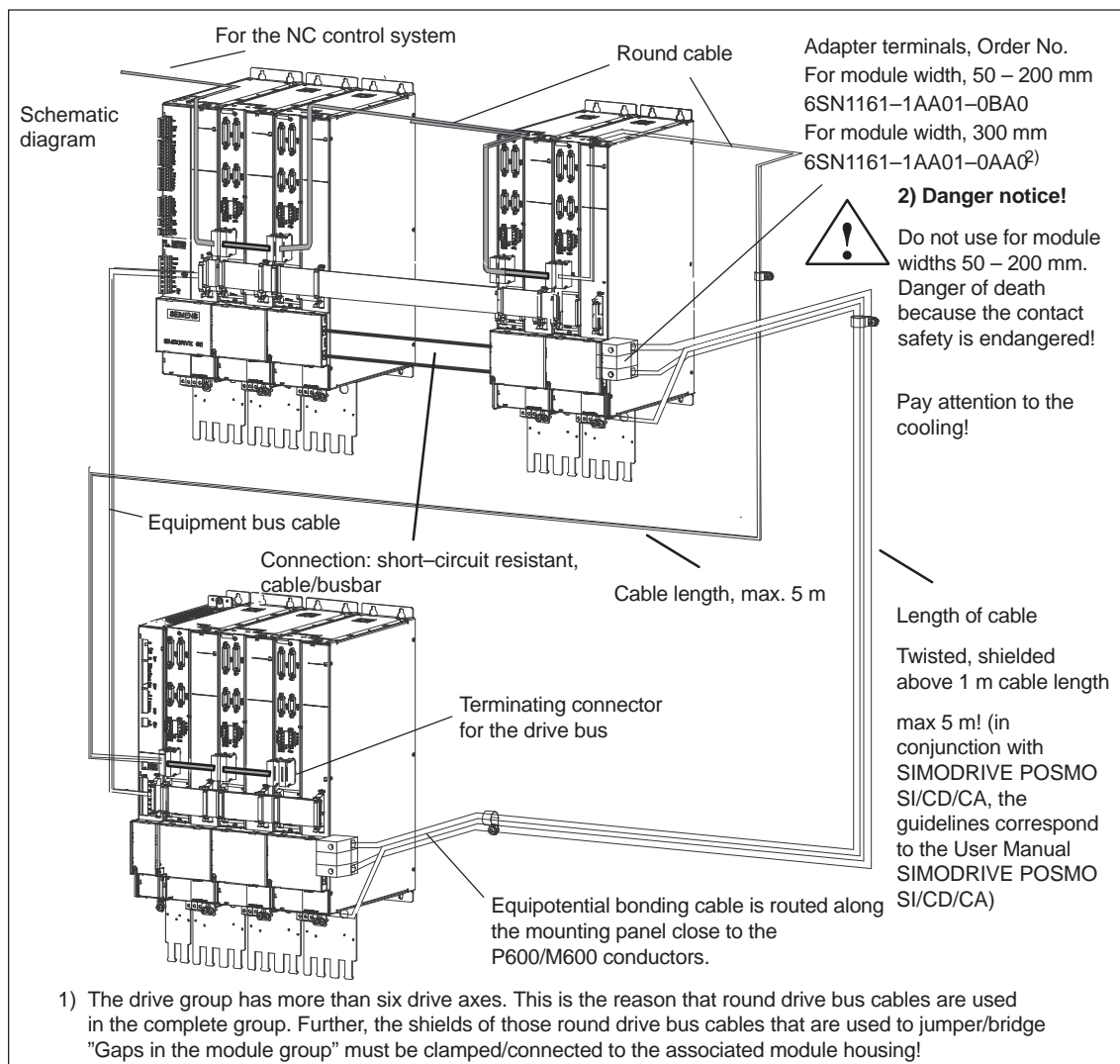

Fig. 9-7 Connection example, two-tier configuration

### Data on the system design

1. The continuous equipment bus cable of a drive group at one input module or monitoring module may be a maximum of 2.1 m long (from the supply point). For a two-tier configuration, two equipment bus branches, each with max. 2.1 m length from the branching point (supply point) can be used at the infeed.
2. 1500 mm equipment bus extension for a two-tier configuration with a branch at the supply/infeed point (Order No.: 6SN1161-1AA00-0AA1).
3. The drive bus length may not exceed 11 m.  
For more than six modules, control units, round cables must be used instead of ribbon cables.

### Note

Connection details for the DC link adapter set, refer to the dimension drawing in Fig. 12-59.

## 9.2 High-voltage test in the system

## Air supply

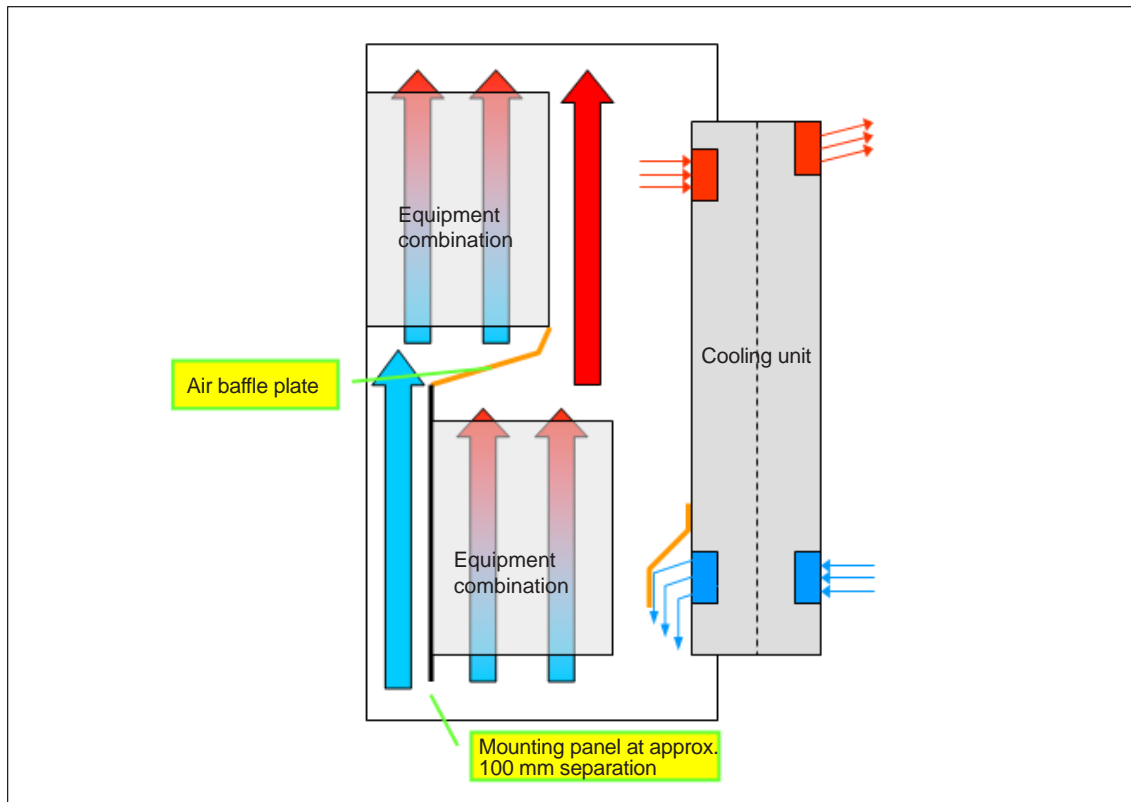

Fig. 9-8 Example of a two-tier cooling construction

## 9.2 High-voltage test in the system

It is permissible to perform a high-voltage test on SIMODRIVE 611 drive converters.

The components are designed/dimensioned in compliance with DIN EN 50178.

The following secondary conditions/limitations must be carefully observed when the system is subject to a high-voltage test:

1. Power-down the unit.
2. Withdraw the overvoltage module in order to prevent the voltage limiting responding.
3. Disconnect the line filter so that the test voltage does not dip.
4. Connect M600 to PE through resistor 100 k $\Omega$  (the grounding clip in the NE modules is open). In the factory, the units are subject to a high-voltage test at 2.25 kV<sub>DC</sub> phase-PE. The NE modules are shipped with the grounding clip open.
5. The maximum permissible voltage for a high-voltage system test is 1.8 kV<sub>DC</sub> phase-PE.

If these points are not carefully observed, then the modules can be damaged (preliminary damage).

## 9.3 Safety of machinery – safety-related parts of controls according to EN ISO 13849–1:2008

### 9.3.1 General information

With the introduction of EN 62061 and EN ISO 13849–1 as successor to the EN 945–1 standard, several things have changed regarding the assessment of suitable safety technology. Not only is the structure of a safety-related circuit taken into consideration, as was previously the case according to EN 954–1, but beyond this, the performance of the safety technology is also assessed along with the reliability; and if necessary, the software and many other related issues.

### 9.3.2 Safety-related stop functions of electric drive systems according to DIN EN 61800–5–2

#### Safety function STO – Safe Torque Off

##### Function

The Safe Torque Off (STO) function is a safety function to avoid unexpected starting. This function prevents the unexpected starting of a motor, connected to the drive control unit, from standstill. When the Safe Torque Off function is activated, the motor shaft cannot generate a torque.

##### Activation

This safety function should only be activated after the drive has come to a standstill, otherwise it loses its braking capability.

The standstill of the drive as well as the activation of the Safe Torque Off function must be realized and secured using an external machine control. If the drive is at a standstill and the Safe Torque Off function is active, additional brakes may be required for dangers due to the fact that the drive shaft is subject to an external torque.

For SIMODRIVE 611, the Safe Torque Off function is a "Device to shut down and avoid unexpected starting" according to EN 60204–1 Section 5.4. This behavior corresponds to stop Category 0, according to EN 60204–1:2006.

There is no electrical isolation from the line supply with the Safe Torque Off function. As a consequence, this function does not represent a protective device against electric shock.

#### Safety function SS1 – safe stop (time controlled)

##### Function

Initiates that the motor decelerates, and after an application-specific delay, initiates the STO function.

This behavior corresponds to stop Category 1, according to EN 60204–1:2006.

### Implementation for the drive system SIMODRIVE 611 digital and universal

**Closed-loop control**

On the control modules, which are inserted into the power module, each control module is equipped with a safety relay to implement the STO function. For double-axis modules, the safety relay acts on both axes.

**Line infeed**

Everyline infeed includes an integrated main contactor, which can be used for the Safe Torque Off function (STO).

#### 9.3.3 Control modules safety-related circuit

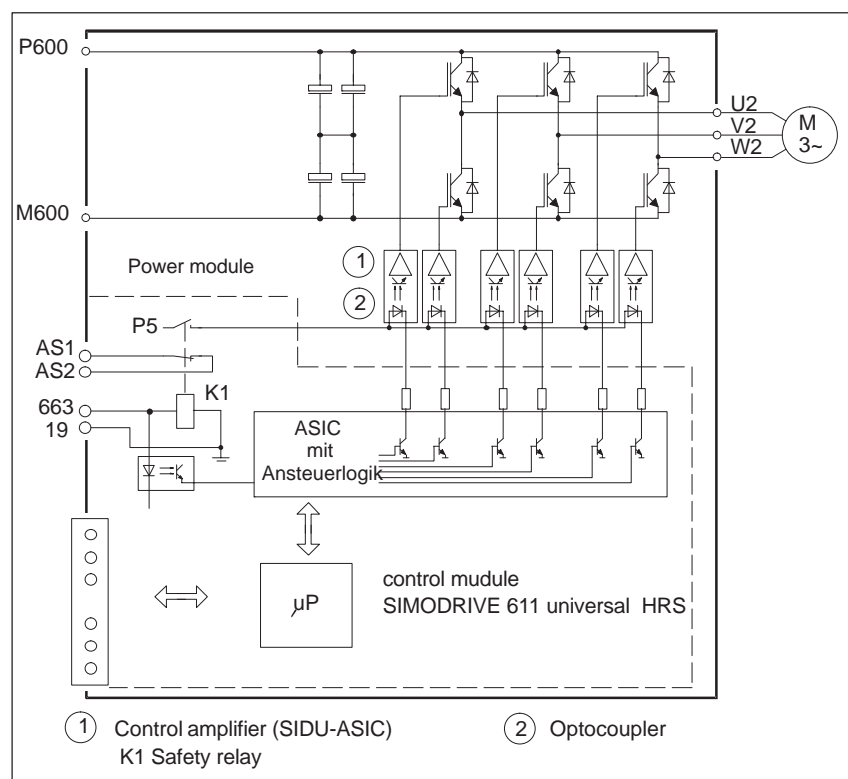

Fig. 9-9 SIMODRIVE 611 internal block diagram of the STO function

**Function**

The power unit controls the power feed to the individual motor windings.

The gating logic on the control module clocks the 6 power transistors using a specific pattern to generate a rotating field. An optocoupler is connected between the gating logic and each control amplifier of a power transistor to provide electrical isolation. Power supply P5 of the optocoupler is fed via the NO contact of safety relay K1. When the Safe Torque Off function is activated, the NO contact of the safety relay is opened and the NC contact (= feedback contact) is closed. The NO and NC contacts in the safety relay are positively driven. The state of the safety relay (NO contact) must be evaluated via the feedback signal contact AS1/AS2.

**Control**

When the Safe Torque Off function is active (in the normal state without fault) the contacts of the NO contact –K1 are open and the power supply to the optocouplers is interrupted.

In order that the control module of the SIMODRIVE 611 identifies the state Safe Torque Off, and processes it in the sequence control, the logical signal level of terminal 663 is signaled to the control module via an optocoupler. If the Safe Torque Off function is active, this input immediately generates a pulse inhibit via the control logic.

The feedback signal contact of the safety relay must be evaluated in every case and must be used to directly control a second shut off signal path.

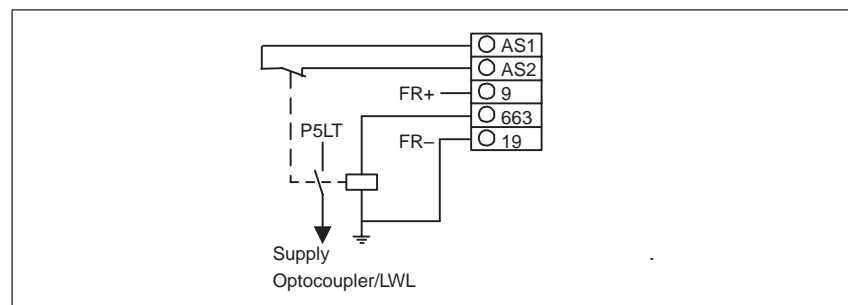

Fig. 9-10 SIMODRIVE closed-loop control STO control block diagram

Table 9-2 Value integrated safety relay

Terminal	Designation	Description	Type	Area
AS1	Contact 1	Relay feedback signal contact	Ö	30 V DC/ max. 2 A
AS2	Contact 2	Start inhibit		250 V AC/ max. 1 A
663	Control input "start inhibit"	Nominal resistance of the excitation coil at 20 °C ≥ 500 Ω	E	21 ... 30 V DC, maximum switching frequency: 6/min operating cycles: min. 20000 mechanical lifetime: 10 million operating cycles
9	Enable voltage FR+ (internal)		V	+24 V
19	Reference FR- (external)		V	Ground
B <sub>10d</sub> value of the integrated safety relay: 20,000,000 operating cycles, service life: 20 years				

### 9.3.4 Safety-related circuit infeed modules

#### Function

Every line infeed has an integrated main contactor, which can be used for the Safe Torque Off function (STO).

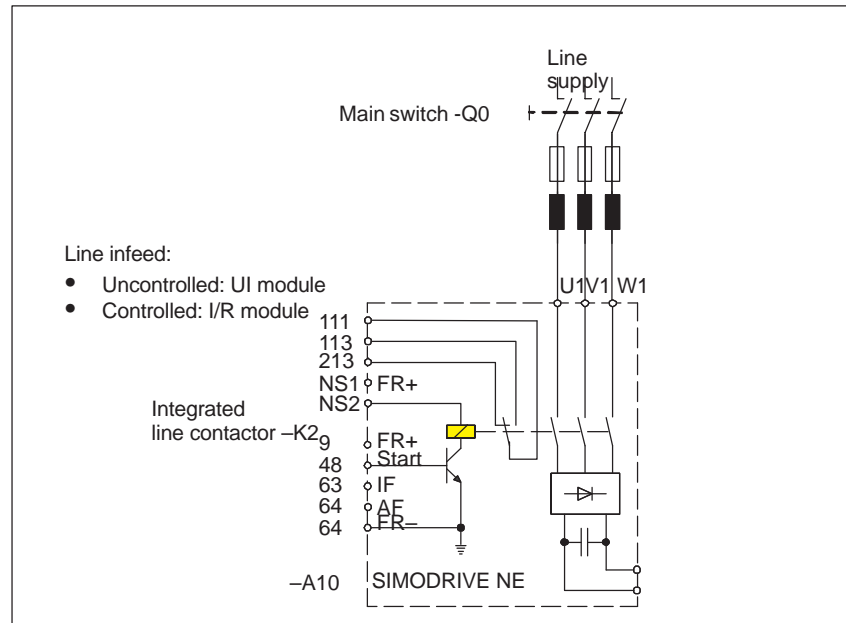

Fig. 9-11 Line infeed control line contactor, block diagram

The internal circuit of the line contactor via terminal 48 is shown symbolically. The control logic of the line and pre-charging contactors has a somewhat complex design, in order to guarantee a defined switch-on and switch-sequence.

Before interrupting the connection NS1–NS2, the line contactor must always be opened via terminal 48, or must be opened at the same time. The jumper between NS1 and NS2 when the unit is shipped must be removed.

$B_{10d}$  value of the integrated line contactor: 1,333,333 operating cycles

Service life: 20 years

### 9.3.5 Safety functions

**Description** With the SIMODRIVE 611 converter system, using the appropriate circuit, the following safety stop functions can be implemented:

Table 9-3 Safe stop functions

Function		Designation according to IEC 61800–5–2	Previous designation	Previous description
Safe standstill	Safe torque off	STO	SH	Safe standstill
			STOP A	Pulse inhibit/ start inhibit
Safe stop 1	Safe stop 1 (time controlled)	SS1	ext. STOP B	Stop Category 1 Fast stop

It should be noted that the safety functions only represent a very small part of the device functions.

A two-channel structure with suitable fault identification for the safety functions can be configured by using an appropriate circuit.

In order to implement the Safe Torque Off safety function in two channels, the line contactor integrated in the infeed modules as well as the safety relay integrated in the control modules should be used. The positively driven NC contacts of the line contactor and the safety relay should be evaluated as feedback signal.

The line fuses and feeder components should be selected and dimensioned according to the regulations as specified in Catalog NC60 as well as the Configuration Manual.

Main switch –Q0 is used as line disconnection device according to EN 60204–1:2006 and is not considered in the sense of functional safety.

There is no electrical isolation from the line supply with the Safe Torque Off function. As a consequence, this function does not represent a protective device against electric shock.

The safety functions integrated in the SINUMERIK 840D pl (SINUMERIK Safety Integrated) in conjunction with the SIMODRIVE 611D modules are not part of this documentation.

The CNC control modules SINUMERIK 840D have no influence on the evaluation of the safety functions.



### 9.3.6 Principle of STO in a safety function

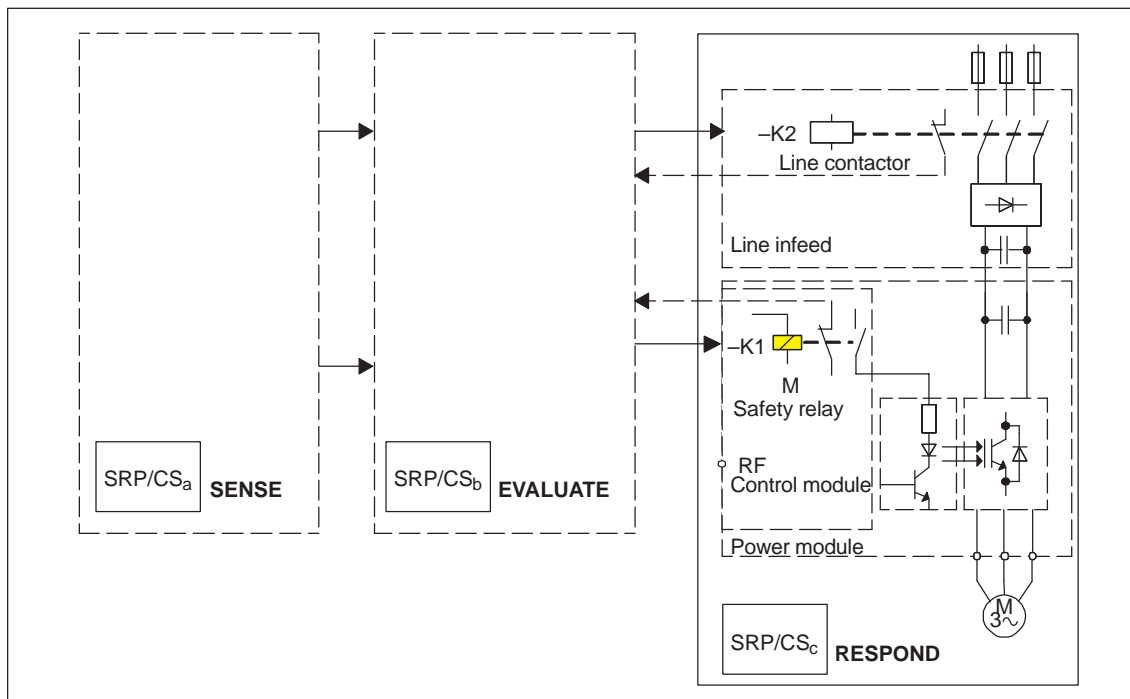

Fig. 9-12 Principle of STO, two-channel structure

A safety function essentially comprises two subsystems:

- SENSE
- EVALUATE
- RESPOND

Every safety function must be configured using suitable sensors, logic units and actuators.

#### SENSE, EVALUATE

The SENSE and EVALUATE subsystems are not considered in any more depth here. The selection and installation of the components must conform to the requirements of the safety function to be implemented.

#### RESPOND

The RESPOND subsystem in principle has a two channel structure. The first channel includes the safety relay –K1 of the drive. This operates according to the pulse shutdown principle with monitoring.

Line contactor –K2 forms the second channel, which is integrated in the line infeed. The line contactor is monitored using positively-driven NC contacts.

As an alternative to integrating the line contactor, it is also possible to use a motor contactor for each motor as the second safety-related channel. The calculation results of the following application examples can be analogously applied.

### 9.3.7 Principle of SS1 in a safety function

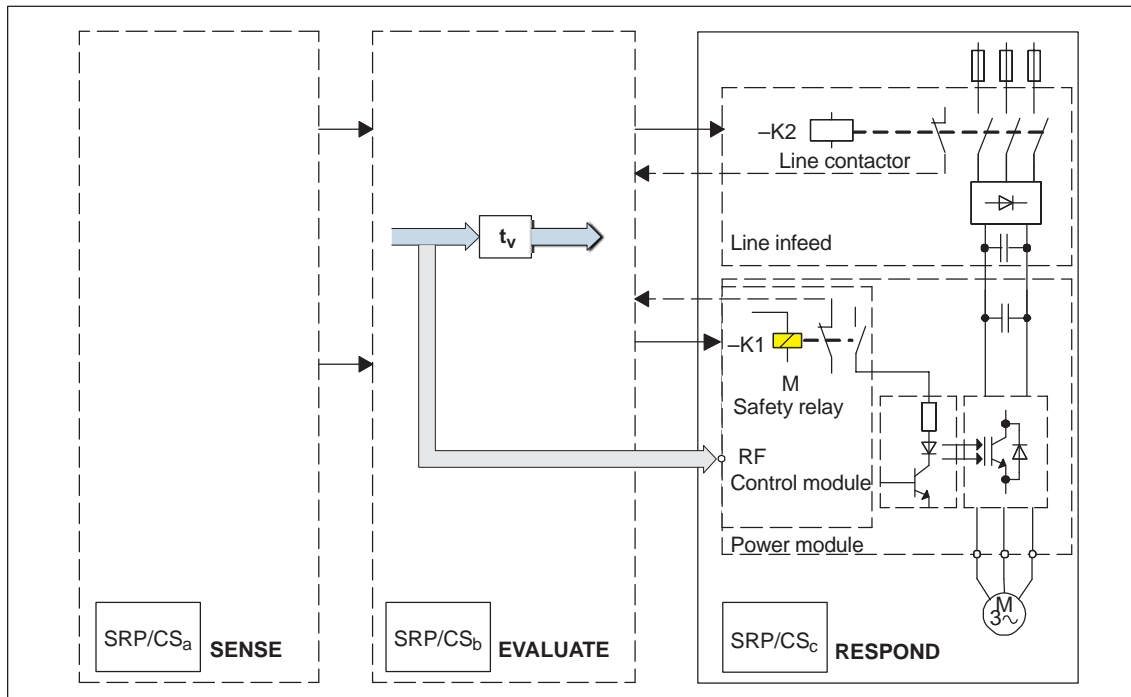

Fig. 9-13 Principle of SS1, two-channel structure

The SS1 safety function can also be achieved by using the STO safety function as basis and then adding a supplementary circuit. Also in this case, a basic two-channel architecture is configured.

#### SENSE

The SENSOR subsystem can have the same structure as described in Chapter 9.3.6.

Activating the safety function using the SENSE subsystem immediately initiates that the drive is stopped through a single channel. At the same time, a safe timer is started in EVALUATE.

The drives can be stopped, for example, by ramping-down the drives in a controlled fashion via the NC program, by inhibiting the drive enable terminal 64 or the axes-specific control enable, terminal 65.

The OFF delay of the timer should be set so that the drive has come to a standstill along the fast stopping ramp before this delay time has expired. After the timer has expired, the drive is safely switched into a no-torque condition according to Chapter 9.3.6.

#### EVALUATE

The EVALUATE subsystem must be expanded by a safety-related OFF-delay.

## 9.4 Application examples

### General

For all SIMODRIVE devices the basic principle of the safety-related circuit is the same. However, the different devices can have different terminal designations. The following circuit examples can be used, in an adapted form, for all SIMODRIVE infeeds and drives. The specifications to prove the Performance Level can be kept.

For reasons of transparency, in the following examples, only the safety-related terminals are connected. To move the drives, all of the necessary enable terminals must be supplied.

In the following examples, power contactors with mirror contacts as well as contactor relays with positively-driven contacts are used. For reasons of simplicity, the mirror contacts of the power contactors are designated as standard as positively-driven contacts.

Table 9-4 Parameter definition acc. to EN ISO 13849-1:2008

Definition	Description
$B_{10d}$	Lifetime of products where up to 10 % of the product range fails in a "dangerous" fashion (dangerous failure)
CCF	Common cause failure
DC	Diagnostic coverage level
$DC_{avg}$	Average diagnostic coverage level
$d_{op}$	Average operating time in days per annum
$MTTF_d$	Mean time to a dangerous failure
$n_{op}$	Average frequency of actuation per annum
$PFH_d$	Probability of a dangerous failure per hour for continuous use
PL	Performance Level, which specifies the capability of the safety-related parts of a control
SRP/CS	Part of a control, which responds to safety-related input signals and generates safety-related output signals

### 9.4.1 EMERGENCY STOP at a converter → SS1

#### Requirement

The supplementary safety function EMERGENCY STOP results in the drive being safely stopped in a controlled fashion. After the stopping time has expired, the drive is safely switched into a no-torque condition.

#### Assumption

The EMERGENCY STOP pushbutton is actuated 1x per month.

. As a result of the risk assessment, the required Performance Level for the safety function is defined to be  $PLr = d$ .

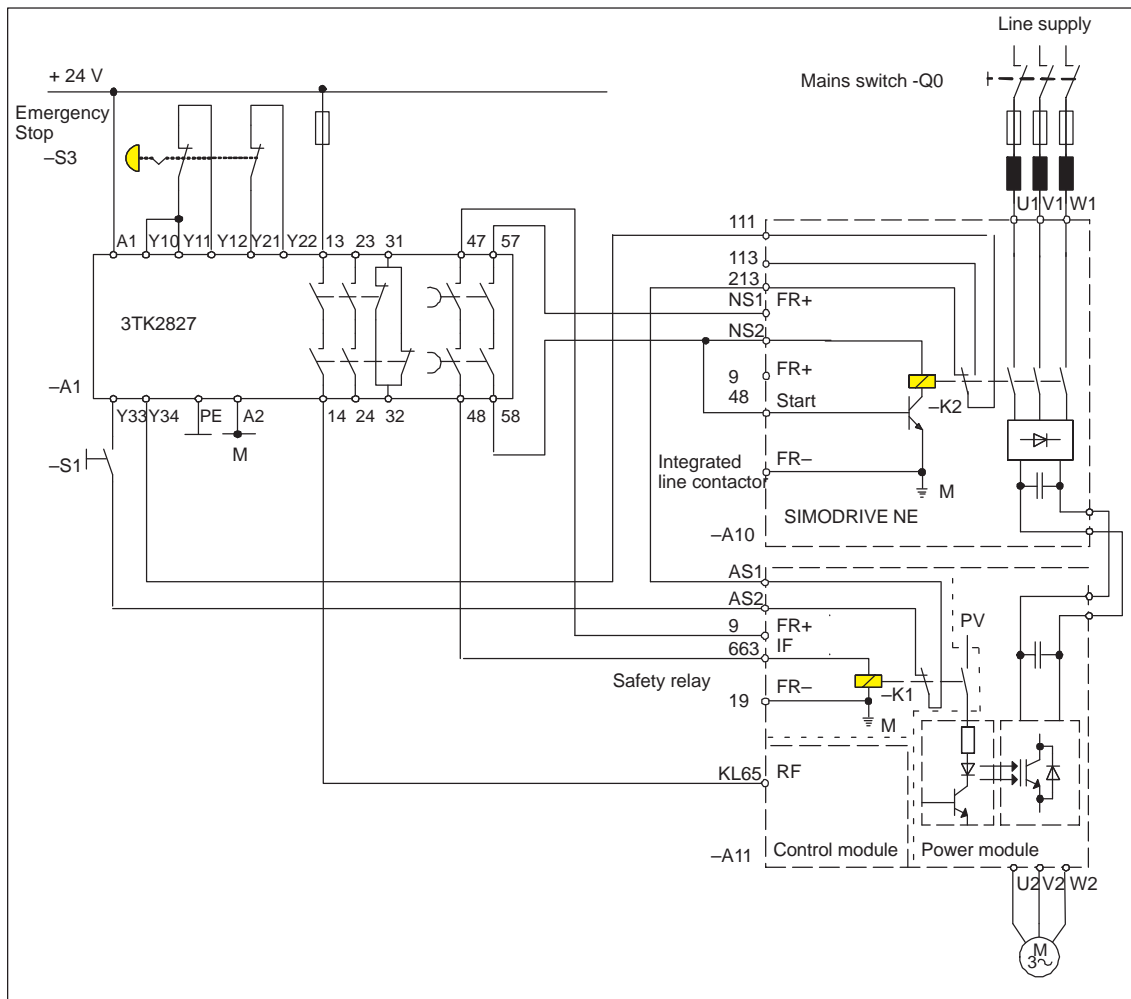

Fig. 9-14 EMERGENCY STOP at a SIMODRIVE 611 converter → SS1 at the drive

## 9.4 Application examples

**Prerequisite**

Is required to charge the DC link and move the drive:

- EMERGENCY STOP is released and the safety relay –A1 is reset via push-button –S1.
- Safety relay –K1 and line contactor –K2 are controlled by the contacts of safety relay –A1.

**Actuating  
EMERGENCY  
STOP**

- The instantaneous contacts of safety relay –A1 are opened. The axis-specific control enable RF (terminal 65) is switched to low. The drive is immediately braked to zero speed at the current limit.
- After the delay time of –A1 has expired, safety relay –K1 and line contactor –K2 are switched into a no-voltage state. The NO contacts open, and the motor is disconnected from the torque-generating power supply through two channels.
- This behavior corresponds to stop Category 1, according to EN 60204-1:2006.

**Limitations**

- If the pulses are canceled before the drive comes to a standstill, then it coasts down.
- Suspended/hanging axes must be secured using holding brakes or similar.

**Block diagram**

Fig. 9-15 Block diagram of the supplementary EMERGENCY STOP safety function

**SENSE subsystem**

The safety functions are initiated by the EMERGENCY STOP pushbutton, which can be released by turning, and which is connected through two channels. This has positively opening contacts.

Fault exclusion is assumed for the positively opening contacts as well as for the mechanical system of the EMERGENCY STOP pushbutton. An accumulation of faults between two consecutive actuations of the EMERGENCY STOP pushbutton can result in the safety function being lost. This behavior corresponds to Category 3.

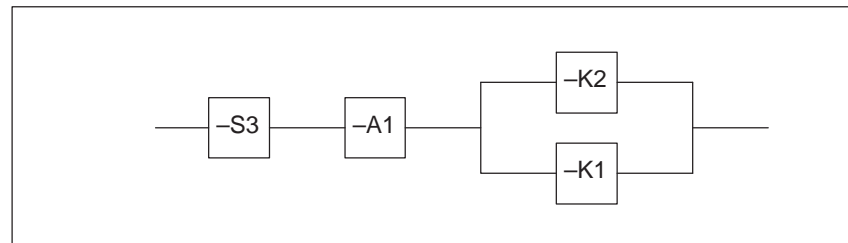
Table 9-5 Parameters for the SENSE subsystem

Parameter	Value	Comment
<b>EMERGENCY STOP pushbutton –S3</b>		
B10 value	100.000	Manufacturer's data
Percentage of dangerous failures	20 %	Manufacturer's data
B <sub>10d</sub> value	500.000	$B_{10d} = \frac{B10}{\text{percentage of dangerous failures}}$
n <sub>op</sub>	12 per year	assumed actuations per year
MTTF <sub>d</sub>	416.666 years → high	$MTTF_d = \frac{B_{10d}}{0,1 \times n_{op}}$
DC	99 %	Plausibility monitoring using –A1
<b>Result</b>		
PFH <sub>d</sub>	4,29 x 10 <sup>-8</sup> /h	EN ISO 13849–1:2008, Anhang K
<b>Performance Level</b>	<b>PLe</b>	with Category 3

## EVALUATE subsystem

In this example, the EVALUATE subsystem is implemented in the form of a SI-RIOUS 3TK3827 safety relay. The safety relay has instantaneous and delayed electromechanical enable circuits.

Table 9-6 Parameters for the EVALUATE subsystem

Parameter	Value	Comment
<b>Safety relay 3TK2827 –A1</b>		
PFH <sub>d</sub>	2,7 x 10 <sup>-9</sup> /h	Manufacturer's data
Service life	T1 = 20 years	Manufacturer's data
<b>Instantaneous enable circuit</b>		
Performance Level	PLe	with Category 4
<b>Delayed enable circuit</b>		
Performance Level	PLd	with Category 3
<b>Result</b>		
PFH <sub>d</sub>	2,7 x 10 <sup>-9</sup> /h	PFH <sub>d</sub> = PFH <sub>d</sub> (–A1)
<b>Performance Level</b>	<b>PLd</b>	with Category 3

## RESPOND subsystem

The RESPOND subsystem has a two channel structure. The first channel is implemented using safety relay –K1. The line contactor in the line infeed forms the second channel. Both channels are simultaneously controlled from safety relay –A1. The positively opening NC contacts of the contactor and relay are tested as feedback signal contacts by –A1 at each start.

## 9.4 Application examples

An accumulation of faults between two consecutive actuations of the EMERGENCY STOP pushbutton is not detected:

- Basic as well as well-proven safety principles – such as the requirements regarding Category B – are maintained. Protective circuits are provided.
- When a component fails, the safety function is always maintained. The failure is detected.

This structure corresponds to Category 3, according to EN 13849–1:2008.

### Determining MTTF<sub>d</sub>

Table 9-7 Determining MTTF<sub>d</sub>

Parameter	Value	Comment
<b>Channel 1</b>		
<b>Safety relay –K1 on the control module</b>		
B <sub>10d</sub> value	20.000.000	Manufacturer's data
n <sub>op</sub>	12 pro Jahr	12 actuations per year as a result of EMERGENCY STOP
MTTF <sub>d</sub> (–K1)	16.666.666 years → capped to 100 years	$MTTF_d = \frac{B_{10d}}{0,1 \times n_{op}}$
<b>Channel 2</b>		
<b>Line contactor –K2 in the line infeed</b>		
B <sub>10d</sub> value	1.333.333	Manufacturer's data
n <sub>op</sub>	12 pro Jahr	12 actuations per year as a result of EMERGENCY STOP
MTTF <sub>d</sub> (–K2)	1.111.111 years → capped to 100 years	$MTTF_d = \frac{B_{10d}}{0,1 \times n_{op}}$
<b>Intermediate results, RESPOND (channels 1 and 2)</b>		
<b>MTTF<sub>d</sub> (REAGIEREN)</b>	100 Jahre → <b>hoch</b>	MTTF <sub>d</sub> values for both channels were capped at 100 years → it is not necessary to symmetrize both channels

## Determining DC

Table 9-8 Determining the diagnostic coverage level (DC)

Parameter	Value	Comment
DC (channel 1)	90 %	Testing –K1 in the feedback circuit of –A1
DC (channel 2)	90 %	Testing –K2 in the feedback circuit of –A1
<b>DC<sub>avg</sub></b>	90 % → <b>average</b>	DC <sub>avg</sub> = DC (channel 1) = DC (channel 2)

## Determining the Performance Level

- Structure of the SRP/CS corresponding to Category 3
- $MTTF_d$  is high
- DC<sub>avg</sub> is average
- sufficient measures against common cause failures

Acc. to EN ISO 13849–1:2008 Annex K, **PLe with PFHd =  $4.29 \times 10^{-8}$  / h** is attained.

## Measures against common cause failures CCF of the safety function

According to EN ISO 13849–1 Annex F, for SRP/CS from Category 2, a minimum of 65 points is required.

Table 9-9 Measures according to EN ISO 13849–1 to attain SRP/CS from Category 2 and higher

Measure	Points
Physical separation between the signal paths: <ul style="list-style-type: none"> <li>• Separate wiring in the control cabinet</li> <li>• Sufficient creepages and clearances on printed circuits</li> </ul>	15
Protection against overvoltage, overcurrent	15
Using well-proven components	5
Diversity regarding the technology is applied as a result of the internal structure of the elements to evaluate and respond.	20
The requirements regarding sensitivity to all of the relevant ambient conditions, such as temperature, shock, vibration, humidity (for example as defined in the applicable standards) have been taken into account.	10
The design engineers have been trained to identify the reasons and effects of failures as a result of common causes.	5
Total	70

In total, the adequate number of 65 points is reached.



## Checking the PFH value of the complete safety function

Table 9-10 PFH value of the complete safety function

Parameter	PFH value	PL	Comment
SENSE	$4,29 \times 10^{-8} / \text{h}$	e	EMERGENCY STOP pushbutton –S3
EVALUATE	$2,7 \times 10^{-9} / \text{h}$	e	Safety relay –A1
RESPOND	$4,29 \times 10^{-8} / \text{h}$	e	Switching elements –K1 and –K2
<b>Total</b>	<b><math>8,85 \times 10^{-8} / \text{h}</math></b>	<b>e</b>	<b><math>&lt;1 \times 10^{-6} / \text{h}</math></b>

As a consequence, the requirements regarding PLd with Category 3 for the supplementary EMERGENCY STOP safety function are fulfilled.

### 9.4.2 EMERGENCY STOP and protective door monitoring at a converter → SS1

#### Requirement

- a) Opening the protective door stops the drive in a controlled fashion. After the stopping time has expired, the drive is safely switched into a no-torque condition.
- b) The supplementary safety function Emergency Stop results in the drive being safely stopped in a controlled fashion. After the stopping time has expired, the drive is safely switched into a no-torque condition

As a result of the risk assessment, the required Performance Level for both safety functions is defined to be PLr = d.

When the protective door is open, in normal operation, the DC link voltage should be kept.

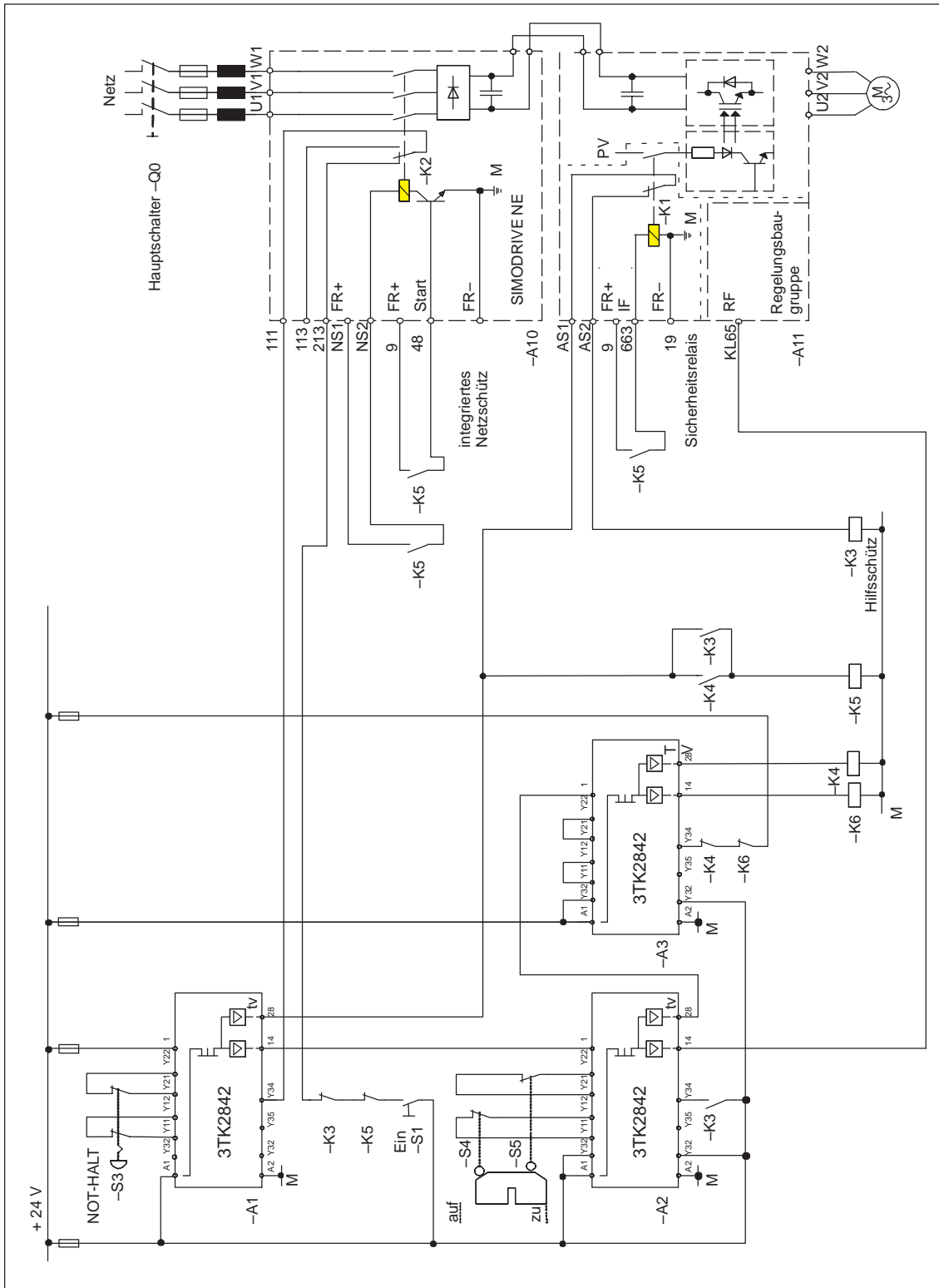

Fig. 9-16 EMERGENCY STOP and protective door monitoring at a SIMODRIVE 611 universal converter – SS1 at the drive

## 9.4 Application examples

**Preconditions to operate/move the drive**

- EMERGENCY STOP has been released and safety relay –A1 has been reset.
- Protective door is closed (position switch contacts –S4 and –S5 are closed).
- Safety relay –A2 is automatically started.
- \_ Safety relay –K1 is controlled via the NO contact of –K6, from the instantaneous output (14) of safety relay –A3.
- Line contactor –K2 is controlled via the contacts of –K5 using contactor relay –K4, from the delayed output (28) of safety relay –A3. The drive DC link is charged.
- The control enable on the control module has a high signal from safety relay –A2.

**The protective door is opened**

- EMERGENCY STOP has been released and safety relay –A1 has been reset.
- The cascading input of –A2 has a high signal.
- When the protective door is opened, the position switch contacts –S4 and –S5 are opened.
- The instantaneous output (14) from –A2 supplies a low signal at the drive controller enable. → The motor is stopped at the current limit.
- After the selected time at –A2 has expired, the delayed output (28) switches the cascading input (1) from –A3 to a low signal level.
- The instantaneous output (14) of –A3 switches–out (de–energizes) safety relay –K1 via –K6. (the drive pulses are canceled and in turn the energy feed to the motor is interrupted).
- The NC contact of –K1 controls contactor relay –K3. The NO contact of –K3 in parallel with –K4 closes and keeps line contactor –K2 connected to the power supply via –K5.
- After the time selected in –A3 expires, the delayed output (28) switches–out (de–energizes) contactor relay –K4. Line contactor –K2 remains controlled (energized) from –K5 via –K3. The DC link remains charged via terminal 4.

**Closing the protective door**

- –K1 is automatically controlled (energized) from –K6 via –A3.
- –K2 is again controlled (energized) from –K5 using –K4 via –A3.
- High signal at the controller enable input of the drive. → motor can be operated again.

**Actuating  
EMERGENCY  
STOP**

- The instantaneous output (14) of safety relay –A1 is de-energized, and therefore the cascading input (1) of –A2 is deactivated. –A2 behaves just the same as when opening the protective door.
- After the selected time at –A2 has expired, the delayed output (28) switches the cascading input (1) from –A3 to a low signal level.
- The instantaneous output (14) of –A3 switches-out (de-energizes) safety relay –K1 via –K6. (the drive pulses are canceled and in turn the energy feed to the motor is interrupted).
- The delayed output (28) of –A1 switches-out (de-energizes) line contactor –K2 after the selected time.

This behavior corresponds to stop Category 1, according to EN 60204–1:2006.

**Secondary  
conditions**

- The drive must be stopped within the delay time set at –A2. If the pulses are canceled before the drive comes to a standstill, then the drive will coast down.
- The time at –A3 should be set as short as possible, however so that –K3 pulls in before –K4 drops out in order to avoid that line contactor –K2 drops out.
- The delay time at –A1 should be set the same as the time of –A2.

## Safety function, protective door

If the protective door is opened, the drive should be safely stopped and after a safely monitored time, should be shut down.

### Assumption

In two-shift operation, the protective door is opened every 10 min. The plant is operational from Monday to Friday. The number of actuations is as follows:  $6 \cdot 1/h \cdot 16 \text{ h/d} \cdot 260\text{d} = 24960$  per year.

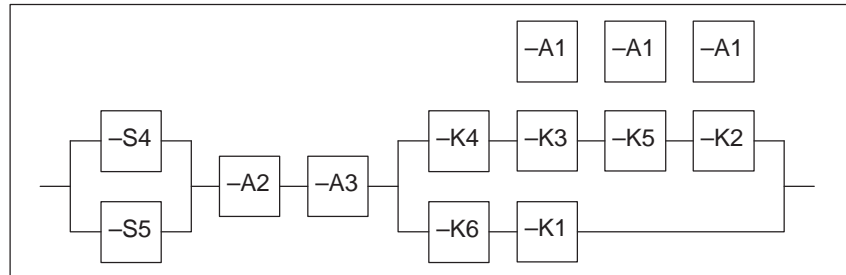

Fig. 9-17 Block diagram of the safety function, protective door

Safety relay  $-A1$  is used for the diagnostics of  $-K2$ ,  $-K3$  and  $-K5$ . It is not included in the calculation for the protective door safety function.

## SENSE subsystem

The protective door is monitored using two independent position switches  $-S4$  and  $-S5$ . Both position switches have a positively opening contact.

Table 9-11 Parameters for the SENSE subsystem

Parameter	Value	Comment
<b>Position switches <math>-S4</math> and <math>-S5</math></b>		
B10 value	10.000.000	Manufacturer's data
Percentage of dangerous failures	20 %	Manufacturer's data
$B_{10d}$ value	50.000.000	$B_{10d} = \frac{B_{10}}{\text{Percentage of dangerous failures}}$
$n_{op}$	24960 per years	assumed actuations per year
$MTTF_d$	20.032 years, capped to 100 years	$MTTF_d = \frac{B_{10d}}{0,1 \times n_{op}}$
DC	99 %	Plausibility monitoring using $-A2$
<b>Intermediate results, RESPOND (channels 1 and 2)</b>		
$MTTF_d$ (RESPOND)	100 years → <b>high</b>	$MTTF_d$ values for both channels were capped at 100 years → it is not necessary to symmetrize both channels
$DC_{avg}$	90 % → <b>average</b>	$DC_{avg} = DC$ (channel 1) = $DC$ (channel 2)
<b>Ergebnisse ERFASSEN</b>		
$PFH_d$	$2,47 \times 10^{-8} / h$	EN ISO 13849-1:2008, Annex K
Performance Level	<b>PLe</b>	with Category 4

## EVALUATE subsystem

In this example, the EVALUATE subsystem is implemented in the form of two SIRIUS 3TK2842 safety relays. The safety relays have instantaneous and delayed electromechanical enable circuits.

Device –A3 is used to provide a safety–related time delay when switching off and is controlled via the cascading input, terminal 1. Both devices –A2 and –A3, are used to evaluate the door switch and the feedback signals from the contactor relays.

Table 9-12 Parameters for the EVALUATE subsystem

Parameter	Value	Comment
<b>Safety relays 3TK2842 –A2 and –A3</b>		
PFH <sub>d</sub>	5,4 x 10 <sup>-11</sup> /h	Manufacturer's data
Service life	T1 = 20 Jahre	Manufacturer's data
Performance Level	PLe	with Category 4
<b>Result</b>		
PFH <sub>d</sub>	1,08 x 10 <sup>-10</sup> /h	PFH <sub>d</sub> = PFH <sub>d</sub> (–A2) + PFH <sub>d</sub> (–A3)
<b>Performance Level</b>	<b>PLd</b>	with Category 4

## RESPOND subsystem

The RESPOND subsystem has a two channel structure. The first channel comprises safety relay –K1 and contactor relay –K6. Line contactor –K2 and contactor relays –K3, –K4 and –K5 form the second channel.

In this example, the RESPOND subsystem has a two channel structure with different demand rates per channel. A dangerous fault in channel 1 means that channel 2 is immediately called with its monitoring options.

Components –K1, –K3, –K4 and –K6 are tested by –A2 or –A3 at each start.

Contactor –K2 and contactor relay –K5 are tested by –A1 at each start.

An accumulation of faults in channel 2 between two consecutive actuations of the EMERGENCY STOP pushbutton is not detected.

- Basic as well as well–proven safety principles – such as the requirements regarding Category B – are maintained. Protective circuits are provided. Protective circuits are provided.
- When a component fails, the safety function is always maintained. The failure is detected.

This structure corresponds to Category 3, according to EN ISO 13849–1:2008.

## 9.4 Application examples

Determining  
MTTF<sub>d</sub>Table 9-13 Determining MTTF<sub>d</sub>

Parameter	Value	Comment
<b>Channel 1</b>		
<b>Safety relay –K1</b>		
B <sub>10d</sub> value	20.000.000	Manufacturer's data
n <sub>op</sub>	24972 per years	24960 per year by the protective door + 12 per year by EMERGENCY STOP
MTTF <sub>d</sub> (–K1)	8008 years	$MTTF_d = \frac{B_{10d}}{0,1 \times n_{op}}$
<b>Contactor relay –K6</b>		
B <sub>10d</sub> value	1.333.333	Manufacturer's data
n <sub>op</sub>	24972 per year	24960 per year by the protective door + 12 per year by EMERGENCY STOP
MTTF <sub>d</sub> (–K6)	534 years	$MTTF_d = \frac{B_{10d}}{0,1 \times n_{op}}$
<b>Intermediate result, channel 1</b>		
MTTF <sub>d</sub> (channel 1)	501 years Capped to 100 years	$\frac{1}{MTTF_d(\text{Channel 1})} = \sum \frac{1}{MTTF_d(-K1, -K6)}$
<b>Channel 2</b>		
<b>Line contactor –K2</b>		
B <sub>10d</sub> value	1.333.333	Manufacturer's data
n <sub>op</sub>	12 per year	12 actuations per year as a result of EMERGENCY STOP
MTTF <sub>d</sub> (–K2)	1.111.111 years	$MTTF_d = \frac{B_{10d}}{0,1 \times n_{op}}$
<b>Auxiliary contactors –K3, –K4 and –K5</b>		
B <sub>10d</sub> value	1.333.333	Manufacturer's data
n <sub>op</sub>	24972 per year	24960 per year by the protective door + 12 per year by EMERGENCY STOP
MTTF <sub>d</sub> (contactor relay)	534 years	$MTTF_d = \frac{B_{10d}}{0,1 \times n_{op}}$
<b>Intermediate result, channel 2</b>		
<b>MTTF<sub>d</sub> (RESPOND)</b>	100 years → high	MTTF <sub>d</sub> values for both channels were capped at 100 years → it is not necessary to symmetrize both channels

## Determining DC

Table 9-14 Determining the diagnostic coverage level (DC)

Parameter	Value	Comment
DC (channel 1)	99 %	Testing –K1 via –K3 in the feedback circuit of –A2, as well as –K6 at –A3 each time the protective door is closed.
DC (channel 2)	90 %	Testing –K2 and –K3 in the feedback circuit of –A1 when EMERGENCY STOP is requested. Undetected accumulation of faults is possible between the requests. Testing –K4 in the feedback circuit of –A2 each time the protective door is closed.
<b>DC<sub>avg</sub></b>	94,50 % → <b>average</b>	$DC_{avg} = \frac{\frac{DC_1}{MTTF_d(\text{channel } 1)} + \frac{DC_2}{MTTF_d(\text{channel } 2)}}{\frac{1}{MTTF_d(\text{channel } 1)} + \frac{1}{MTTF_d(\text{channel } 2)}}$

## Determining the Performance Level

- Structure of the SRP/CS corresponding to Category 3
- $MTTF_d$  is high
- $DC_{avg}$  is average
- sufficient measures against common cause failures

Acc. to EN ISO 13849–1:2008 Annex K **PL<sub>e</sub> mit PFH<sub>d</sub> = 4,29 x 10<sup>-8</sup> / h** is attained.

## Measures against common cause failures CCF of the safety function

According to EN ISO 13849–1 Annex F, for SRP/CS from Category 2, a minimum of 65 points is required.

The considerations according to Chapter 9.4.1 Table 9-9.

This means that in total, the adequate number of 65 points is reached.

## Checking the PFH value of the complete safety function

Table 9-15 PFH value of the complete safety function

Parameter	PFH value	PL	Comment
SENSE	2,47 x 10 <sup>-8</sup> / h	e	Position switches –S4 and –S5
EVALUATE	2 x 5,4 x 10 <sup>-11</sup> / h	e	Safety relays –A2 and –A3
RESPOND	4,29 x 10 <sup>-8</sup> / h	e	Switching elements –K1, –K2, –K3, –K4, –K5 and –K6
<b>Total</b>	<b>8,59 x 10<sup>-8</sup> / h</b>	<b>e</b>	<b>&lt;1 x 10<sup>-6</sup> / h</b>

As a consequence, the requirements regarding PLd with Category 3 for the protective door safety function are fulfilled.



## Supplementary safety function, EMERGENCY STOP

If EMERGENCY STOP is actuated, then the drive should be safely stopped and shut down.

### Assumption

The EMERGENCY STOP pushbutton is actuated 1x per month.

The consideration for this safety function can be basically realized corresponding to the description in Chapter 9.4.2 "Protective door safety function".

However, the EMERGENCY STOP pushbutton as well as safety relay –A1 must also be taken into account for this safety function.

The position switches to monitor the protective door do not play a role when considering/analyzing EMERGENCY STOP.

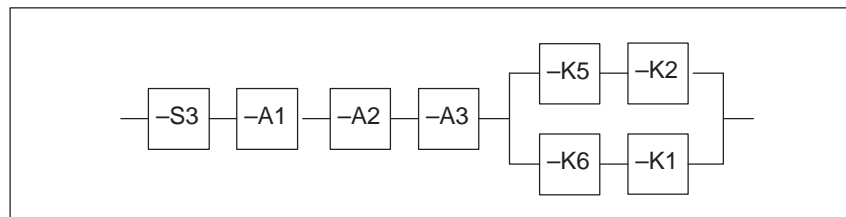

Fig. 9-18 Block diagram of the supplementary EMERGENCY STOP safety function

### SENSE subsystem

The safety functions are initiated by the EMERGENCY STOP pushbutton, which can be released by turning, and which is connected through two channels. This has positively opening contacts.

Fault exclusion is assumed for the positively opening contacts as well as for the mechanical system of the EMERGENCY STOP pushbutton. An accumulation of faults between two consecutive actuations of the EMERGENCY STOP pushbutton can result in the safety function being lost. This behavior corresponds to Category 3.

Table 9-16 Parameters for the SENSE subsystem

Parameter	Value	Comment
<b>EMERGENCY STOP pushbutton –S3</b>		
B10 value	100.000	Manufacturer's data
Percentage of dangerous failures	20 %	Manufacturer's data
B <sub>10d</sub> value	500.000	$B_{10d} = \frac{B10}{\text{Percentage of dangerous failures}}$
n <sub>op</sub>	12per years	assumed actuations per year
MTTF <sub>d</sub>	416.666 years → high	$MTTF_d = \frac{B_{10d}}{0,1 \times n_{op}}$
DC	99 %	Plausibility monitoring using –A1
<b>Result</b>		
PFH <sub>d</sub>	4,29 x 10 <sup>-8</sup> /h	EN ISO 13849–1:2008, AnnexK
<b>Performance Level</b>	<b>PLe</b>	with Category 3

## EVALUATE subsystem

The EVALUATE subsystem of the supplementary EMERGENCY STOP safety function is in this case realized using three SIRIUS 3TK3842 safety relays. The safety relays have instantaneous and delayed enable circuits.

Safety relay –A1 is used to evaluate the EMERGENCY STOP pushbutton. Devices –A2 and –A3 are used to provide a safety-related time delay when switching off and are controlled from –A1 via the cascading input, terminal 1.

Table 9-17 Parameters for the EVALUATE subsystem

Parameter	Value	Comment
<b>Safety relays 3TK2842 –A1, –A2 and –A3</b>		
PFH <sub>d</sub>	5,4 x 10 <sup>-11</sup> /h	Manufacturer's data
Service life	T1 = 20 years	Manufacturer's data
Performance Level	PLe	No differences between instantaneous and delayed enable circuits
<b>Result</b>		
PFH <sub>d</sub>	1,62 x 10 <sup>-10</sup> /h	PFH <sub>d</sub> = PFH <sub>d</sub> (–A1) + PFH <sub>d</sub> (–A2) + PFH <sub>d</sub> (–A3)
<b>Performance Level</b>	<b>PLe</b>	

## RESPOND subsystem

When actuating EMERGENCY STOP, the power supply of line contactor –K2 as well as contactor relay –K1 are shutdown (de-energized) via the delayed output (28) from –A1. When requesting EMERGENCY STOP, contactor relays –K3 and –K4 therefore have no influence on the correct function of –K1 and –K2.

Component –K1 is tested by –A2 via –K3 at each start. Contactor –K2 is tested by –A1 at each start.

An accumulation of faults in channel 2 between two consecutive actuations of the EMERGENCY STOP pushbutton is not detected.

- Basic as well as well-proven safety principles – such as the requirements regarding Category B – are maintained. Protective circuits are provided. Protective circuits are provided.
- When a component fails, the safety function is always maintained. The failure is detected.

This structure corresponds to Category 3, according to EN ISO 13849-1:2008.

## 9.4 Application examples

Determining  
MTTF<sub>d</sub>Table 9-18 Determining MTTF<sub>d</sub>

Parameter	Value	Comment
<b>Channel 1</b>		
<b>Safety relay –K1</b>		
B <sub>10d</sub> value	20.000.000	Manufacturer's data
n <sub>op</sub>	24972 per years	24960 per year by the protective door + 12 per year by EMERGENCY STOP
MTTF <sub>d</sub> (–K1)	8008 years	$MTTF_d = \frac{B_{10d}}{0,1 \times n_{op}}$
<b>Contactor relay –K6</b>		
B <sub>10d</sub> value	1.333.333	Manufacturer's data
n <sub>op</sub>	24972 per year	24960 per year by the protective door + 12 per year by EMERGENCY STOP
MTTF <sub>d</sub> (contactor relay)	534 years	$MTTF_d = \frac{B_{10d}}{0,1 \times n_{op}}$
<b>Intermediate result, channel 1</b>		
MTTF <sub>d</sub> (channel 1)	501 years Capped to 100 years	$\frac{1}{MTTF_d(\text{Channel 1})} = \sum \frac{1}{MTTF_d(-K1, -K6)}$
<b>Channel 2</b>		
<b>Line contactor –K2</b>		
B <sub>10d</sub> value	1.333.333	Manufacturer's data
n <sub>op</sub>	12 per year	12 actuations per year as a result of EMERGENCY STOP
MTTF <sub>d</sub> (–K2)	1.111.111 years	$MTTF_d = \frac{B_{10d}}{0,1 \times n_{op}}$
<b>Contactor relay –K5</b>		
B <sub>10d</sub> value	1.333.333	Manufacturer's data
n <sub>op</sub>	12 per year	12 actuations per year as a result of EMERGENCY STOP
MTTF <sub>d</sub> (contactor relay)	1.111.111 years	$MTTF_d = \frac{B_{10d}}{0,1 \times n_{op}}$
<b>Intermediate result, channel 2</b>		
MTTF <sub>d</sub> (Kanal 2)	555.555 years Capped to 100 years	$\frac{1}{MTTF_d(\text{Kanal 1})} = \sum \frac{1}{MTTF_d(-K2, -K5)}$
<b>Intermediate result, RESPOND (channel 1 and 2)</b>		
MTTF <sub>d</sub> (RESPOND)	100 years → high	MTTF <sub>d</sub> values for both channels were capped at 100 years → it is not necessary to symmetrize both channels

## Determining DC

Table 9-19 Determining the diagnostic coverage level (DC)

Parameter	Value	Comment
DC (channel 1)	99 %	Testing –K1 via –K3 in the feedback circuit of –A1
DC (channel 2)	99 %	Testing –K2 in the feedback circuit of –A1 when EMERGENCY STOP is requested
<b>DC<sub>avg</sub></b>	99 % → <b>high</b>	DC <sub>avg</sub> = DC (channel 1) = DC (channel 2)

## Determining the Performance Level

- Structure of the SRP/CS corresponding to Category 3
- $MTTF_d$  is high
- DC<sub>avg</sub> is high
- sufficient measures against common cause failures

Acc. to EN ISO 13849–1:2008 Annex K, **PL<sub>e</sub> mit PFH<sub>d</sub> = 4,29 x 10<sup>-8</sup> / h** is attained.

## Measures against common cause failures CCF of the safety function

According to EN ISO 13849–1 Annex F, for SRP/CS from Category 2, a minimum of 65 points is required.

The considerations according to Chapter 9.4.1 Table 9-9.

This means that in total, the adequate number of 65 points is reached.

## Checking the PFH value of the complete safety function

Table 9-20 PFH value of the complete safety function

Parameter	PFH value	PL	Comment
SENSE	4,29 x 10 <sup>-8</sup> / h	e	EMERGENCY STOP pushbutton –S3
EVALUATE	3 x 5,4 x 10 <sup>-11</sup> / h	e	Safety relays –A1, –A2 and –A3
RESPOND	4,29 x 10 <sup>-8</sup> / h	e	Switching elements –K1 and –K2, –K6 and –K5
<b>Total</b>	<b>8,6 x 10<sup>-8</sup> / h</b>	<b>e</b>	<b>&lt;1 x 10<sup>-6</sup> / h</b>

As a consequence, the requirements regarding PLd with Category 3 for the protective door safety function are fulfilled.

### 9.4.3 EMERGENCY STOP and protective door at several converters → SS1

#### Requirement

- a) Opening the protective door stops quickly stops the drives.  
After the stopping time has expired, the drives are safely switched into a no-torque condition.
- b) The supplementary safety function EMERGENCY STOP results in the drives being quickly stopped. After the stopping time has expired, the drives are safely switched into a no-torque condition

As a result of the risk assessment, the required Performance Level for both safety functions is defined to be PLr = d.

When the protective door is open, in normal operation, the DC link should be kept.

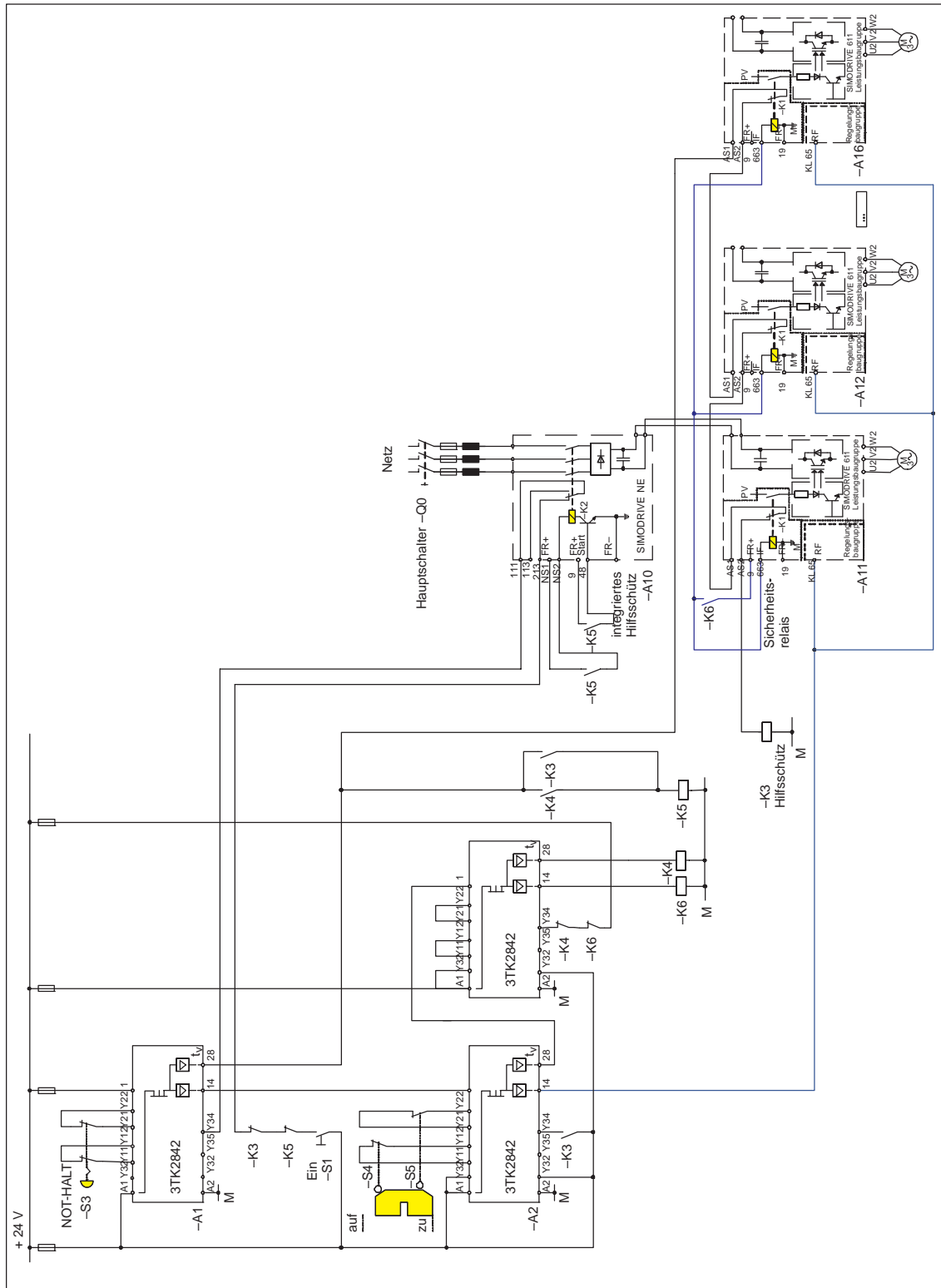

Fig. 9-19 EMERGENCY STOP and protective door monitoring at several SIMODRIVE 611 universal converters – SS1 at the drives

## Safety function, protective door

If the protective door is opened, the drive should be safely stopped and after a safely monitored time, should be shut down.

### Assumption

In three-shift operation, the protective door is opened every minute. The plant is operational from Monday to Sunday. The number of actuations is as follows:  $60 \cdot 1/h \cdot 24 \text{ h/d} \cdot 365\text{d} = 525600$  per year.

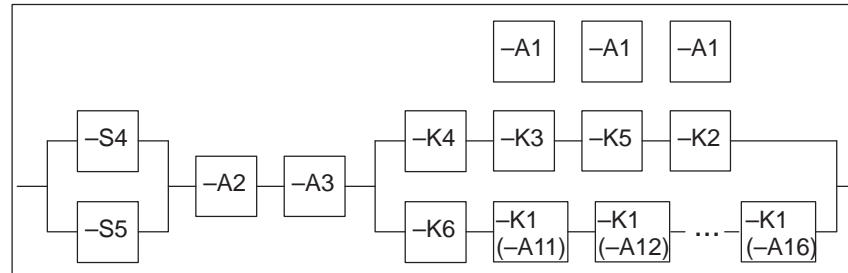

Fig. 9-20 Block diagram of the safety function, protective door for six axes

Safety relay  $-A1$  is used for the diagnostics of  $-K2$ ,  $-K3$  and  $-K5$ . It is not included in the calculation for the protective door safety function.

## SENSE subsystem

The evaluation of the SENSOR subsystem is explained in Chapter 9.4.2 "EMERGENCY STOP and protective door monitoring at a converter → SS1"

The higher number of switching cycles has no influence on the evaluation of this subsystem.

The results are taken over and used.

## EVALUATE subsystem

The evaluation of the EVALUATE subsystem is explained in Chapter 9.4.2 "EMERGENCY STOP and protective door monitoring at a converter → SS1".

The results are taken over and used.

## RESPOND subsystem

The RESPONSE subsystem is essentially structured as described in Chapter 9.4.2 "EMERGENCY STOP and protective door monitoring at a converter → SS1". Only the additional safety relays in channel 1 must still be taken into consideration.

## Determining MTTF<sub>d</sub>

Table 9-21 Determining MTTF<sub>d</sub>

Parameter	Value	Comment
<b>Channel 1</b>		
<b>Safety relay –K1</b>		
B <sub>10d</sub> value	20.000.000	Manufacturer's data
n <sub>op</sub>	525612 per year	525600 per year by the protective door + 12 per year by EMERGENCY STOP
MTTF <sub>d</sub> (–K1)	951 Jahre	$\text{MTTF}_d = \frac{B_{10d}}{0,1 \times n_{op}}$
<b>Contactor relay –K6</b>		
B <sub>10d</sub> value	1.333.333	Manufacturer's data
n <sub>op</sub>	525612 per year	525600 per year by the protective door + 12 per year by EMERGENCY STOP
MTTF <sub>d</sub> (contactor relay)	25,3 years	$\text{MTTF}_d = \frac{B_{10d}}{0,1 \times n_{op}}$
<b>Zwischenergebnis Kanal 1</b>		
MTTF <sub>d</sub> (channel 1)	21,8 years	$\frac{1}{\text{MTTF}_d(\text{channel 1})} = \sum \frac{1}{\text{MTTF}_d(-K1[-A11...-A16], -K6)}$
<b>Channel 2</b>		
<b>Line contactor –K2 and contactor relay –K5</b>		
B <sub>10d</sub> value	1.333.333	Manufacturer's data
n <sub>op</sub>	12 per year	12 actuations per year as a result of EMERGENCY STOP
MTTF <sub>d</sub> (–K2)	1.111.111 years	$\text{MTTF}_d = \frac{B_{10d}}{0,1 \times n_{op}}$
<b>Contactor relays –K3, –K4</b>		
B <sub>10d</sub> value	1.333.333	Manufacturer's data
n <sub>op</sub>	525612 per year	525600 per year by the protective door + 12 per year by EMERGENCY STOP
MTTF <sub>d</sub> (contactor relay)	25,3 years	$\text{MTTF}_d = \frac{B_{10d}}{0,1 \times n_{op}}$
<b>Intermediate result, channel 2</b>		
MTTF <sub>d</sub> (channel 2)	12,6 years	$\frac{1}{\text{MTTF}_d(\text{Kanal 1})} = \sum \frac{1}{\text{MTTF}_d(-K2, -K3, -K4, -K5)}$
<b>Intermediate result, RESPOND (channel 1 and 2)</b>		
<b>MTTF<sub>d</sub> (RESPOND)</b>	17,6 years → <b>average</b>	Symmetrization of both channels is not necessary
	$\text{MTTF}_d = \frac{2}{3} \frac{\text{MTTF}_{d1}(\text{channel 1}) + \text{MTTF}_d(\text{channel 2})}{\frac{1}{\text{MTTF}_d(\text{channel 1})} + \frac{1}{\text{MTTF}_d(\text{channel 2})}}$	



## 9.4 Application examples

## Determining DC

Table 9-22 Determining the diagnostic coverage level (DC)

Parameter	Value	Comment
DC (channel 1)	99 %	Testing –K1 (–A11...–A16) via –K3 in the feedback circuit of –A2, as well as –K6 at –A3 each time the protective door is closed.
DC (channel 2)	90 %	Testing –K2 and –K3 in the feedback circuit of –A1 when EMERGENCY STOP is requested. Undetected fault accumulation is possible between the demands. Testing –K4 in the feedback circuit of –A2 each time the protective door is closed.
<b>DC<sub>avg</sub></b>	93,3 % → <b>average</b>	$DC_{avg} = \frac{\frac{DC_1}{MTTF_d(\text{channel 1})} + \frac{DC_2}{MTTF_d(\text{channel 2})}}{\frac{1}{MTTF_d(\text{channel 1})} + \frac{1}{MTTF_d(\text{channel 2})}}$

## Determining Performance Level

- Structure of the SRP/CS corresponding to Category 3
- $MTTF_d$  is average
- $DC_{avg}$  is average
- Sufficient measures against common cause failures

Acc. to EN ISO 13849–1:2008 Annex K **PLd with  $PFH_d = 5,5 \times 10^{-7} / h$**  is attained.

**Note**

Contactors relays –K3, –K4 and –K6 should be replaced in plenty of time.

Operating time  $T_{10d} = B_{10d} / n_{op} = 2,54$  years.

**Measures against common cause failures CCF of the safety function**

According to EN ISO 13849–1 Annex F, for SRP/CS from Category 2, a minimum of 65 points is required.

The considerations according to Chapter 9.4.1 Table 9-9 apply.

This means that in total, the adequate number of 65 points is reached.

## Checking the PFH value of the complete safety function

Table 9-23 PFH value of the complete safety function

Parameter	PFH value	PL	Comment
SENSE	$2,47 \times 10^{-8} / \text{h}$	e	Position switches –S4 and –S5
EVALUATE	$2 \times 5,4 \times 10^{-11} / \text{h}$	e	Safety relays –A2 and –A3
RESPOND	$5,5 \times 10^{-7} / \text{h}$	d	Switching elements –K1(–A11...–A16), –K2, –K3, –K4, –K5 and –K6
<b>Total</b>	<b><math>5,74 \times 10^{-7} / \text{h}</math></b>	<b>d</b>	<b><math>&lt;1 \times 10^{-6} / \text{h}</math></b>

As a consequence, the requirements regarding PLd with Category 3 for the protective door safety function are fulfilled.

## EMERGENCY STOP safety function

This safety function corresponds, regarding its implementation, the explanation and information given in Chapter 9.4.2 "Supplementary safety function EMERGENCY STOP for an axis". Only in the RESPOND area, in channel 1, the additional safety relay –K1 has been added. This must also be taken into account when calculating the RESPOND subsystem.

The SENSE and EVALUATE subsystems are not affected by this.

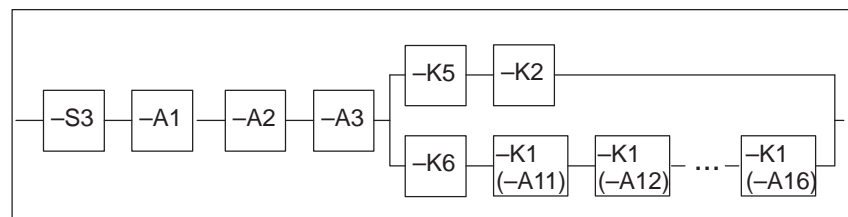

Fig. 9-21 Block diagram of the safety function, EMERGENCY STOP for six axes

## 9.5 Using programmable safety components

The circuit examples in Chapter 9.4 "Application examples" are, for reasons of transparency, configured using separate safety relays.

The logic component of the described safety functions can be implemented using programmable safety components, such as a fail-safe PLC systems, or the modular MSS safety system.

The safety relays can be monitored using software in the logic section. This means that the contactor relays can be eliminated.

9.5 Using programmable safety components

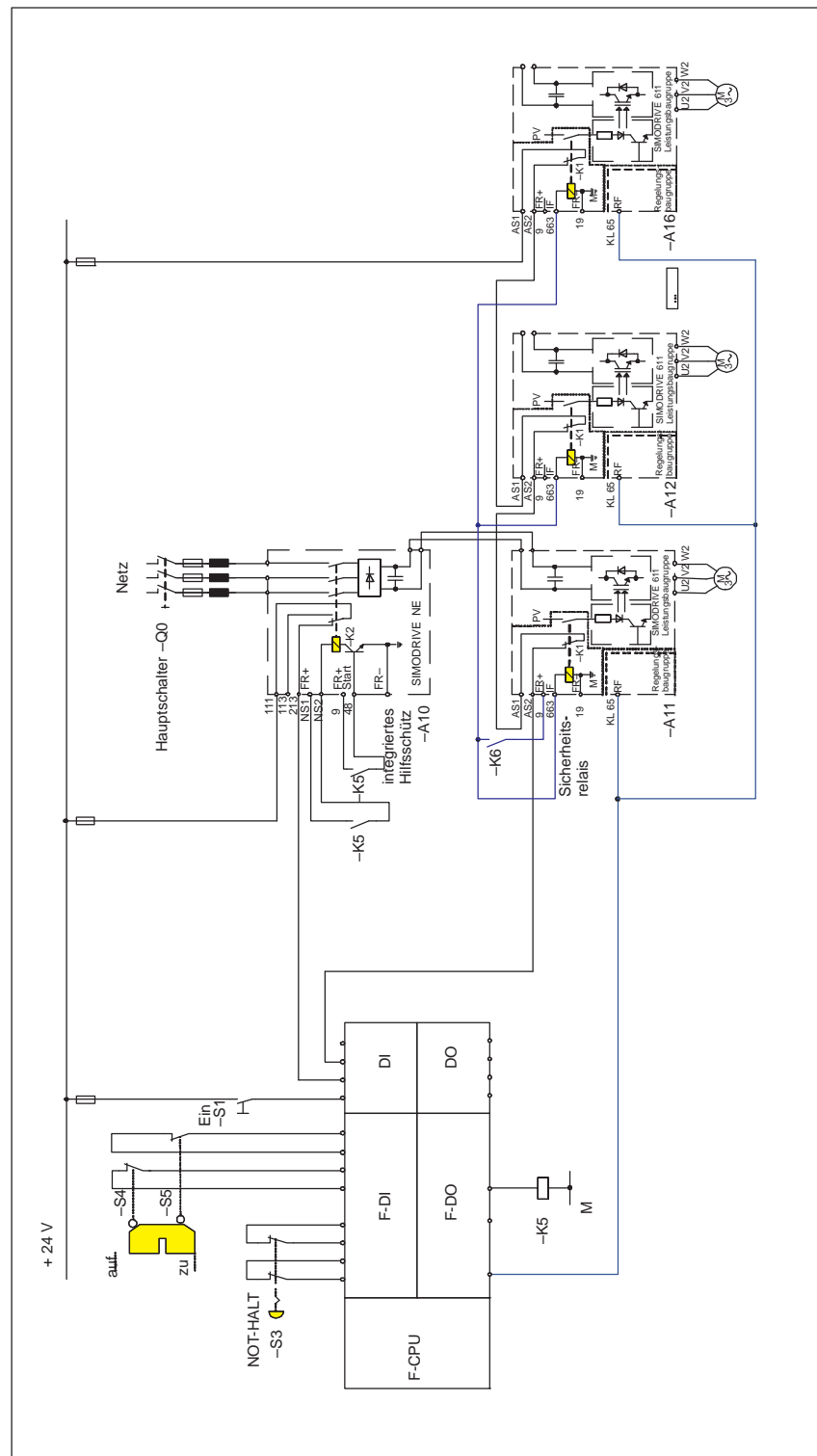

Fig. 9-22 Design with the safe programmable logic

The safety functions are calculated analogously to the previous examples using discrete safety relays.



---

**Note**

The following connection diagrams only show the terminal connections. Further, external components are not completely shown. Refer to Chapter 8.

The following comments should be observed in the connection diagrams:

1. The jumper may only be removed in conjunction with the start inhibit.
  2. Not available for unregulated infeed.
  3. Connect with terminal 19 of the NE module.
  4. Drive bus – round cable
  5. Drive bus – ribbon cable
  6. Drive bus – terminating connector
  7. For an external pulsed resistor, remove jumper 1R/2R.
-

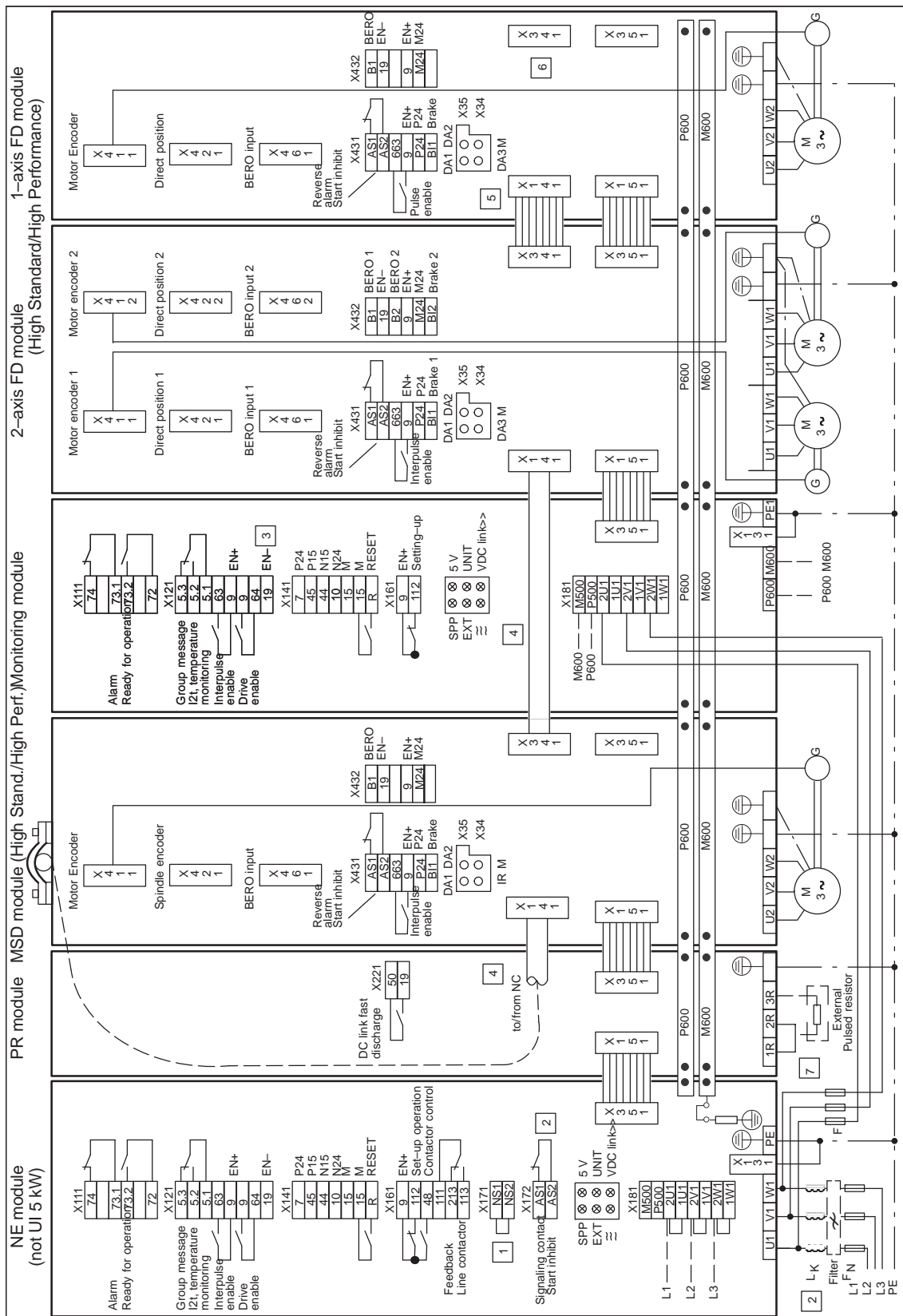

Fig. 10-1 Terminal overview SIMODRIVE 611 digital (High Standard and High Performance)

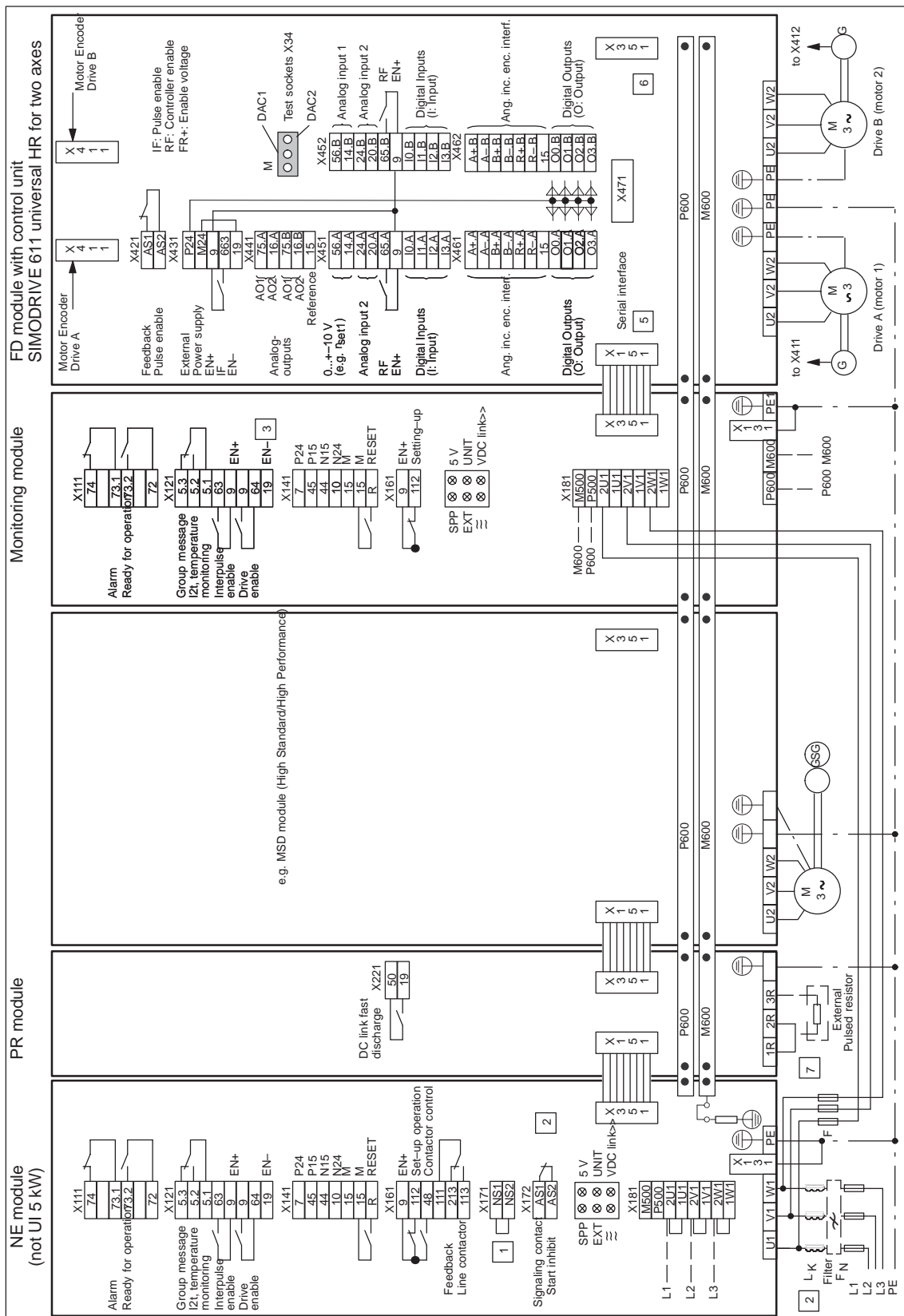

Fig. 10-2 Terminal overview, SIMODRIVE 611 universal HRS



## Spare Parts and Service

### 11.1 Fan

#### Notice

When replacing the fan, you must observe the ESD regulations.  
Spare parts must always be replaced by properly trained personnel!

#### Replacement options

Fan replacement with spare parts is possible for the following modules:

Table 11-1 Fan replacement options

Designation	Order No. (MLFB)	Module width [mm]	Fan spare parts (Order No.)
I/R module, 16 kW internal	6SN1145-1BA01-0BA□ <sup>1)</sup>	100	6SL3162-0AD00-0AA□
I/R module, 16 kW external	6SN1146-1BB01-0BA□ <sup>1)</sup>	100	6SL3162-0AD00-0AA□
I/R module, 36 kW internal	6SN1145-1BA02-0CA□ <sup>1)</sup>	200	6SL3162-0AF00-0AA□
I/R module, 36 kW external	6SN1146-1BB02-0CA□ <sup>1)</sup>	200	6SL3162-0AF00-0AA□
I/R module, 55 kW internal	6SN1145-1BA01-0DA□	300	- <sup>2)</sup>
I/R module, 55 kW external	6SN1146-1BB00-0DA□	300	6SL3162-0BA02-0AA□
I/R module, 55 kW internal/Schlauchentwärmung	6SN1145-1BB00-0DA□	300	6SL3162-0BA02-0AA□ <sup>3)</sup>
I/R module, 80 kW internal/Schlauchentwärmung	6SN1145-1BB00-0EA□	300	6SL3162-0BA02-0AA□ <sup>3)</sup>
I/R module 80, kW external	6SN1146-1BB00-0EA□	300	6SL3162-0BA02-0AA□
I/R module, 120 kW internal/Schlauchentwärmung	6SN1145-1BB00-0FA□	300	6SL3162-0BA02-0AA□ <sup>3)</sup>
I/R module, 120 kW external	6SN1146-1BB00-0FA□	300	6SL3162-0BA02-0AA□
PM module, 25 A internal	6SN1123-1AA00-0BA□ <sup>1)</sup>	50	6SL3162-0AB01-1AA□
PM module, 25 A external	6SN1124-1AA00-0BA□ <sup>1)</sup>	50	6SL3162-0AB01-1AA□
PM module, 50 A internal	6SN1123-1AA00-0CA□ <sup>1)</sup>	50	6SL3162-0AB00-0AA□
PM module, 50 A external	6SN1124-1AA00-0CA□ <sup>1)</sup>	50	6SL3162-0AB00-0AA□
PM module, 2x8 A internal	6SN1123-1AB00-0HA□ <sup>1)</sup>	50	6SL3162-0AB01-1AA□
PM module, 2x8 A external	6SN1124-1AB00-0HA□ <sup>1)</sup>	50	6SL3162-0AB01-1AA□
PM module, 2x15 A internal	6SN1123-1AB00-0AA□ <sup>1)</sup>	50	6SL3162-0AB01-1AA□
PM module, 2x15 A external	6SN1124-1AB00-0AA□ <sup>1)</sup>	50	6SL3162-0AB01-1AA□
PM module, 2x25 A internal	6SN1123-1AB00-0BA□ <sup>1)</sup>	50	6SL3162-0AB01-1AA□
PM module, 2x25 A external	6SN1124-1AB00-0BA□ <sup>1)</sup>	50	6SL3162-0AB01-1AA□



## 11.1 Fan

Table 11-1 Fan replacement options, continued

Designation	Order No. (MLFB)	Module width [mm]	Fan spare parts (Order No.)
PM module, 2x50 A internal	6SN1123-1AB00-0CA□ <sup>1)</sup>	100	6SL3162-0AD00-0AA□
PM module, 2x50 A external	6SN1124-1AB00-0CA□ <sup>1)</sup>	100	6SL3162-0AB00-0AA□ <sup>4)</sup>
PM module, 80 A internal	6SN1123-1AA00-0DA□ <sup>1)</sup>	100	6SL3162-0AD00-0AA□
PM module, 80 A external	6SN1124-1AA00-0DA□ <sup>1)</sup>	100	6SL3162-0AD00-0AA□
PM module, 108 A internal	6SN1123-1AA00-0LA□ <sup>1)</sup>	150	6SL3162-0AF00-0AA□
PM module, 108 A external	6SN1124-1AA00-0LA□ <sup>1)</sup>	150	6SL3162-0AF00-0AA□
PM module, 160 A internal	6SN1123-1AA00-0EA□	150	6SL3162-0AF00-0AA□
PM module, 160 A external	6SN1124-1AA00-0EA□	150	6SL3162-0AF00-0AA□
PM module, 200 A external	6SN1123-1AA01-0FA□	300	- <sup>2)</sup>
PM module, 200 A Extern	6SN1124-1AA01-0FA□	300	6SL3162-0BA02-0AA□
PM module, 200 A internal/pipe cooling	6SN1123-1AA02-0FA□	300	6SL3162-0BA02-0AA□ <sup>3)</sup>
PM module, 300 A internal/pipe cooling	6SN1123-1AA00-0JA□	300	6SL3162-0BA02-0AA□ <sup>3)</sup>
PM module, 300 A external	6SN1124-1AA00-0JA□	300	6SL3162-0BA02-0AA□
PM module, 400 A internal/pipe cooling	6SN1123-1AA00-0KA□	300	6SL3162-0BA02-0AA□ <sup>3)</sup>
PM module, 400 A external	6SN1124-1AA00-0KA□	300	6SL3162-0BA02-0AA□

- 1) Fan replacement possible from MLFBs with final number 2 and higher. MLFB final number < 2 means that the fan must be replaced by Siemens service!
- 2) Fan cannot be replaced
- 3) MLFB for standard mounting fans. Order designation for replacement fans, pipe cooling: GWE-000000587915. For additional spare/replacement parts of the pipe cooling, refer to the dimension drawings.
- 4) 2x are required

### Removing the fan

1. Switch off the line current supplies (I/R module) or DC link voltage (PM module). **Wait at least 30 minutes for the DC link energy to discharge!**
2. Verify that the fan is isolated from the supply (line supply input and DC link)!
3. Remove the components from the drive group.
4. Open the fan cover

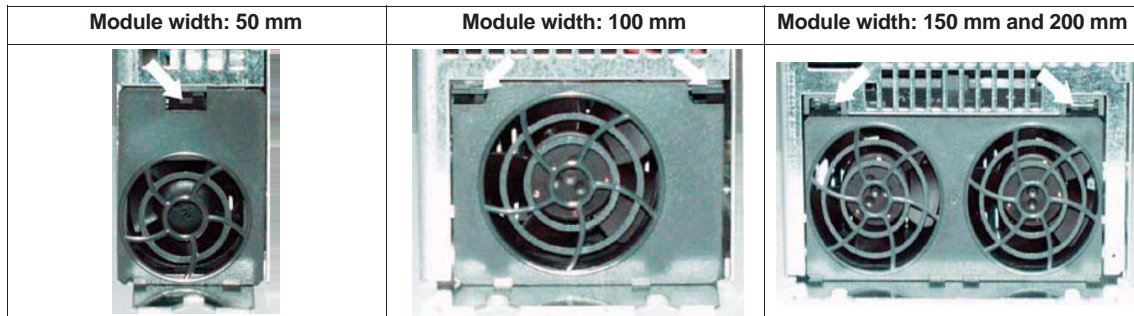

5. Taking out the fan
6. Loosen the cable connector

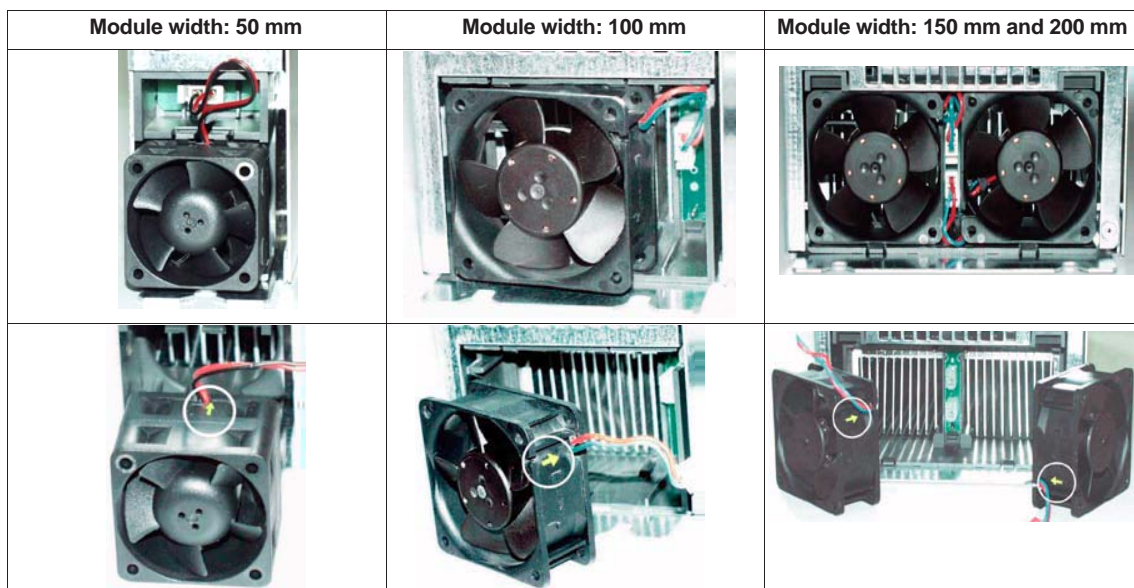

### Installing the fan

1. Before installing the fan, check the air flow direction (the arrow on the fan must point towards the cooling ribs).
2. Insert the cable connector until it fully engages.
3. Introduce the fan until it fully engages.  
**The connecting cables must not be interchanged!**
4. Close the fan cover.

## 11.3 DC link covers

## 11.2 Terminals

Table 11-2 Terminals for SIMODRIVE 611

Designation	Terminal	available in	MLFB
X421	2-pin	SIMODRIVE 611 universal HRS	6SY9907
X431	5-pin		6SY9908
X451, X452, X461, X462	10-pin		6SY9910
X461, X462 X453, X454	11-pin		6SY9913
X441	5-pin		6SY9911
X422, X432	8-pin	611 universal HRS option module terminals	6SY9912
Power connector, motor connection	3-pin		6SY9904
Power connector, pulsed resistor	3-pin		6SY9905
X161, X171, X172	2-pin	Module I/R, UI, monitoring module	6SY9433
X121	4-pin	UI module	6SY9432
X111, X161, X431, X432	6-pin	Module I/R, High Performance/High Standard module	6SY9896
X141	7-pin	I/R module	6SY9898
X121, X431, X432	8-pin	Module I/R, HLA/ANS module	6SY9897
X181 electronics power supply	8-pin	I/R module	6SY9900

## 11.3 DC link covers

Damaged DC link covers must be replaced without delay!

Table 11-3 DC link cover

Designation	Order Number
50 mm, DC link cover	GWE-462018701000
100 mm, DC link cover	GWE-462018701100
150 mm, DC link cover	GWE-462018701201
300 mm, DC link cover	GWE-462018701300

## 11.4 Inspection of the DC link capacitors of the PM modules



### Caution

After the devices have been non-operational in a no-voltage condition for more than two years, the DC link capacitors must be reformed. If this is not done, when the devices are switched on they can be damaged.

### Date of manufacture

The production date can be derived from the following assignment to the serial number (e.g. S T-S9□□□□□□ für 2004, September):

Table 11-4 Production year and Production month

Key	Production year	Key	Production month
A	1990, 2010	1	January
B	1991, 2011	2	February
C	1992, 2012	3	March
D	1993, 2013	4	April
E	1994, 2014	5	May
F	1995, 2015	6	June
H	1996, 2016	7	July
J	1997, 2017	8	August
K	1998, 2018	9	September
L	1999, 2019	O	October
M	2000, 2020	N	November
N	2001, 2021	D	December
P	2002, 2022		
R	2003, 2023		
S	2004, 2024		
T	2005, 2025		
U	2006, 2026		
V	2007, 2027		
W	2008, 2028		
X	2009, 2029		

The serial number is stamped on the type plate.

When forming, the DC link capacitors are subject to a defined voltage and a limited current. This means that the internal relationships required for the DC link capacitors to function are restored.

### Note

It is important that the storage period is calculated from the date of manufacture and not from the date that the equipment was shipped.

## 11.4 Inspection of the DC link capacitors of the PM modules

**Forming circuit**

The forming circuit is configured using incandescent lamps, or alternatively using PTC resistors.

Components required (recommendation):

- 1 fuse switch 3x 400 V / 10 A
- Cable, 1,5 mm<sup>2</sup>
- 3 PTC resistors 350 R / 35 W  
(Recommended: PTC-35W PTC800620-350 Ohm, company, Michael Koch GmbH; www.koch-mk.de)
- 3 incandescent lamps 230 V / 100 W
- Various small parts, such as lamp sockets, etc.

**Danger**

As a result of the DC link capacitors, after the device has been disconnected from the supply, voltages are present in the device for up to 5 min. It is only permissible to work on the device or the DC link terminals at the earliest after this wait time has expired!

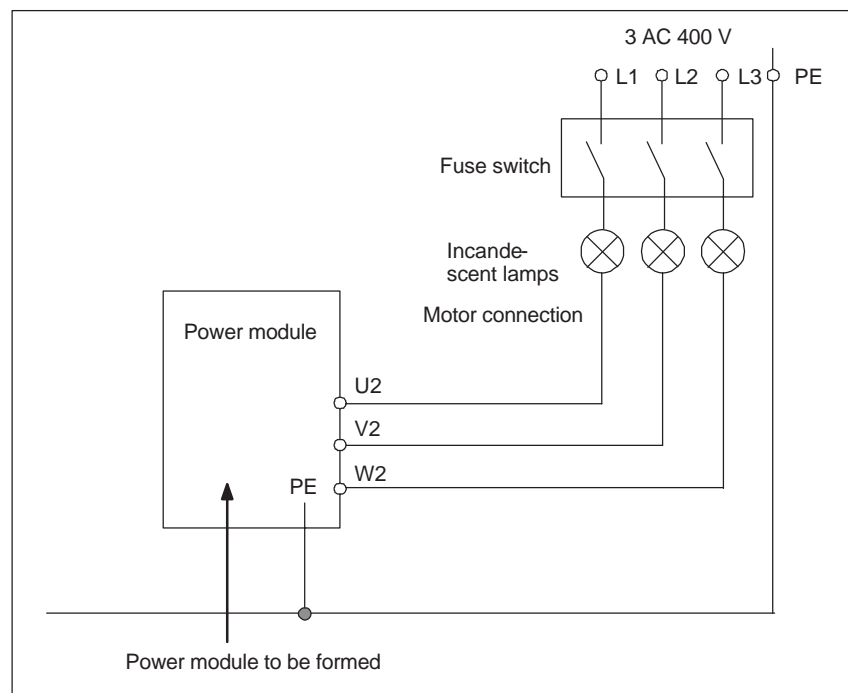

Fig. 11-1 Forming circuit comprising power modules with incandescent lamps

## 11.4 Inspection of the DC link capacitors of the PM modules

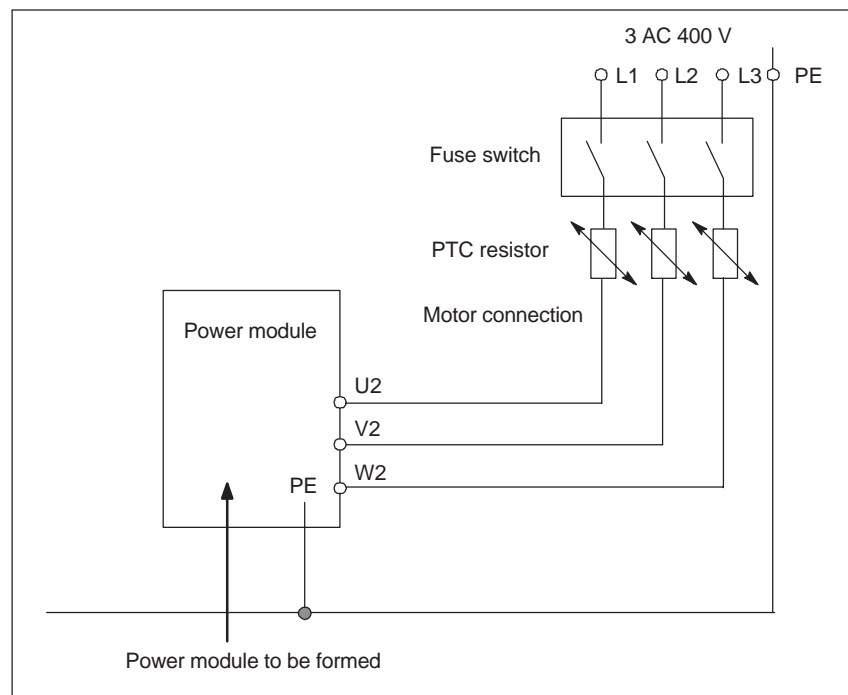

Fig. 11-2 Forming circuit comprising power modules with PTC resistors

### Procedure

- Before forming the DC link capacitors, it is imperative that the DC link bridge is removed.
- Ensure that the power module does not receive a switch-on command.
- Connect the forming circuit.
- Over the course of the forming time, the incandescent lamps must become darker/go out completely. If the incandescent lamps are continually lit, then there is a fault in the power module the wiring.
- When forming using PTC resistors, the modules must remain in the circuit for approximately 1 hour. If there is a fault in the power module, then the resistors will become very hot (surface temperature > 80 °C).

---

11.4 Inspection of the DC link capacitors of the PM modules

## Dimension Drawings

Fig. 12-1	Empty housing, Order No.: 6SN1162-1AA00-0AA0 .....	12-394
Fig. 12-2	Line filter "Wideband line filter" for I/R modules, 16 kW, 6SL3000-0BE21-6AAx .....	12-395
Fig. 12-3	Line filter "Wideband line filter" for I/R modules, 36 kW, 6SL3000-0BE23-6AAx .....	12-396
Fig. 12-4	Line filter "Wideband line filter" for I/R modules, 55 kW, 6SL3000-0BE25-5AAx .....	12-397
Fig. 12-5	Line filter "Wideband line filter" for I/R modules, 80 kW, 6SL3000-0BE28-0AAx .....	12-398
Fig. 12-6	Line filter "Wideband line filter" for I/R modules, 120 kW, 6SL3000-0BE31-2AAx .....	12-399
Fig. 12-7	Line filter "Basic line filter" for I/R modules 16 kW, 6SL3000-0BE21-6DAx .....	12-400
Fig. 12-8	Line filter "Basic line filter" for I/R modules 36 kW, 6SL3000-0BE23-6DAx .....	12-400
Fig. 12-9	Line filter "Basic line filter" for I/R modules 55 kW, 6SL3000-0BE25-5DAx .....	12-401
Fig. 12-10	Line filter for UI modules, 5 kW, 6SN1111-0AA01-1BA1 .....	12-402
Fig. 12-11	Line filter for UI modules, 10 kW, 6SN1111-0AA01-1AA1 .....	12-403
Fig. 12-12	Line filter for UI modules, 28 kW, 6SN1111-0AA01-1CA1 .....	12-404
Fig. 12-13	Adapter set, line filter for I/R module 16 kW, 6SL3060-1FE21-6AAx; dimension drawing .....	12-405
Fig. 12-14	Adapter set, line filter for I/R module 16 kW, 6SL3060-1FE21-6AAx; mounting .....	12-406
Fig. 12-15	Adapter set, line filter for I/R module 36 kW, 6SN1162-0GA00-0CAx; dimension drawing .....	12-407
Fig. 12-16	Adapter set, line filter for I/R module 36 kW, 6SN1162-0GA00-0CAx; mounting .....	12-408
Fig. 12-17	3-phase HFD line/commutating reactor 16 kW, 6SL3000-0DE21-6AAx .....	12-409
Fig. 12-18	3-phase HFD line/commutating reactor 36 kW, 6SL3000-0DE23-6AAx .....	12-410
Fig. 12-19	3-phase HFD line/commutating reactor 55 kW, 6SL3000-0DE25-5AAx .....	12-411
Fig. 12-20	3-phase HFD line/commutating reactor 80 kW, 6SL3000-0DE28-0AAx .....	12-412
Fig. 12-21	3-phase HFD line/commutating reactor 120 kW, 6SL3000-0DE31-2AAx .....	12-413
Fig. 12-22	Internal cooling, module width 50/100/150/200/300 mm .....	12-414
Fig. 12-23	Internal cooling, I/R modules 80 kW/120 kW and PW modules 300 A/400 A .....	12-415
Fig. 12-24	Built-on fan, 6SN1162-0BA02-0AA2; dimension drawing .....	12-416
Fig. 12-25	Built-on fan, 6SN1162-0BA02-0AA2; connection diagram .....	12-417
Fig. 12-26	Hose cooling for individual modules, 6SN1162-0BA03-0AA1 .....	12-418
Fig. 12-27	Hose cooling for 2-tier configuration, 6SN1162-0BA03-0CA1 .....	12-419
Fig. 12-28	EMC measures, Sheet 1 (example shield connection plate width 150 mm) .....	12-420



Fig. 12-29	EMC measures, Sheet 2 (shield connection plate, 6SN1162-0EA00-0AA0; -0BA0; -0CA0; -0JA0) .....	12-421
Fig. 12-30	EMC measures, Sheet 3 (shield connection plate, 6SN1162-0EA00-0DA0; -0KA0) .....	12-422
Fig. 12-31	EMC measures, Sheet 4 (shield connection plate, 6SN1162-0EB00-0AA0; -0BA0; -0CA0; -0JA0) .....	12-423
Fig. 12-32	EMC measures, Sheet 5 (shield connection plate, 6SN1162-0EB0-0DA0) .....	12-424
Fig. 12-33	External cooling, module width 50...200 mm .....	12-425
Fig. 12-34	External cooling, 50 mm 1–2 axes; PM module 6SN1124-1AA00-0xAx, 6SN1124-1AB00-0xA1 .....	12-426
Fig. 12-35	External cooling, 50 mm 1 axis; PM module 6SN1124-1AA00-0CA1 .....	12-427
Fig. 12-36	External cooling, 100 mm 1 axis; PM module 6SN1124-1AA00-0DA2 and I/R module 6SN1146-1BB01-0BA2 .....	12-428
Fig. 12-37	External cooling, 100 mm 2 axes; PM modul 6SN1124-1AB00-0CA2 .....	12-429
Fig. 12-38	External cooling, 150 mm 1 axis; PM module 6SN1124-1AA00-0EA2/-0LA3 .....	12-430
Fig. 12-39	External cooling, 200 mm; I/R module 6SN1146-1BB02-0CA2 ...	12-431
Fig. 12-40	External cooling, 300 mm PM module 6SN1124-1AA0x-0xA1 and I/R module 6SN1146-1BB00-0xA1; Sheet 1 .....	12-432
Fig. 12-41	Interneal/external cooling, 50 mm UI module (6SN1146-1AB00-0BAx); pulse resistor module (6SN1113-1AB01-0BAx); monitoring module (6SN1112-1AC01-0AAx) .....	12-433
Fig. 12-42	Internal/externa cooling, 100 mm UI module; 6SN1145-1AA01-0AA2 .....	12-434
Fig. 12-43	External cooling, 200 mm UI-Modul; 6SN1146-1AB00-0CA0 .....	12-435
Fig. 12-44	External cooling, installation cutout for installation frames .....	12-436
Fig. 12-45	External cooling, module 300 mm mounting plane, PM module 6SN1124-1AA0x-0xA1 and I/R module 6SN1146-1BB00-0xA1 ..	12-437
Fig. 12-46	External cooling, mounting frame for cabinet installation, 50 mm module width, 6SN1162-0BA04-0AA1 .....	12-438
Fig. 12-47	External cooling, mounting frame for cabinet installation, 50 mm module width, 6SN1162-0BA04-0FA1 .....	12-439
Fig. 12-48	External cooling, mounting frame for cabinet installation, 50 mm module width, 6SN1162-0BA04-0JA0 .....	12-440
Fig. 12-49	External cooling, mounting frame for cabinet installation, 100 mm module width, 6SN1162-0BA04-0BA1 .....	12-441
Fig. 12-50	External cooling, mounting frame for cabinet installation, 100 mm module width, 6SN1162-0BA04-0GA1 .....	12-442
Fig. 12-51	External cooling, mounting frame for cabinet installation module width 100 mm, 6SN1162-0BA04-0HA1 .....	12-443
Fig. 12-52	External cooling, mounting frame for cabinet installation, 150 mm module width, 6SN1162-0BA04-0CA1 .....	12-444
Fig. 12-53	External cooling, mounting frame for cabinet installation, 200 mm module width, 6SN1162-0BA04-0DA1 .....	12-445
Fig. 12-54	External cooling, mounting frame for cabinet installation, 300 mm module width, 6SN1162-0BA04-0EA0 .....	12-446
Fig. 12-55	Signal amplifier electronics SVE, 6SN1115-0AA12-0AA0 .....	12-447
Fig. 12-56	External pulsed resistor for 28kW for UI module, SN1113-1AA00-0DA0 .....	12-448
Fig. 12-57	External pulsed resistor Plus, 6SL3100-1BE22-5AA0 .....	12-449

Fig. 12-58 Damping resistor for 3-phase HFD line/commutating reactors, 6SL3100-1BE21-3AA0 .....	12-450
Fig. 12-59 Distributed capacitor modules, 6SN1112-1AB00-1xA0 .....	12-451
Fig. 12-60 DC link adapter set 16...50 mm <sup>2</sup> and 35...95 mm <sup>2</sup> 6SN1161-1AA01-0BA0/ -0AA0 .....	12-452
Fig. 12-61 Shield connection 6SN1162-0FA00-0AA1 (dimension drawing) ...	12-453
Fig. 12-62 Shield connection 6SN1162-0FA00-0AA2 (dimension drawing) ...	12-454
Fig. 12-63 Thermally conductive plate 6SN1162-0BA01-0AAx (dimension drawing) .....	12-455
Fig. 12-64 VPM 120, dimension drawing 6SN1113-1AA00-1JAx .....	12-456
Fig. 12-65 VPM 200/VPM 200 DYNAMIK, dimension drawing 6SN1113-1AA00-1xAx .....	12-457

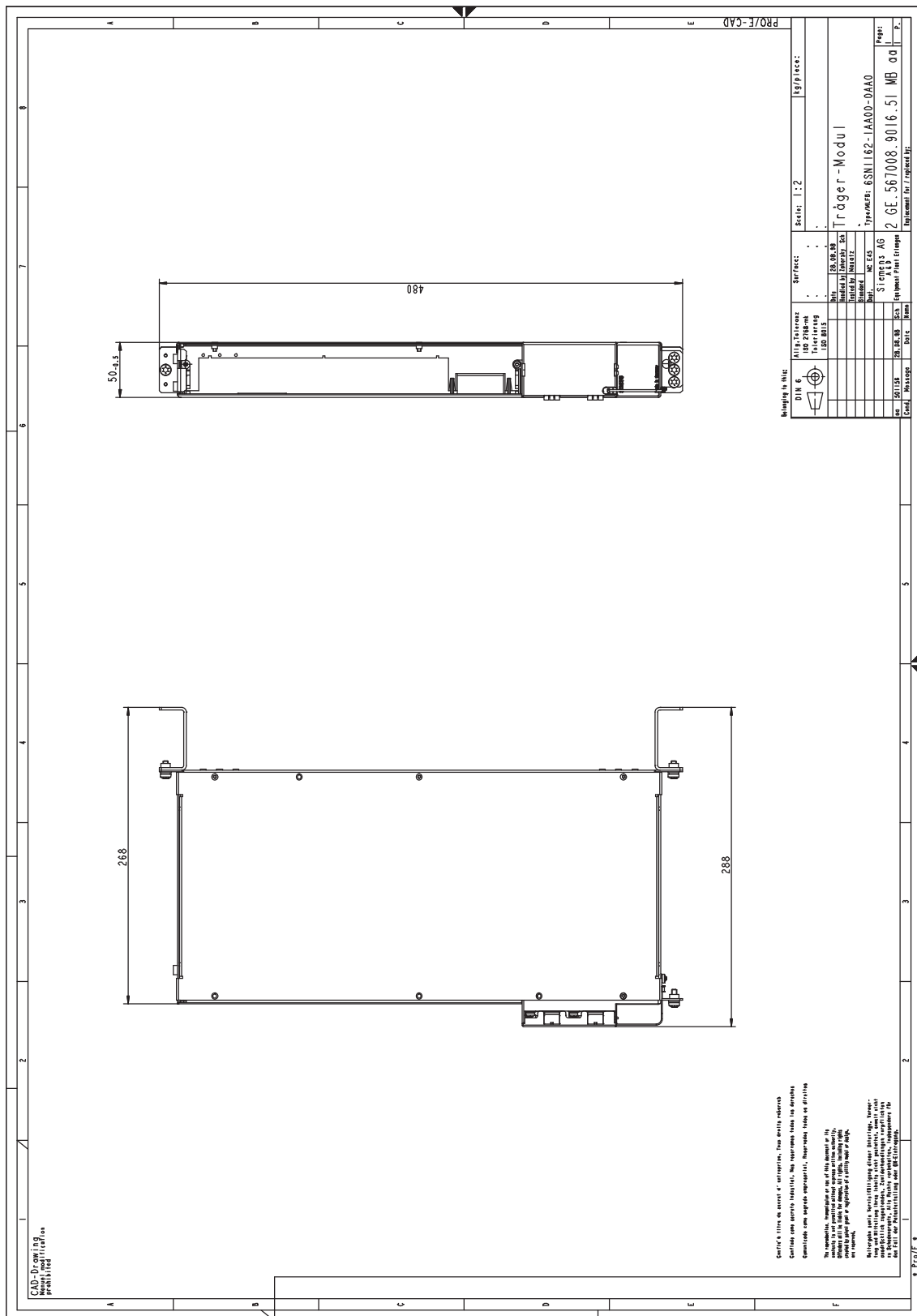

Fig. 12-1 Empty housing, Order No.: 6SN1162-1AA00-0AA0

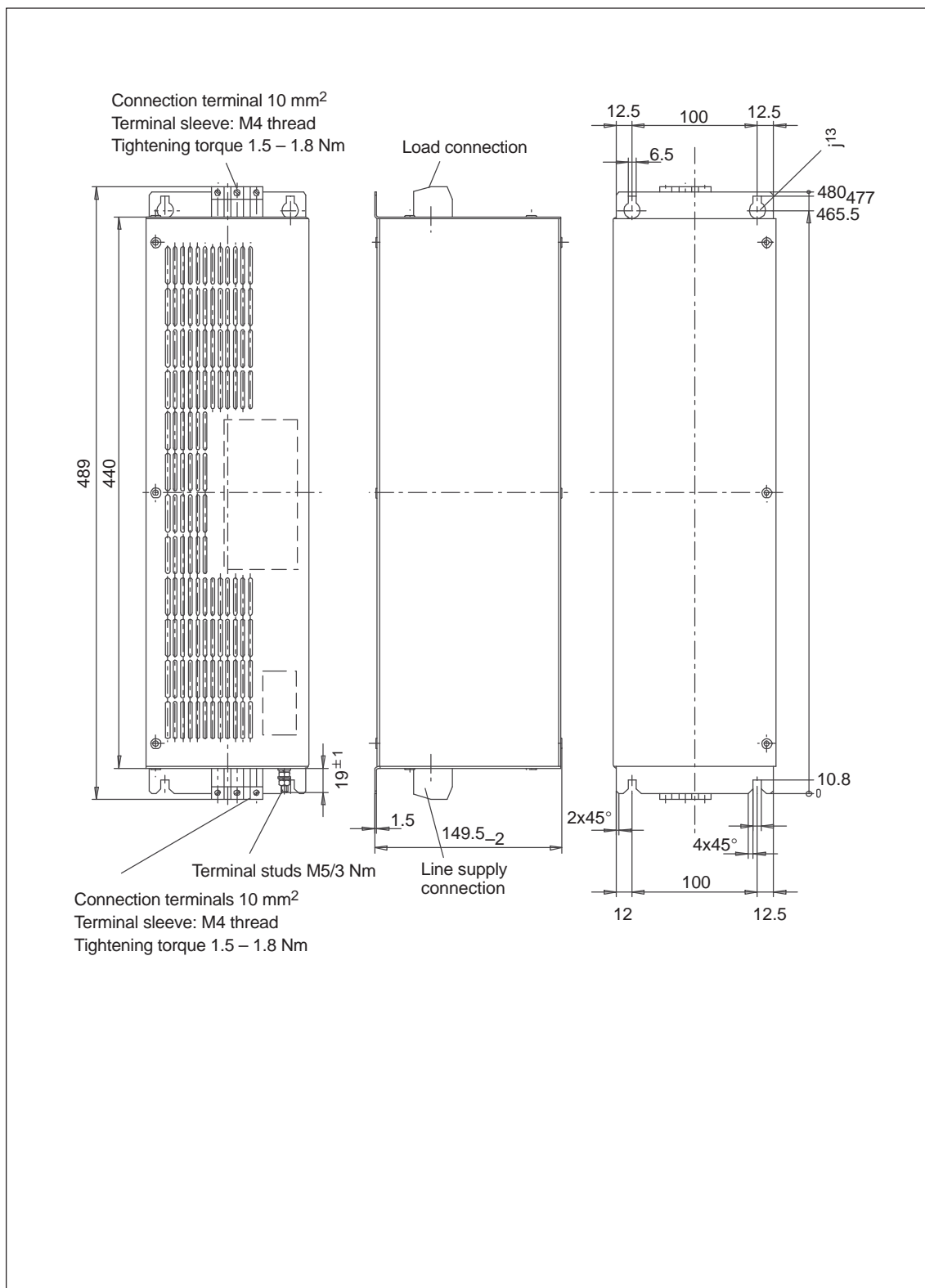

Fig. 12-2 Line filter "Wideband line filter" for I/R modules, 16 kW, 6SL3000-0BE21-6AAx

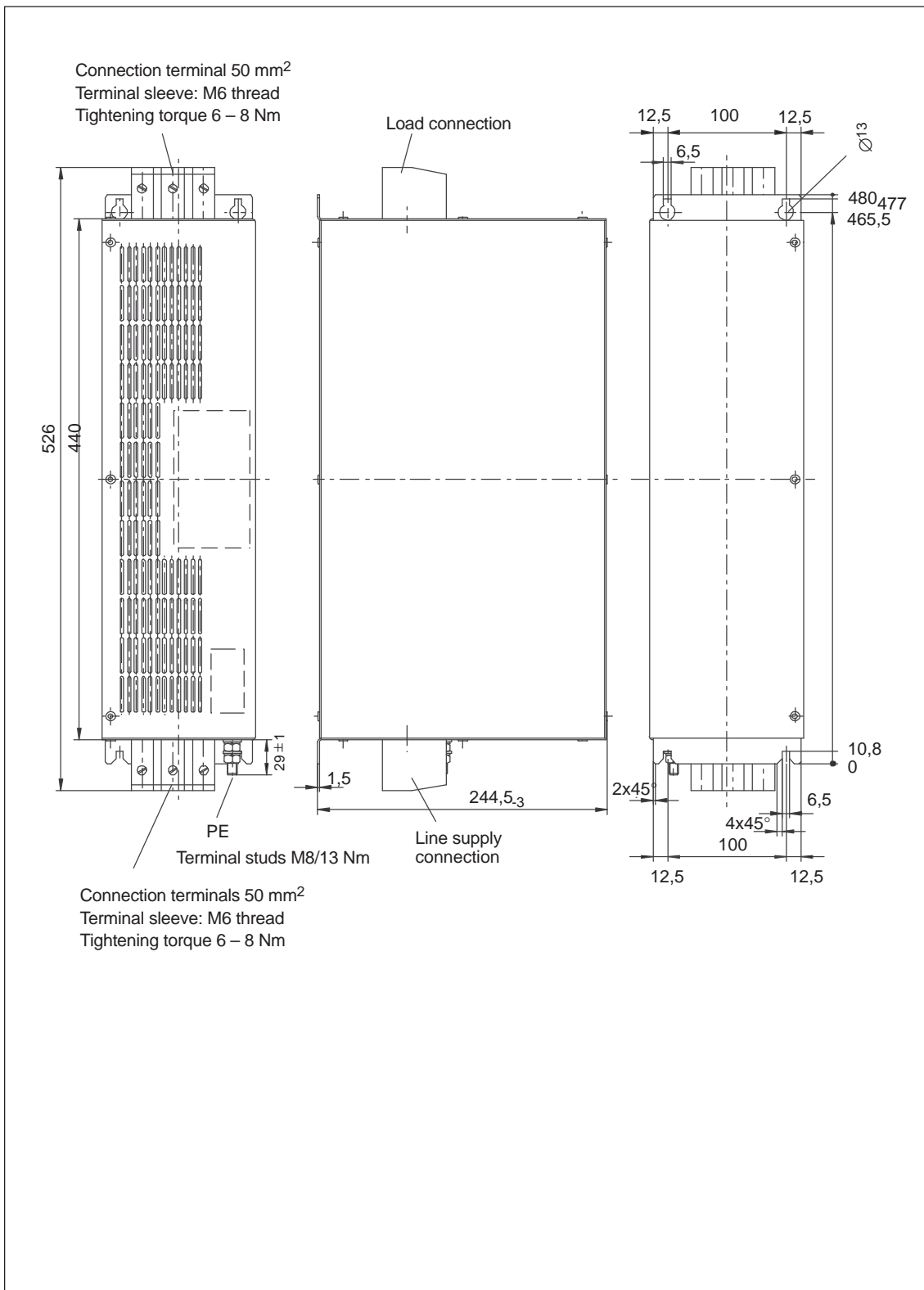

Fig. 12-3 Line filter "Wideband line filter" for I/R modules, 36 kW, 6SL3000-0BE23-6AAx

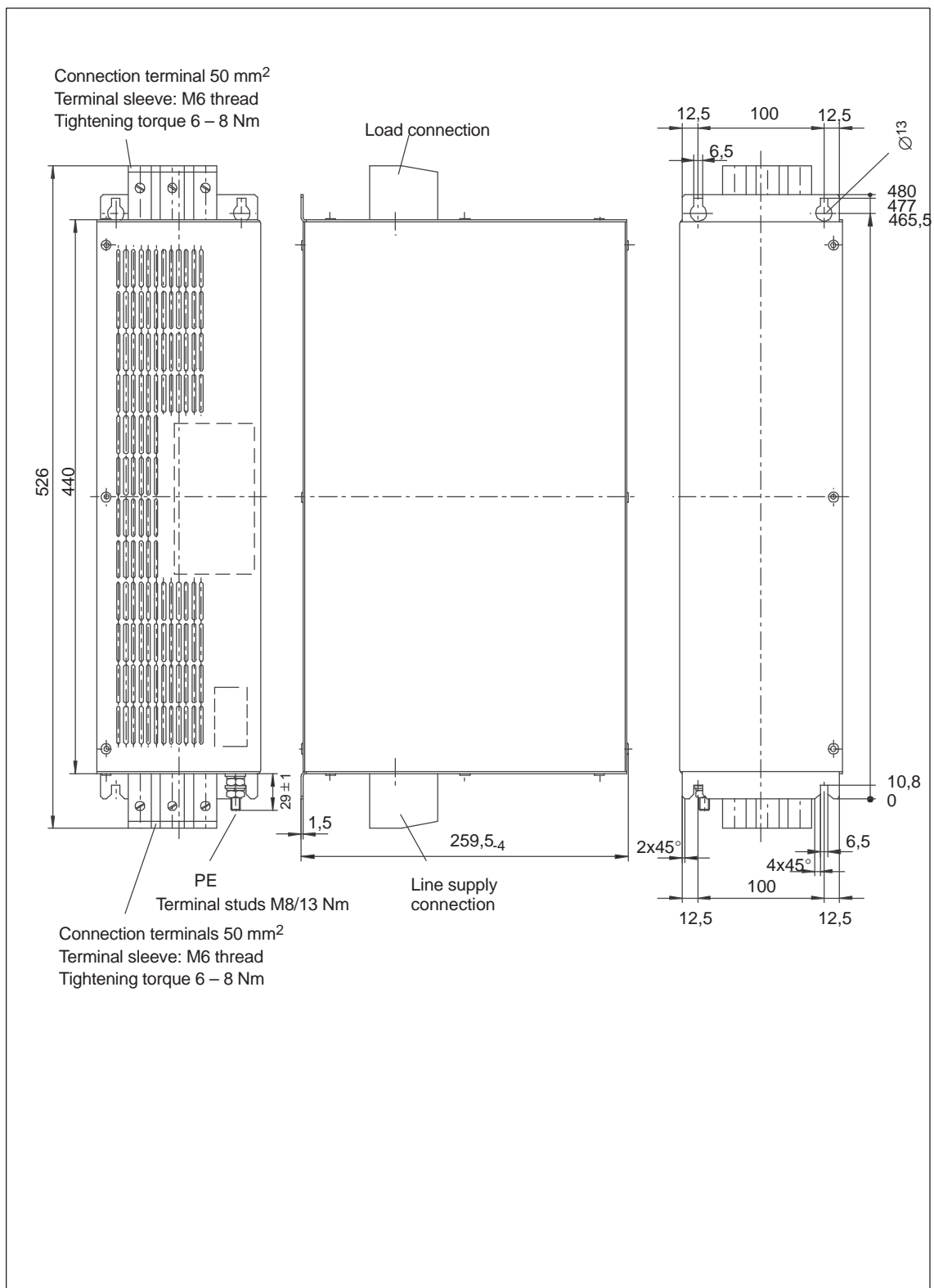

Fig. 12-4 Line filter "Wideband line filter" for I/R modules, 55 kW, 6SL3000-0BE25-5AAx

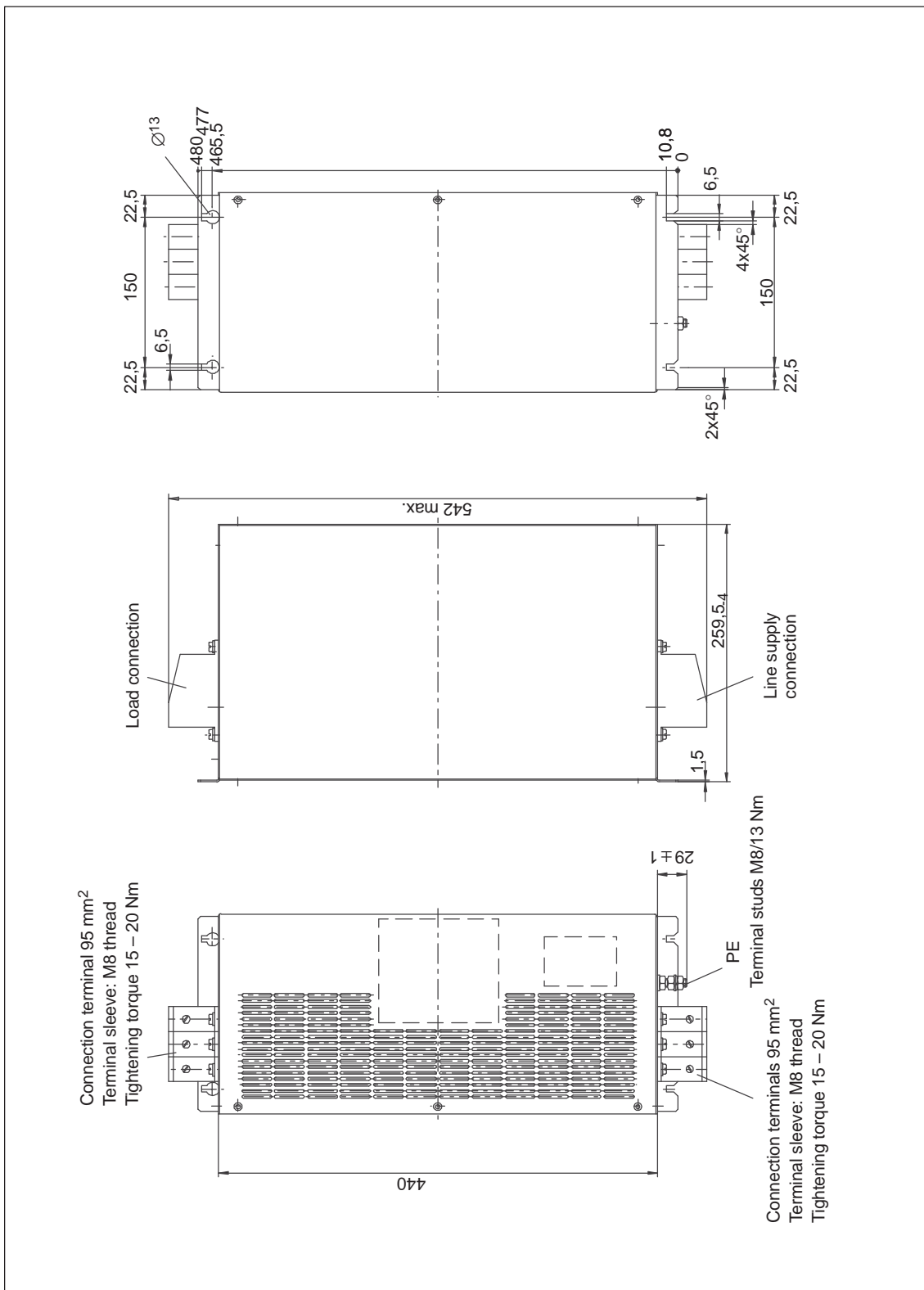

Fig. 12-5 Line filter "Wideband line filter" for I/R modules, 80 kW, 6SL3000-0BE28-0AAx

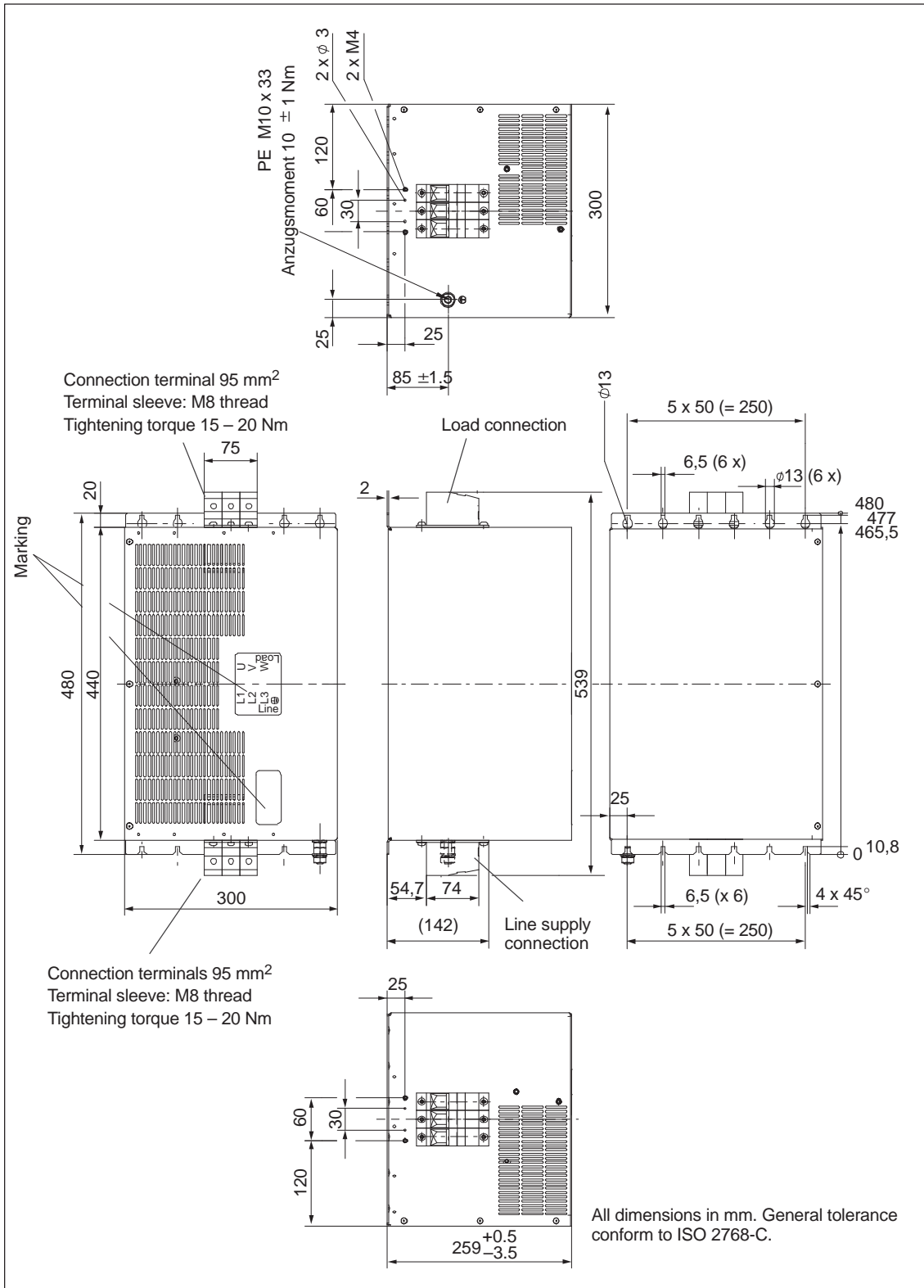

Fig. 12-6 Line filter "Wideband line filter" for I/R modules, 120 kW, 6SL3000-0BE31-2AAx



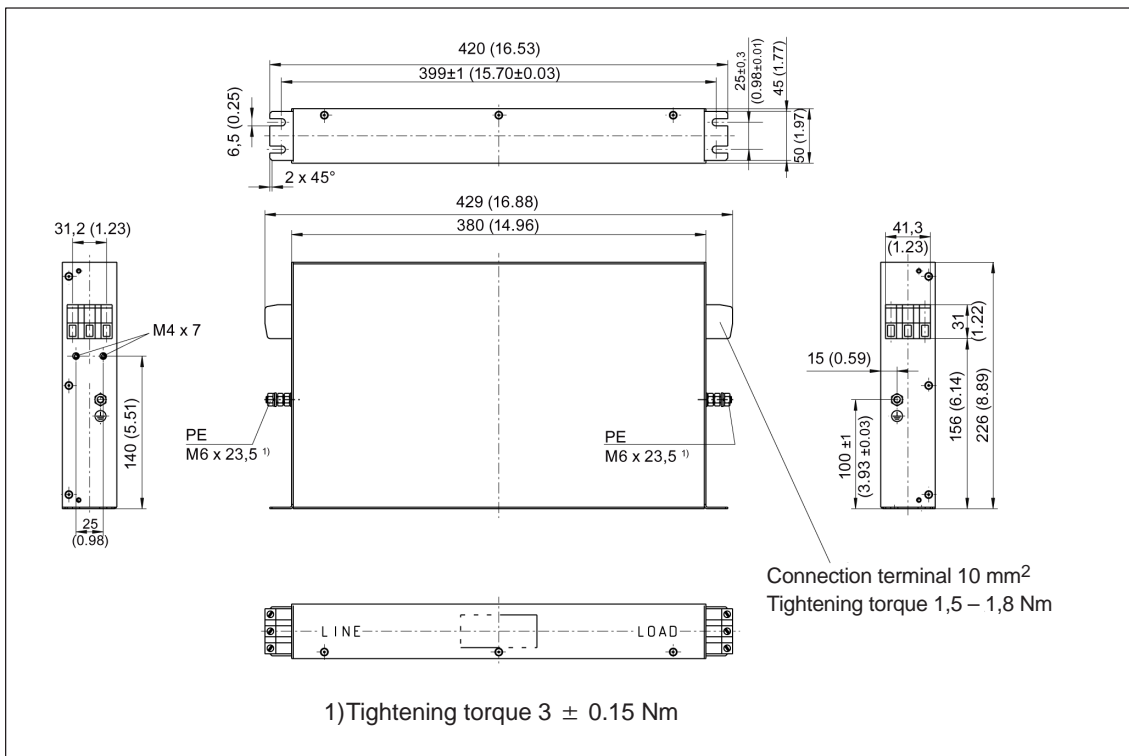

Fig. 12-7 Line filter "Basic line filter" for I/R modules 16 kW, 6SL3000-0BE21-6DAx

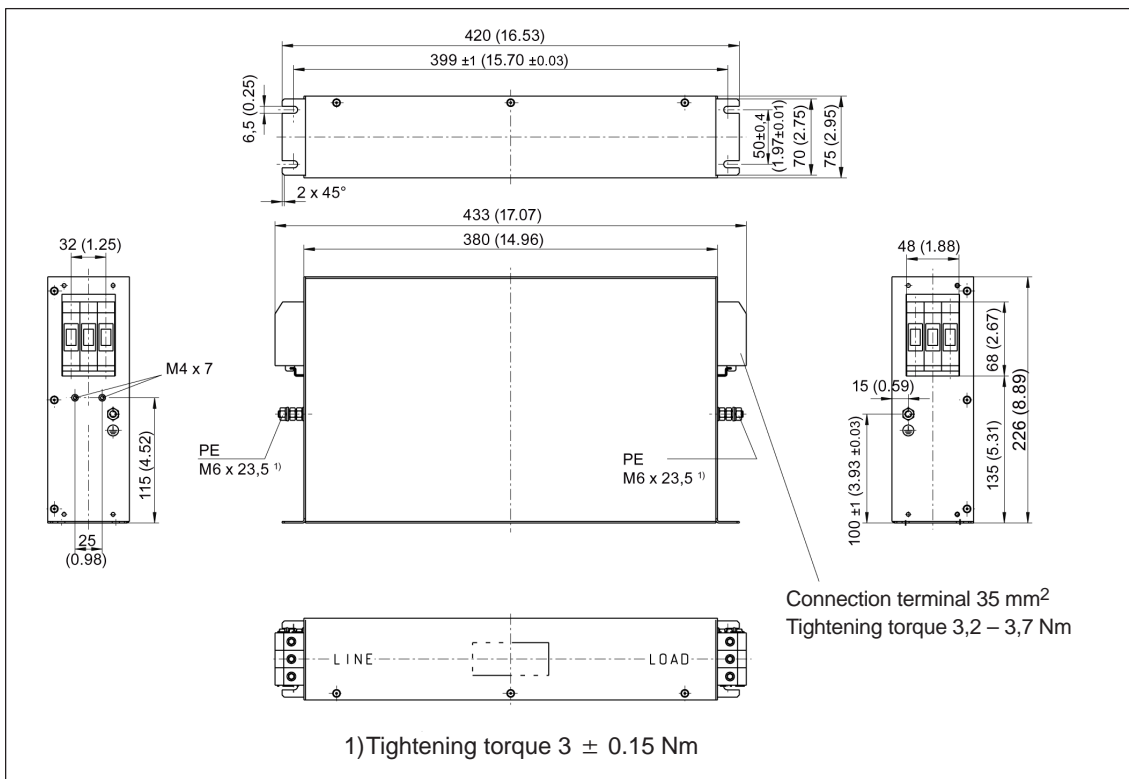

Fig. 12-8 Line filter "Basic line filter" for I/R modules 36 kW, 6SL3000-0BE23-6DAx

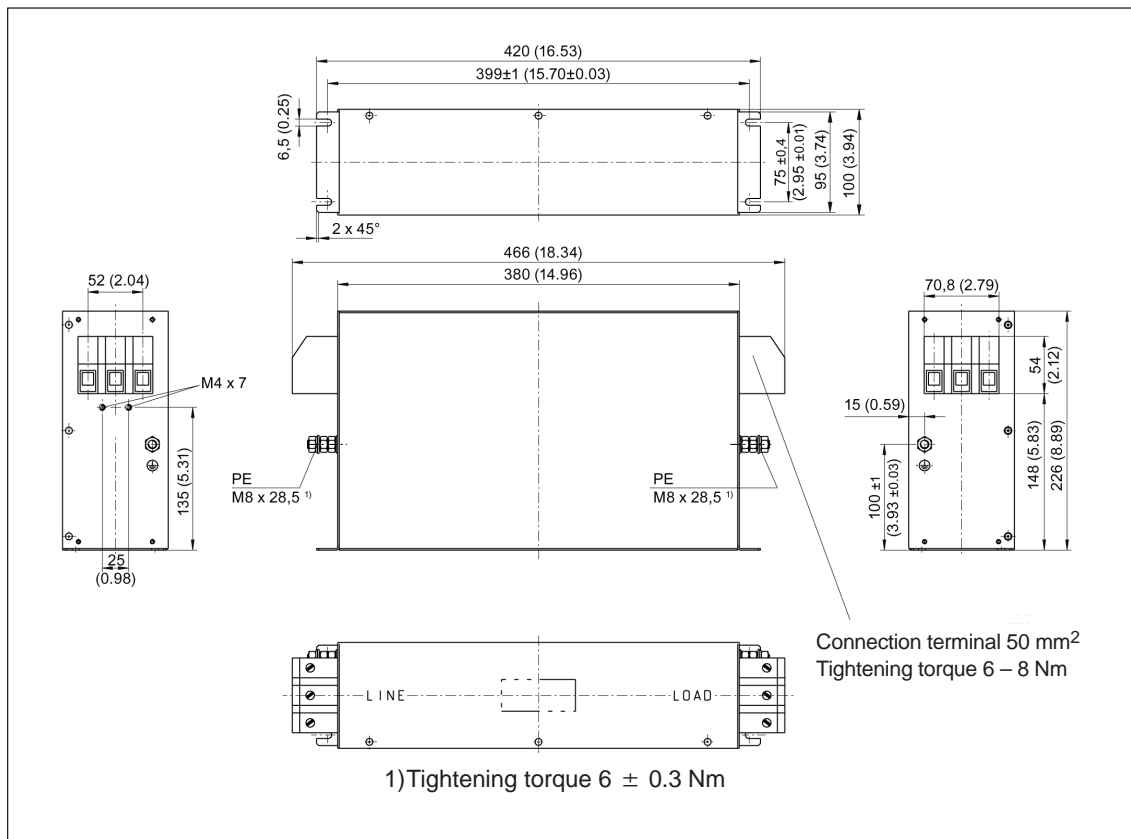

Fig. 12-9 Line filter "Basic line filter" for I/R modules 55 kW, 6SL3000-0BE25-5DAx

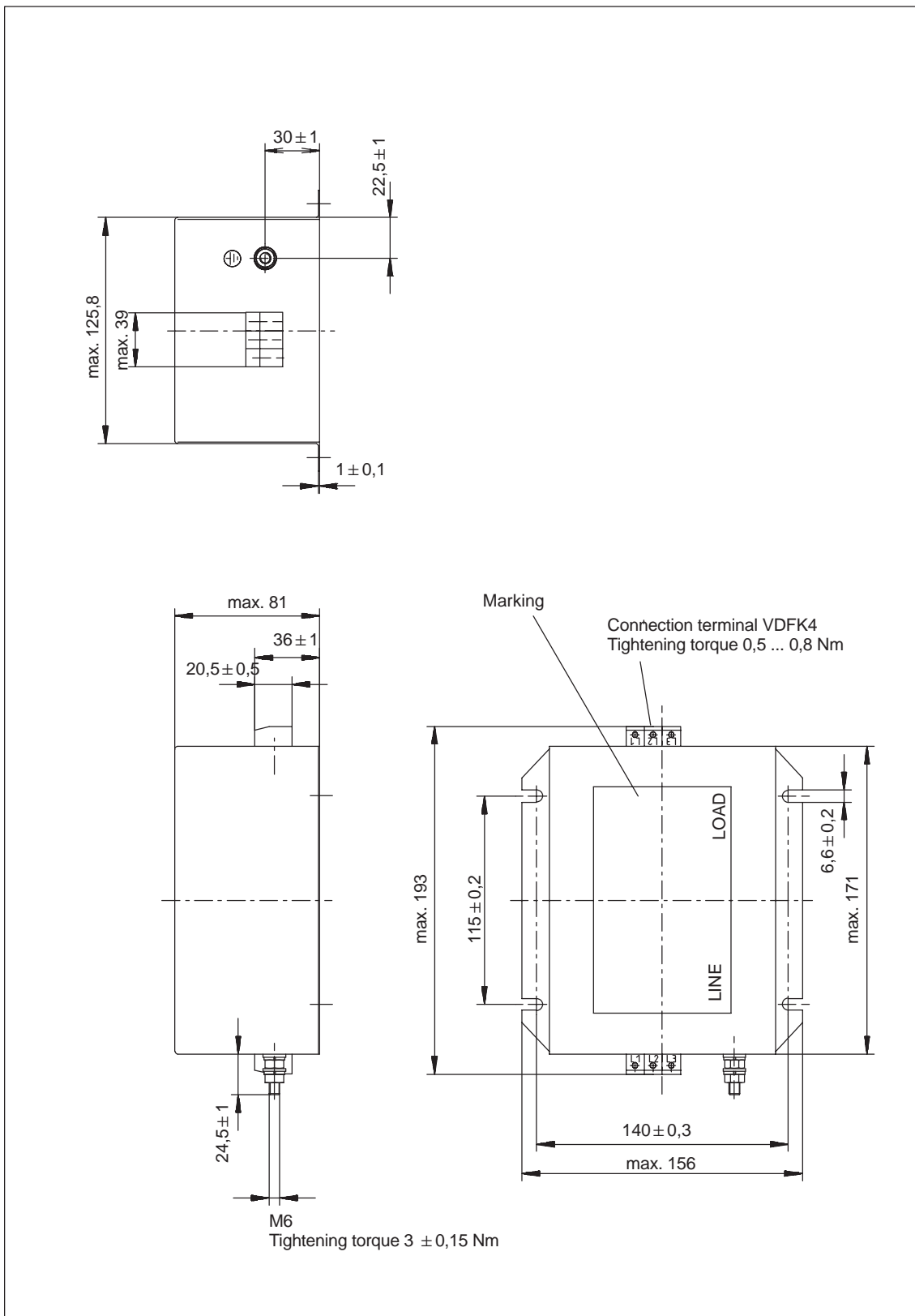

Fig. 12-10 Line filter for UI modules, 5 kW, 6SN1111-0AA01-1BA1

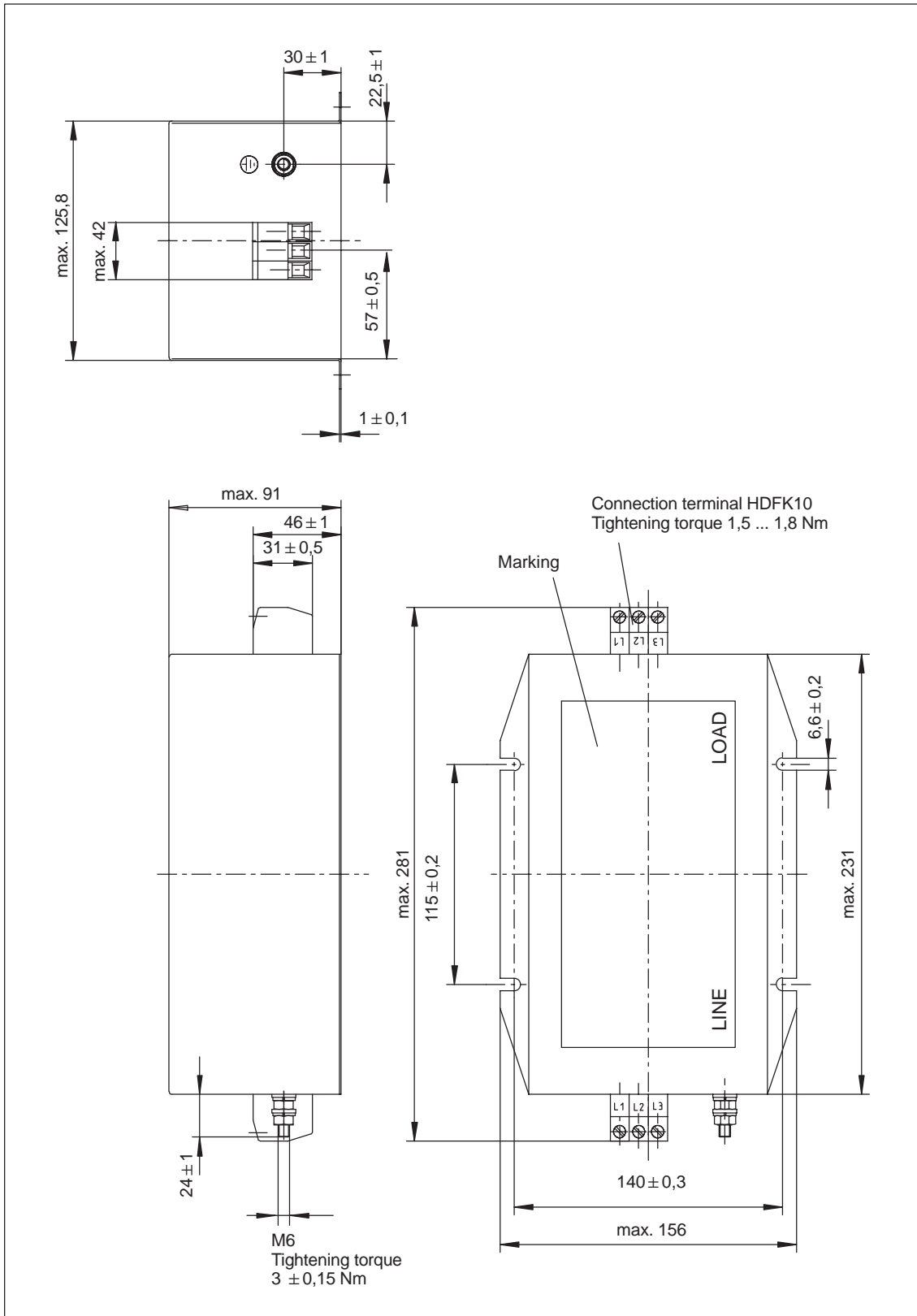

Fig. 12-11 Line filter for UI modules, 10 kW, 6SN1111-0AA01-1AA1

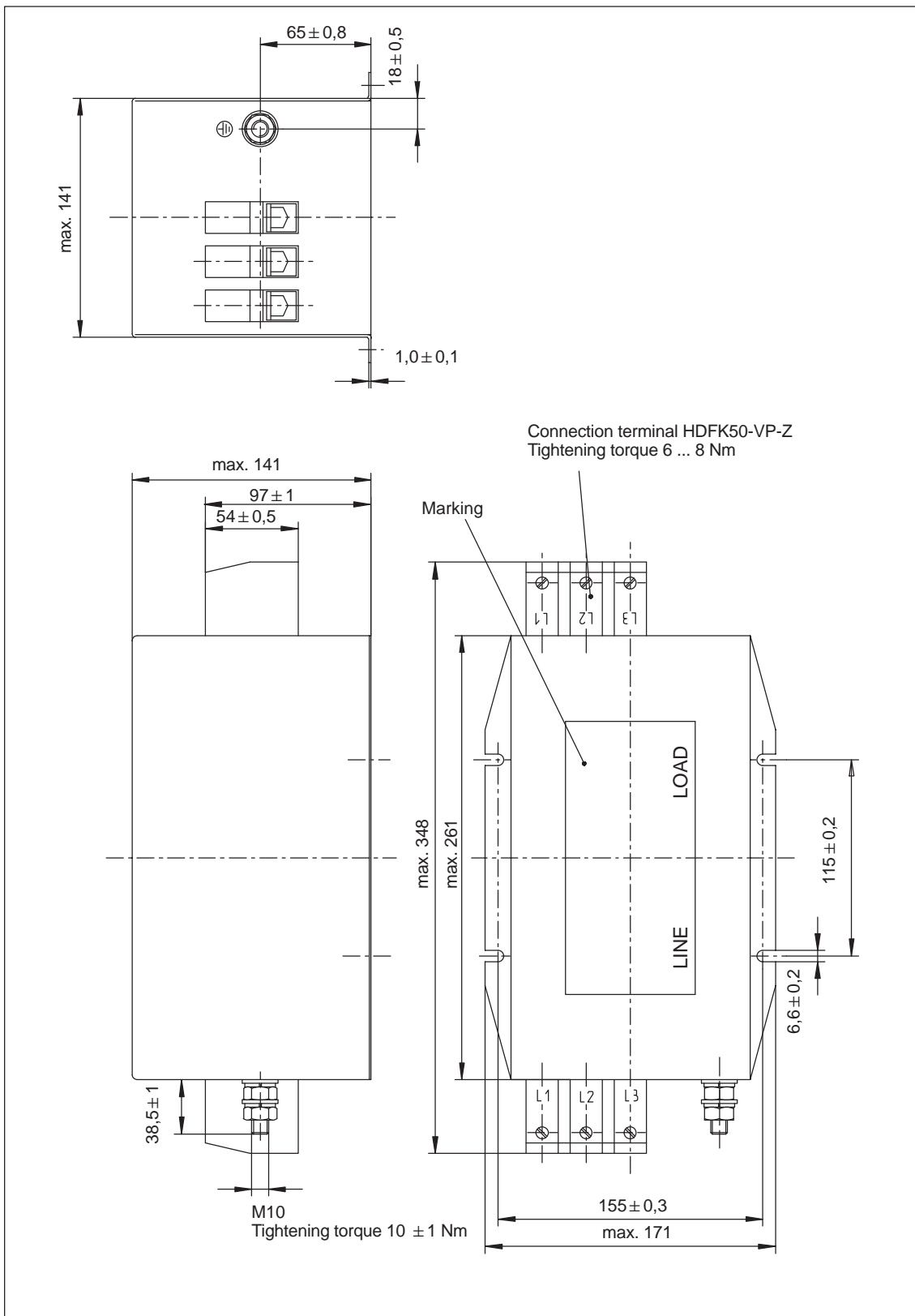

Fig. 12-12 Line filter for UI modules, 28 kW, 6SN1111-0AA01-1CA1

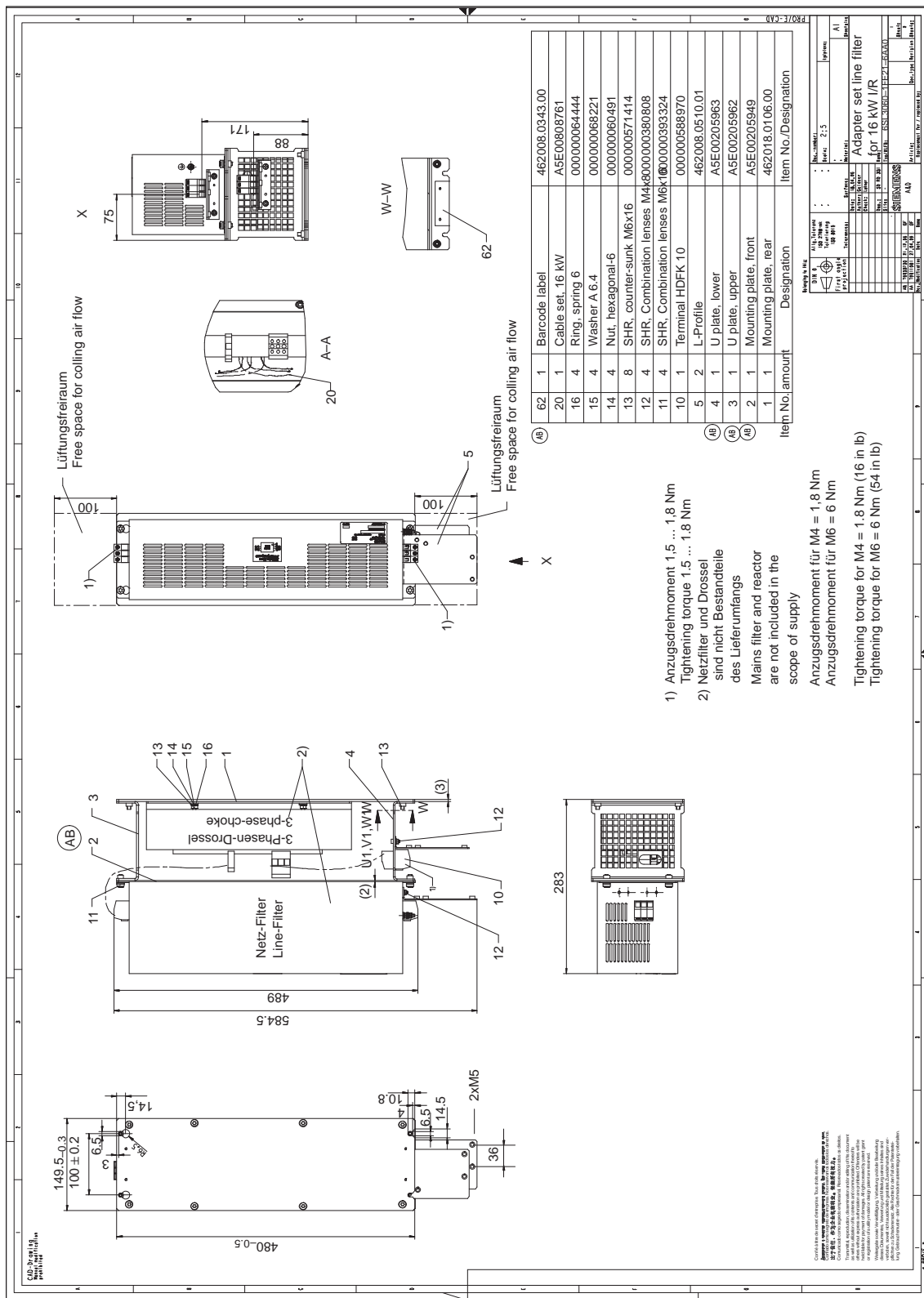

Fig. 12-13 Adapter set, line filter for I/R module 16 kW, 6SL3060-1FE21-6AAx; dimension drawing

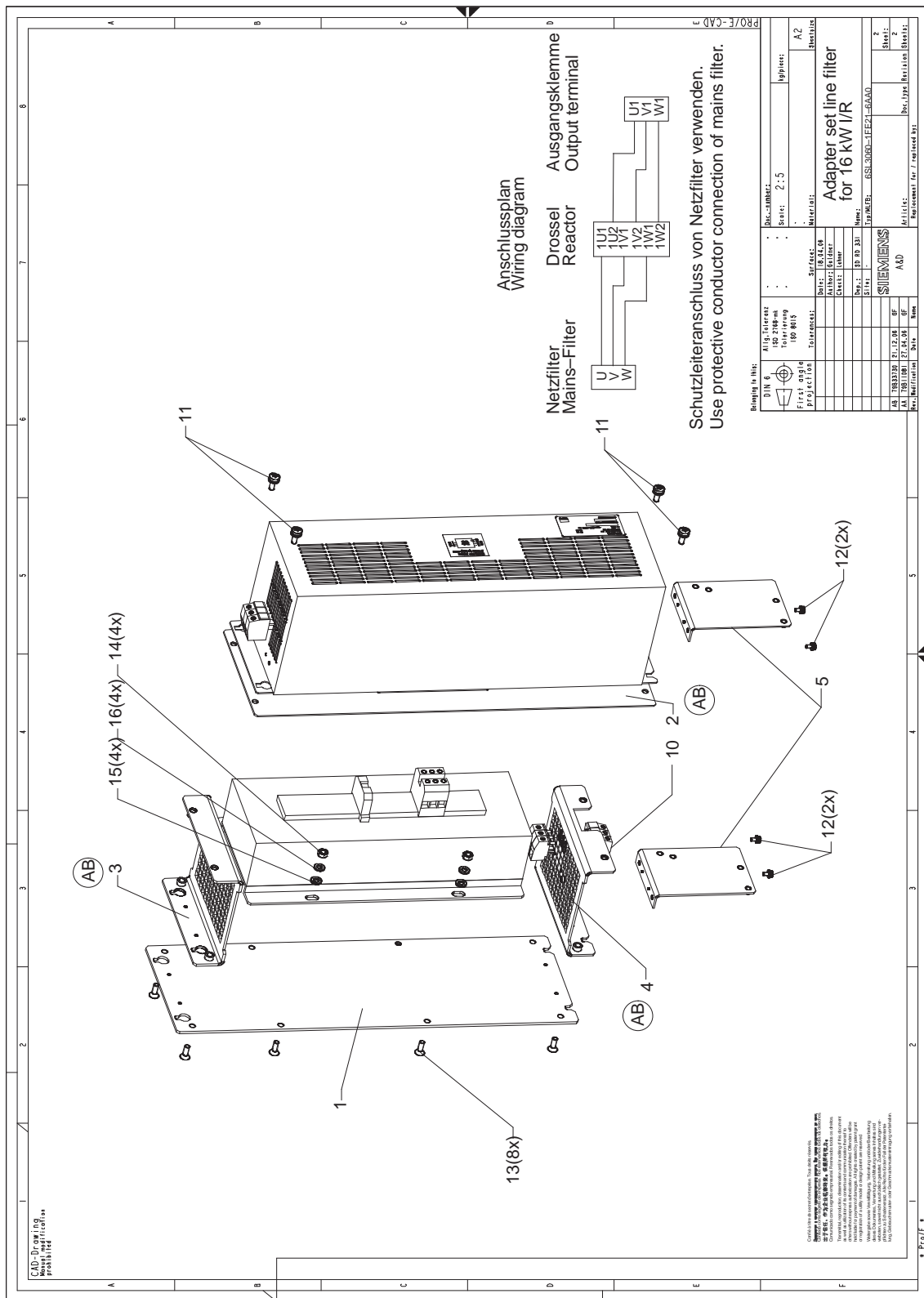

Fig. 12-14 Adapter set, line filter for I/R module 16 kW, 6SL3060-1FE21-6AAx; mounting

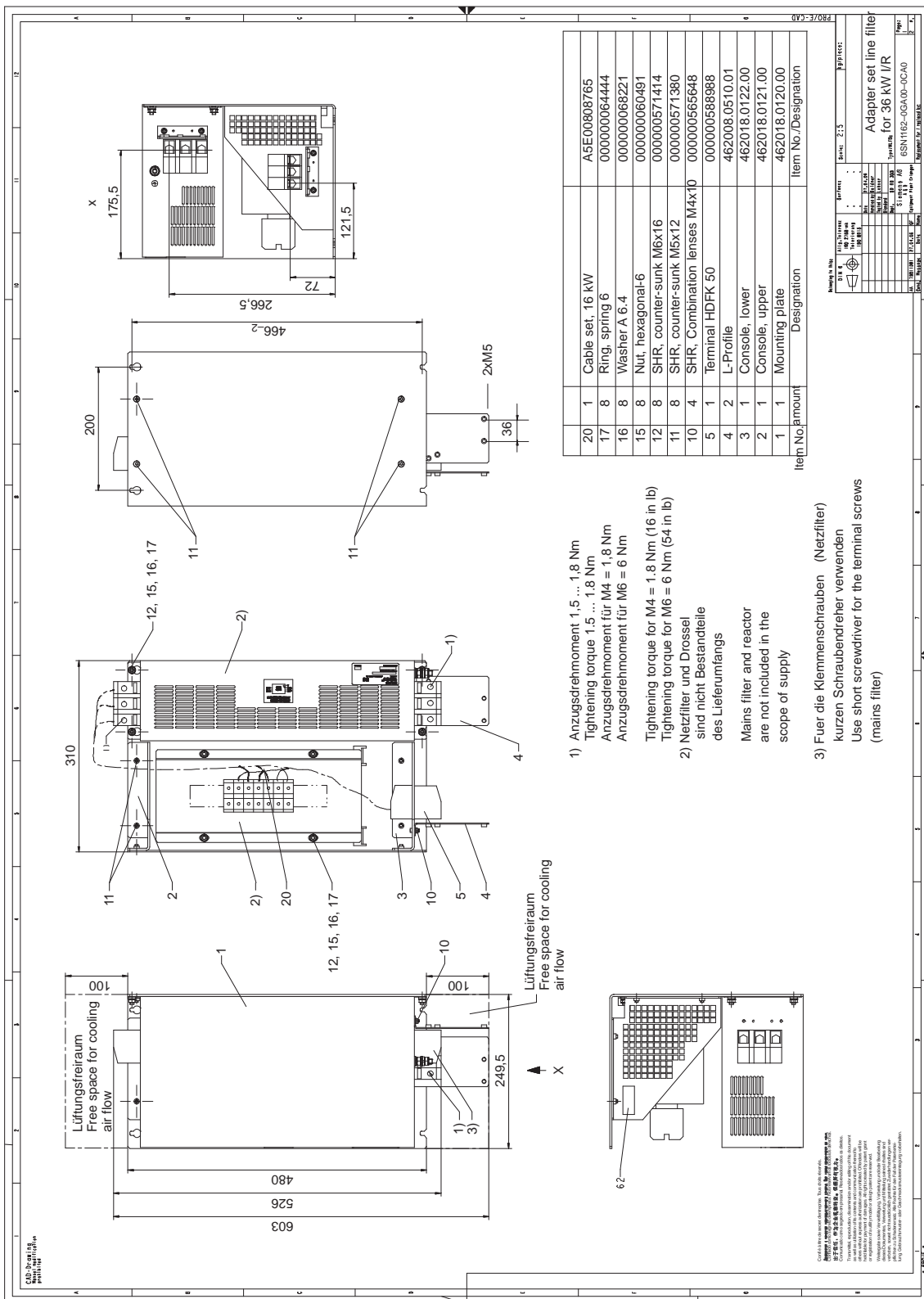

Fig. 12-15 Adapter set, line filter for I/R module 36 kW, 6SN1162-0GA00-0CAx; dimension drawing



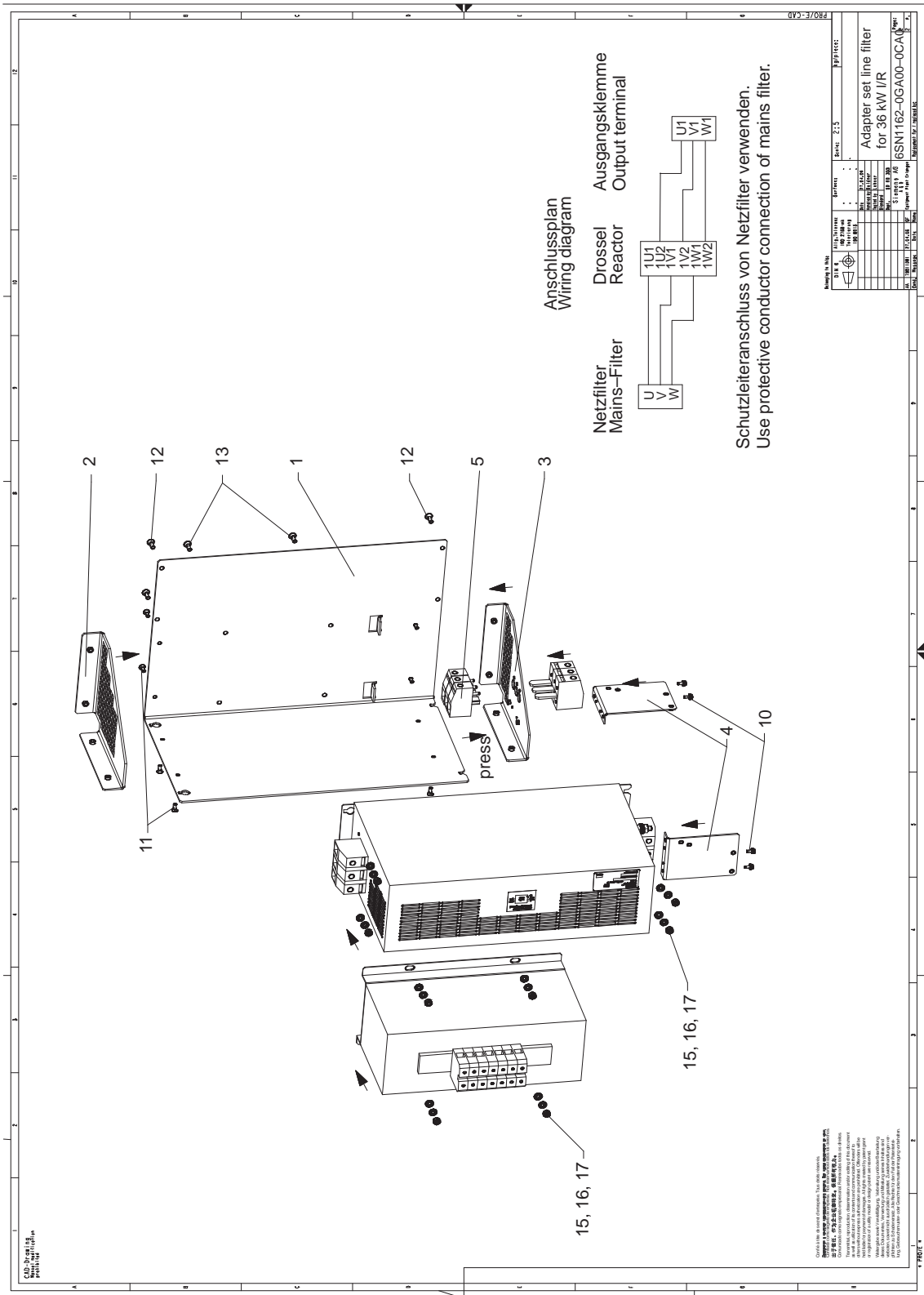

Fig. 12-16 Adapter set, line filter for I/R module 36 kW, 6SN1162-0GA00-0CAx; mounting

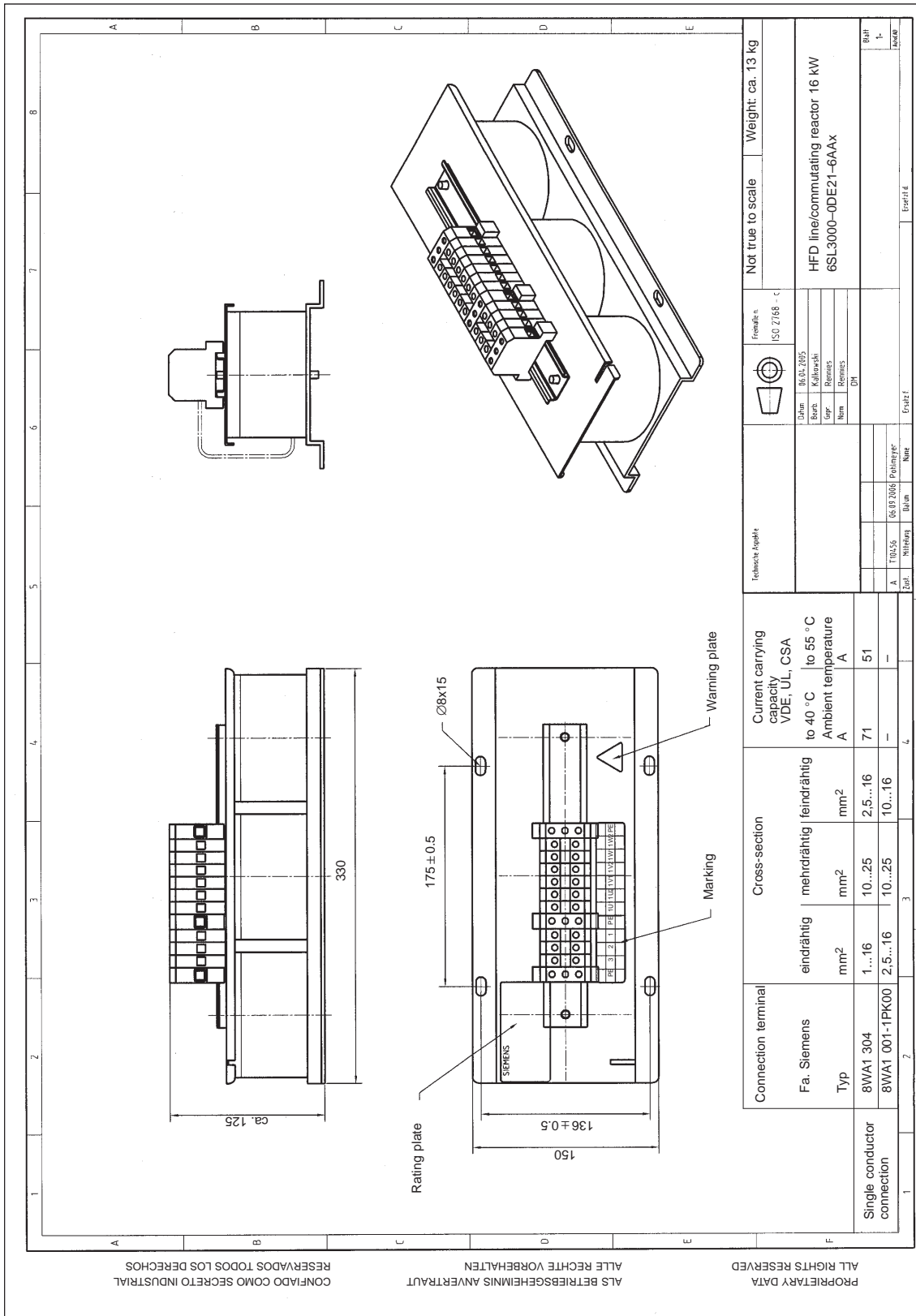

Fig. 12-17 3-phase HFD line/commutating reactor 16 kW, 6SL3000-0DE21-6AAx

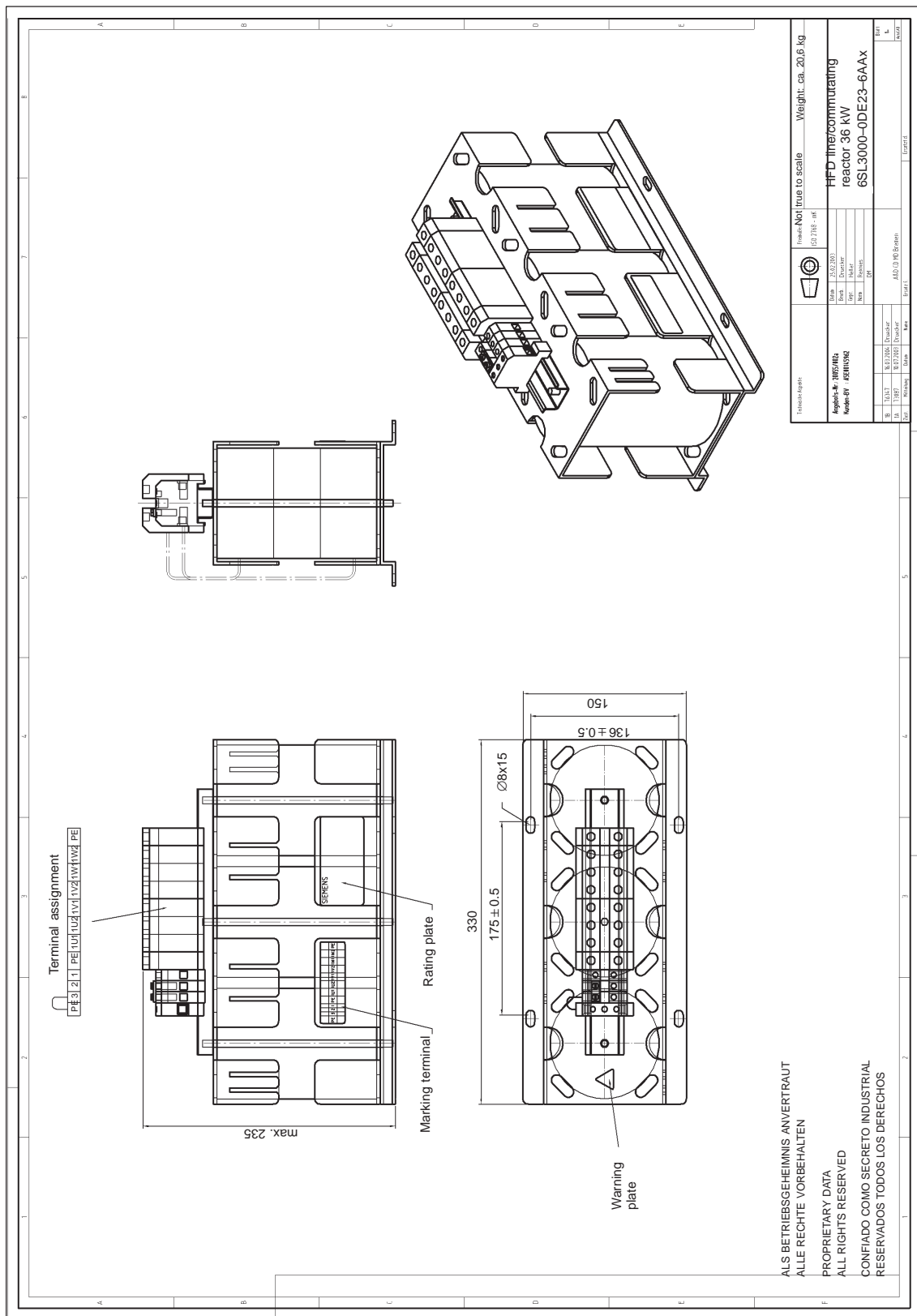

Fig. 12-18 3-phase HFD line/commutating reactor 36 kW, 6SL3000-0DE23-6AAx

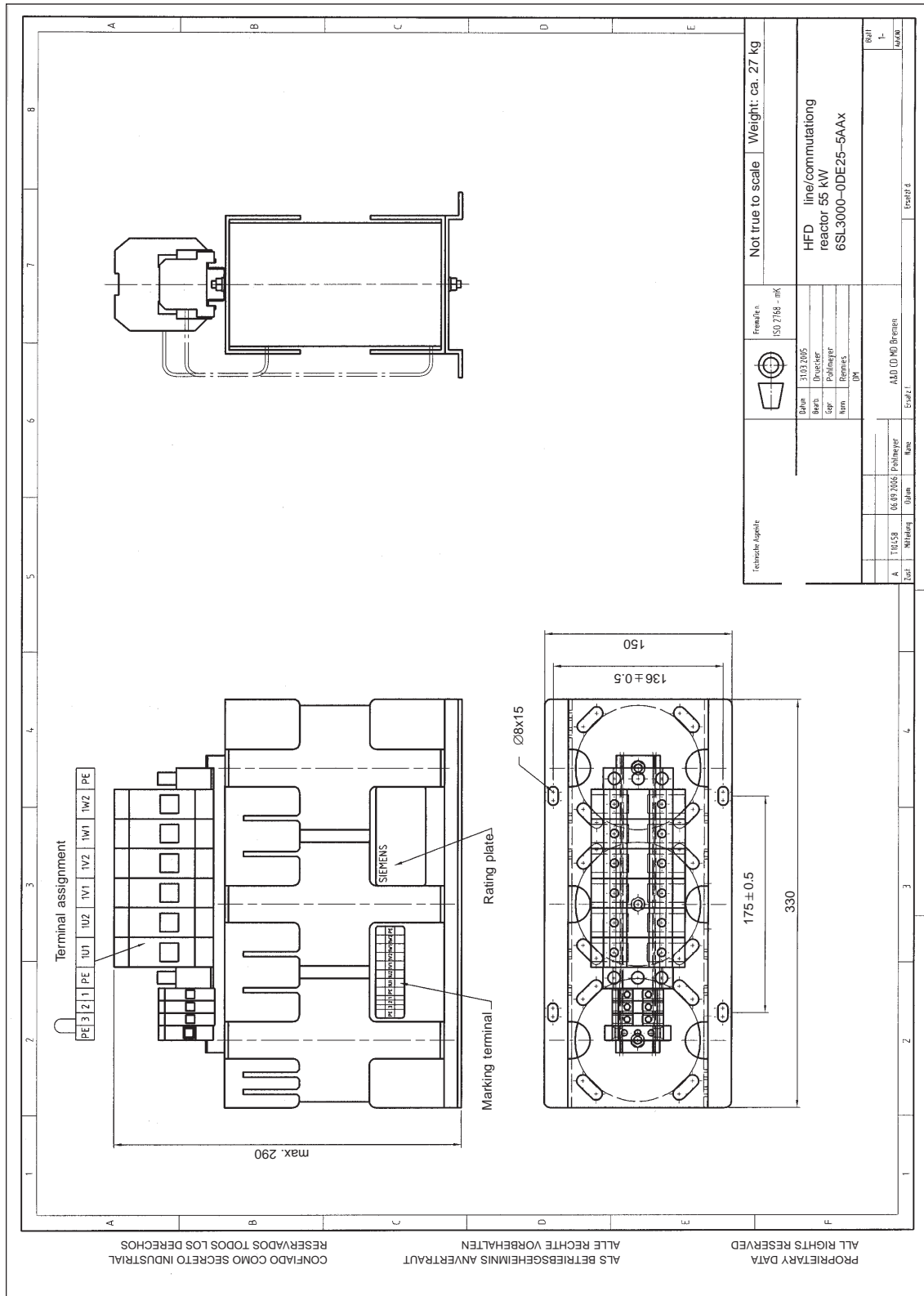

Fig. 12-19 3-phase HFD line/commutating reactor 55 kW, 6SL3000-0DE25-5AAX

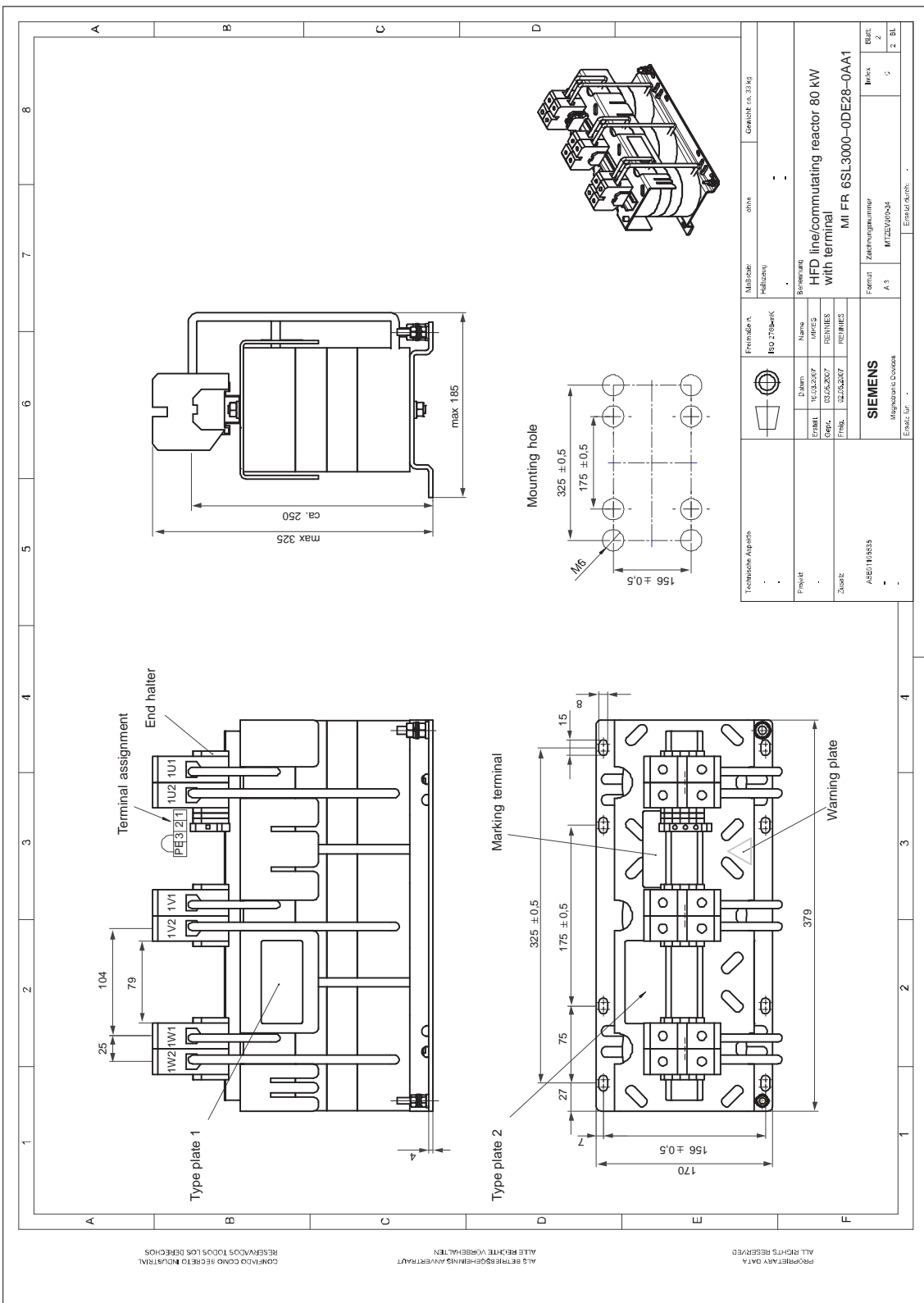

Fig. 12-20 3-phase HFD line/commutating reactor 80 kW, 6SL3000-0DE28-0AAx

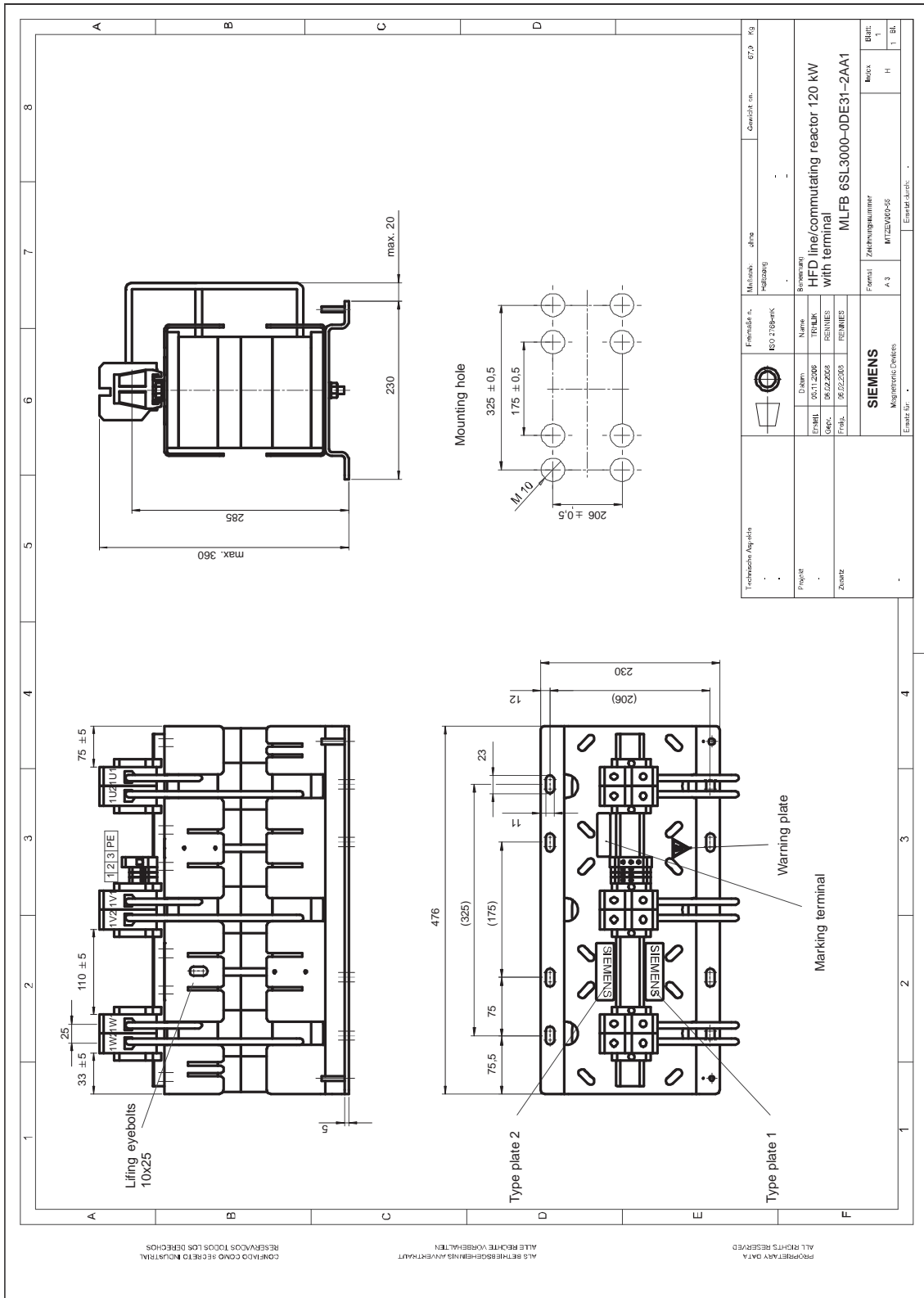

Fig. 12-21 3-phase HFD line/commutating reactor 120 kW, 6SL3000-0DE31-2AAx

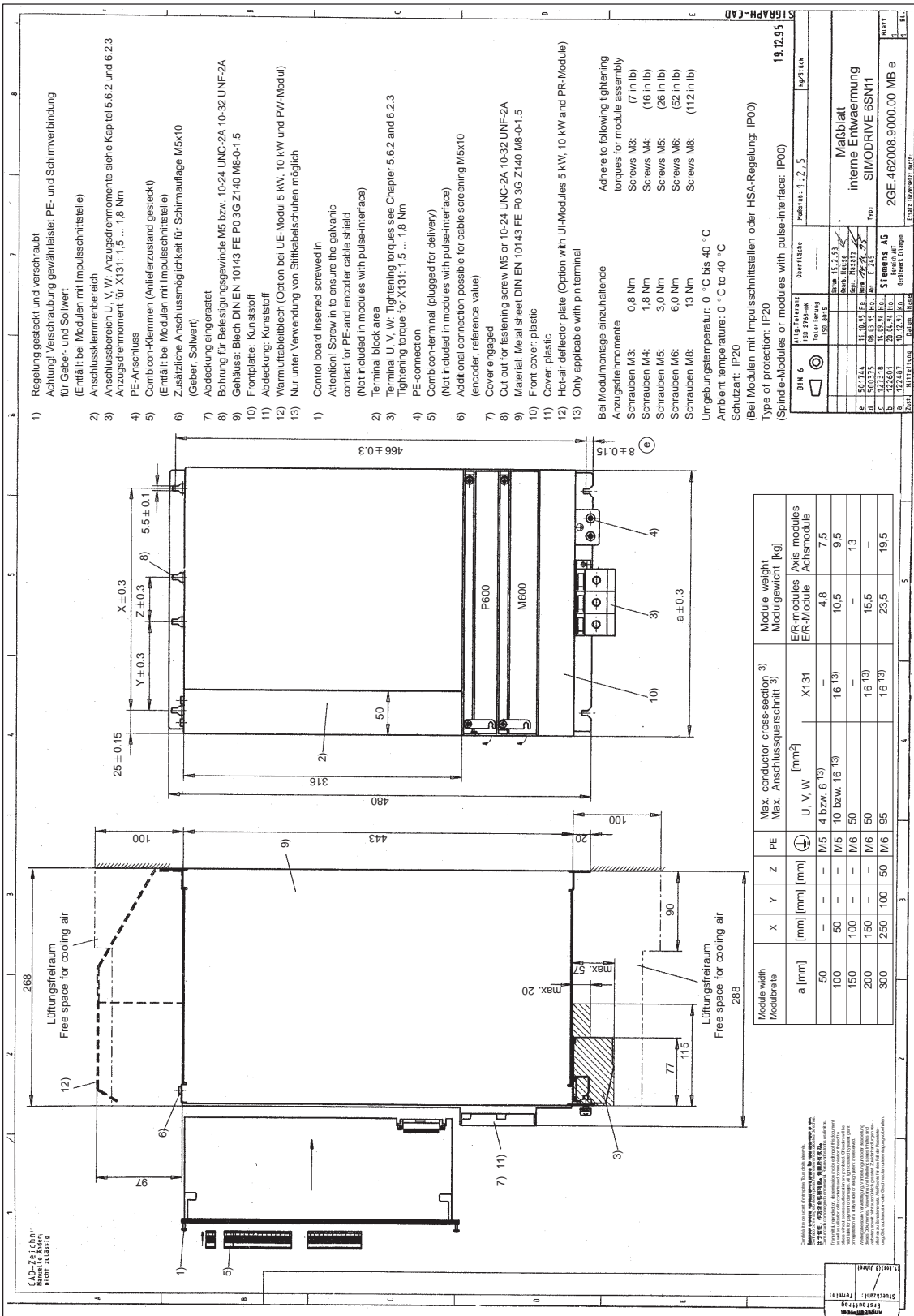

Fig. 12-22 Internal cooling, module width 50/100/150/200/300 mm





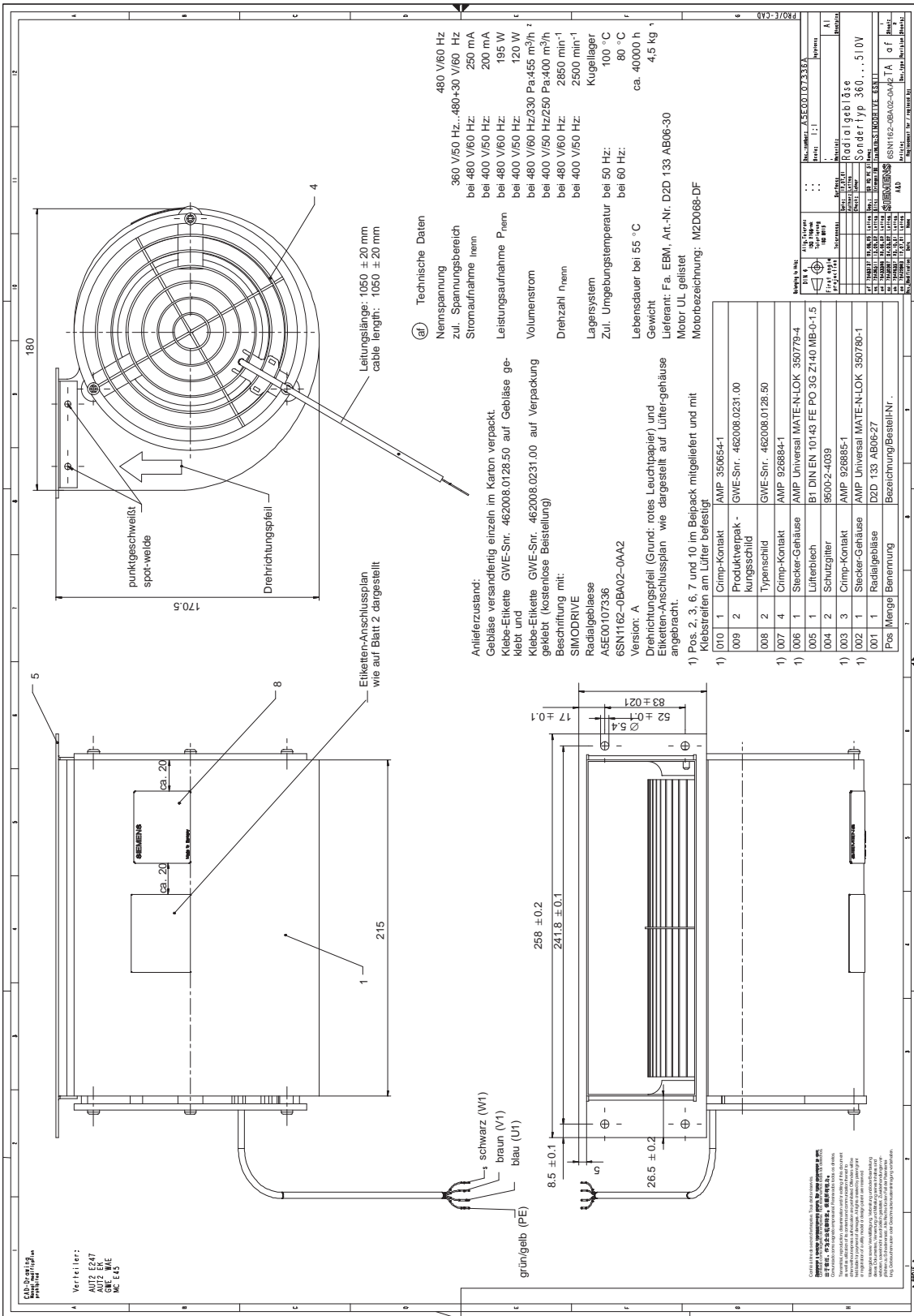

Fig. 12-24 Built-on fan, 6SN1162-0BA02-0AA2; dimension drawing

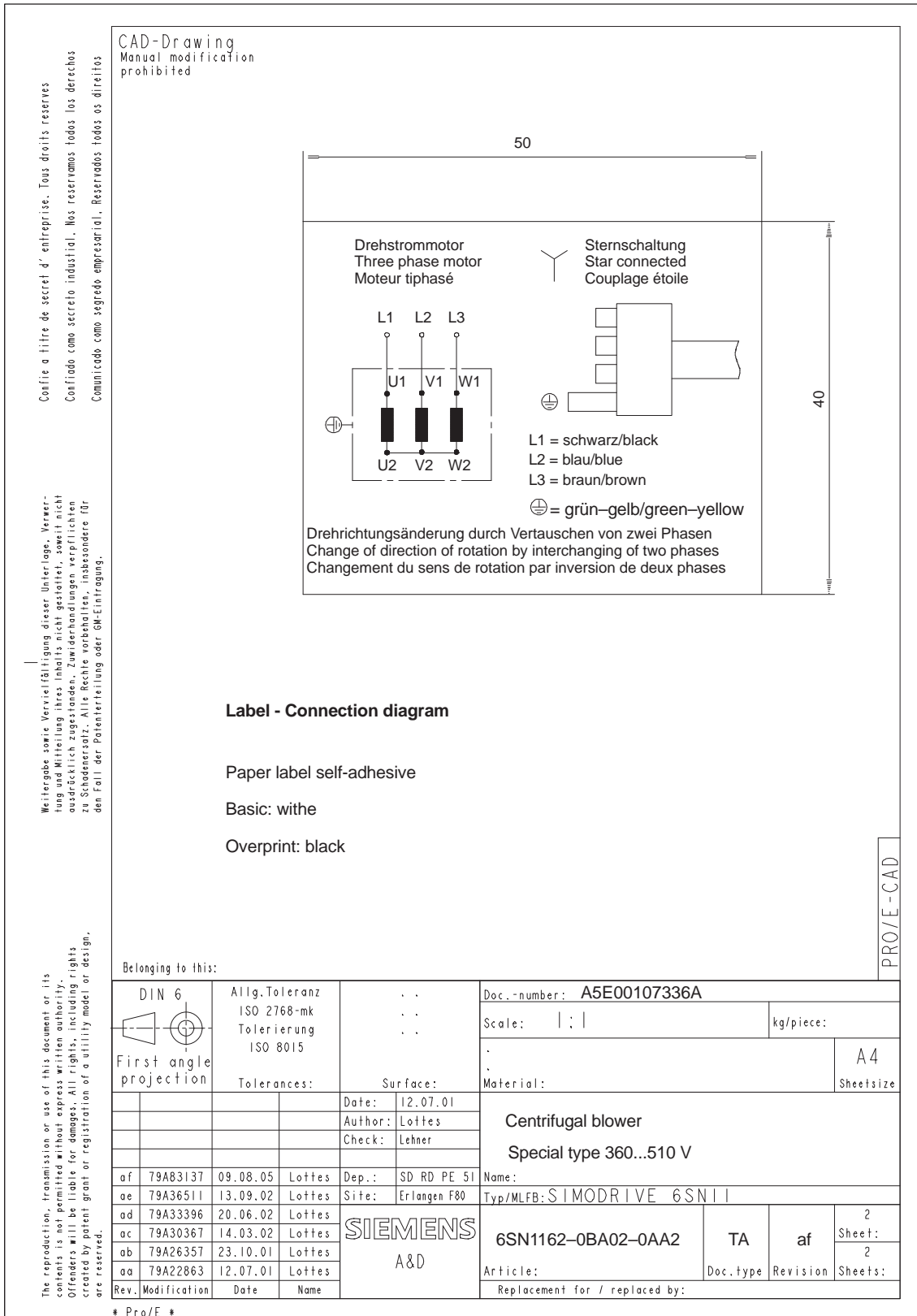

Fig. 12-25 Built-on fan, 6SN1162-0BA02-0AA2; connection diagram

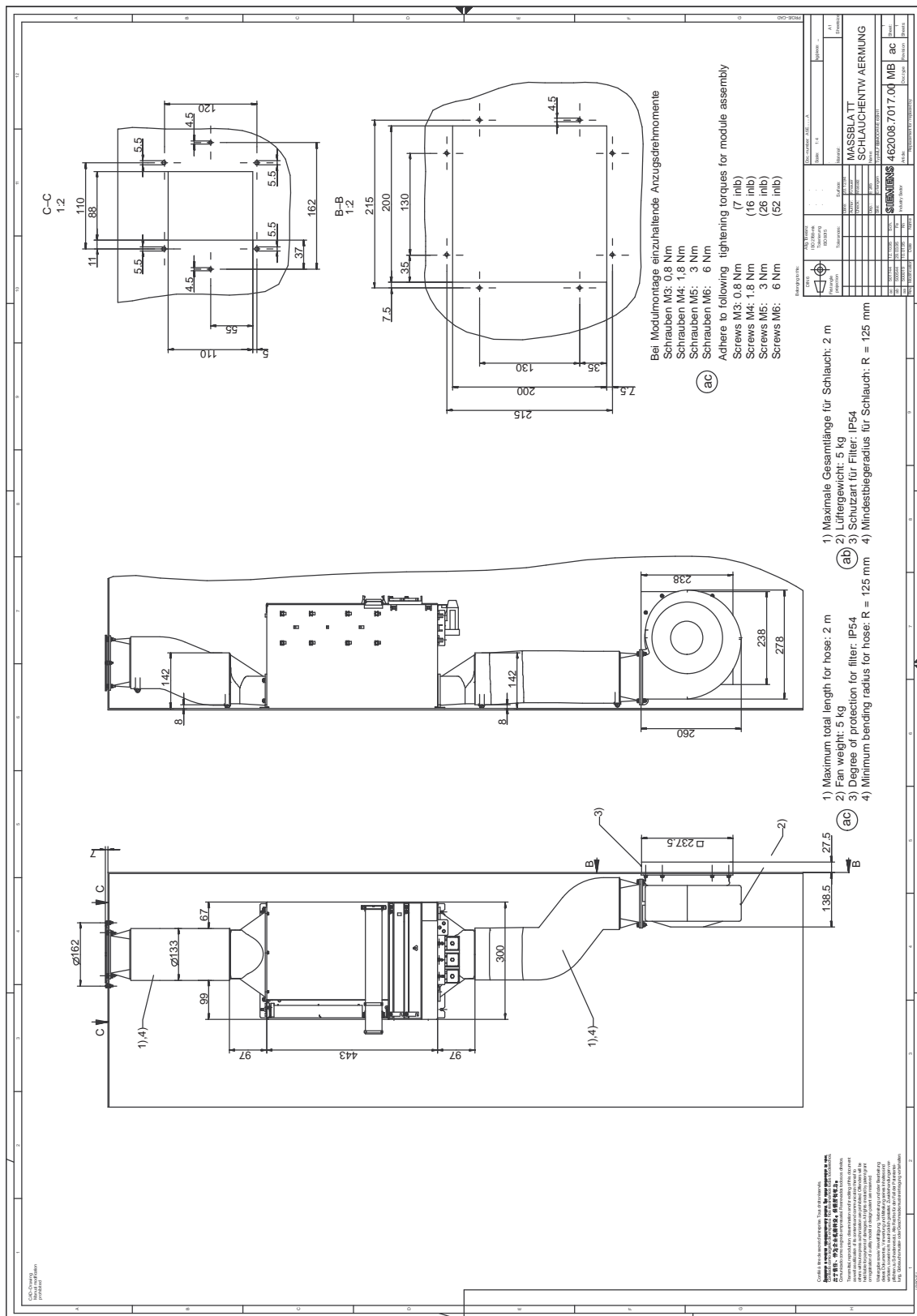

Fig. 12-26 Hose cooling for individual modules, 6SN1162-0BA03-0AA1

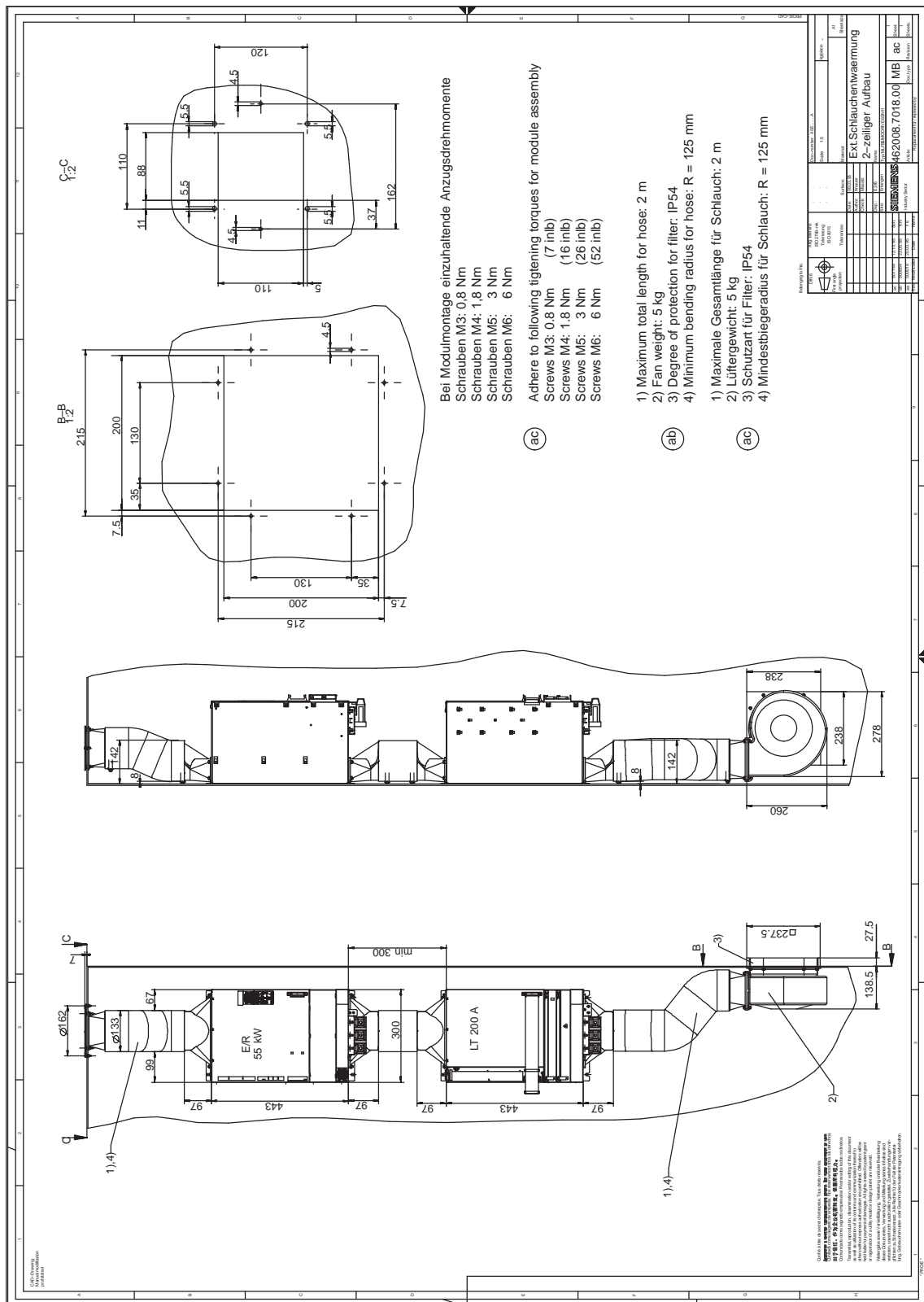

Fig. 12-27 Hose cooling for 2-tier configuration, 6SN1162-0BA03-0CA1

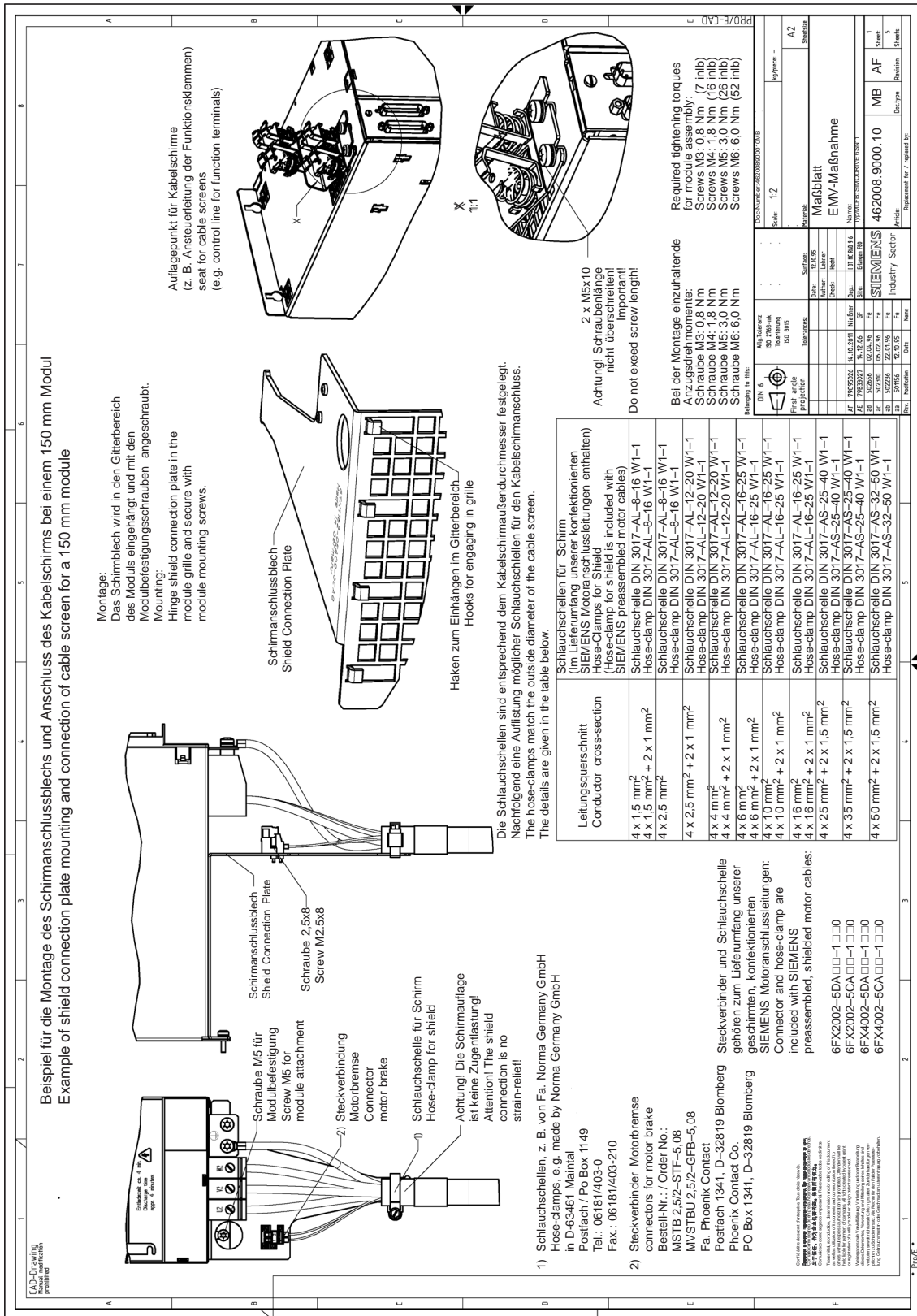

Fig. 12-28 EMC measures, Sheet 1 (example shield connection plate width 150 mm)

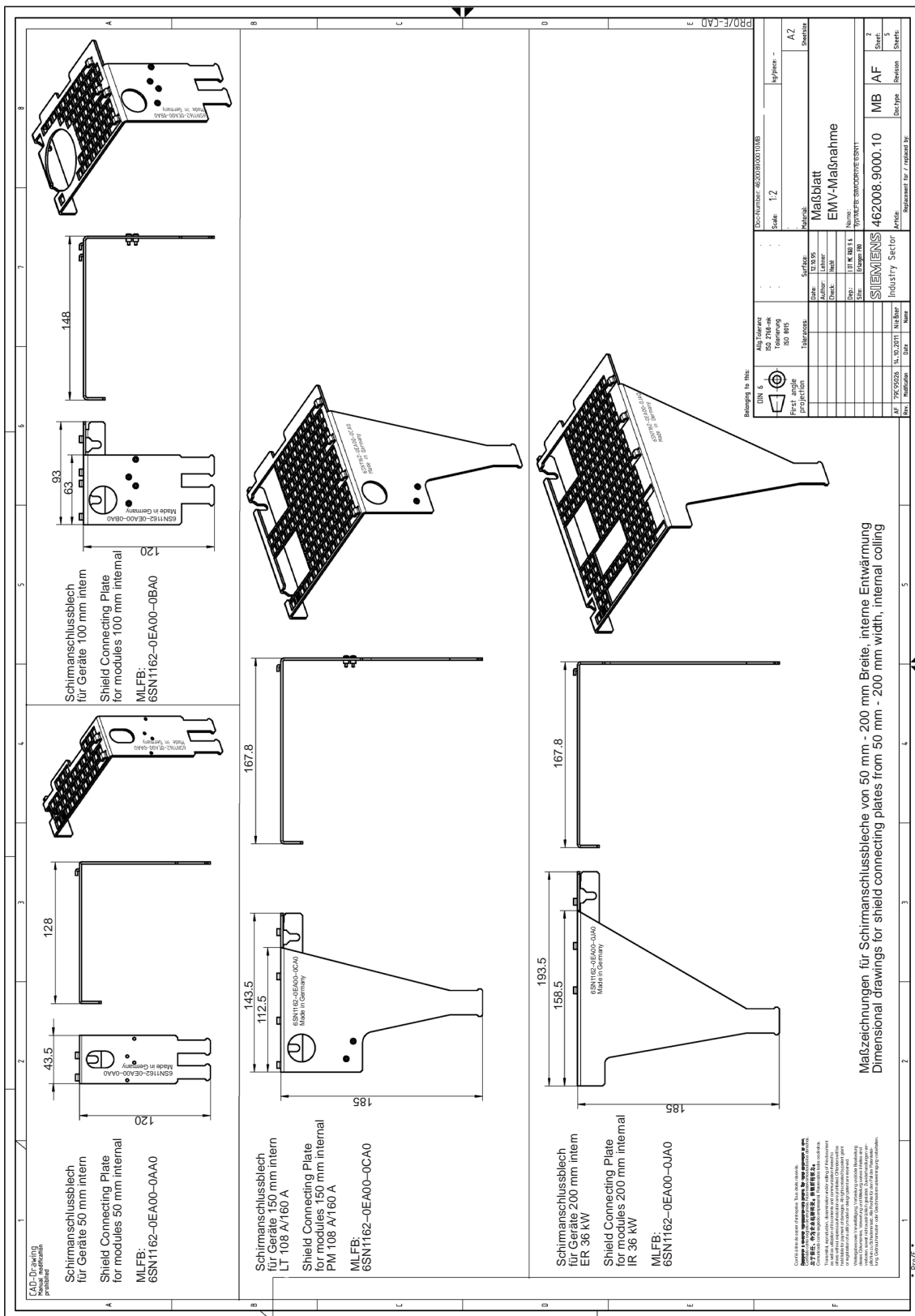

Fig. 12-29 EMC measures, Sheet 2 (shield connection plate, 6SN1162-0EA00-0AA0; -0BA0; -0CA0; -0JA0)

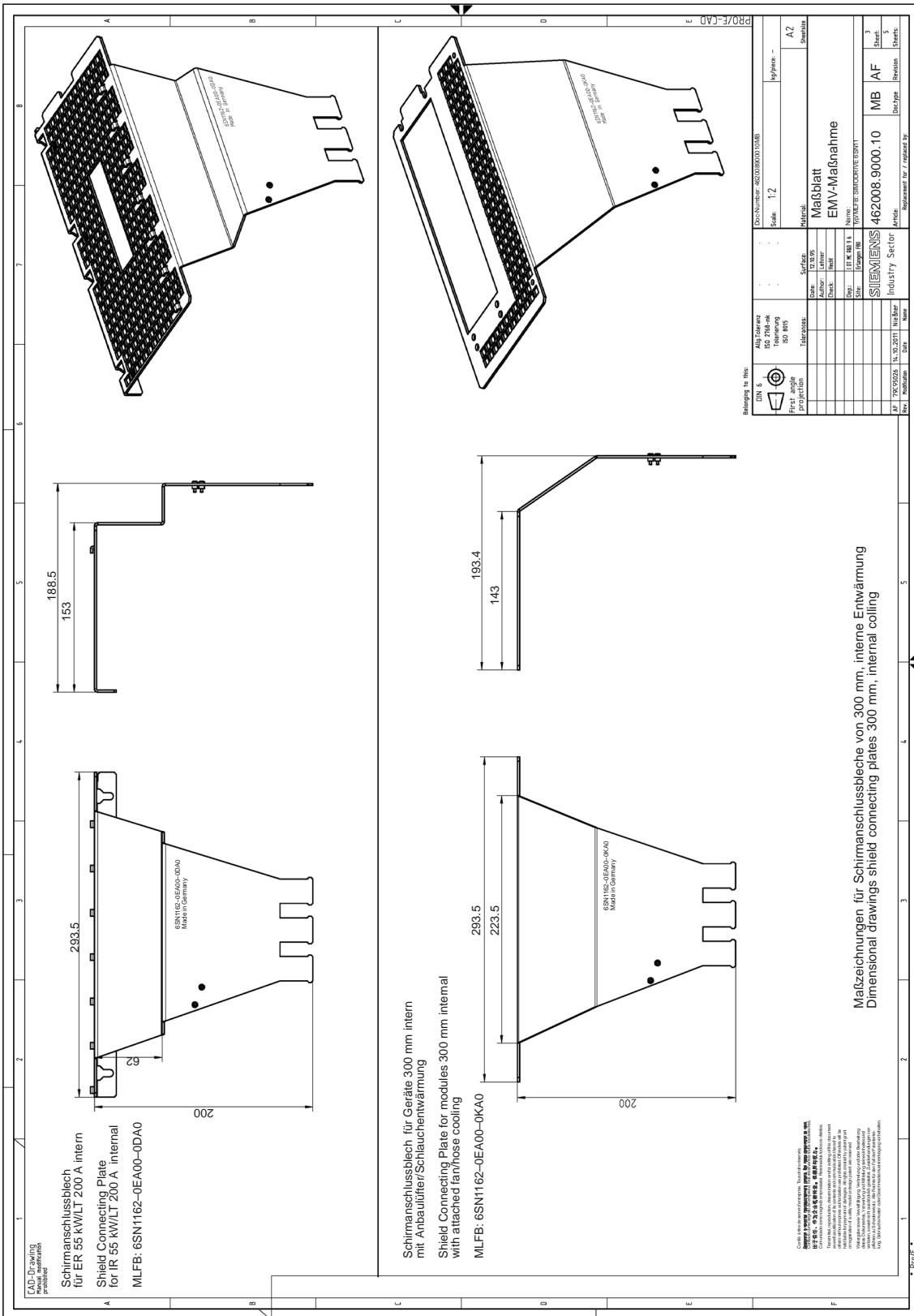

Fig. 12-30 EMC measures, Sheet 3 (shield connection plate, 6SN1162-0EA00-0DA0; -0KA0)

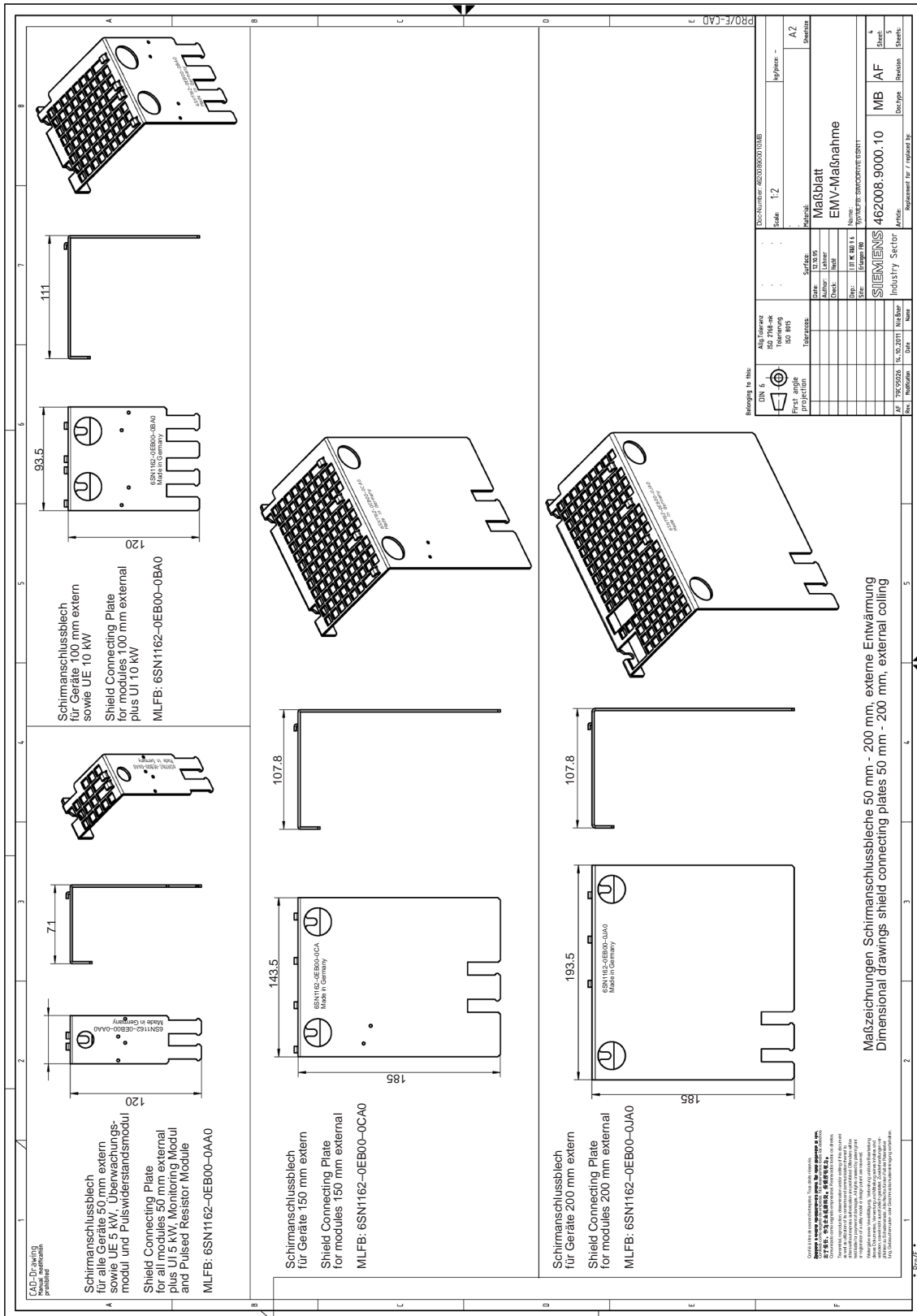

Fig. 12-31 EMC measures, Sheet 4 (shield connection plate, 6SN1162-0EB00-0AA0; -0BA0; -0CA0; -0JA0)



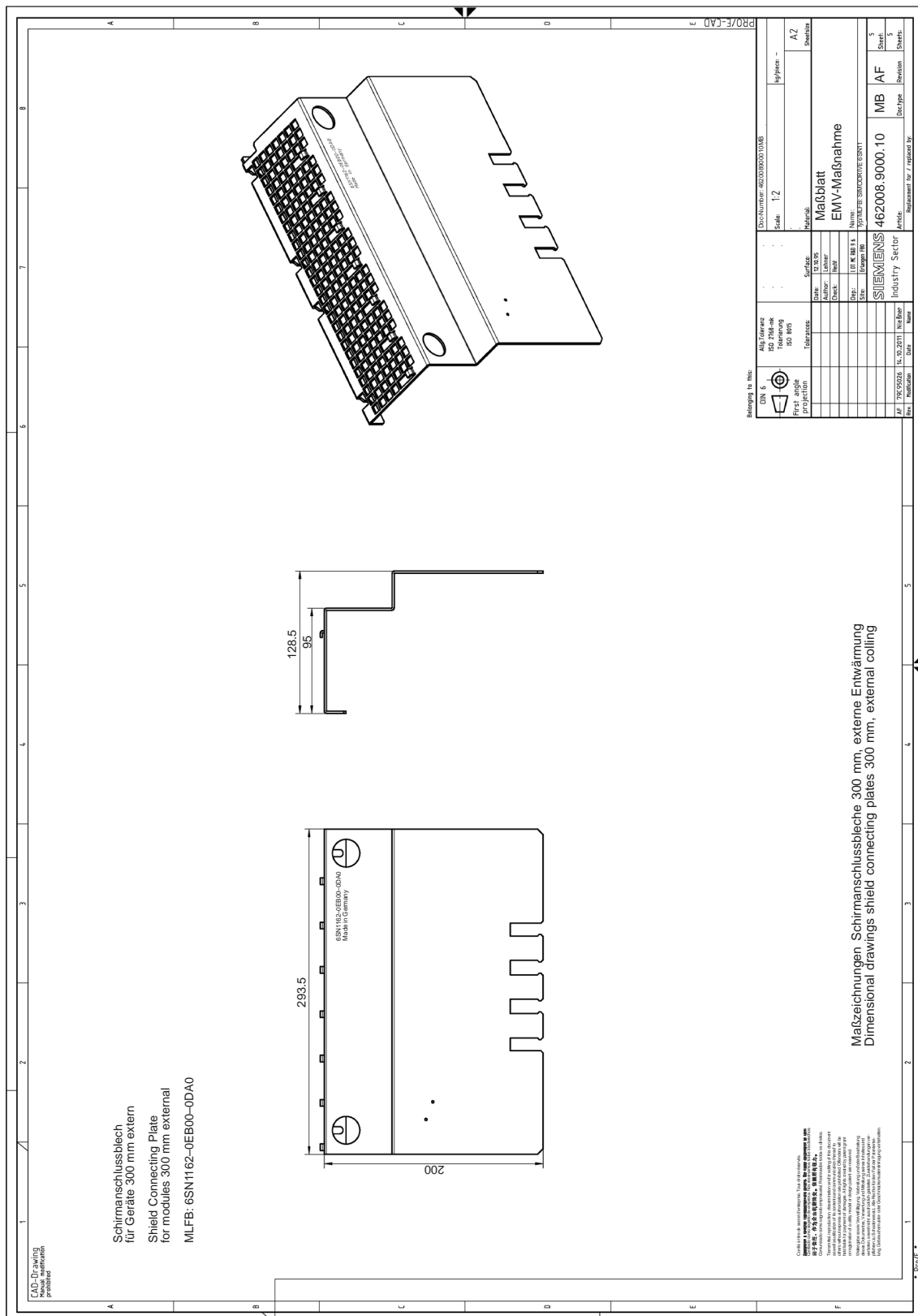

Fig. 12-32 EMC measures, Sheet 5 (shield connection plate, 6SN1162-0EB0-0DA0)

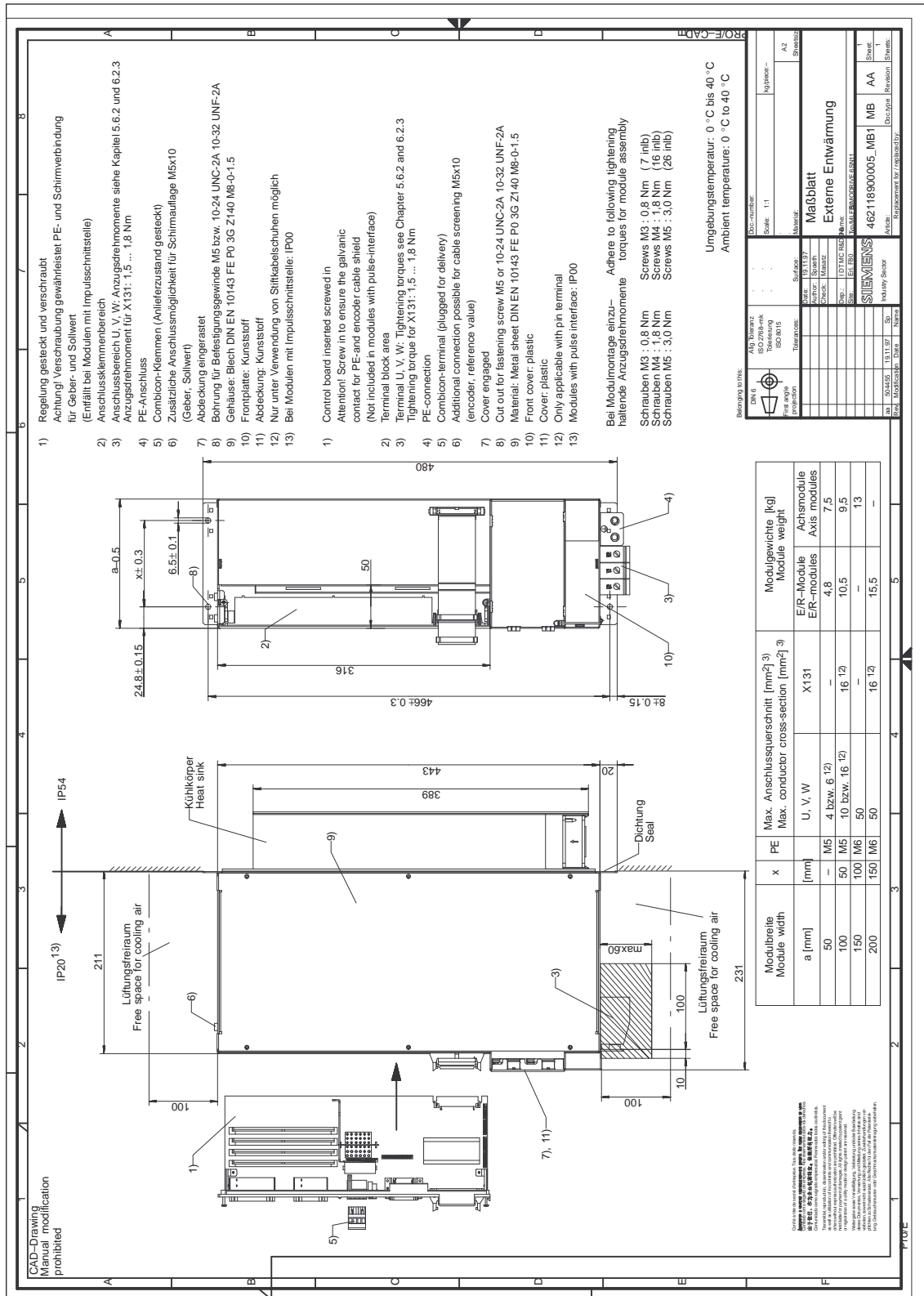

Fig. 12-33 External cooling, module width 50...200 mm

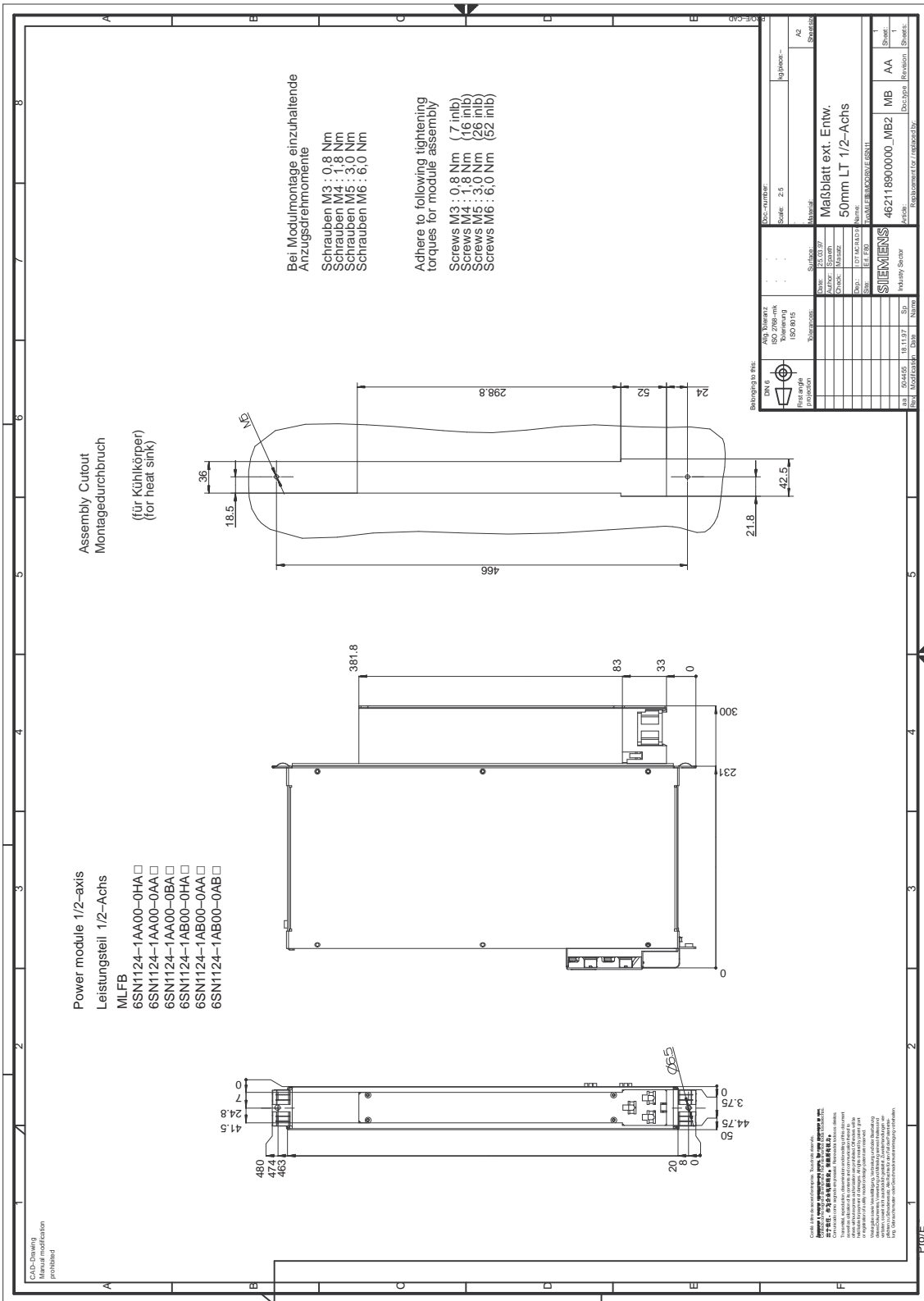

Fig. 12-34 External cooling, 50 mm 1–2 axes; PM module 6SN1124-1AA00-0xAx, 6SN1124-1AB00-0xA1

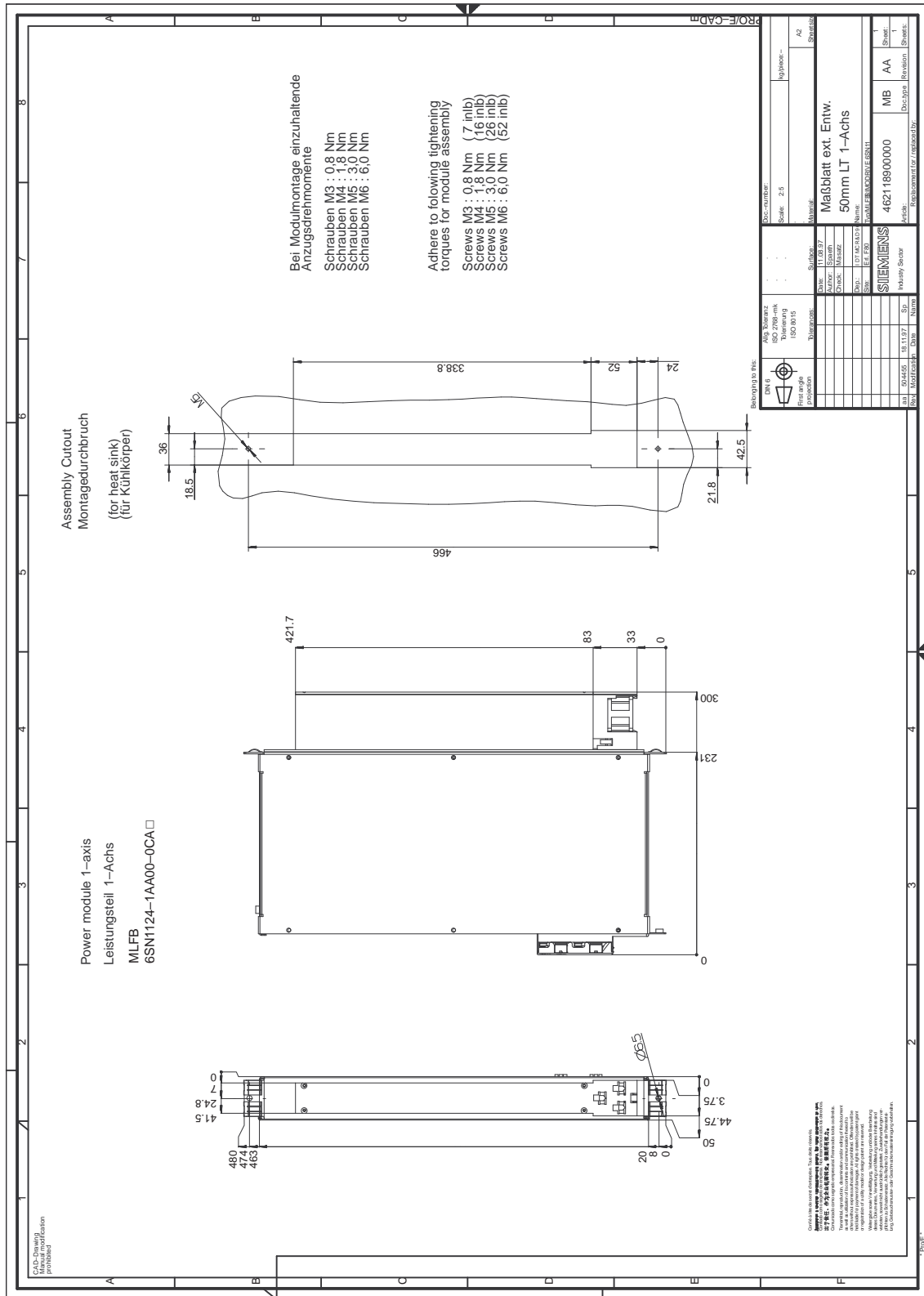

Fig. 12-35 External cooling, 50 mm 1 axis; PM module 6SN1124-1AA00-0CA1

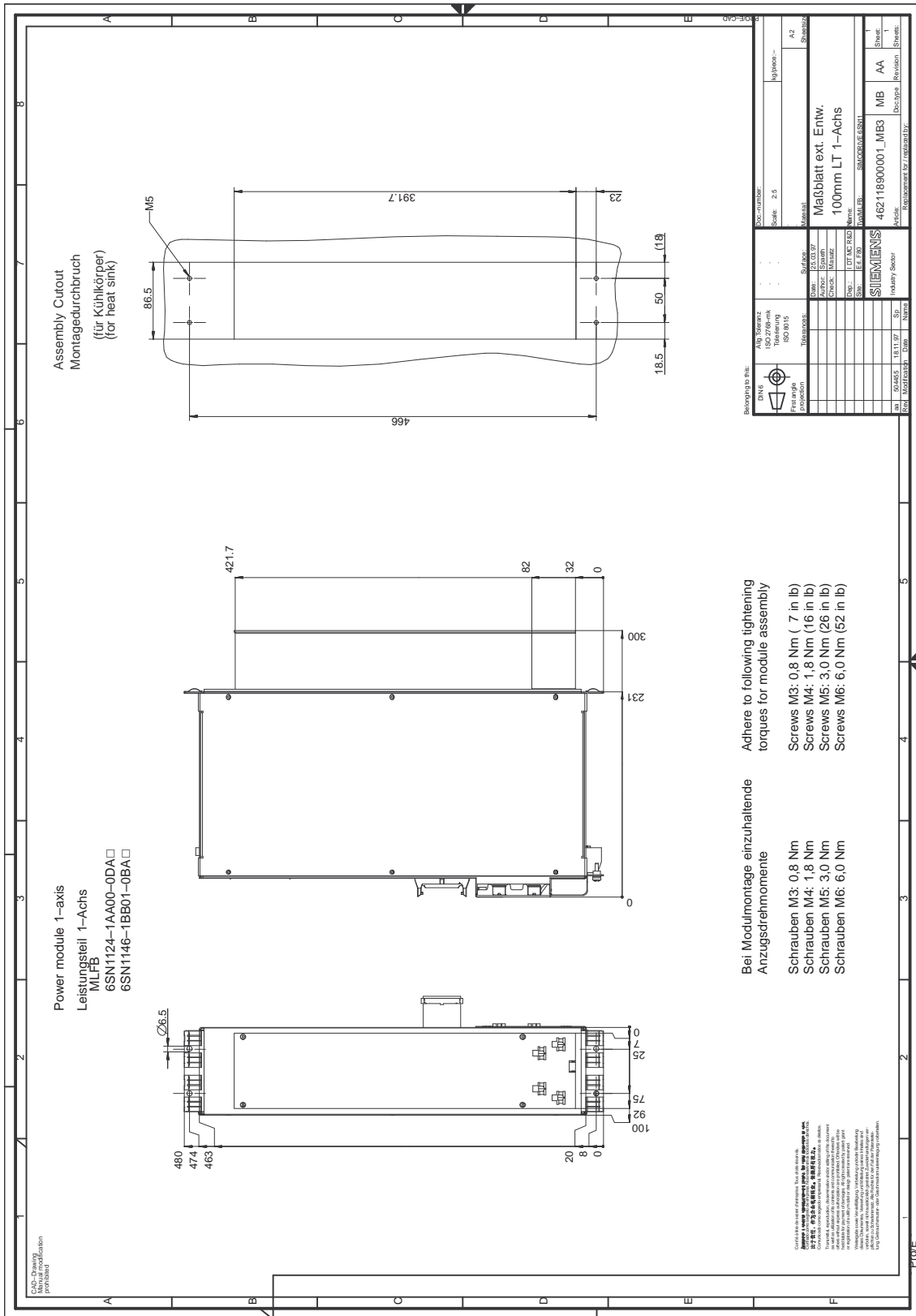

Fig. 12-36 External cooling, 100 mm 1 axis; PM module 6SN1124-1AA00-0DA2 and I/R module 6SN1146-1BB01-0BA2



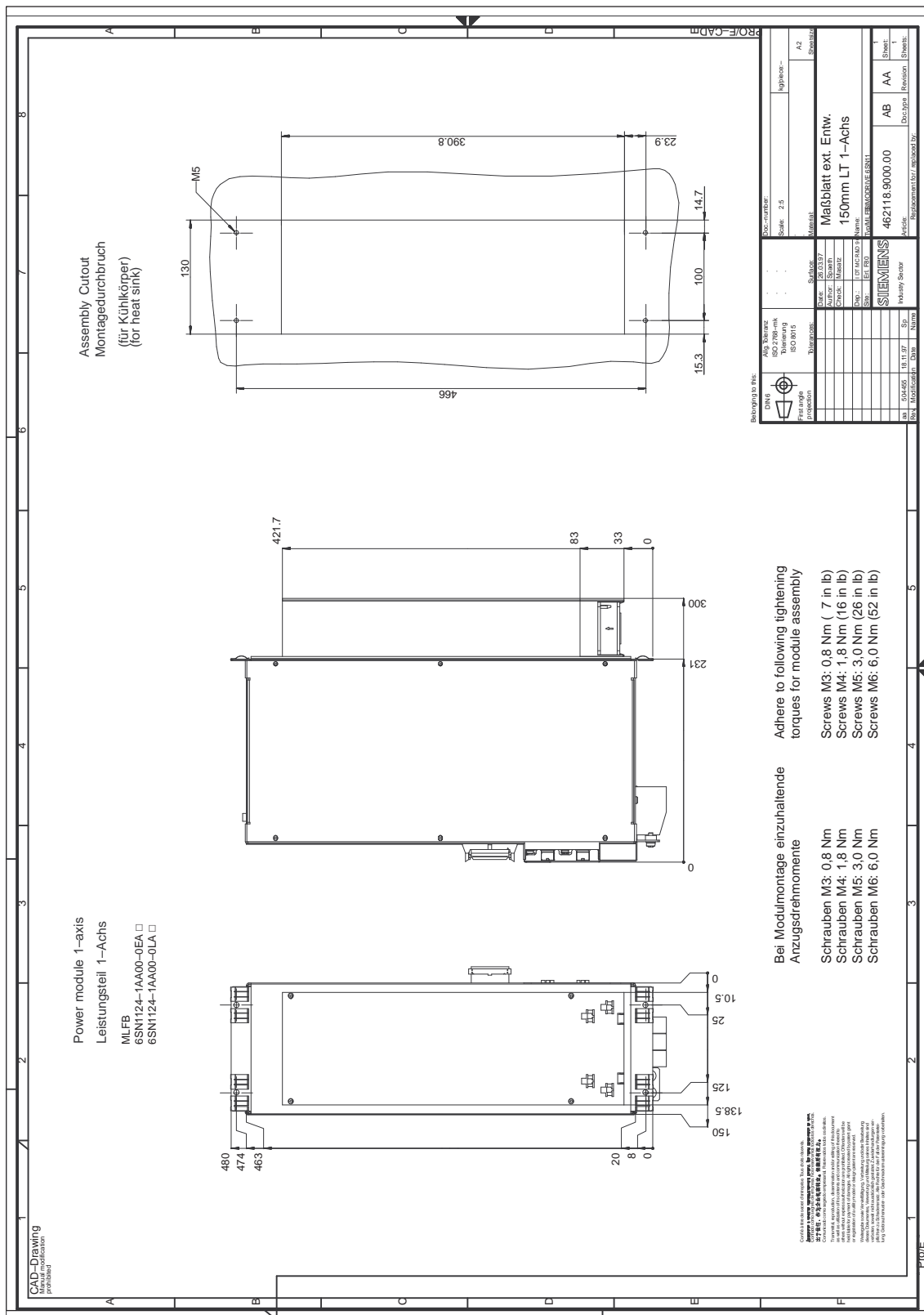

Fig. 12-38 External cooling, 150 mm 1 axis; PM module 6SN1124-1AA00-0EA2/-0LA3

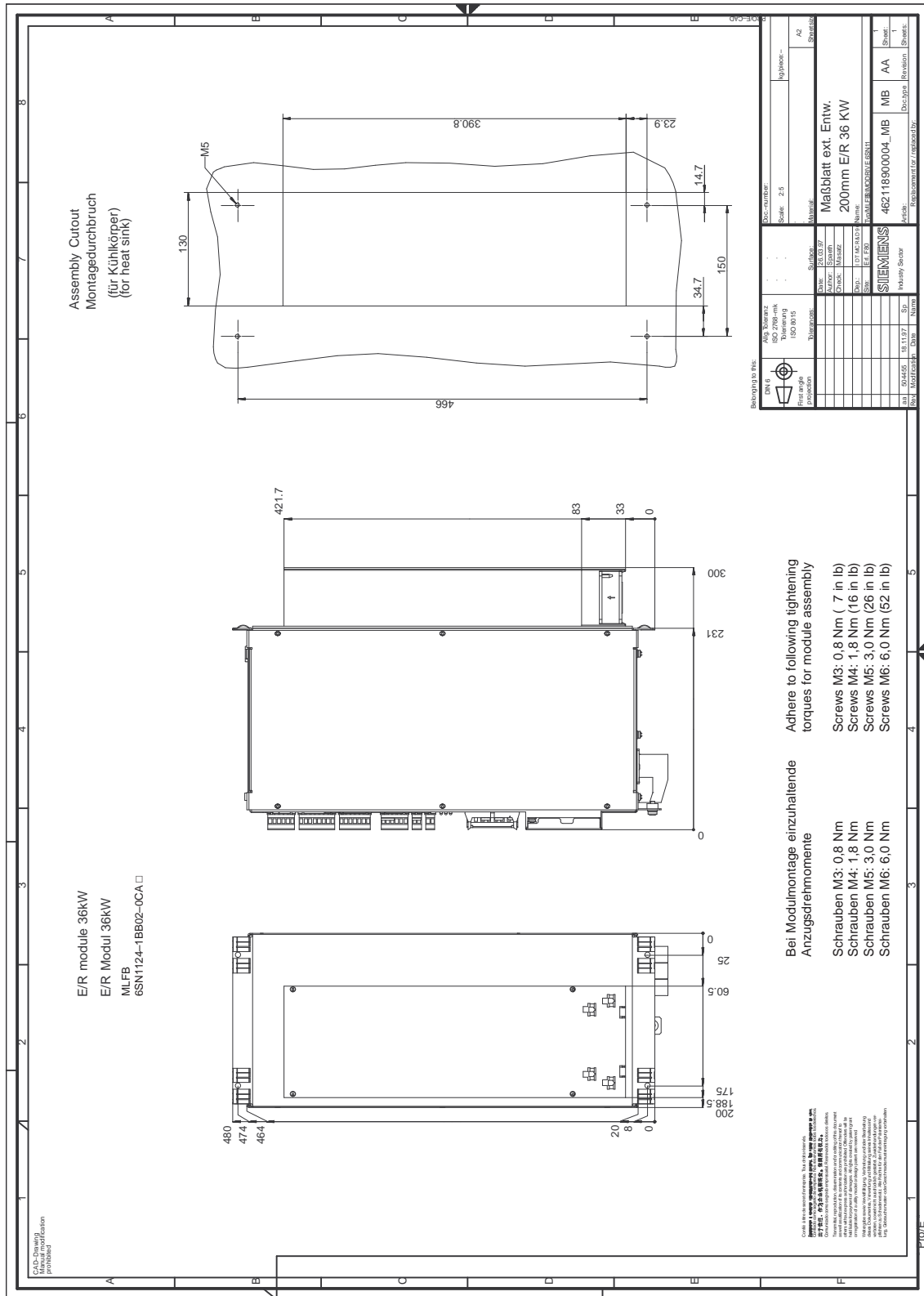

Fig. 12-39 External cooling, 200 mm; I/R module 6SN1146-1BB02-0CA2



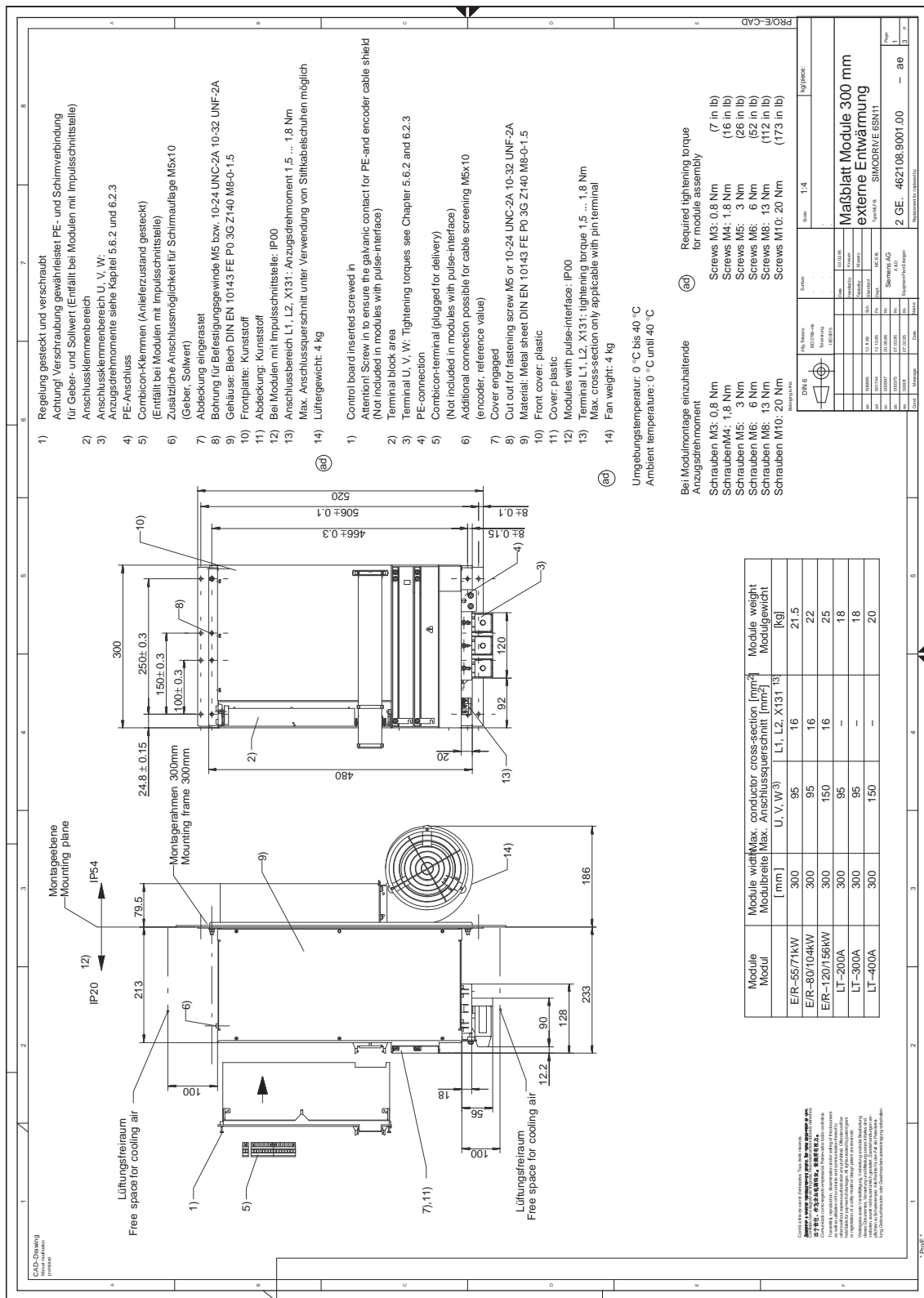

Fig. 12-40 External cooling, 300 mm PM module 6SN1124-1AA0x-0xA1 and I/R module 6SN1146-1BB00-0xA1; Sheet 1

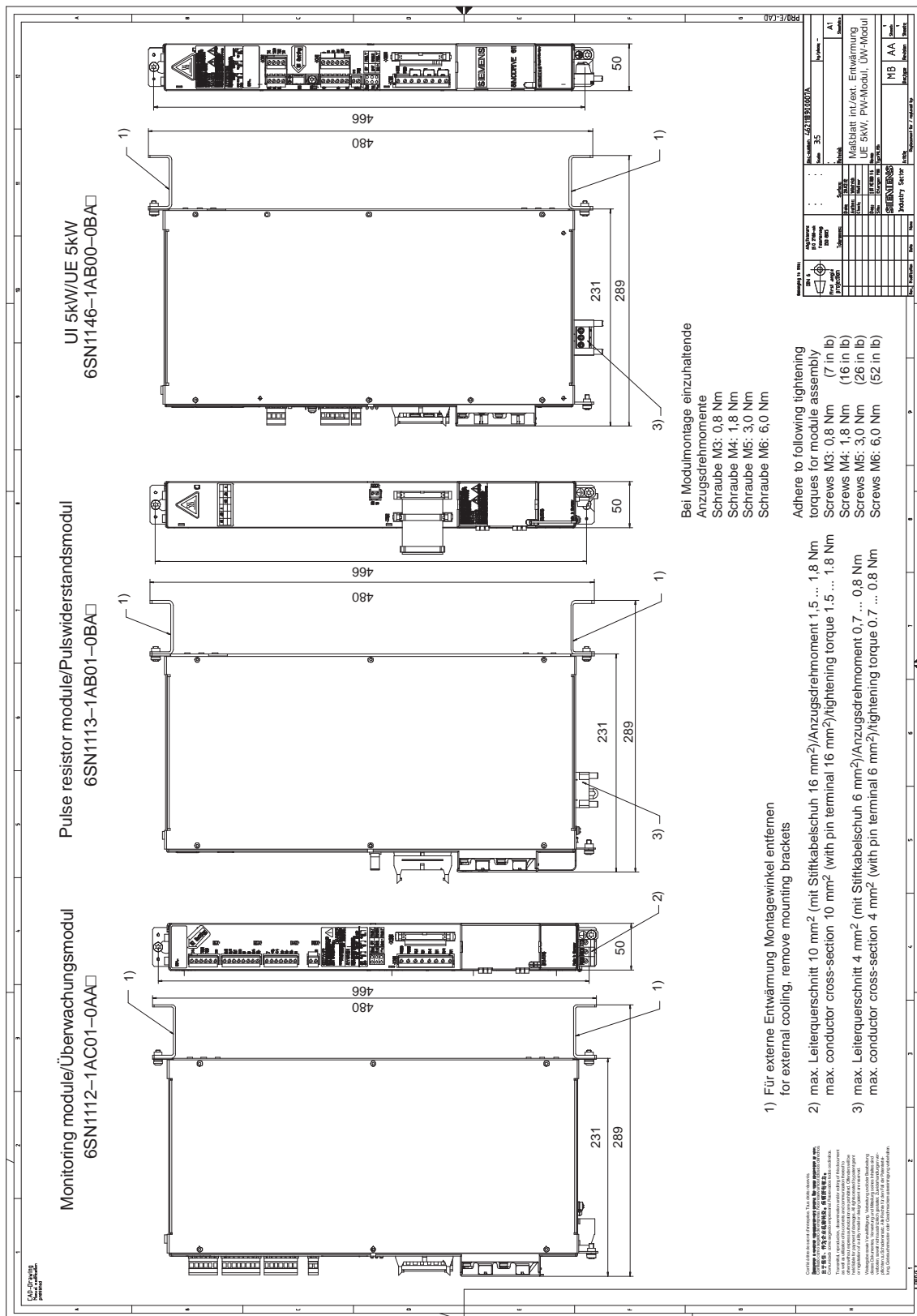

Fig. 12-41 Internal/external cooling, 50 mm UI module (6SN1146-1AB00-0BAx); pulse resistor module (6SN1113-1AB01-0BAx); monitoring module (6SN1112-1AC01-0AAx)

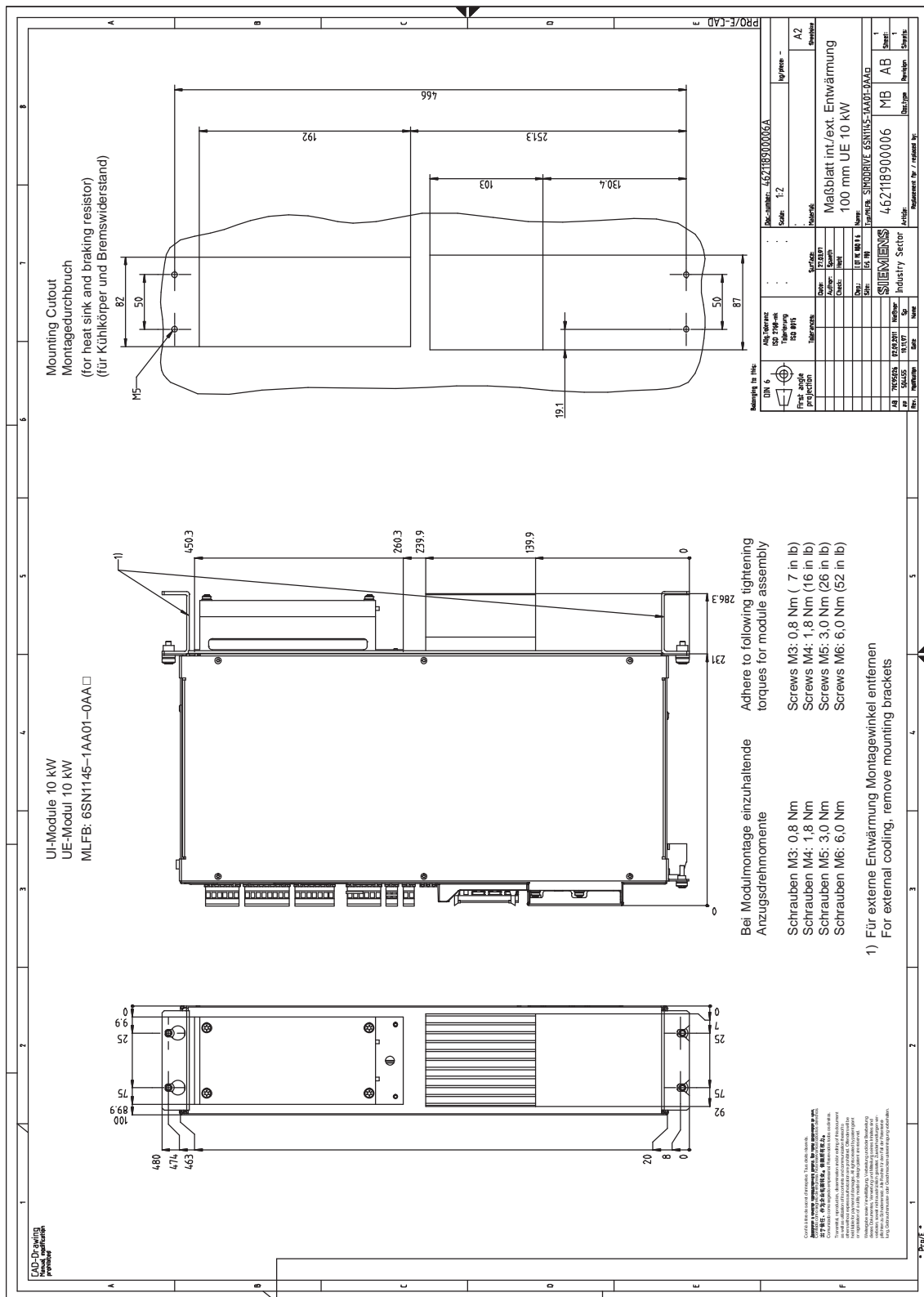

Fig. 12-42 Internal/externa cooling, 100 mm UI module; 6SN1145-1AA01-0AA2

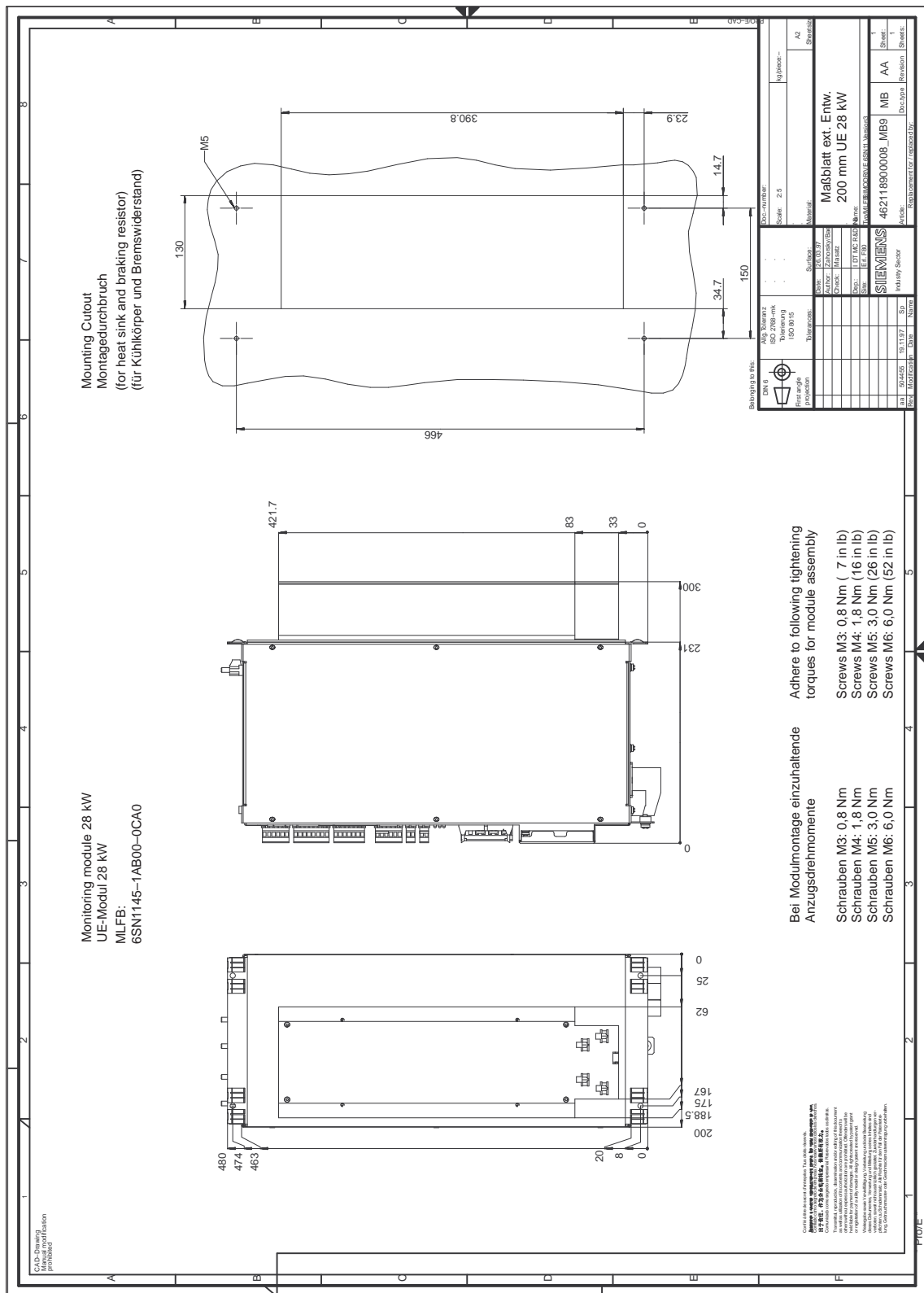

Fig. 12-43 External cooling, 200 mm UI-Modul; 6SN1146-1AB00-0CA0

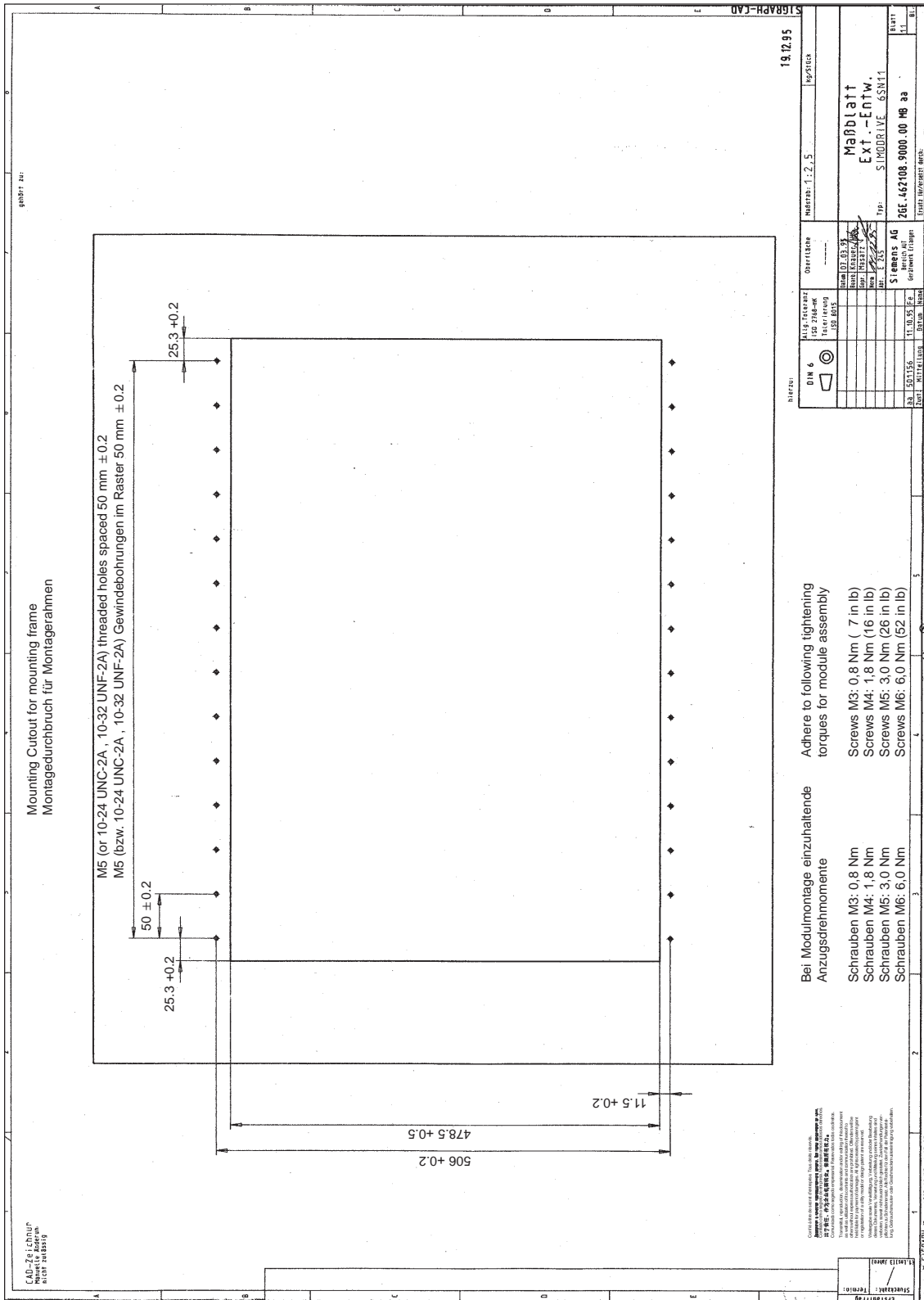

Fig. 12-44 External cooling, installation cutout for installation frames

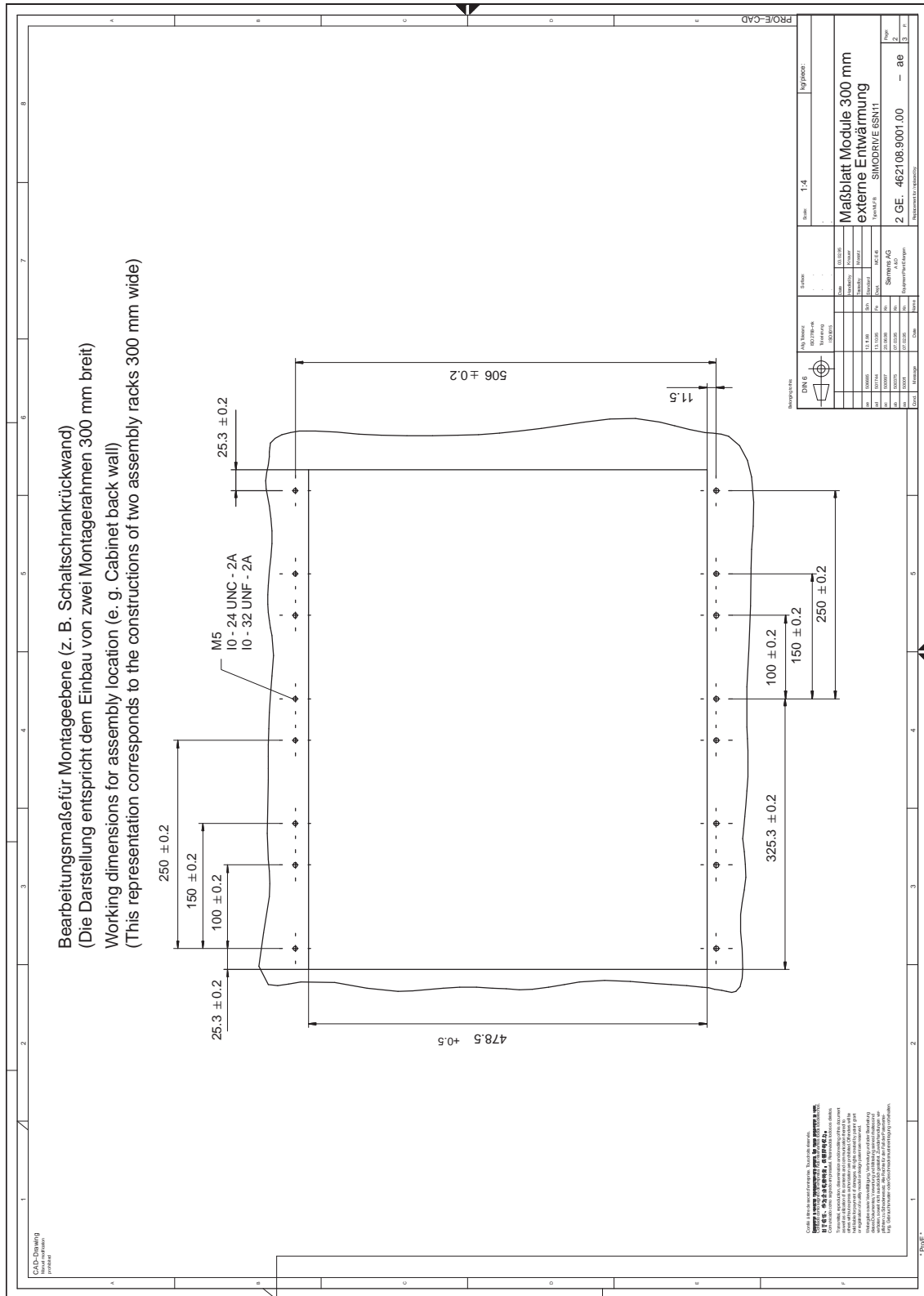

Fig. 12-45 External cooling, module 300 mm mounting plane, PM module 6SN1124-1AA0x-0xA1 and I/R module 6SN1146-1BB00-0xA1

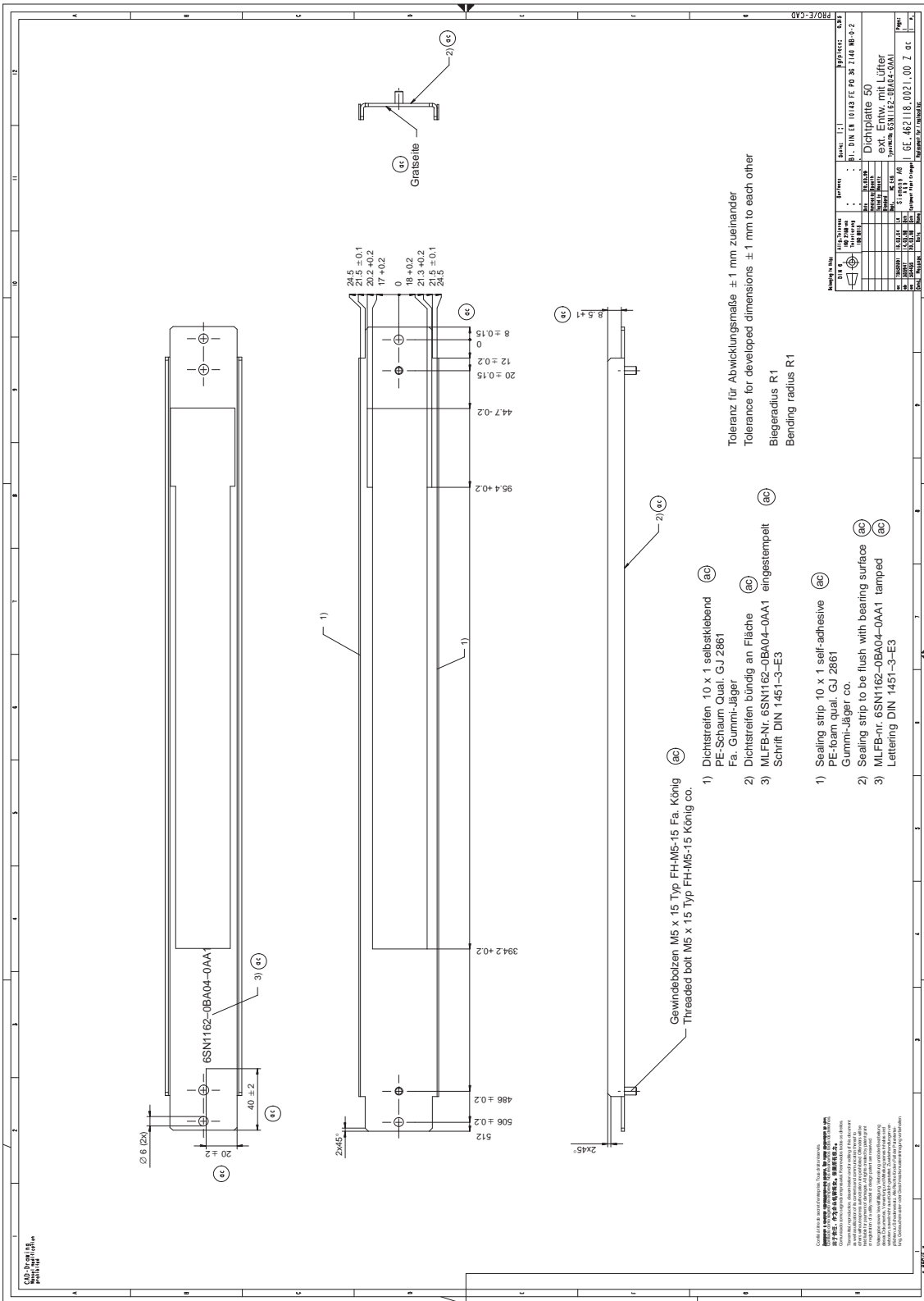

Fig. 12-46 External cooling, mounting frame for cabinet installation, 50 mm module width, 6SN1162-0BA04-0AA1

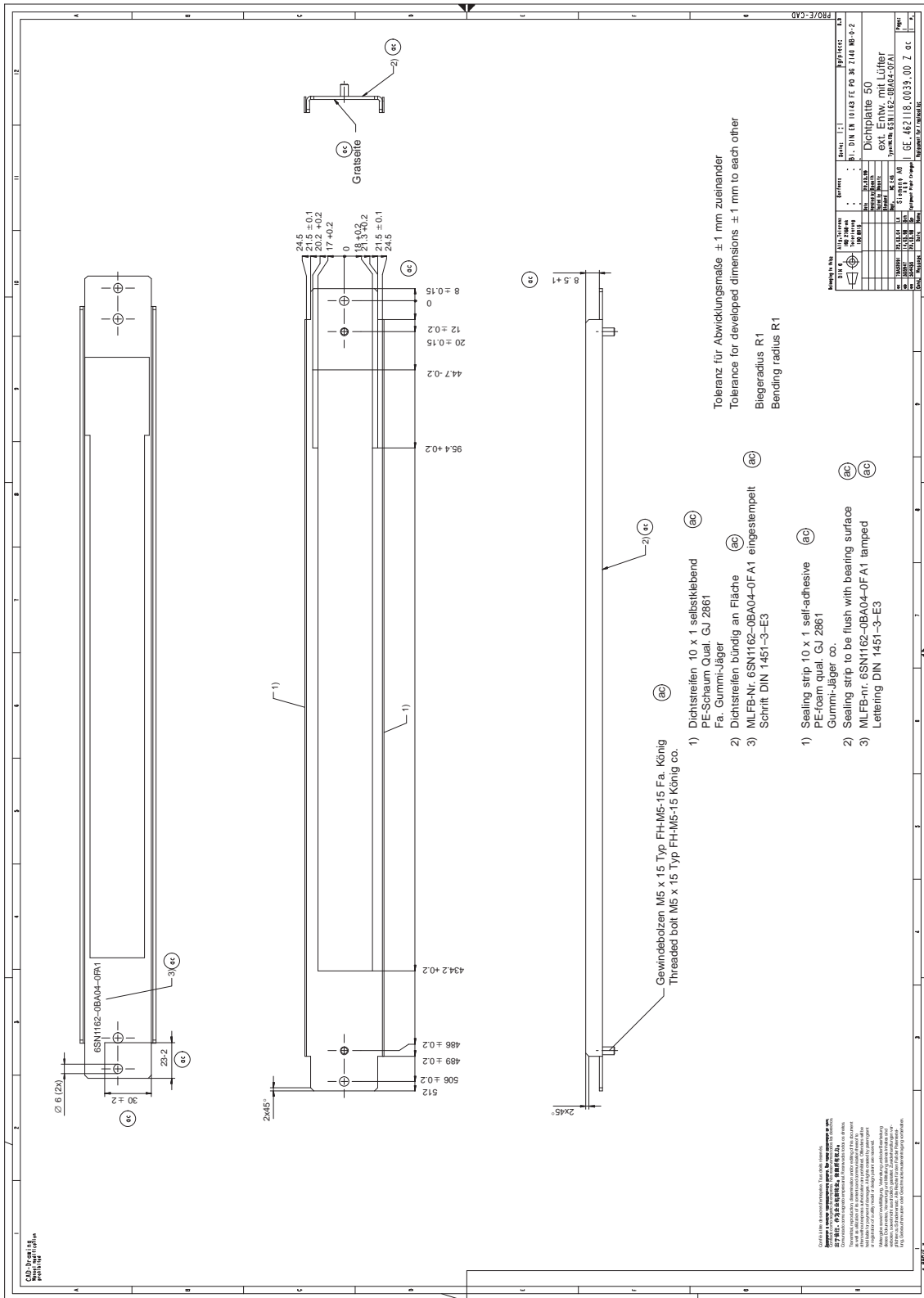

Fig. 12-47 External cooling, mounting frame for cabinet installation, 50 mm module width, 6SN1162-0BA04-0FA1

1 5 8



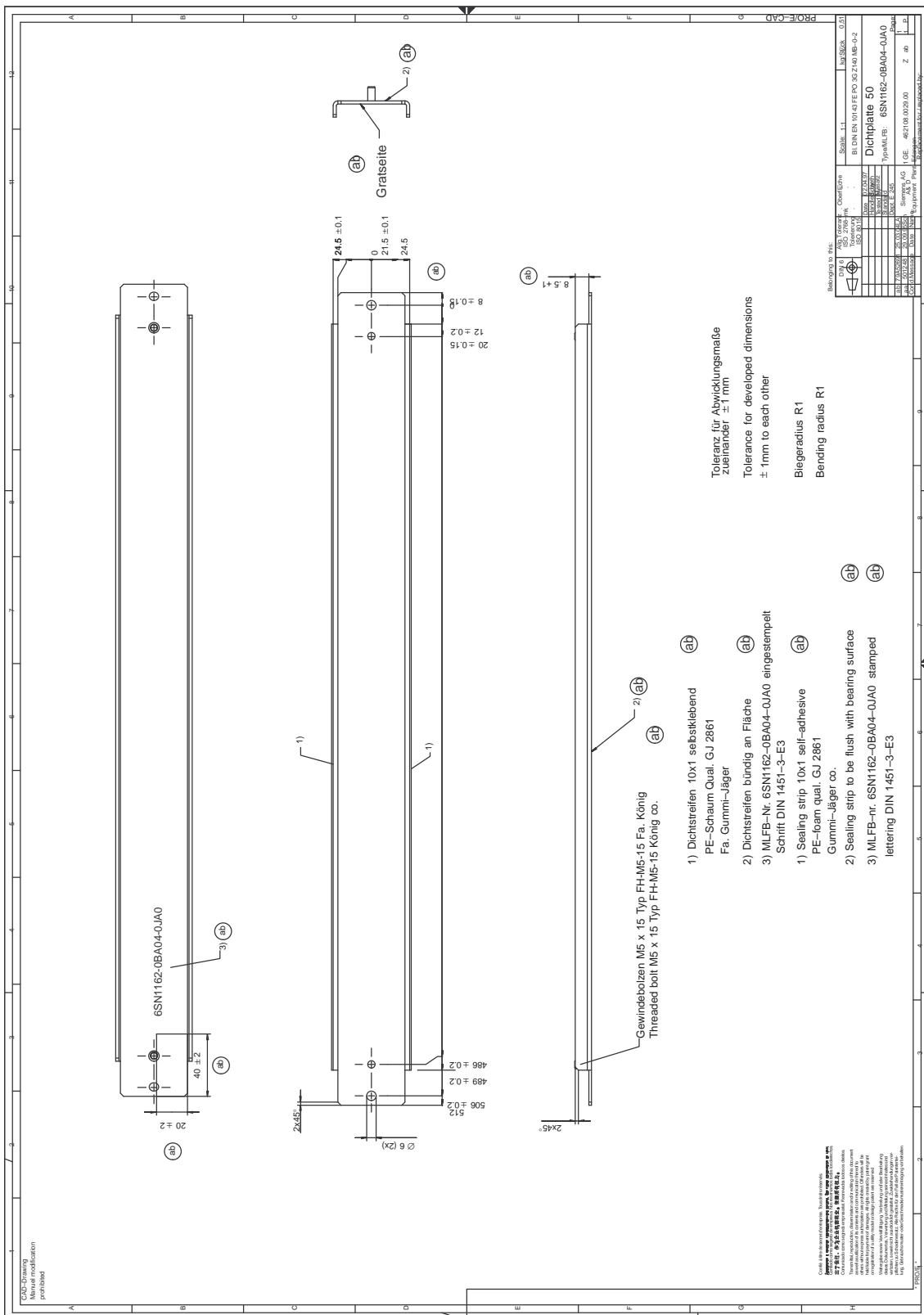

Fig. 12-48 External cooling, mounting frame for cabinet installation, 50 mm module width, 6SN1162-0BA04-0JA0

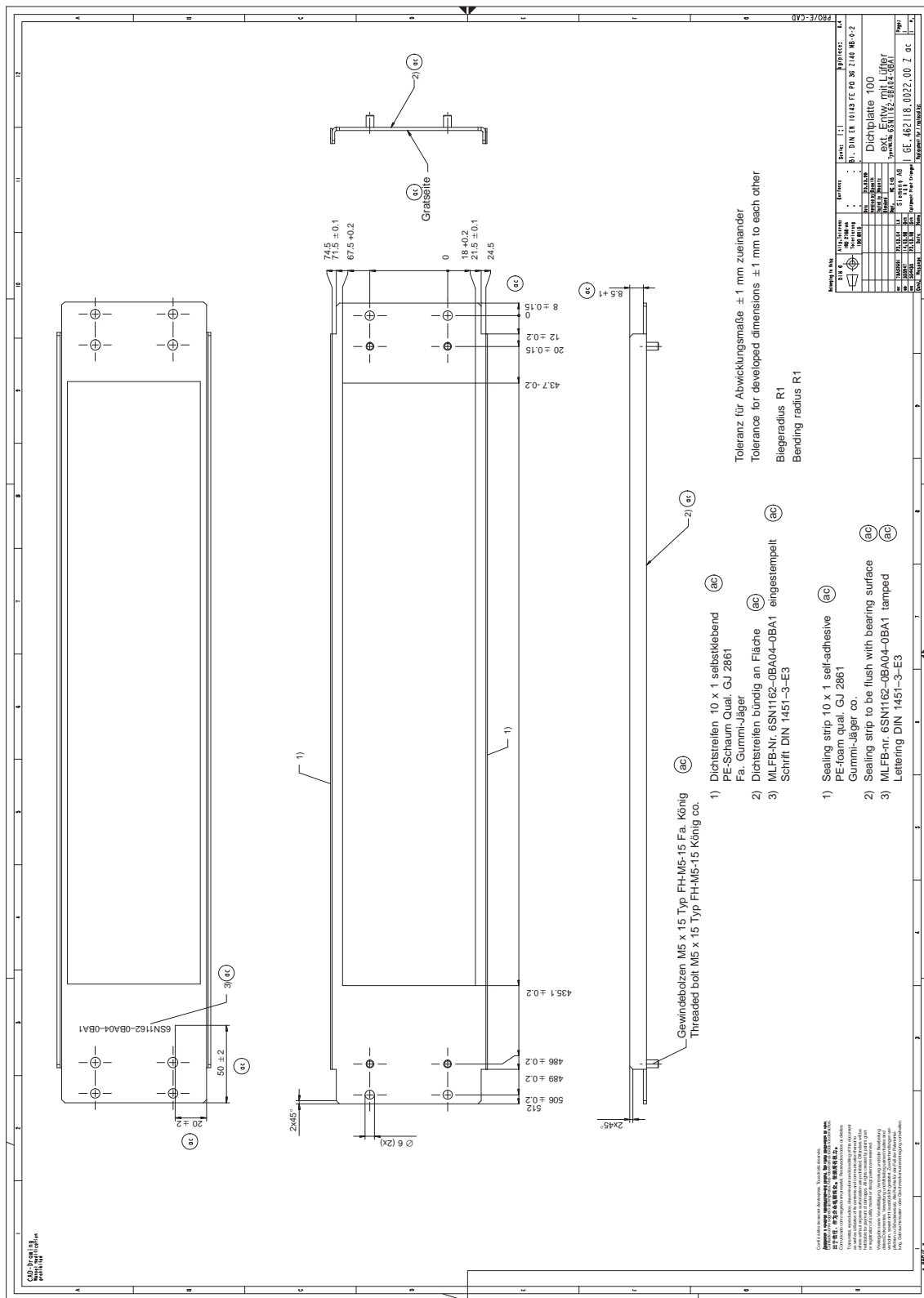

Fig. 12-49 External cooling, mounting frame for cabinet installation, 100 mm module width, 6SN1162-0BA04-0BA1

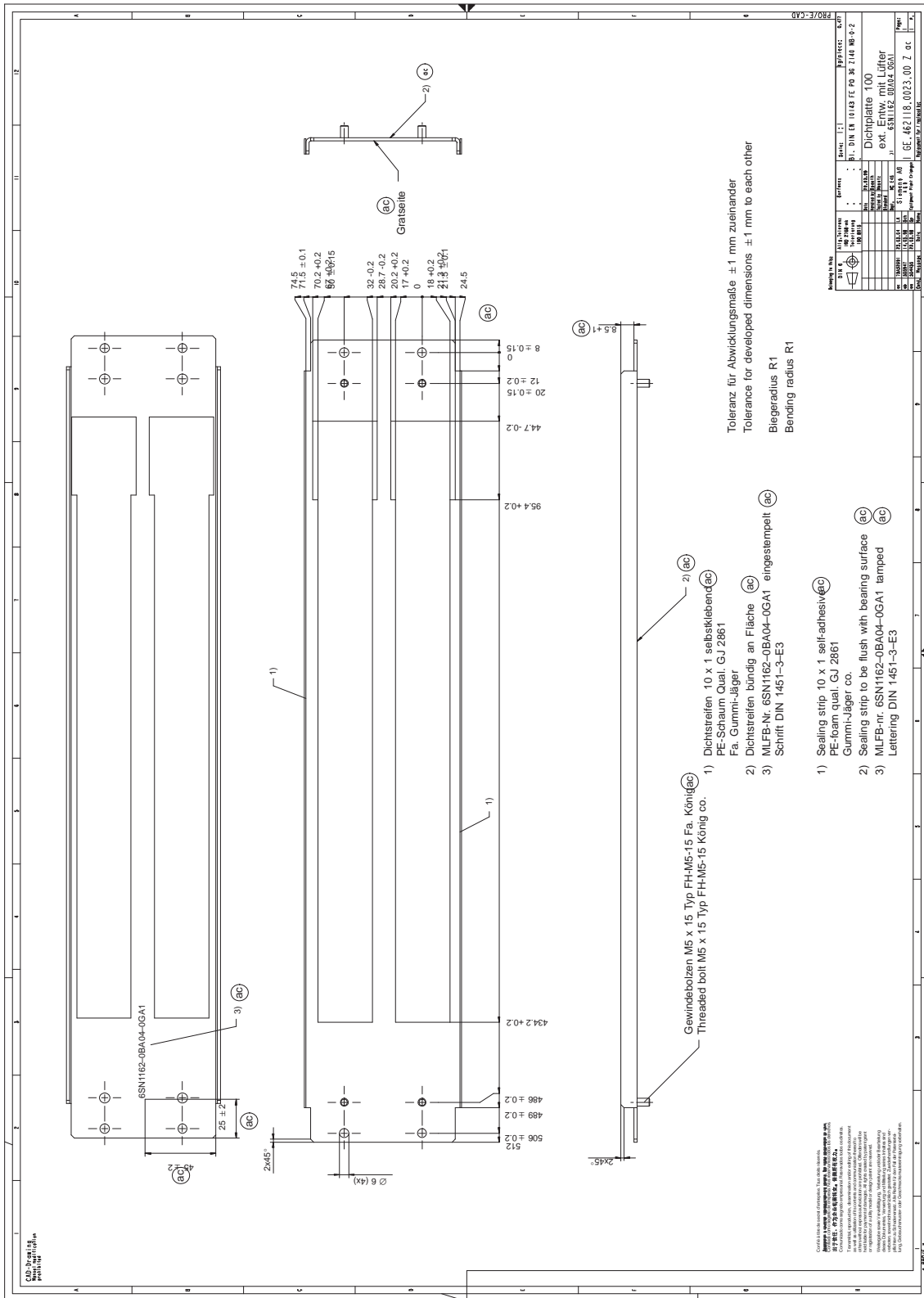

Fig. 12-50 External cooling, mounting frame for cabinet installation, 100 mm module width, 6SN1162-0BA04-0GA1

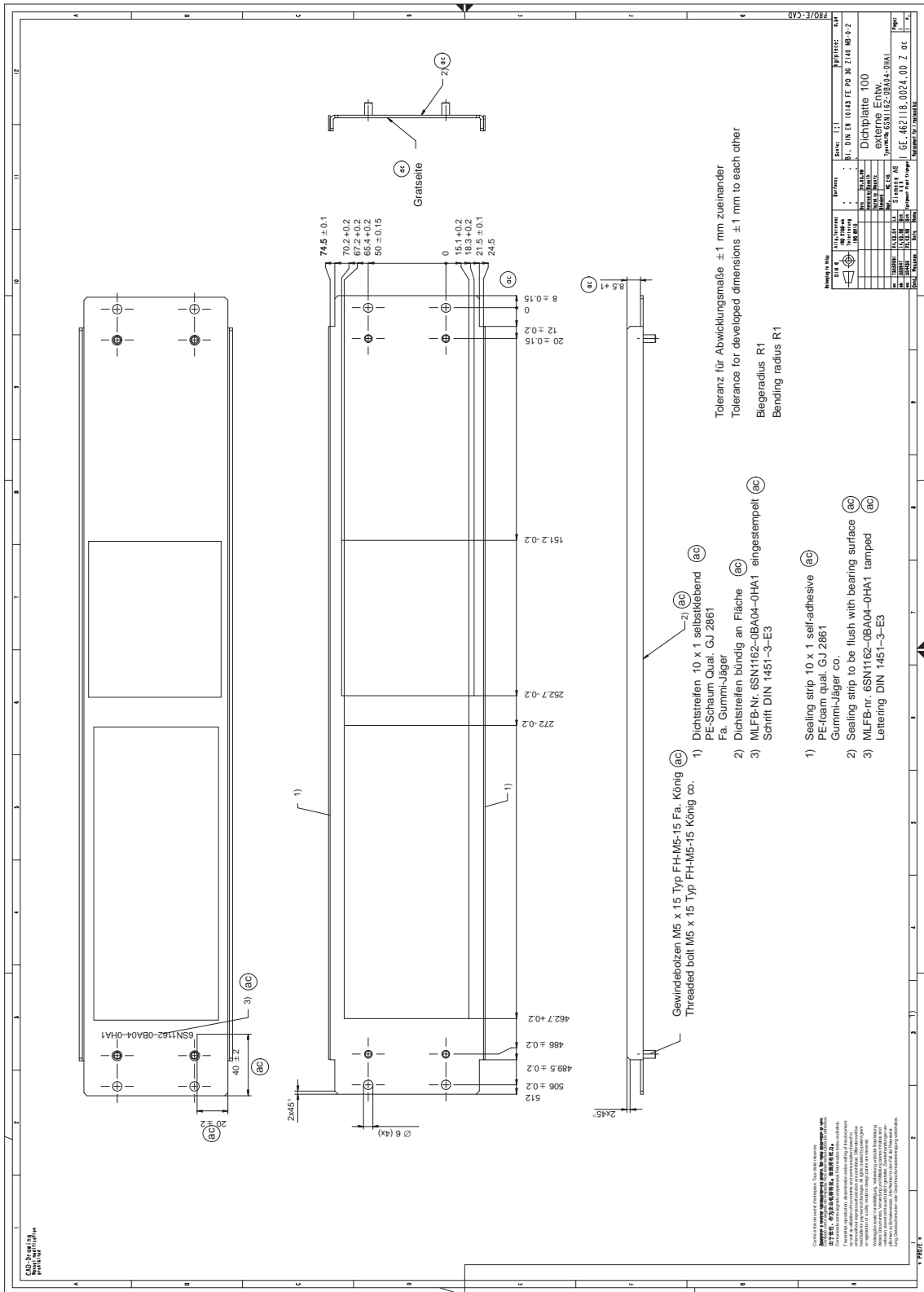

Fig. 12-51 External cooling, mounting frame for cabinet installation module width 100 mm, 6SN1162-0BA04-0HA1

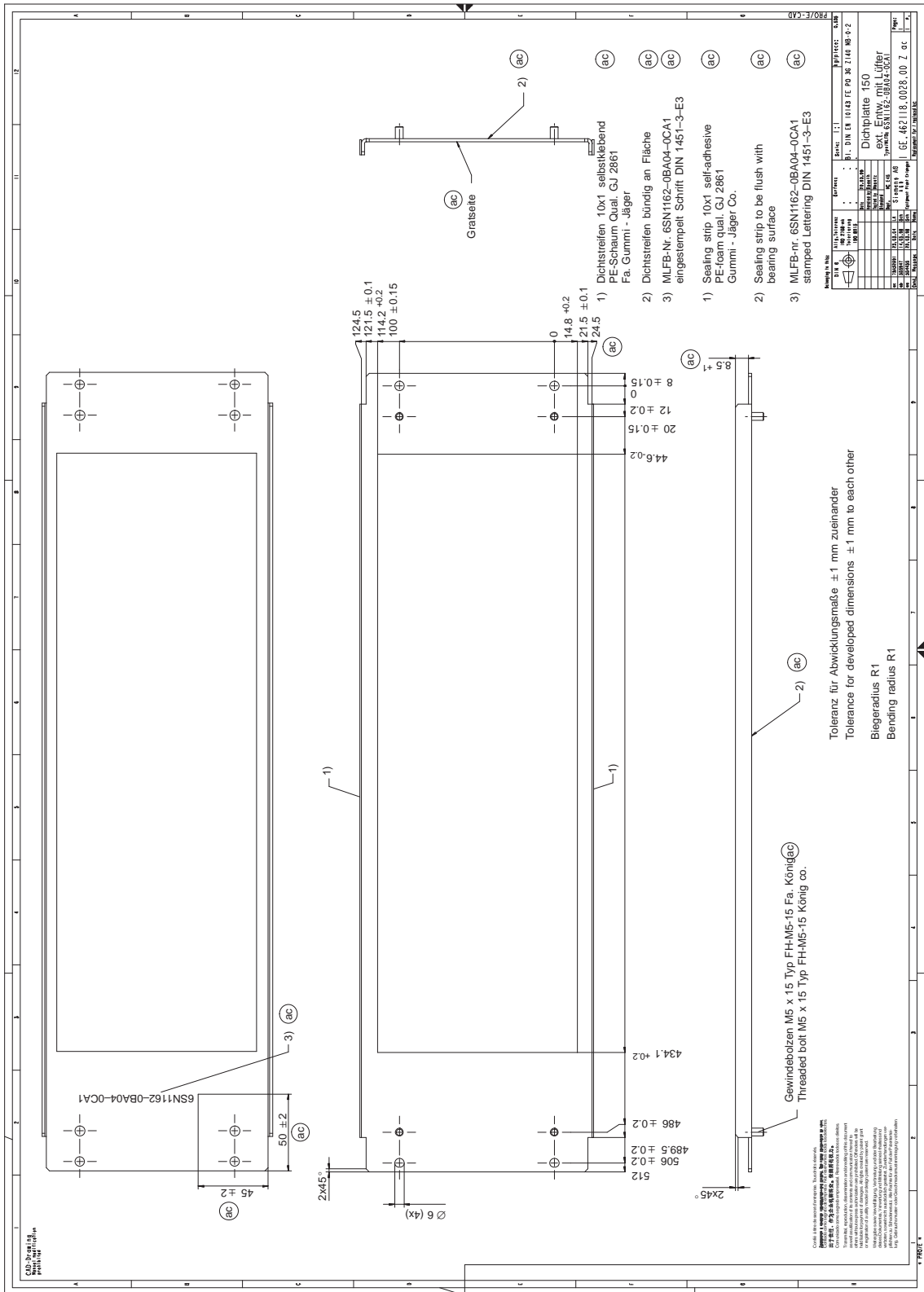

Fig. 12-52 External cooling, mounting frame for cabinet installation, 150 mm module width, 6SN1162-0BA04-0CA1



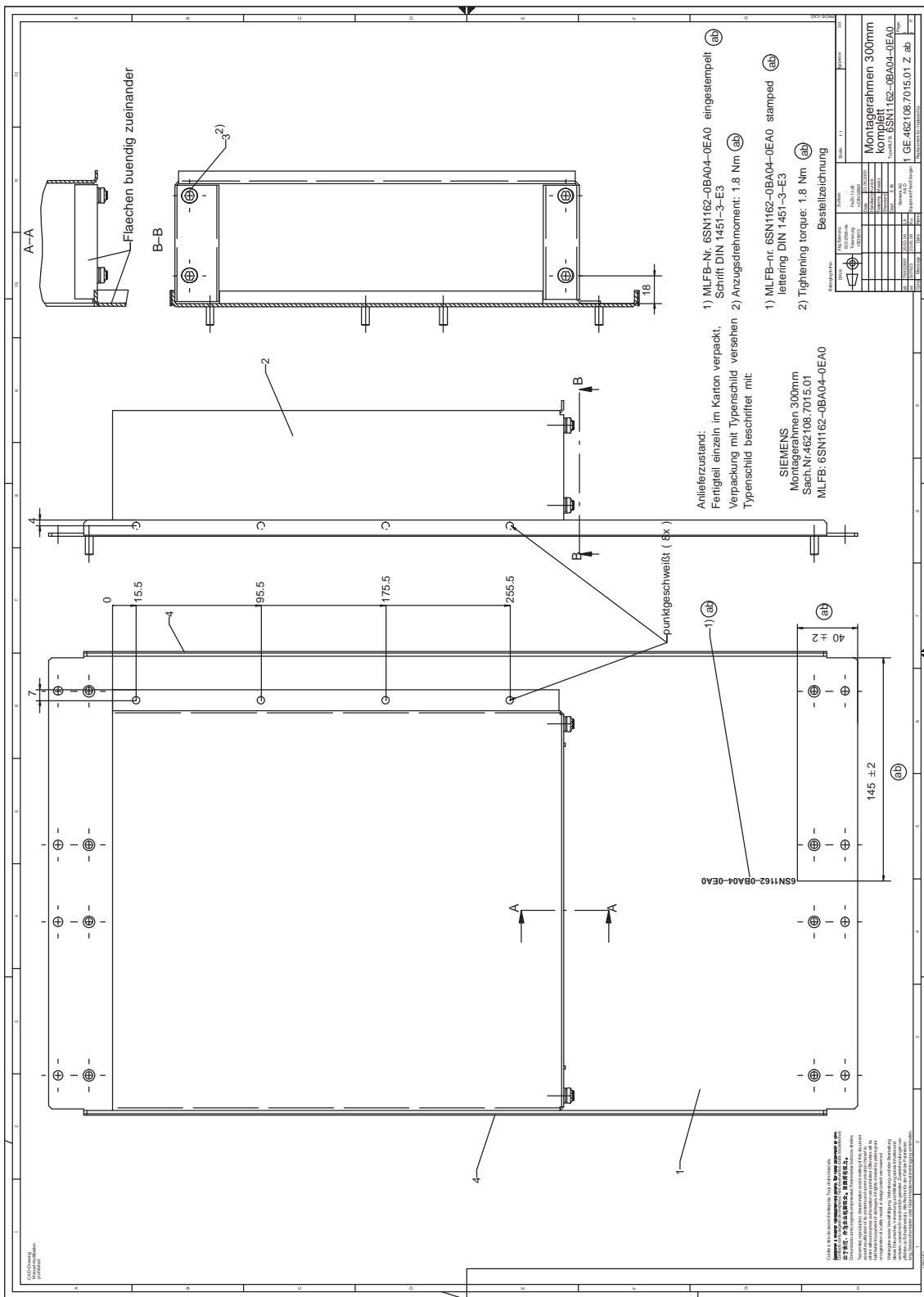

Fig. 12-54 External cooling, mounting frame for cabinet installation, 300 mm module width, 6SN1162-0BA04-0EA0

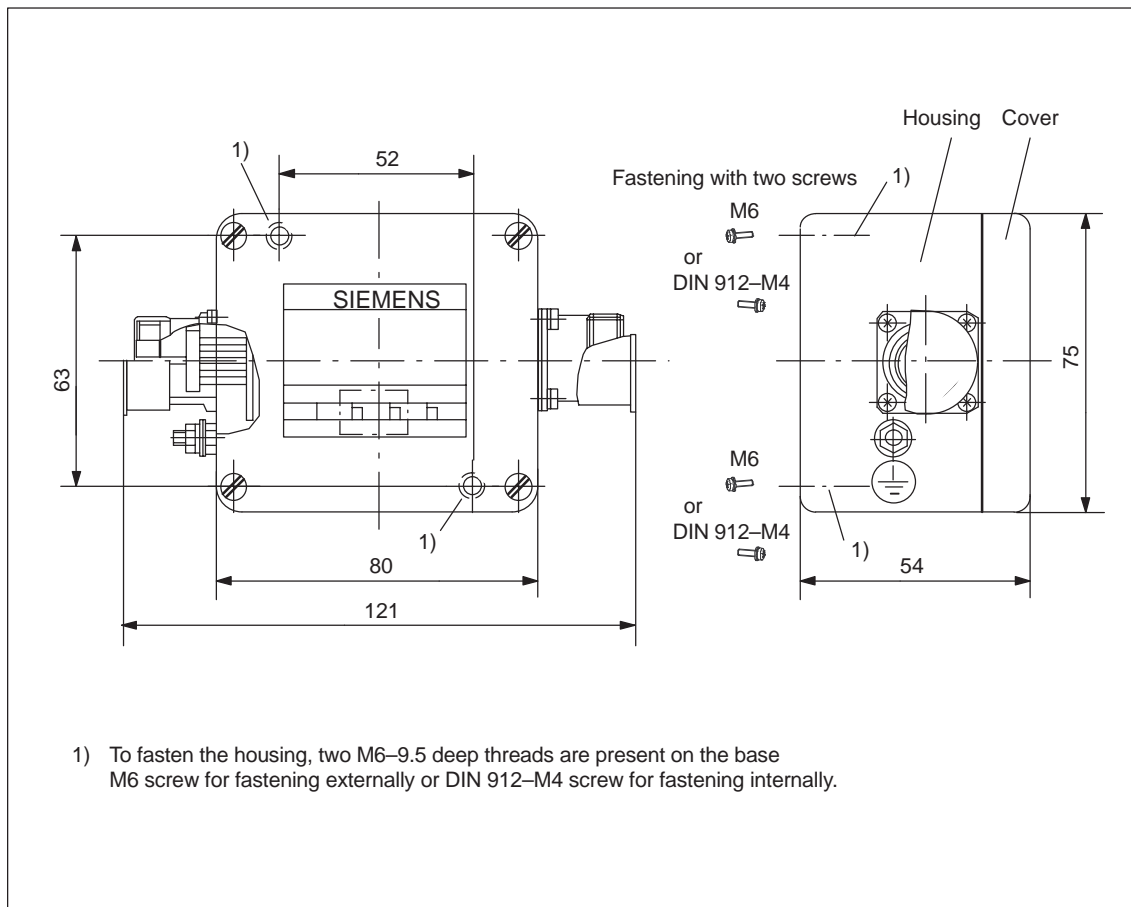

Fig. 12-55 Signal amplifier electronics SVE, 6SN1115–0AA12–0AA0



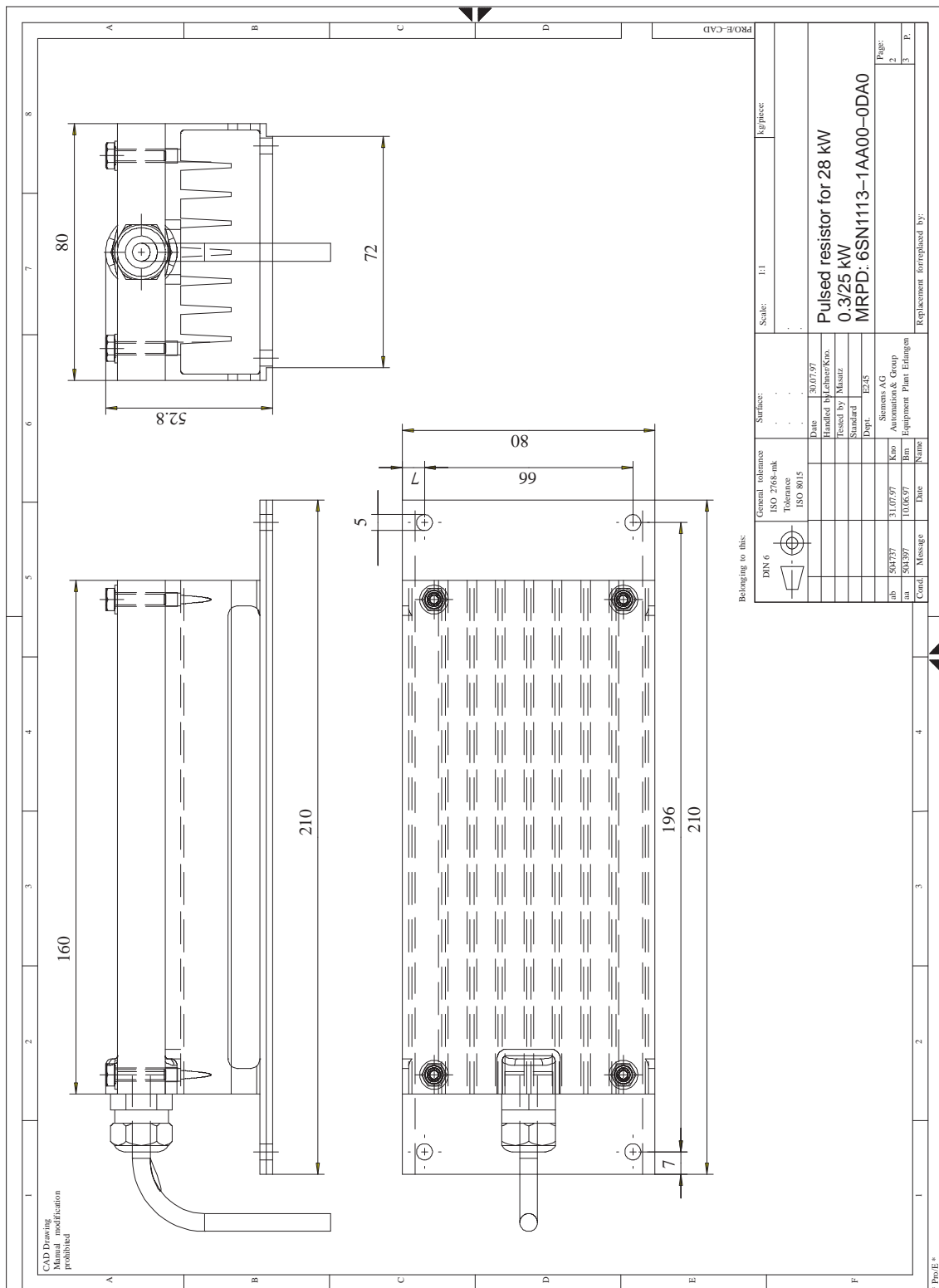

Fig. 12-56 External pulsed resistor for 28kW for UI module, SN1113-1AA00-0DA0

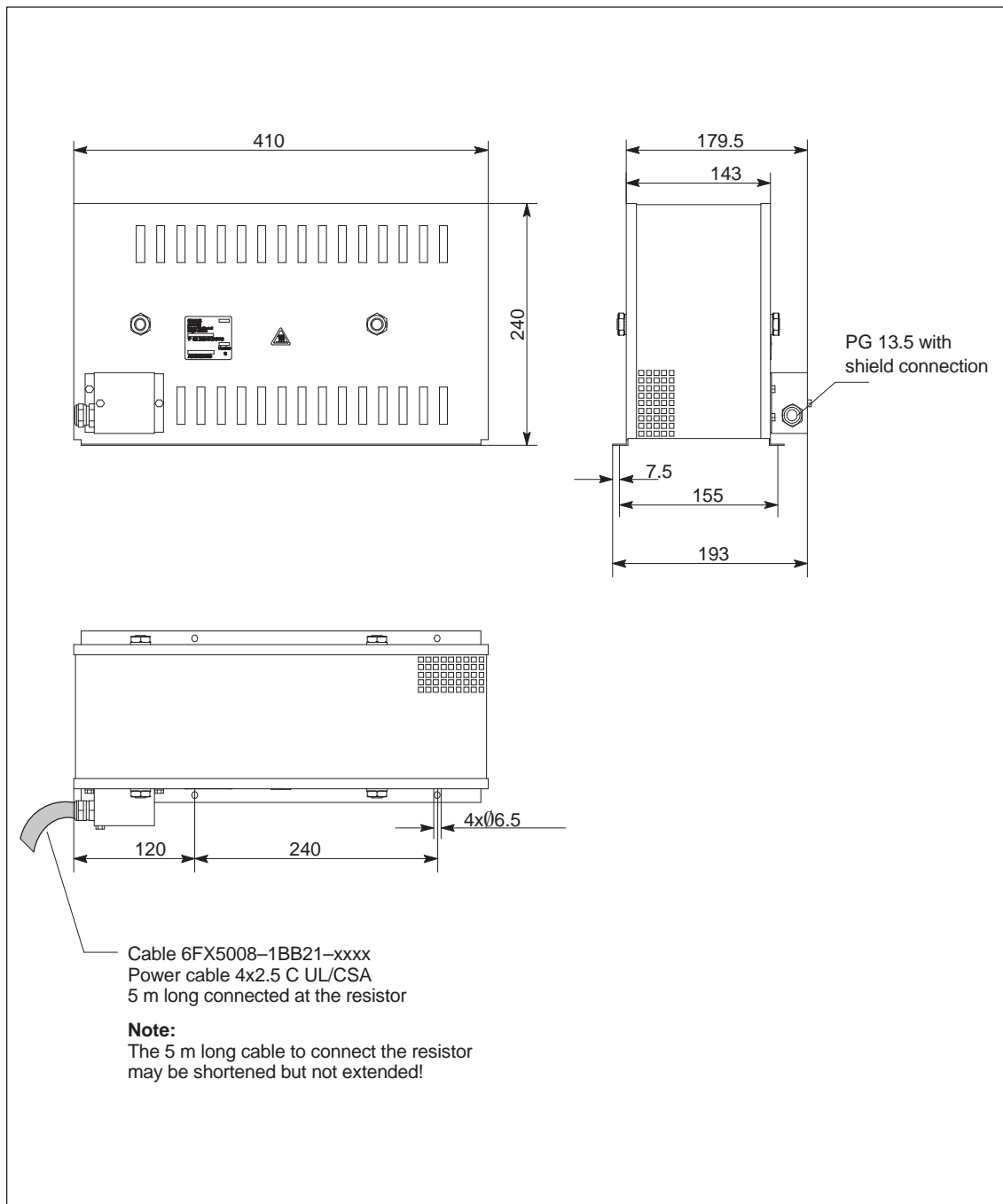

Fig. 12-57 External pulsed resistor Plus, 6SL3100-1BE22-5AA0

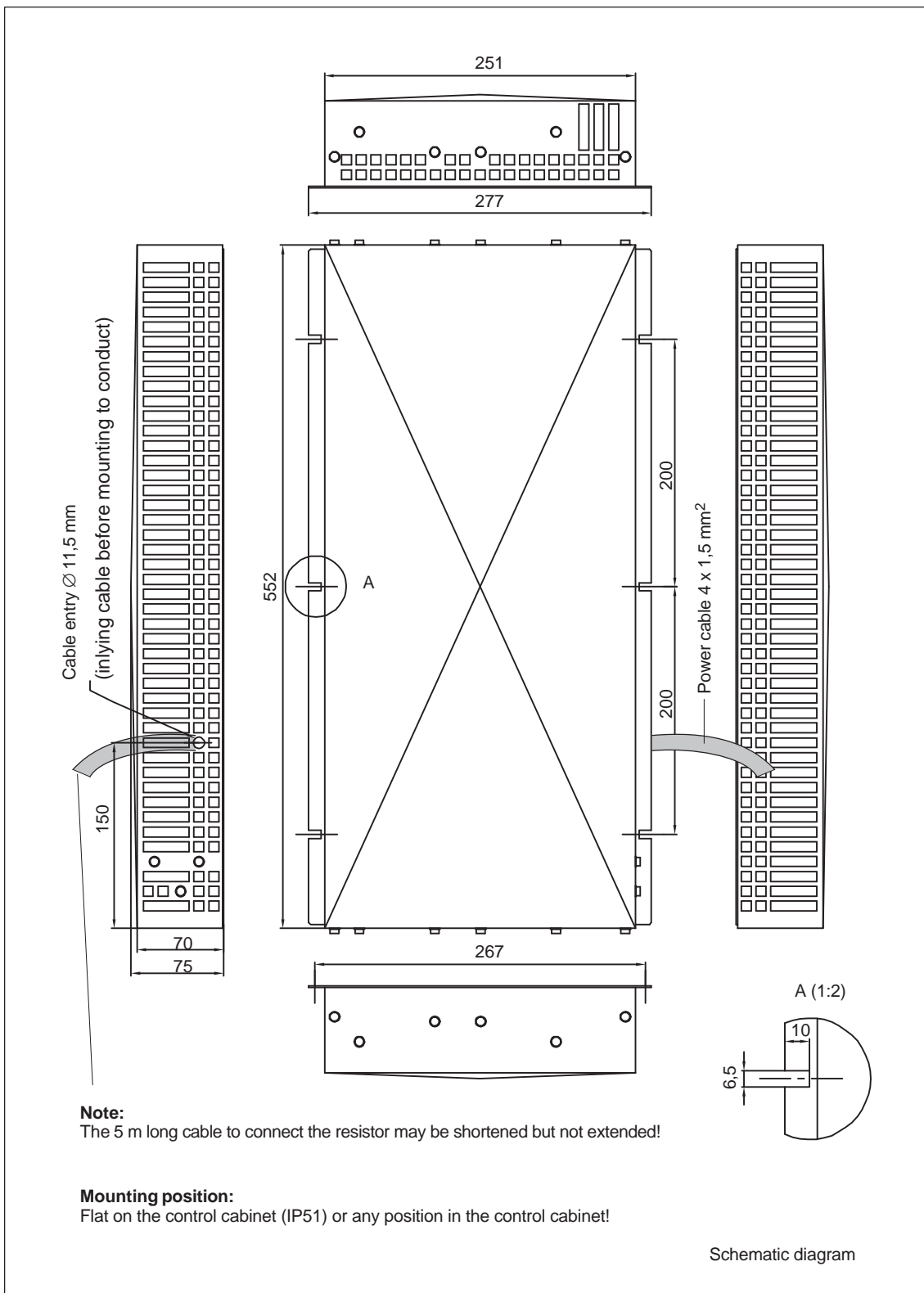

Fig. 12-58 Damping resistor for 3-phase HFD line/commutating reactors, 6SL3100-1BE21-3AA0

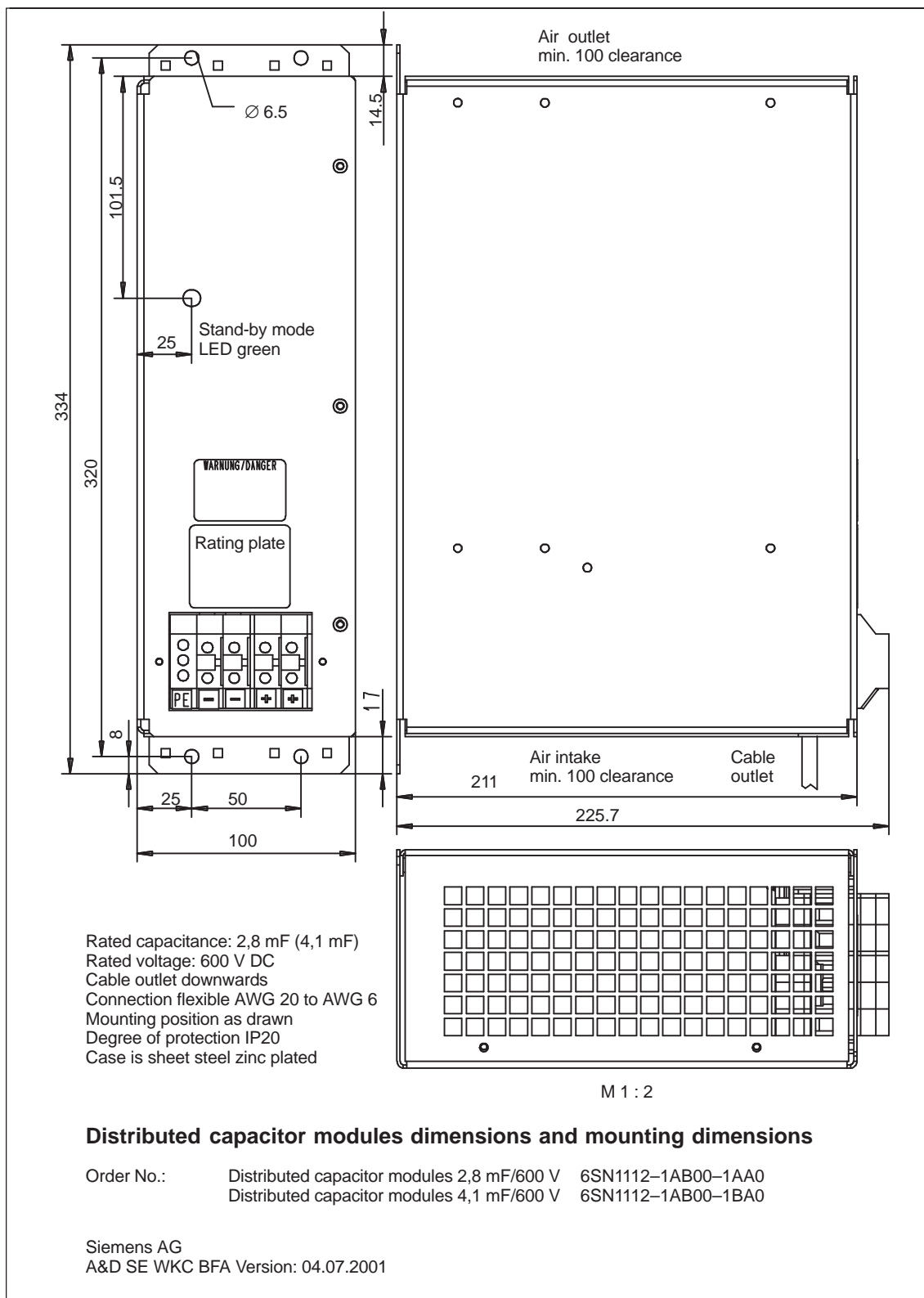

Fig. 12-59 Distributed capacitor modules, 6SN1112-1AB00-1xA0

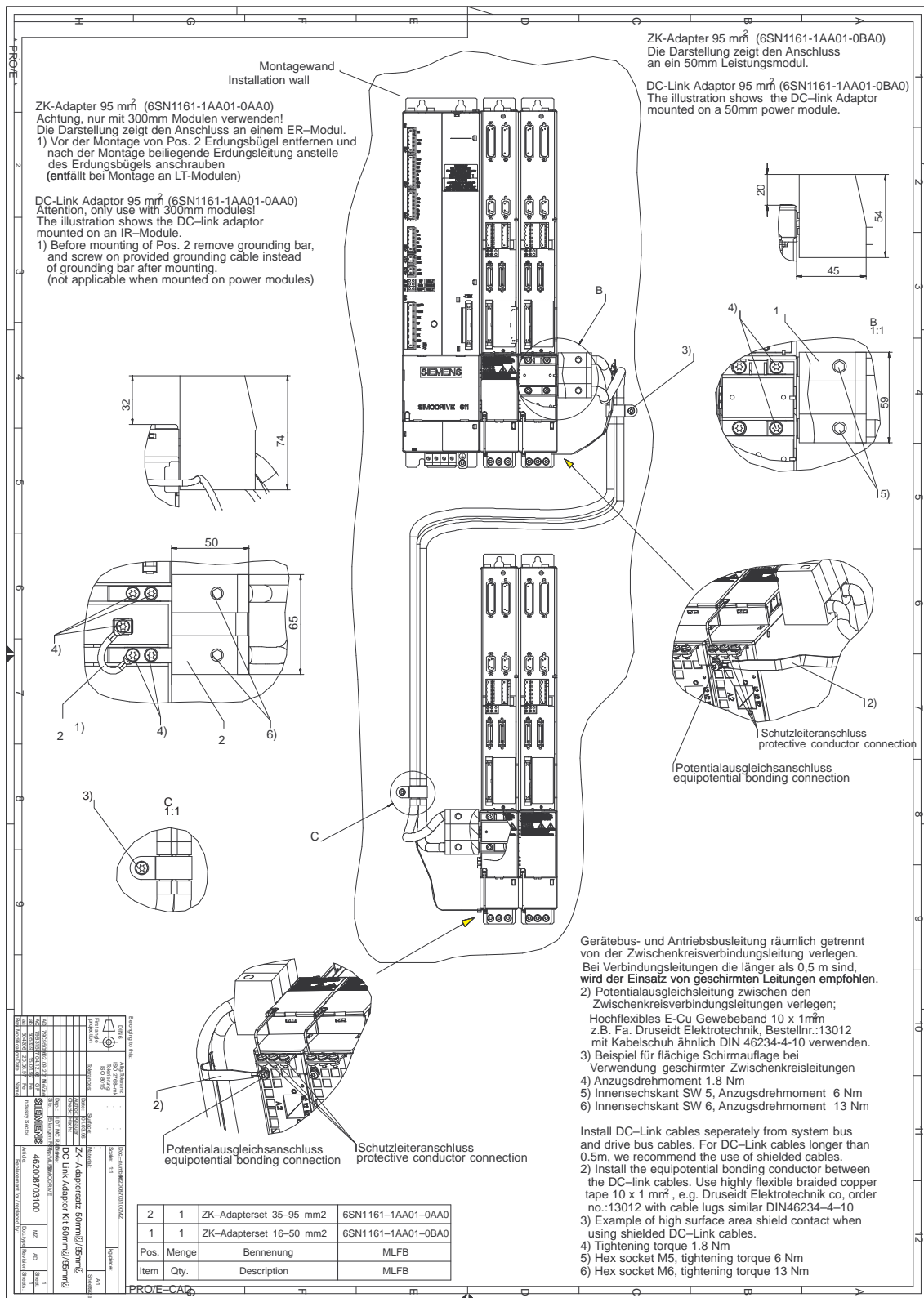

Fig. 12-60 DC link adapter set 16...50 mm<sup>2</sup> and 35...95 mm<sup>2</sup> 6SN1161-1AA01-0BA0/ -0AA0

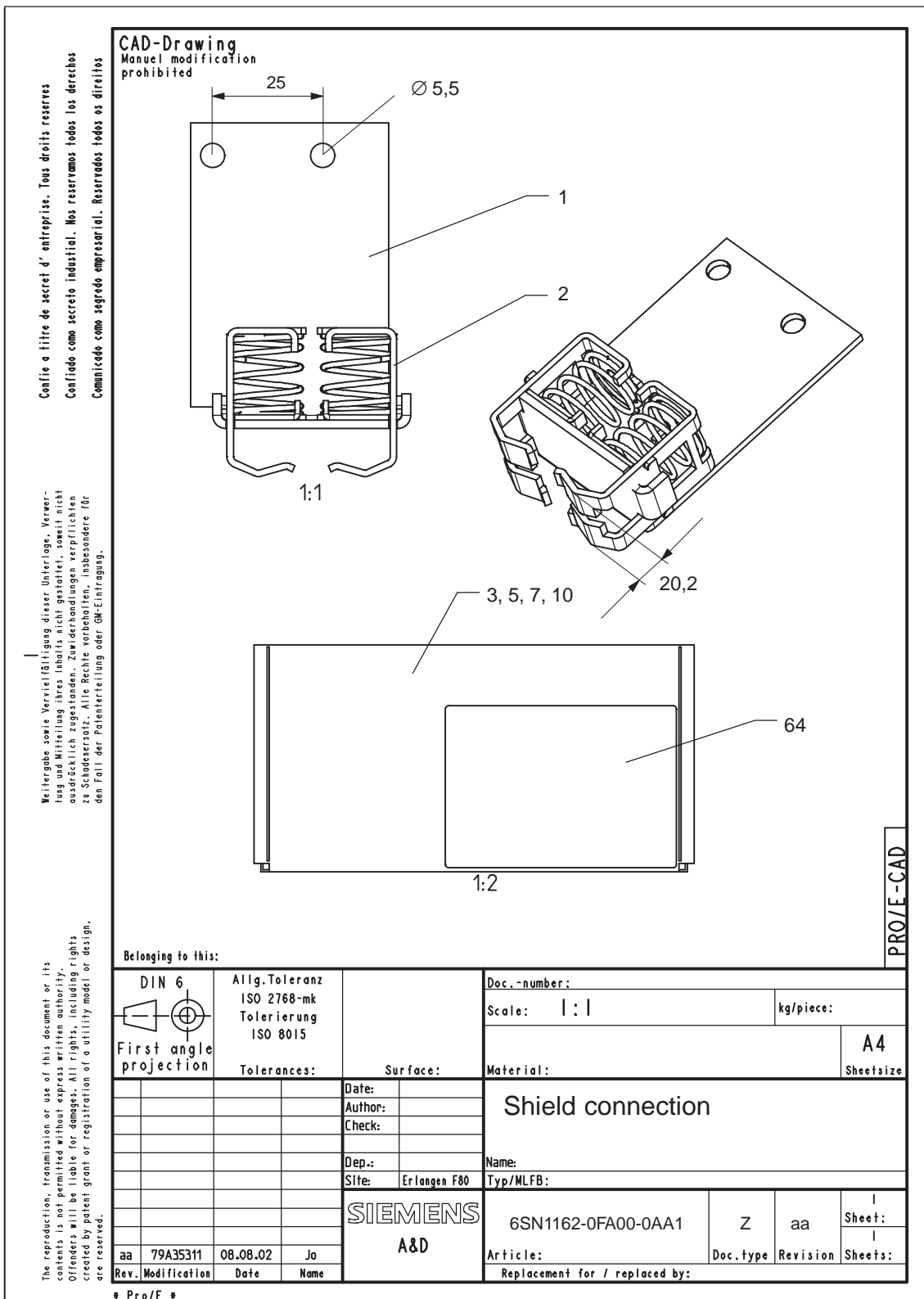

Fig. 12-61 Shield connection 6SN1162-0FA00-0AA1 (dimension drawing)

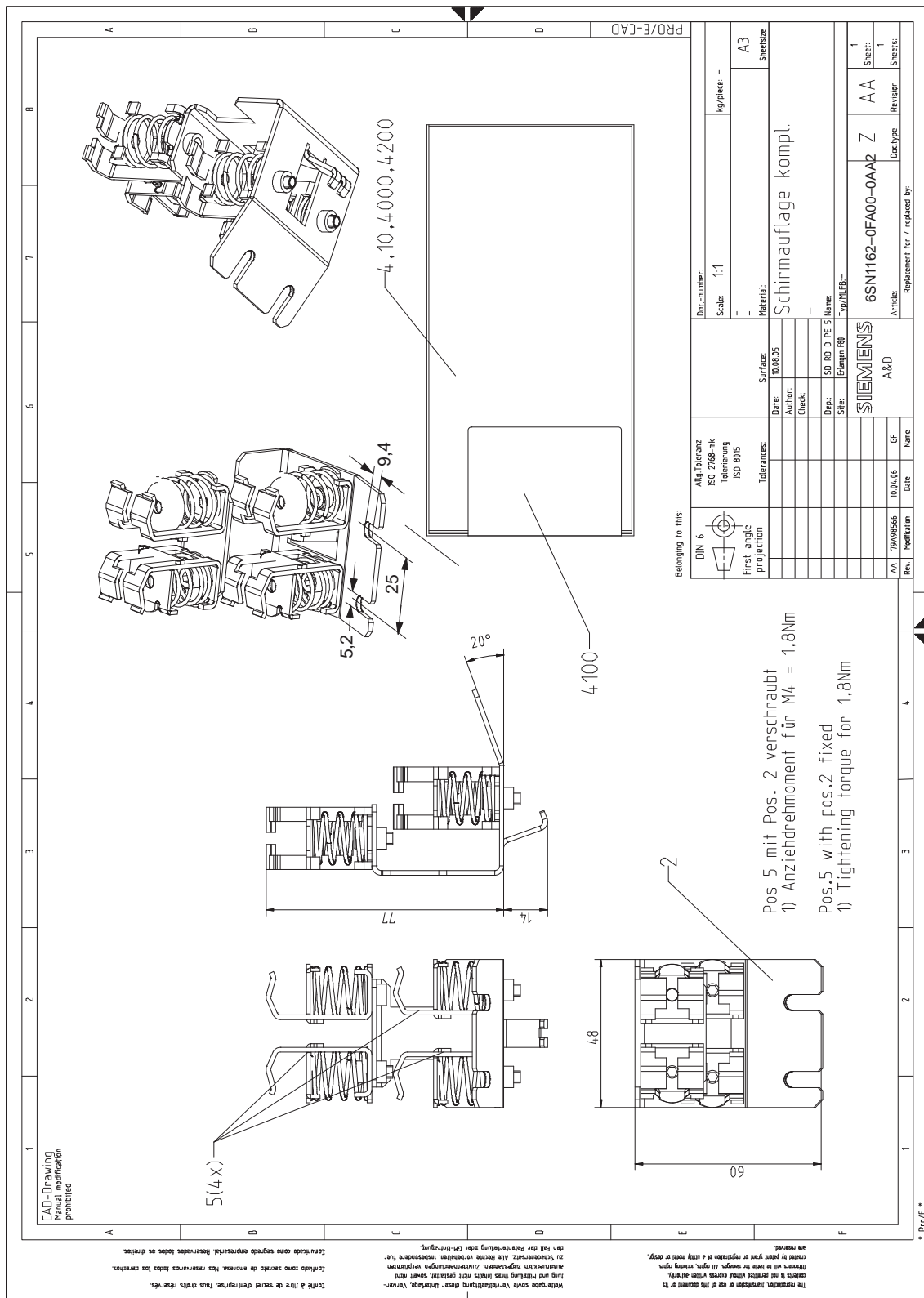

Fig. 12-62 Shield connection 6SN1162-0FA00-0AA2 (dimension drawing)

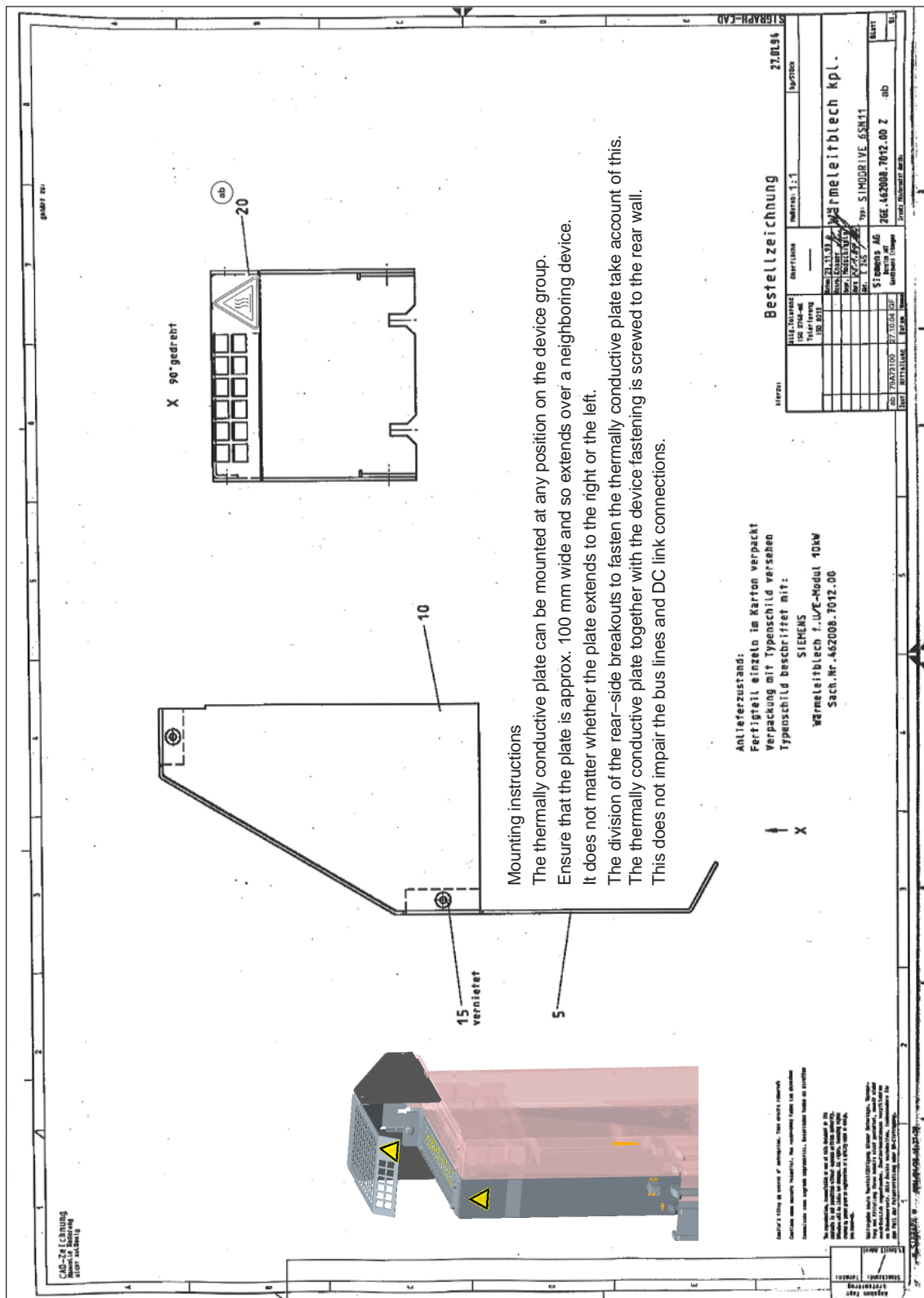

Fig. 12-63 Thermally conductive plate 6SN1162-0BA01-0AAx (dimension drawing)



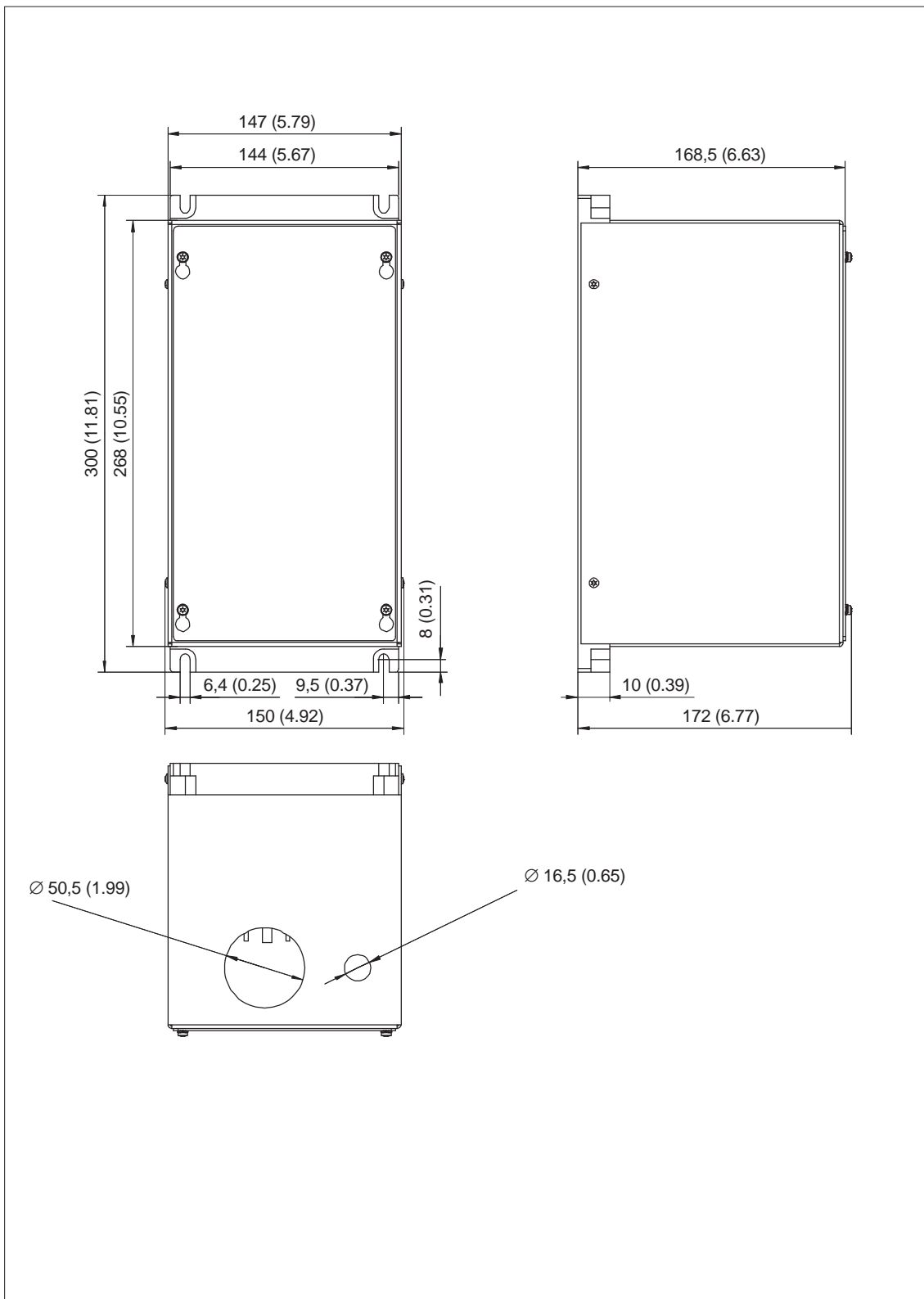

Fig. 12-64 VPM 120, dimension drawing 6SN1113-1AA00-1JAx

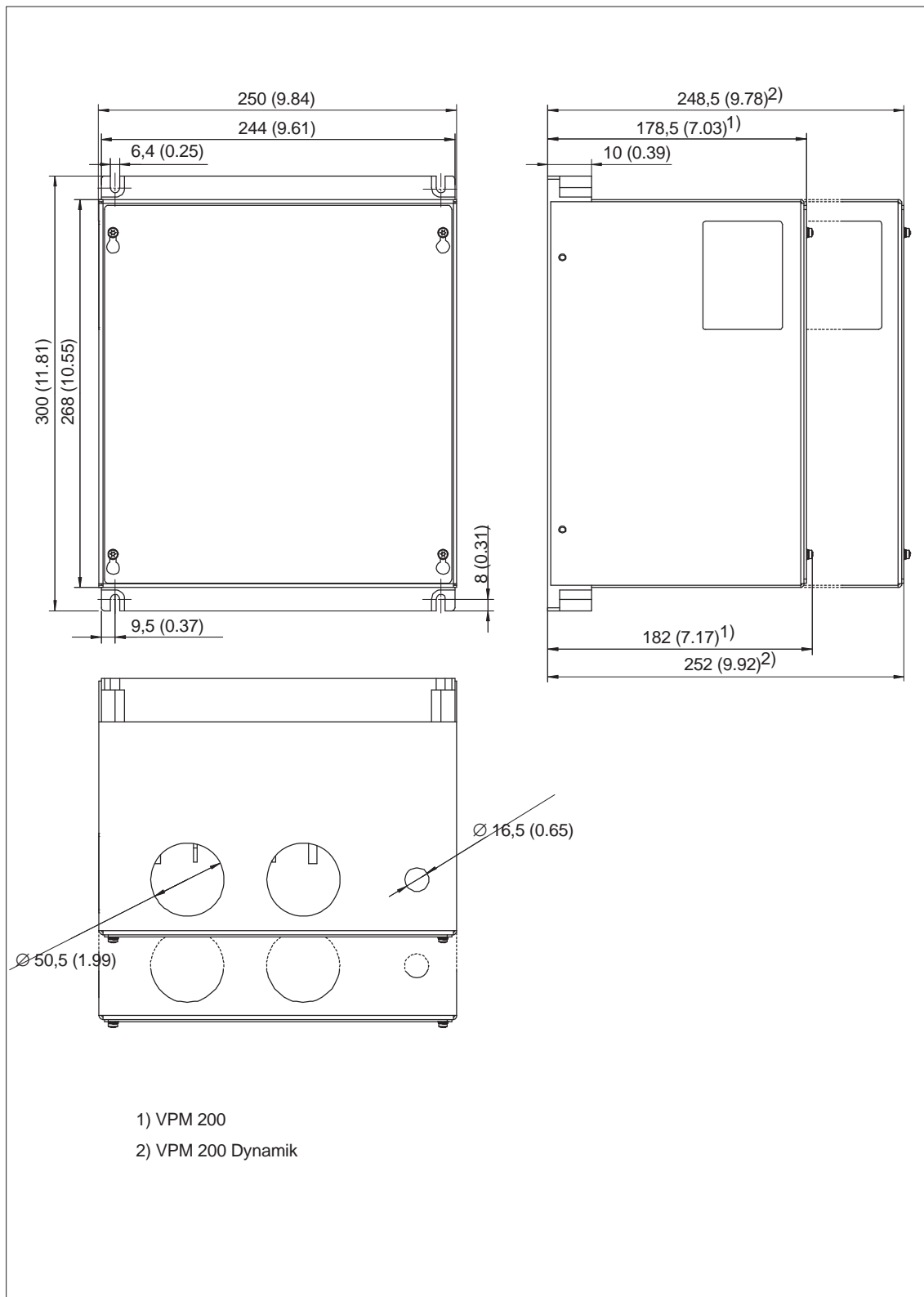

Fig. 12-65 VPM 200/VPM 200 DYNAMIK, dimension drawing 6SN1113-1AA00-1xAx



## Abbreviations and Terminology

<b>611 D</b>	D for digital (SIMODRIVE 611 digital)
<b>611 U</b>	U for universal (SIMODRIVE 611 universal)
<b>611 UE</b>	UE for universal eco (SIMODRIVE 611 universal E)
<b>611 U HR</b>	HR for High Resolution
<b>ABS</b>	Absolute
<b>ADC</b>	Analog-to-digital converter
<b>AIE</b>	Angular incremental encoder interface
<b>Analog control</b>	Control board with analog interface
<b>AO</b>	Analog output
<b>ARM</b>	Rotating induction motor
<b>ASM</b>	Induction motor
<b>COM</b>	Communications module
<b>Commissioning</b>	Commissioning
<b>CPU</b>	Central processing unit
<b>DAC</b>	Digital-to-analog converter
<b>DC link</b>	DC link
<b>Digital control</b>	Control board with digital interface
<b>DM</b>	Direct measuring system (encoder 2)
<b>DMS</b>	Direct measuring system
<b>DP</b>	Distributed periphery (I/O)
<b>Drive module</b>	General term for main spindle and feed module
<b>DSC</b>	Dynamic servo control
<b>EMC</b>	Electromagnetic compatibility
<b>EMF</b>	Electromotive force
<b>EN+</b>	Enable voltage +24 V

<b>EN-</b>	Reference for the enable voltage
<b>EnDat</b>	Encoder-data interface (bidirectional synchronous–serial interface)
<b>EP</b>	Electronic assessment factor
<b>ESD</b>	Modules/components that can be destroyed by electrostatic discharge
<b>ET 200</b>	Peripheral devices (I/O) from the SIMATIC range which can be coupled via PROFIBUS
<b>External cooling</b>	Module with heatsink that extends beyond the rear panel, cooling on the customer side
<b>FDD</b>	Feed drive
<b>FD module</b>	Feed module
<b>FG</b>	Function generator
<b>Hardware</b>	Hardware
<b>HEX</b>	Abbreviation for a hexadecimal number
<b>HFD</b>	High–frequency damping
<b>HGL</b>	High–resolution actual position value (ramp–function generator)
<b>HWE</b>	Hardware limit switch
<b>I</b>	Input
<b>Id</b>	Field–generating current
<b>IF</b>	Pulse enable
<b>IM</b>	Induction motor without encoder (IM operation)
<b>IM</b>	Indirect measuring system (motor measuring system)
<b>Internal cooling</b>	Modules with integrated heatsink, in some cases with hose connection
<b>IPO</b>	Interpolator
<b>Iq</b>	Torque–generating current
<b>I/R module</b>	Infeed/regenerative feedback module with regulated DC link voltage
<b>KL</b>	Terminal
<b>Kv</b>	Position loop gain (Kv factor)
<b>L2DP</b>	L2 distributed I/O
<b>LED</b>	Light emitting diode
<b>MCU</b>	Motion Control Unit (single–axis positioning board)

<b>MLFB</b>	Machine readable product designation (Order No.)
<b>Monitoring module</b>	Monitoring module
<b>MPI</b>	Multi Point Interface
<b>MSD module</b>	Main spindle module
<b>MSD option</b>	Option module, main spindle options for FD module
<b>MSR</b>	Dimension system grid: Smallest position unit
<b>MT</b>	Machine tool
<b>n</b>	Nominal values = rated value (index)
<b>n<sub>act</sub></b>	Actual speed value
<b>N</b>	Line values (index)
<b>NC</b>	Numerical control
<b>NCU</b>	Numerical control unit
<b>NE</b>	Line infeed
<b>NE module</b>	Line supply infeed module (general term for UI and I/R modules)
<b>n<sub>set</sub></b>	Speed setpoint
<b>O</b>	Output
<b>OC</b>	Operating condition
<b>OPI</b>	Operator panel interface
<b>PELV</b>	Protective extra low voltage
<b>PG</b>	Programming device
<b>PLC</b>	Programmable logic controller
<b>PLI</b>	Pole position identification
<b>PM module</b>	Power module
<b>PO</b>	POWER ON
<b>PPU</b>	Protected power unit
<b>PR module</b>	Pulsed resistor module
<b>PROFIBUS</b>	Process field bus: Serial data bus
<b>PU</b>	Packaging unit
<b>RCCB</b>	Residual current circuit breaker
<b>RF</b>	Controller enable

<b>RLI</b>	Rotor position identification, corresponds to the pole position identification (PLI)
<b>SLM</b>	Synchronous linear motor
<b>SRM</b>	Synchronous rotating motor
<b>SS</b>	Interface
<b>SSI</b>	Synchronous serial interface
<b>SVE</b>	Current amplification electronics
<b>SW</b>	Software
<b>SWE</b>	Software limit switch
<b>U<sub>DC link</sub></b>	DC link voltage
<b>UI</b>	Uncontrolled infeed
<b>UI module</b>	Infeed module with non-regulated DC link voltage and pulsed resistor
<b>VPM</b>	VP module, module to limit the DC link voltage when a fault condition occurs (VPM: Voltage Protection Module)
<b>VPM</b>	Voltage protection module
<b>V<sub>pp</sub></b>	Peak-to-peak voltage
<b>xact</b>	Actual position value
<b>xset</b>	Position setpoint value



## References

### General Documentation

<b>/BU/</b>	SINUMERIK & SIMODRIVE Catalog NC 60 • 2009 Order No.: E86060-K4460-A101-B3 Order No.: E86060-K4460-A101-B3 -7600 (English)
<b>/KT101/</b>	SITOP power/LOGO!power power supplies Catalog NC 10.1 • 2009 Order No.: E86060-K2410-A101-A7
<b>/KT654/</b>	SIMODRIVE and POSMO Catalog NC 65.4 • 2005 Order No.: E86060-K5165-A401-A2
<b>/ZI/</b>	MOTION-CONNECT Connections & System Components for SIMATIC, SINUMERIK, MASTERDRIVES, and SIMOTION Catalog NC Z Order No.: E86060-K4490-A101-B1 Order No.: E86060-K4490-A101-B1-7600 (English)
<b>/NSK/</b>	Low-Voltage Switchgear Automation and Drives Catalog NS K Order No.: E86060-K1002-A101-A1
<b>/PD10/</b>	Transformers SIDAC-T Catalog PD 10 2001 Order No.: E86060-K2801-A101-A1
<b>/HBSI/</b>	Safety Integrated The Safety Program for Industries of the World Application Manual Order No.: 6ZB5000-0AA01-0BA1



## User Documentation

/PI/

### PCIN 4.4

Software for the data transfer to/from MMC module

Order No.: 6FX2 060 4AA00-4XB0 (German, English, French)

Ordering location: WK Fürth

## Manufacturer/Service Documentation

---

### Note

A list of additional documents, updated on a monthly basis, is available on the Internet for the available languages at:

<http://www.siemens.com/motioncontrol>

Select the menu items "Support" → "Technical Documentation" →  
"Ordering Documentation" → "Printed Documentation".

---



# Certificates/Declarations of Conformity



You can find the EC declaration of conformance for the EMC directive in the Internet at:

<http://support.automation.siemens.com>

There, as search term, enter the number 15257461 or contact the local Siemens office in your region.

You can find the EC declaration of conformance for the Low-Voltage-Directive in the Internet at:

<http://support.automation.siemens.com>

There, as search term, enter the number 22383669.

---

## Note

Listing and file names regarding UL/CSA/FM certification of SIEMENS SIMODRIVE products can be found under:

<http://support.automation.siemens.com>

There, as search term enter "SIMODRIVE certificates".

---

---

## Note

Certificates, Declarations of Conformity, test certificates, such as CE, UL, Safety Integrated, etc., are valid only when the components described in the associated catalogs and this configuration guide are used, and installed in accordance with the configuring guidelines and used properly!

In other cases, such documents must be prepared again by the vendor of these products!

---





# Certificate

Certificate no. CU 72052622 01

---

<p><b>License Holder:</b> Siemens AG, A&amp;D MC Frauenauracher Str. 80  91056 Erlangen Germany</p>	<p><b>Manufacturing Plant:</b> Siemens AG, A&amp;D MC Frauenauracher Str. 80  91056 Erlangen Germany</p>
-------------------------------------------------------------------------------------------------------------------------	------------------------------------------------------------------------------------------------------------------------------

---

<p><b>Test report no.:</b> USA-GG 30472653 002</p>	<p><b>Client Reference:</b> Dietmar Wanner</p>
<p><b>Tested to:</b> UL 508:1999 R12.03 UL 508C R7.03 NFPA 79:2002 CAN/CSA C22.2 No. 14-95 IEC 61508-1:1998 IEC 61508-2:2000 IEC 61508-3:1998</p>	

---

**Certified Product:** Ind. Ctrl. Equip. for Safety-related Functions **License Fee - Units**

**Listing Category:** Industrial Control Equipment for Safety-Related Functions and E-Stop (per NFPA 79):  
**Model Designation:** SINUMERIK Safety Integrated Drive Control, consisting of:  
     SINUMERIK 840D powerline or  
     SINUMERIK 840DE powerline and  
     SIMODRIVE 611 digital

**Rated Voltage:** 3 AC 480V, 60Hz  
**Rated Power:** 3.7kW to 156kW  
**Protection Class:** I

**Special Remarks:** To be installed according to the licensee's installation instructions. Replaces Certificate CU72042952.  
**Appendix:** 1

Inh. = 744937 / Deb. = 201200 / Fert. = 744937

---

<p><b>Licensed Test mark:</b></p> 	<p style="text-align: center;"><b>Signatures</b></p> <div style="display: flex; justify-content: space-around;"> <div style="text-align: center;">               Stephan Schmitt              President         </div> <div style="text-align: center;">               Dipl.-Ing. M. Raap              QA Certification Officer         </div> </div>	<p><b>Date of Issue (day/mo/yr)</b> 19/10/2005</p>
-----------------------------------------------------------------------------------------------------------------------	----------------------------------------------------------------------------------------------------------------------------------------------------------------------------------------------------------------------------------------------------------------------------------------------------------------------------------------------------------------------------------------------------------------------------------------------------------------------------------------------------------------------------------------------	--------------------------------------------------------

TUV Rheinland of North America, Inc., 12 Commerce Road, Newtown, CT 06470, Tel (203) 426-0888 Fax (203) 426-4009

Fig. C-1 Certificate, SINUMERIK Safety Integrated

# SIEMENS

## Manufacturer's Declaration

Manufacturer: SIEMENS AG

Address: SIEMENS AG; Industry DT MC  
Frauenauracher Straße 80  
D-91056 Erlangen  
Germany

Product description: **SIMODRIVE 611**  
(for included hardware and software releases see annex)

The above mentioned product may be used in systems in order to implement the functional safety functions "Safe Stop" (STO) and "Safe Stop 1" (SS1) that fulfil the requirements of PLe and category 3 according to [1]. The function STO and SS1 correspond to stop category 0 and stop category 1 according to [2], respectively.

### Reference number

[1] EN ISO13849 part 1 (2007)  
[2] EN 60204 (2006)

Erlangen, August 4<sup>th</sup> 2011

G. Bock

Vice President Research and Development MC  
Name, function, signature

*in Vertretung für*  
T. Heinzlmann

Vice President Quality Management  
Name, function, signature

Fig. C-2 Safety Manufacturers Declaration SIMODRIVE

SIEMENS AG	August 4 <sup>th</sup> 2011
<b>Index</b>	
1	Hardware ..... 3
1.1	SIMODRIVE 611 Digital ..... 3
1.2	SIMODRIVE 611 Universal ..... 3
2	Restrictions ..... 4
3	Boundary Conditions ..... 5

Manufacturer's Declaration – MASTERDRIVES page 2/5

Fig. C-3 Safety Manufacturers Declaration SIMODRIVE, continued

SIEMENS AG

August 4<sup>th</sup> 2011

## 1 Hardware

### 1.1 SIMODRIVE 611 Digital

Type	Order Purchase Number (MLFB)	
	Description	MLFB
611D	high performance, 2 axis	6SN1118-0DK23-0AA2
611D	high performance, 1 axis	6SN1118-0DJ23-0AA2
611D	high standard, 2 axis	6SN1118-0DM33-0AA2
611D	high performance, 2 axis	6SN1118-0DK21-0AA2
611D	high performance, 1 axis	6SN1118-0DJ21-0AA2
611D	high standard, 2 axis	6SN1118-0DM31-0AA2

### 1.2 SIMODRIVE 611 Universal

Type	Order Purchase Number (MLFB)	
	Description	MLFB
611U	1 axis	6SN1118-0NJ01-0AA1
611U	1 axis	6SN1118-1NJ01-0AA1
611U	2 axis	6SN1118-0NK01-0AA1
611U	2 axis	6SN1118-1NK01-0AA1
611U	2 axis	6SN1118-0NH01-0AA1
611U	2 axis	6SN1118-1NH01-0AA1

### 1.3 SIMODRIVE Infeed Modules

Type	Order Purchase Number (MLFB)	
	Description	MLFB
UI Infeed Module (5kW)	unregulated, internal cooling	6SN1146-1AB00-0BA1
UI Infeed Module (10kW)	unregulated, internal cooling	6SN1145-1AA01-0AA2
UI Infeed Module (28kW)	unregulated, internal cooling	6SN1145-1AA00-0CA0
I/R Infeed Module (16kW)	regulated, internal cooling	6SN1145-1BA01-0BA2
I/R Infeed Module (36kW)	regulated, internal cooling	6SN1145-1BA02-0CA2
I/R Infeed Module (55kW)	regulated, internal cooling	6SN1145-1BA01-0DA1
I/R Infeed Module (80kW)	regulated, internal cooling	6SN1145-1BB00-0EA1
I/R Infeed Module (120kW)	regulated, internal cooling	6SN1145-1BB00-0FA1
UI Infeed Module (5kW)	unregulated, external cooling	6SN1146-1AB00-0BA1
UI Infeed Module (10kW)	unregulated, external cooling	6SN1145-1AA01-0AA2
UI Infeed Module (28kW)	unregulated, external cooling	6SN1146-1AB00-0CA0
I/R Infeed Module (16kW)	regulated, external cooling	6SN1146-1BB01-0BA2
I/R Infeed Module (36kW)	regulated, external cooling	6SN1146-1BB02-0CA2
I/R Infeed Module (55kW)	regulated, external cooling	6SN1146-1BB00-0DA1
I/R Infeed Module (80kW)	regulated, external cooling	6SN1146-1BB00-0EA1
I/R Infeed Module (120kW)	regulated, external cooling	6SN1146-1BB00-0FA1
I/R Infeed Module (55kW)	regulated hose cooling	6SN1145-1BB00-0DA1
I/R Infeed Module (80kW)	regulated hose cooling	6SN1145-1BB00-0EA1
I/R Infeed Module (120kW)	regulated hose cooling	6SN1145-1BB00-0FA1

Manufacturer's Declaration – MASTERDRIVES

page 3/5

Fig. C-4 Safety Manufacturers Declaration SIMODRIVE, continued

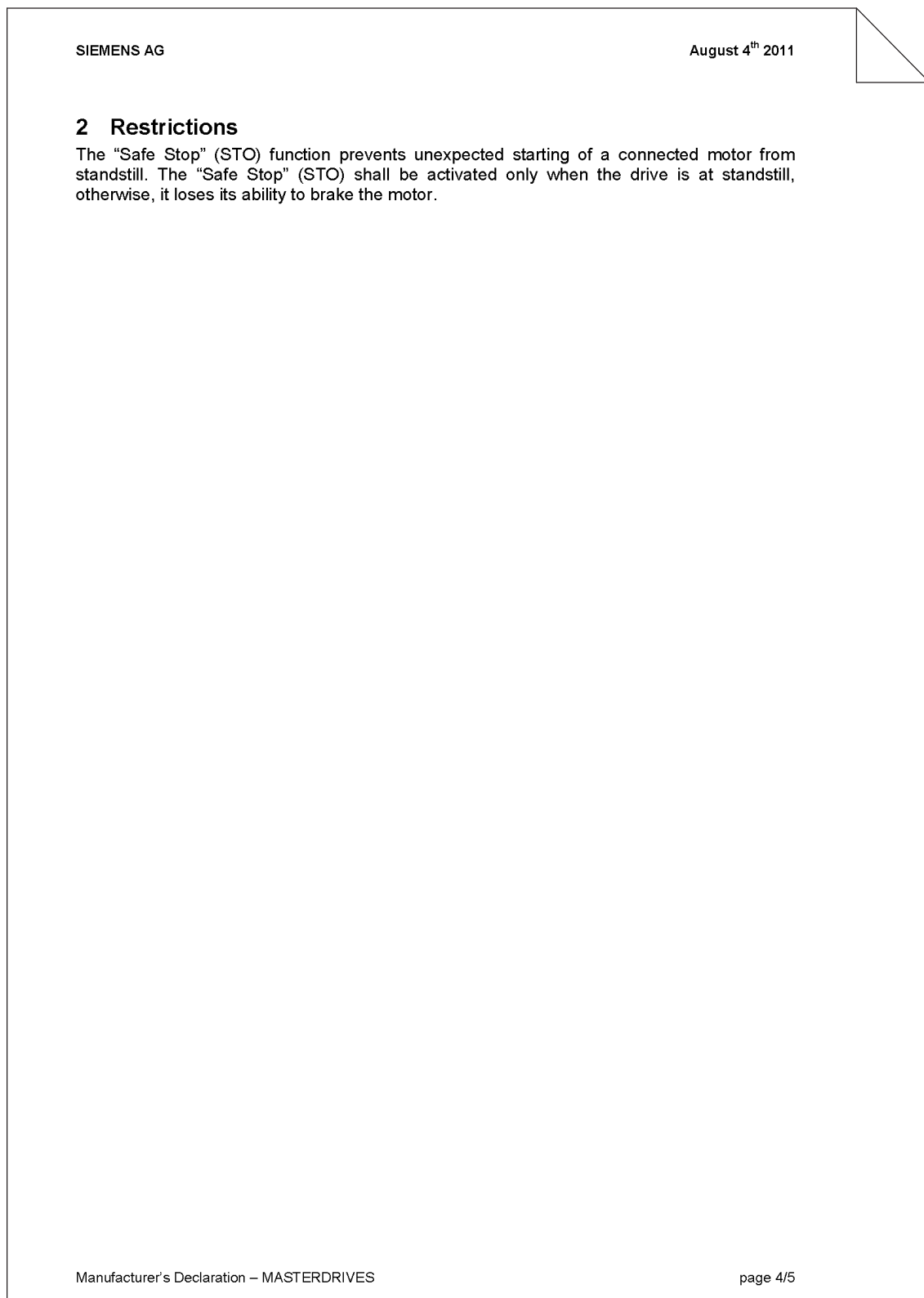

Fig. C-5 Safety Manufacturers Declaration SIMODRIVE, continued

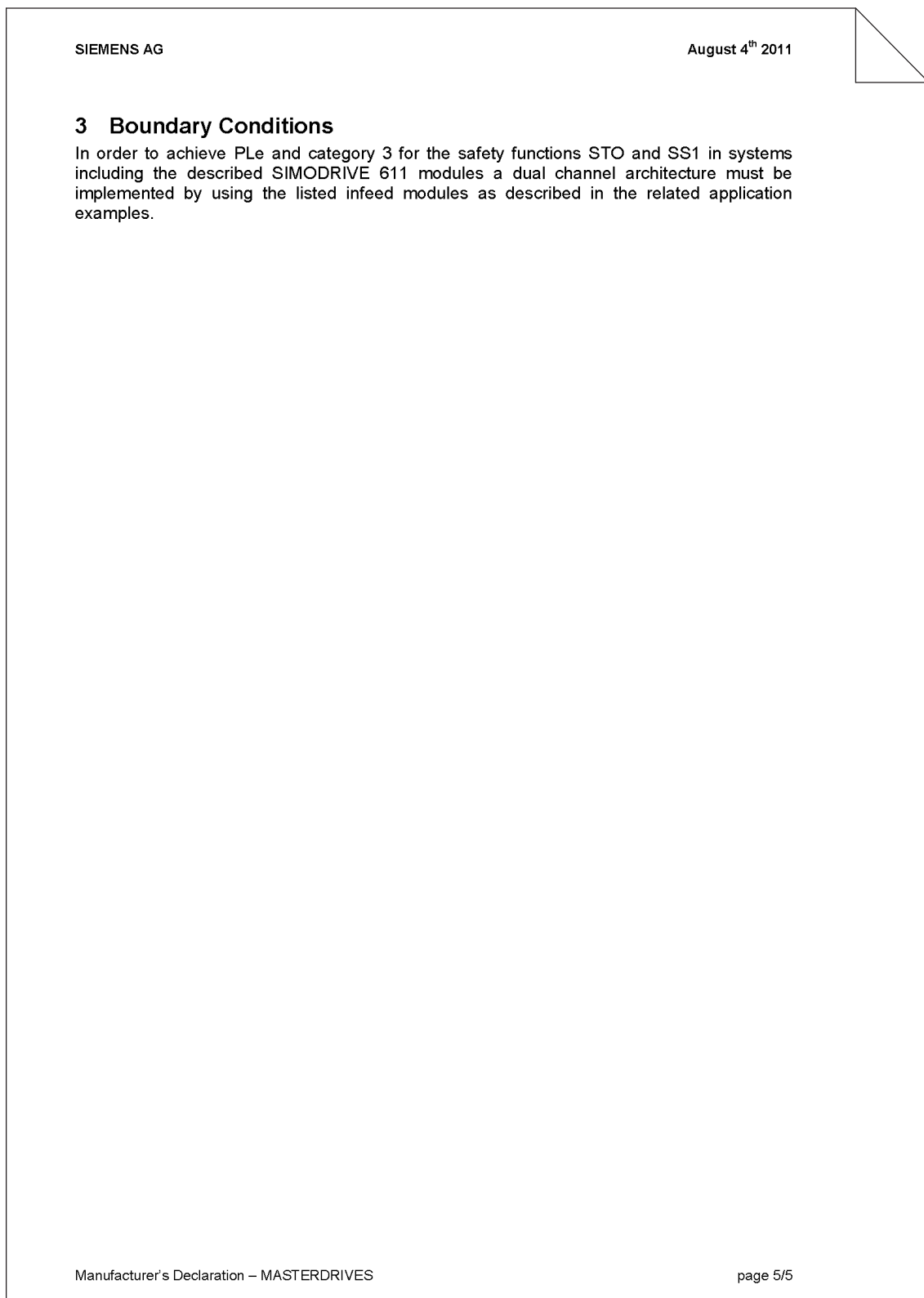

Fig. C-6 Safety Manufacturers Declaration SIMODRIVE, continued



**SIEMENS**

Extract, following

## EG-Konformitätserklärung EC Declaration of Conformity

Nr. / No. 664.E002.02

Hersteller: Manufacturer:	Siemens AG, I DT MC Frauenauracher Straße 80 91056 Erlangen Deutschland / Germany
Produktfamilien: Product Families:	<p><b>SINUMERIK</b> 802D, 802S, 805, 805SM-P, 805SM-TW, 810, 810D, 820, 828D, 828D sl, 840C, 840CE, 840D, 840DE, 840Di, 840D sl, 840Di sl, FM NC, YS830DI, YS840DI</p> <p><b>SIMOTION</b> C230, C230-2, C240, C240PN, P320-3, P350, P350-x, D410DP, D410PN, D425, D435, D445, D455, CX32, E510</p> <p><b>SIMATIC</b> FM 353, FM 354, FM 357</p> <p><b>SIROTEC</b> RCM1D, RCM1P</p> <p><b>SIMODRIVE</b> 610, 611, MCU, FM STEPDRIVE, POSMO A/ SI/ CA/ CD</p> <p><b>SINAMICS</b> S110, S120</p>

**Die bezeichneten Produktfamilien stimmen mit den Vorschriften folgender Europäischer Richtlinien überein:**

*The indicated product families are in conformance with the regulations of the following European Directives:*

- |             |                                                                                                                                               |
|-------------|-----------------------------------------------------------------------------------------------------------------------------------------------|
| 2004/108/EG | Richtlinie des Rates zur Angleichung der Rechtsvorschriften der Mitgliedsstaaten über die elektromagnetische Verträglichkeit (EMV-Richtlinie) |
| 2004/108/EC | Council Directive on the harmonization of the laws of the member states relating to electromagnetic compatibility (EMC Directive)             |
- Weitere Angaben über die Einhaltung dieser Richtlinie enthält Anhang EMV.  
Additional details concerning adherence to this Directive is provided in Appendix EMC.**

Siemens Aktiengesellschaft

Siemens Aktiengesellschaft

Erlangen, 28. Feb. 2011

Erlangen, 28. Feb. 2011

i.V.



Hr. Bock, Guenther  
Vice President I DT/ MC RD

Name, Funktion  
Name, function

Unterschrift  
signature

i.V.



Hr. Heinzlmann, Thomas  
Vice President I DT/ MC QM

Name, Funktion  
Name, function

Unterschrift  
signature

Die Anhänge EMV (I) und (II) sind Bestandteil dieser Erklärung. Diese Erklärung bescheinigt die Übereinstimmung mit den genannten Richtlinien, ist jedoch keine Zusicherung von Eigenschaften im Sinne des Produkthaftungsgesetzes. Die Sicherheitshinweise der mitgelieferten Produktdokumentation sind zu beachten.  
*Appendices EMC (I) and (II) are part of this declaration. While this declaration indicates conformance with the European Directives listed; it does not imply a guarantee with respect to the product liability laws. The safety notes included with the product documentation must be observed*

Siemens Aktiengesellschaft: Vorsitzender des Aufsichtsrats: Gerhard Cromme; Vorstand: Peter Löscher, Vorsitzender; Wolfgang Dehen, Brigitte Ederer, Joe Kaeser, Barbara Kux, Hermann Requardt, Siegfried Russwurm, Peter Y. Solmsen  
Sitz der Gesellschaft: Berlin und München, Deutschland; Registergericht: Berlin Charlottenburg, HRB 12300, München, HRB 6684  
WEEE-Reg.-Nr. DE 23691322

Nr. / No. 664.E002.02

section 1- page 1 of 1

**SIEMENS**

**Anhang EMV (I)**  
*Appendix EMC (I)*  
**zur EG-Konformitätserklärung**  
*for EC DECLARATION of CONFORMITY*  
 Nr. / No. 664.E002.02

**Produktfamilien:**  
*Product Families:*

**SINUMERIK** 802D, 802S, 805, 805SM-P, 805SM-TW,  
 810, 810D, 820, 828D, 828D sl, 840C, 840CE, 840D,  
 840DE, 840Di, 840D sl, 840Di sl, FM NC, YS830DI,  
 YS840DI

**SIMOTION** C230, C230-2, C240, C240PN, P320-3,  
 P350, P350-x, D410DP, D410PN, D425, D435, D445,  
 D455, CX32, E510

**SIMATIC** FM 353, FM 354, FM 357

**SIROTEC** RCM1D, RCM1P

**SIMODRIVE** 610, 611, MCU, FM STEPDRIVE, POSMO  
 A/ SI/ CA/ CD

**SINAMICS** S110, S120

Die Übereinstimmung der bezeichneten Produkte mit den Vorschriften der Richtlinie 2004/108/EG wird nachgewiesen durch die vollständige Einhaltung folgender Normen.

*Conformity of the designated products with the regulations of Directive 2004/108/EC demonstrated by adherence to the following standards.*

**Harmonisierte Europäische Normen:**

*Harmonized European Standards:*

Referenznummer <i>Reference number</i>	Ausgabedatum <i>Edition</i>
<b>EN 61800-3</b>	<b>2004</b>

Die Installationshinweise gemäß Handbuch sind zu beachten.  
*The installation instructions according handbook are to be fulfilled.*

**SIEMENS**

**Anhang EMV (II)**  
*Appendix EMC (II)*  
**zur EG-Konformitätserklärung**  
*for EC DECLARATION of CONFORMITY*  
Nr. / No. 664.E002.02

Dieser Anhang beschreibt die Anlagenkonfigurationen / Komponenten, bei denen die Einhaltung der Richtlinie gemäß Anhang EMV (I) nachgewiesen wurde.

*This appendix describes the system configurations / components, which meet the requirements of the directives according to appendix EMC (I).*

# SIEMENS

## A9: SINUMERIK 840D/ SIMODRIVE 611 mit digitaler Sollwert-Schnittstelle SINUMERIK 840D/ SIMODRIVE 611 with digital setpoint interface

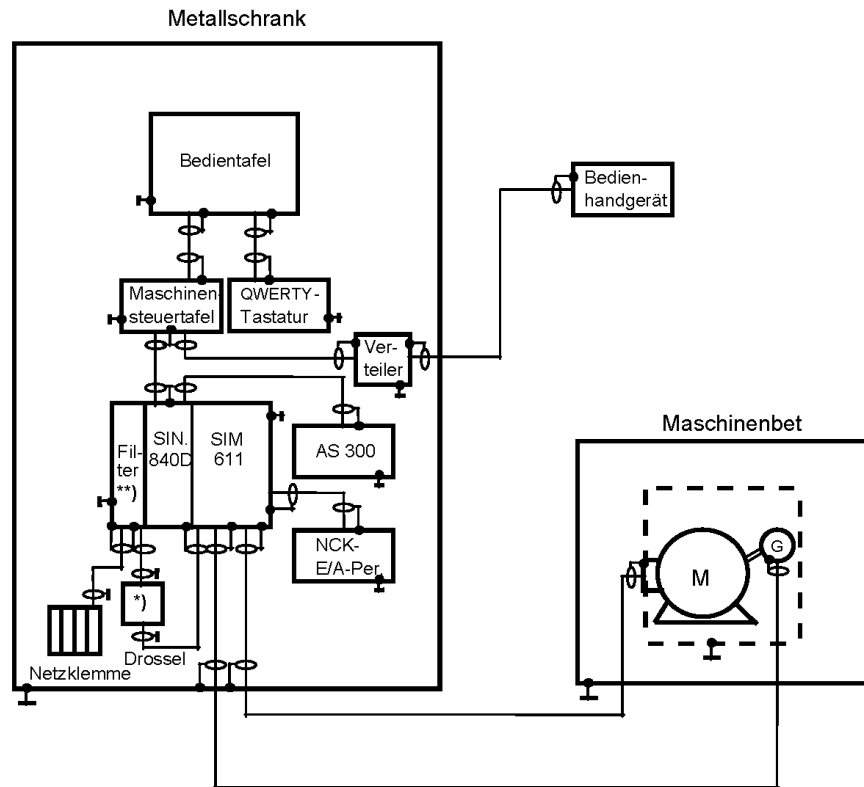

\*) bei E/R-Modul und UE-Modul 28kW / for E/R module and UE module 28 kW

\*\*) Filter im Modulverband oder separate / Filter in the module group or separately

- Alle Komponenten, die gemäß Bestellunterlage für den Anlagenverbund von SINUMERIK 840D und SIMODRIVE 611D zugelassen sind, erfüllen im Verbund die EMV-Richtlinie
- In der Skizze der Anlagenkonfiguration werden nur die grundsätzlichen Maßnahmen zur Einhaltung der EMV-Richtlinie einer typischen Anlagenkonfiguration aufgezeigt.
- Zusätzlich, besonders bei Abweichung von dieser Anlagenkonfiguration, sind die Installationshinweise für EMV-gerechten Anlagenaufbau der Produktdokumentation und der EMV-Aufbaurichtlinie (Bestell Nr.: 6FC5297-□AD30-0AP□) zu beachten.
- *All components, which according to the ordering information, are permitted for the system grouping of SINUMERIK 840D and SIMODRIVE 611D, also satisfy the EMC directive as a group.*
- *In the system configuration sketch, only the basic measures for compliance with the EMC directive of a typical system configuration are displayed.*
- *The installation notes for compliance with EMC in the product documentation and the EMC installation directive (order no.: 6FC5297-□AD30-0AP□) should also be taken into account, especially when the configuration differs from this system configuration.*

# SIEMENS

## A10: SINUMERIK 840C/ SIMODRIVE 611 mit analoger und digitaler Sollwert-Schnittstelle SINUMERIK 840C/ SIMODRIVE 611 with analogue and digital setpoint interface

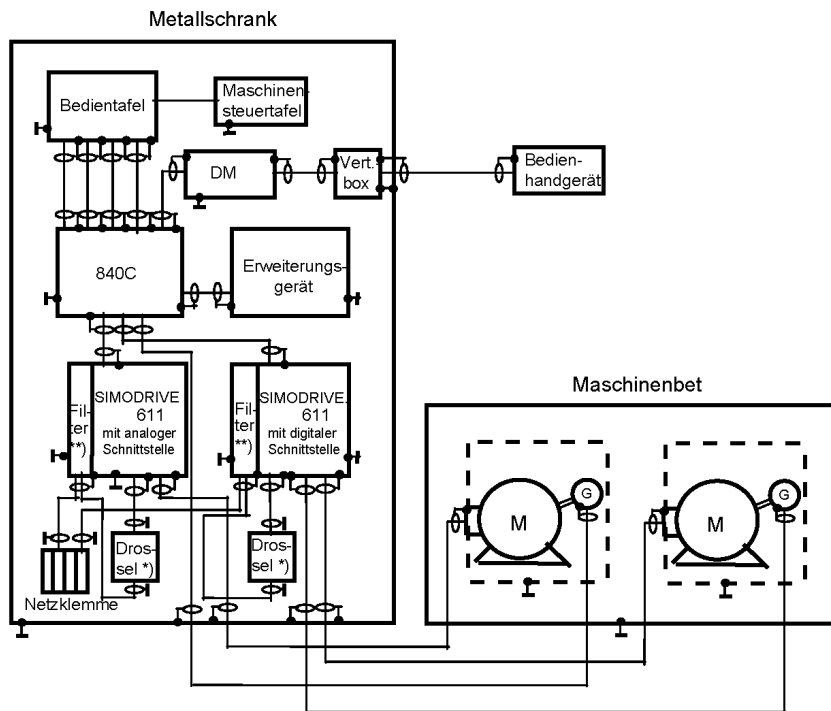

\*) bei E/R-Modul und UE-Modul 28kW / for E/R module and UE module 28 kW

\*\*) Filter im Modulverband oder separate / Filter in the module group or separately

- Alle Komponenten, die gemäß Bestellunterlage für den Anlagenverbund von SINUMERIK 840C und SIMODRIVE 611A oder D zugelassen sind, erfüllen im Verbund die EMV-Richtlinie
- In der Skizze der Anlagenkonfiguration werden nur die grundsätzlichen Maßnahmen zur Einhaltung der EMV-Richtlinie einer typischen Anlagenkonfiguration aufgezeigt.
- Zusätzlich, besonders bei Abweichung von dieser Anlagenkonfiguration, sind die Installationshinweise für EMV-gerechten Aufwandaufbau der Produktdokumentation und der EMV-Aufbaurichtlinie (Bestell Nr.: 6FC5297-□AD30-0AP□) zu beachten.
- All components, which according to the ordering information, are permitted for the system grouping of SINUMERIK 840C and SIMODRIVE 611A or D, also satisfy the EMC directive as a group.
- In the system configuration sketch, only the basic measures for compliance with the EMC directive of a typical system configuration are displayed.
- The installation notes for compliance with EMC in the product documentation and the EMC installation directive (order no.: 6FC5297-□AD30-0AP□) should also be taken into account, especially when the configuration differs from this system configuration.

### EMC limit values in South Korea

이 기기는 업무용(A급) 전자파적합기기로서 판매자 또는 사용자는 이 점을 주의하시기 바라며, 가정외의 지역에서 사용하는 것을 목적으로 합니다.

For sellers or other user, please keep in mind that this device in an A-grade electromagnetic wave device. This device is intended to be used in areas other than home.

The EMC limit values to be maintained for Korea correspond to the limit values of the EMC product standard for variable-speed electric drives EN 61800-3, Category C2all or limit value class A, Group 1 according to EN55011.

With suitable supplementary measures, the limit values according to Category C2 or to limit value class A, Group 1 are maintained.

In addition, other measures, for example the use of an additional radio interference suppression filter (EMC filter) may be required. Further, measures for EMC-compliant installation of the system are described in detail in this manual or in the Configuration Manual EMC Installation Guideline.

It should be noted that the label attached to the device is always decisive regarding statements made about the standards that are complied with. ■



# Index

## Numbers

- 1-axis drive control, 4-83
- 1FT6 motors, 4-83
- 1PH motors, 4-83
- 2-axis drive control
  - High Performance, 4-83
  - High Standard, 4-83
  - Performance, 4-83
- 2-tier configuration, Control cabinet design, 9-344
- 3-phase fans, 6-173

## A

- Adapter set, 7-238
- Ambient conditions, 2-46
- Armature short-circuit, 8-293
- Arrangement of the modules, 2-42
- Autotransformer, 7-220

## B

- Braking module, 6-141, 6-191
  - Connection, 6-192
  - Technical specifications, 6-191

## C

- Cabinet, 1-28
- Cabinet wiring, 9-335
- Cable shield, 9-336
- Capacitor module, 1-26, 6-183
  - Charge/discharge times, 6-190
  - Configuration, 6-188
  - Connectable, 6-189
  - Technical specifications, 6-186
- CD, 4-91
- Certificates, vi
- Charge times, 6-190
- Circuit breakers, 7-215

## Circuit information

- Display elements (LEDs), 6-160
- Switch S1, 6-154
- Terminal 112, 6-157
- Terminal 19, 6-154
- Terminal 48, 6-154
- Terminal 63, 6-154
- Terminal 64, 6-155
- Terminal 9, 6-154
- Terminal P500, M500, 6-158
- Terminal R, 6-156
- Terminal X131, 6-157
- Terminals 111, 113, 213, 6-158
- Terminals 2U1, 2V1, 2W1, 6-157
- Terminals 5.1, 5.2, 5.3, 6-159
- Terminals 7, 45, 44, 10, 15, 6-157
- Terminals 72, 73.1, 73.2, 74, 6-158
- Terminals AS1, AS2, 6-157
- Terminals L1, L2, 6-156
- Terminals NS1, NS2, 6-154
- Closed-loop Control Module
  - 1-axis for resolvers, 4-91
  - 2-axis for resolvers, 4-91
- Closed-loop control module
  - 2-axis for encoders with sin/cos 1 Vpp, 4-93
  - 2-axis for resolvers, 4-93
- Closed-loop drive control, 4-83
- Commutating reactor(s), 6-174, 6-175
- Configuration
  - Description, 1-28
  - Engineering a drive, 1-31
  - Engineering sheet, 1-36
  - Phases, 1-30
  - Procedure, 1-29
  - Selection, 1-30
- Configurator, 1-29
- Connecting-up, 1-30
- Connection regulations, 9-335
- Control Units, 1-27, 4-81
  - ANA module, 4-112
  - Closed-loop drive control, digital, 4-83
  - HLA module, 4-104
  - Overview, 4-81
  - SIMODRIVE 611 universal HRS, 4-91
- Cooling components, 6-172
- Cooling types, 1-28, 2-57
- Current reduction, 5-128

## D

- DAC assignment, 4-111
- Danger information, viii
- Data volume, 4-91



DC link

- Braking module, 6-191
- Buffering, 8-310
- Capacitor module, 6-183
- Charge/discharge times, 6-190
- Energy balance, 8-310
- External pulsed resistors, 6-194
- Overtoltage limiter module, 6-190, 7-203

DC link voltage, 8-244

Definition

- of the currents, 5-124
- of the load duty cycles, 5-127
- of the power ratings, 5-124

Derating, 6-171

- Inverter clock cycle frequency, 5-129

Dimension drawings, 12-391

Direct position sensing, 3-68

Discharge times, 6-190

Discharge voltage, 6-190

Disposal of devices, 8-266

Drive bus, 2-45, 4-83

Drive line-up, 2-41

**E**

EMC Design Guidelines, 9-335

EMC legislation, 7-230

EMC measures, Grounding, electronics ground, 9-340

Encoder cables, Ordering notes, 3-80

Encoder power supply

- Motor measuring system, 3-72
- SSI encoder, 3-74

EnDat interface, 4-83

Engineering steps, 1-29

Environmentally-friendly disposal of devices, 8-266

Equipment bus, 2-45

ESDS information and instructions, xiv

Example

- Motor changeover, 8-305
- Motor parallel operation, 8-303
- Star-delta operation, 8-298
- Typical circuit diagram, 8-268

Explanation of symbols, viii

External cooling, 2-60

External pulsed resistors, 6-194

**F**

Fan, 6-173

Field-weakening range, 8-302

Folder

- of dimension drawings, 12-391
- of references, B-463

Fundamental principles when engineering a drive

- Braking module, 2-44
- Checking the DC link capacitance, 1-31
- DC link capacitance, 1-31
- Dimensioning, 1-31
- Drive bus, 2-44
- Equipment bus, 2-44
- Feed axes, 1-31
- Length of cable, 2-44
- Power supply rating, 1-31

**H**

Help for the reader, viii

HFD commutating reactor, 6-174

High-voltage test, 9-346

HLA module

- Connecting-up, 4-106
- System components, 4-105, 4-113

Holding brake, 3-63, 4-90, 8-293

Hose package, 6-172

Hotline, vi

**I**

I/R module

- Autotransformer, 7-220
- Technical specifications, 6-165
- Transformer, 7-224

I/R module with HFD reactor, 6-141

Indirect position sensing, 3-68

Induction motor

- Motor changeover, 8-305
- Parallel operation, 8-303
- Series reactor, 8-301
- Star-delta operation, 8-298

Infeed modules, 1-26, 6-141

Installation altitude, 2-46

Installation conditions, 9-341

Installation regulations, 9-335

Interface overview, Bus interfaces, 4-119

Internal cooling, 2-59, 9-341

Internal pulsed resistors, 6-191

Inverter clock cycle frequency, Derating, 5-129

**L**

Leading contact, 7-226

Line choke, 6-175

- Line filter
    - Basic Line Filter, 7-231, 7-235
    - For I/R modules, 7-231
    - For UI modules, 7-231
    - Wideband Line Filter, 7-231
    - Wideband line filter, 7-232
  - Line fuses, 7-215
  - Line infeed, 6-141
  - Line supply connection, 1-26, 4-107, 4-115, 7-201
  - Line system configurations, 7-205
    - IT-line supply, 7-208
    - TN-C line supply, 7-206
    - TT line supply, 7-207
  - Load duty cycle definitions, 5-127
- M**
- Main Spindle Drive
    - Master drive, 8-297
    - Slave drive, 8-297
  - Main switches, 7-226, 8-239
  - Master/slave operation, 8-297
  - Minimum cross-section for PE, 7-209
  - Module
    - ANA module, 4-112
    - Braking module, 1-26
    - Capacitor module, 1-26, 6-183
    - HLA module, 4-104
    - Infeed module, 1-26
    - Monitoring module, 1-26, 6-179
    - Overvoltage limiter module, 7-203
    - Power module, 1-26
    - VP module, 2-48
  - Modules
    - Braking module, 6-191
    - Overvoltage limiter module, 6-190, 7-203
    - Power module, 5-121
  - Monitoring module, 1-26, 6-142, 6-179
    - LED display, 6-181
    - Mode of operation, 6-181
  - Motor
    - Encoder, 3-64
    - Overview, 1-27
    - Protection, 3-63
    - Selection, 2-48, 3-63
    - with holding brake, 3-63
  - Motor changeover, 8-302
  - Motor encoder, 3-64
  - Motor holding brake, 4-90
  - Motor rotor position sensing, 3-68
  - Motor speed sensing, 3-68
  - Mounting and installing the modules, 2-45
- N**
- NCSD Configurator, 1-29
- NE module
    - Block diagram, 6-146
    - Interface overview, 6-147
    - Nominal load duty cycles, 6-169
    - Settings, 6-162
  - Network failure, 8-244
    - Method of operation, 8-307
  - No ground faults, 7-202
  - Nominal load duty cycles
    - FDD, 5-127
    - MSD-IM, 5-127
    - MSD-SRM, 5-127
  - Notes
    - Danger and warning information, viii
    - Hotline, vi
    - regarding the danger of electrostatic discharge, xiv
    - Target group, vi
    - Technical, ix
    - Technical Support, vi
- O**
- One-axis drive control, 4-83
  - Operation when the power fails, 8-307
  - Optional module
    - PROFIBUS-DP, 4-91
    - TERMINALS, 4-91
  - Ordering notes, 1-29
  - Overload protection, 8-306
  - Overview, 1-25
  - Overvoltage limiter module, 6-190, 7-203
  - Overvoltage limiting module, 6-141
- P**
- Parallel operation, 8-302, 8-303
  - PC-Tools, 1-29
  - Personnel – Qualified?, vii
  - Position sensing, 2-49, 3-78
    - Direct, 3-68
    - Indirect, 3-68
  - Position sensing, direct, 3-68
  - Positioning, 3-68
  - Possible arrangements, 2-41
  - Power module, 5-121
    - Internal cooling, 2-52, 5-122
    - Technical specifications, 5-124
  - Power modules, 1-26
  - PROFIBUS DP
    - When can the modules be used?, 4-97
    - Which modules are available?, 4-96
  - PROFIBUS-DP, Which modules are available?, 4-91
  - Proper use, vii
  - Pulse enable, 8-246

Pulse frequency power modules, 5-128  
Pulsed resistor, external, 6-194

## Q

Qualified personnel, vii

## R

Radial fan, 6-172  
Ready for operation, 8-244  
Reference, B-463  
Remote/sense operation, 3-73

## S

Safe standstill, 4-92, 8-252  
Safe start inhibit, 4-92  
Safety information, viii  
Safety Integrated, 8-311  
Selecting components, 1-30  
Series reactor, 8-301  
Set-up operation, 8-244  
Shield connecting plate, 9-338  
Shield contact, 9-338  
Shielding, 9-336  
SIMODRIVE 611 universal HRS, 4-91  
SINUMERIK, 4-83  
SSI encoder, 3-74  
Star-delta operation, 8-298  
Start inhibit, 4-92, 8-252  
Supplementary components, Technical specifications, 6-172  
Support, vi  
SVE (signal amplification electronics), Ordering notes, 3-80  
Switching element, 7-226  
System structure, 1-25

## T

Technical Support, vi  
Terminal overview  
    SIMODRIVE 611 digital, 10-380  
    SIMODRIVE 611 universal HRS, 10-381  
Tightening torque for screws retaining electrical connections, 2-41  
Toolbox, 4-91  
Toothed-wheel encoder, Ordering notes, 3-80  
Transformers, 7-210

Typical circuit diagram  
    with SIMODRIVE 611 digital, 8-295  
    with SIMODRIVE 611 universal HRS, 8-296

## U

UI module, 6-141  
    5 kW, 6-150  
    Commutating reactor(s), 6-175  
    Line choke, 6-175  
    Technical specifications, 6-168  
Using the manual, viii

## V

Variants  
    of the control board, 4-91  
    of the option modules, 4-91  
Voltage limiting module, 8-322  
VP module, 2-48  
VPM, 2-48  
VPM 120, 8-322  
VPM 200, 8-322

## W

Warnings, viii  
Warranty, 1-28

## X

X101, 4-107, 4-115  
X102, 4-107, 4-115  
X111, 4-108, 4-116  
X112, 4-108, 4-116  
X121, 4-109, 4-117  
X122, 4-109, 4-117  
X141, 4-119  
X151, 4-119  
X181, 9-335  
X302, 4-93, 4-94  
X341, 4-119  
X411, 4-88, 4-102, 4-103  
X412, 4-88, 4-102, 4-103  
X421, 4-89  
X422, 4-89  
X431, 4-110, 4-118  
X432, 4-110, 4-118



# SIMODRIVE Documentation Overview

## General Documentation/Catalogs



Catalog NC 60

Automation Systems for  
Machine Tools

Catalog DA 65.4  
SIMODRIVE 611 universal  
and POSMO



Catalog NC Z

Connection  
Technology and  
System Components



Catalog CA 01

Components for  
Automation & Drives

## Manufacturer/Service Documentation

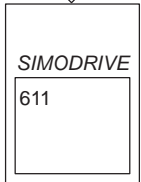

Configuration  
Manual  
Converter

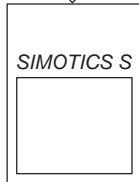

Configuration Manual  
AC Servomotors for Feed  
and Main Spindle Drives  
1FT, 1FK

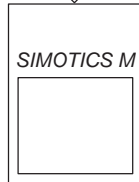

Configuration Manual  
AC Induction Motors  
for Main Spindle Drives  
1PH

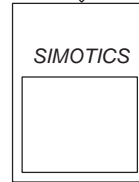

Configuration Manual  
Hollow Shaft Motors for  
Main Spindle Drives  
1PM, 2SP

## Manufacturer/Service Documentation

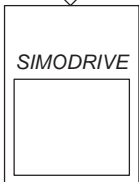

Configuration Manual  
AC Motors  
for Main Spindle Drives  
Synchronous  
Built-In Motors 1FE1

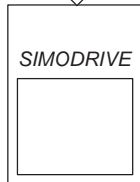

Configuration Manual  
Linear Motors  
1FN

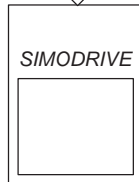

Configuration Manual  
Built-in Torque Motors  
1FW

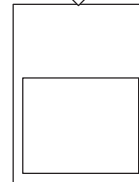

EMC  
Design Guideline

Siemens AG  
Industry Sector  
Drive Technologies  
Motion Control Systems  
Postfach 3180  
91050 ERLANGEN  
GERMANY

Älterations reserved  
© Siemens AG 201&

[www.siemens.com/motioncontrol](http://www.siemens.com/motioncontrol)